



**FRONTIER
ELECTRONICS CO., LTD.**

**SFS2A
THRU
SFS2J**

2A SUPER FAST RECOVERY SURFACE MOUNT RECTIFIER

FEATURES

- LOW PROFILE PACKAGE
- PLASTIC PACKAGE HAS UNDERWRITERS LABORATORY 94V-0
- IDEAL FOR SURFACE MOUNTED APPLICATION
- GLASS PASSIVATED CHIP JUNCTI
- BULIT-IN STRAIN RELIEF DESIGN
- SUPER FAST RECOVERY TIME FOR HIGH EFFICIENT
- HIGH TEMPERATURE SOLDERING : 250°C/10 SECONDS AT TERMINAL

MECHANICAL DATA

- CASE : JEDEC DO-214AA MOLDED PLAS BODY
- TERMINAL : SOLDER PLATED, SOLDERABLE PER MIL-STD-750 METHOD 2026
- POLARITY : COLOR BAND DENOTES CATHODE
- WEIGHT : 0.093 GRAMS

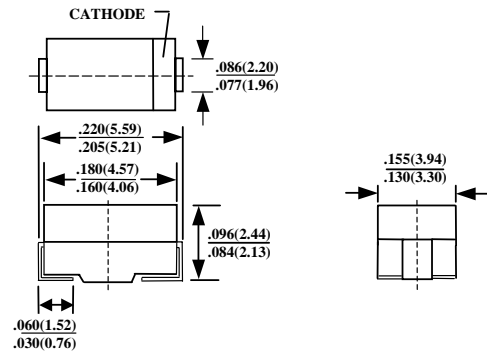

CASE : DO-214AA (SMB)
DIMENSIONS IN INCHES AND (MILLIMETERS)

MAXIMUM RATINGS AND ELECTRICAL CHARACTERISTICS
RATINGS AT 25°C AMBIENT TEMPERATURE UNLESS OTHERWISE SPECIFIED
SINGLE PHASE, HALF WAVE, 60 HZ, RESISTIVE OR INDUCTIVE LOAD.
FOR CAPACITIVE LOAD, DERATE CURRENT BY 20%

RATINGS	SYMBOL	SFS2A	SFS2B	SFS2D	SFS2E	SFS2G	SFS2H	SFS2J	UNITS
MAXIMUM RECURRENT PEAK REVERSE VOLTAGE	V_{RRM}	50	100	200	300	400	500	600	V
MAXIMUM RMS VOLTAGE	V_{RMS}	35	70	140	210	280	350	420	V
MAXIMUM DC BLOCKING VOLTAGE	V_{DC}	50	100	200	300	400	500	600	V
MAXIMUM AVERAGE FORWARD RECTIFIED CURRENT AT $T_J=90^\circ\text{C}$	I_O	2.0							A
PEAK FORWARD SURGE CURRENT, 8.3ms SINGLE HALF SINE-WAVE SUPERIMPOSED ON RATED LOAD	I_{FSM}	50							A
TYPICAL JUNCTION CAPACITANCE (NOTE 1)	C_J	25							PF
TYPICAL THERMAL RESISTANCE (NOTE 2)	$R_{\theta JL}$	20							$^\circ\text{C}/\text{W}$
STORAGE TEMPERATURE RANGE	T_{STG}	- 55 TO + 150							$^\circ\text{C}$
OPERATING TEMPERATURE RANGE	T_{OP}	- 55 TO + 150							$^\circ\text{C}$

ELECTRICAL CHARACTERISTICS ($A_T T_A = 25^\circ\text{C}$ UNLESS OTHERWISE NOTED)

CHARACTERISTICS	SYMBOL	SFS2A	SFS2B	SFS2D	SFS2E	SFS2G	SFS2H	SFS2J	UNITS
MAXIMUM FORWARD VOLTAGE AT I_O DC	V_F	0.95			1.25		1.85		V
MAXIMUM REVERSE CURRENT AT 25°C	I_R	10							μA
MAXIMUM REVERSE CURRENT AT 100°C	I_R	100							μA
MAXIMUM REVERSE RECOVERY TIME (NOTE3)	T_{RR}	35							nS
MARKING		SF2A	SF2B	SF2D	SF2E	SF2G	SF2H	SF2J	

- NOTE :
1. MEASURED AT 1 MHZ AND APPLIED REVERSE VOLTAGE OF 4.0 VOLTS
 2. THERMAL RESISTANCE FROM JUNCTION TO AMBIENT AND JUNCTION TO LEAD P.C.B. MOUNTED ON 0.3x0.3"(8.0x8.0mm) COPPER PAD AREAS
 3. REVERSE RECOVERY TEST CONDITIONS: $I_F=0.5\text{A}$, $I_R=1.0\text{A}$, $I_{RR}=0.25\text{A}$

RATINGS AND CHARACTERISTIC CURVE SFS2A THRU SFS2J

FIG. 1-TEST CIRCUIT DIAGRAM AND REVERSE RECOVERY TIME CHARACTERISTIC

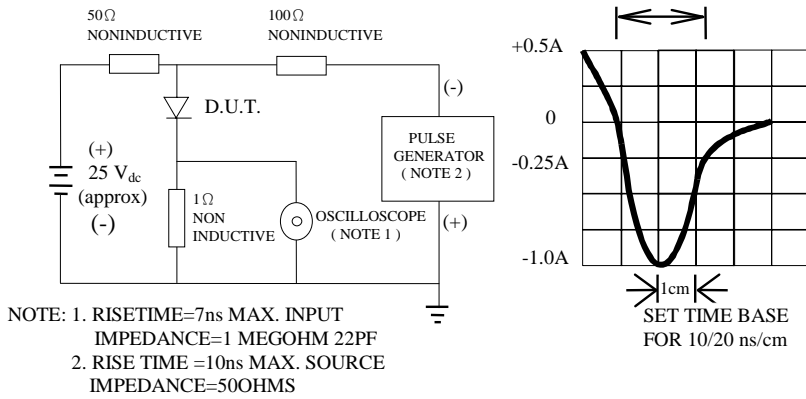

FIG. 2-TYPICAL FORWARD CURRENT DERATING CURVE

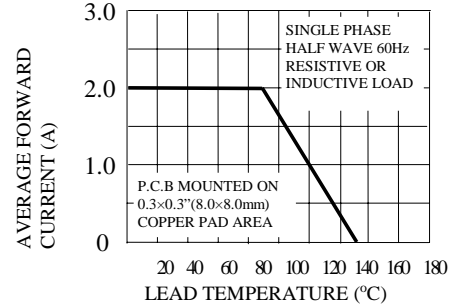

FIG. 3-TYPICAL REVERSE CHARACTERISTICS

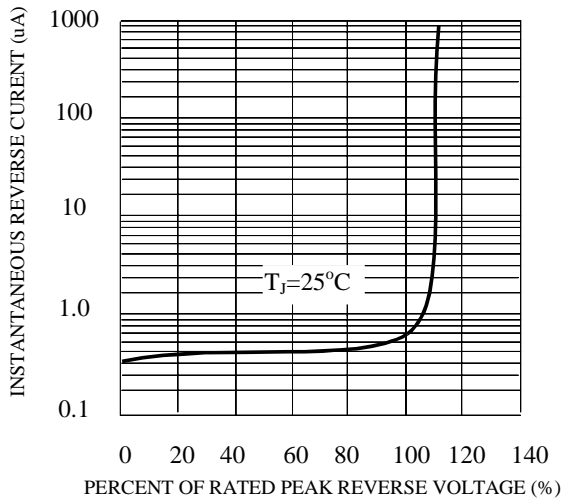

FIG. 4-TYPICAL INSTANTANEOUS FORWARD CHARACTERISTICS

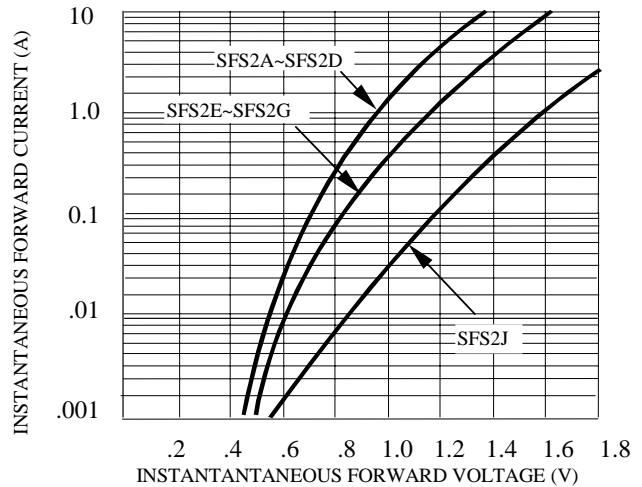

FIG. 5-MAXIMUM NON-REPETITIVE FORWARD SURGE CURRENT

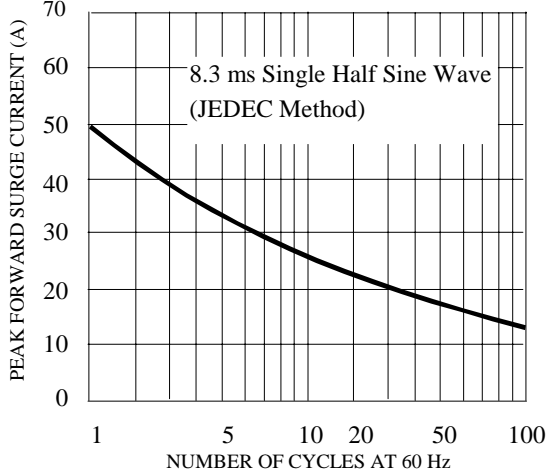

FIG. 6-TYPICAL JUNCTION CAPACITANCE

