

Power transistor (-40V, -2A)

2SB1183 / 2SB1239

●Features

- 1) Darlington connection for high DC current gain.
- 2) Built-in 4kΩ resistor between base and emitter.
- 3) Complements the 2SD1759 / 2SD1861.

●Equivalent circuit

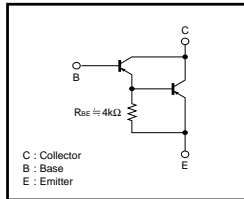

●Absolute maximum ratings (Ta=25°C)

Parameter	Symbol	Limits	Unit
Collector-base voltage	V _{CB0}	-40	V
Collector-emitter voltage	V _{CER}	-40	V
Emitter-base voltage	V _{EBO}	-5	V
Collector current	I _C	-2	A(DC)
		-3	A(Pulse) *1
Collector power dissipation	P _C	1	W
		10	W(Tc=25°C)
Junction temperature	T _J	150	°C
		55~+150	°C
Storage temperature	T _{stg}	-55~+150	°C

*1 Single pulse Pw=10ms
*2 Printed circuit board 1.7 mm thick, collector plating 100mm² or larger.

●External dimensions (Units : mm)

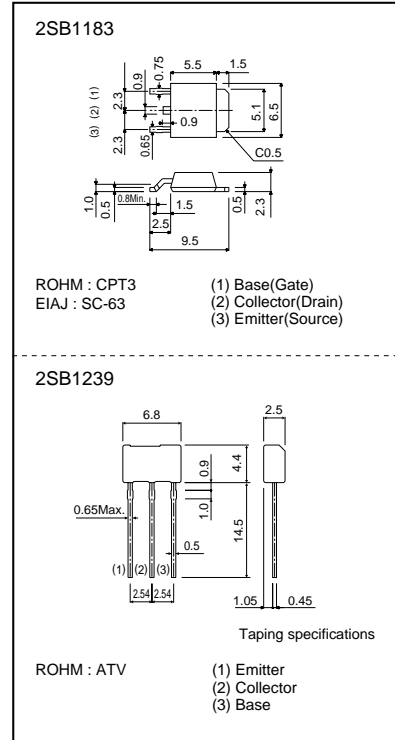

●Packaging specifications and hFE

Type	2SB1183	2SB1239
Package	CPT3	ATV
hFE	1k~200k	1k~
Code	TL	T146
Basic ordering unit (pieces)	2500	2500

●Electrical characteristics (Ta=25°C)

Parameter	Symbol	Min.	Typ.	Max.	Unit	Conditions
Collector-base breakdown voltage	BV _{CB0}	-40	-	-	V	I _C =-50μA
Collector-emitter breakdown voltage	BV _{CER}	-40	-	-	V	I _C =-1mA, R _{BE} =10kΩ
Emitter-base breakdown voltage	BV _{EBO}	-5	-	-	V	I _E =-50μA
Collector cutoff current	I _{CB0}	-	-	-1	μA	V _{CB} =-24V
Emitter cutoff current	I _{EBO}	-	-	-1	μA	V _{EB} =-4V
Collector-emitter saturation voltage	V _{CE(sat)}	-	-	-1.5	V	I _C /I _B =-0.6A/-1.2mA
DC current transfer ratio	h _{FE}	1000	-	20000	-	V _{CE} /I _C =-2V/-0.5A
		1000	-	-	-	
Output capacitance	C _{ob}	-	11	-	pF	V _{CB} =-10V, I _E =0A, f=1MHz