

■ General Description

The AME431B series ICs are 3-terminal adjustable shunt regulator with guaranteed temperature stability over a full operation range. These ICs feature sharp turn-on characteristics, low temperature coefficient and low output impedance, which make them ideal substitutes for Zener diodes in applications such as switching power supply, charger and other adjustable regulators.

The reference is set to 2.5V for AME431Bxxxxx25. The output voltage can be set to 2.5V to 36V for $V_{REF}=2.5V$ part type with two external resistors.

The AME431B precision reference is offered in two reference tolerance: 0.5% and 1.0%

The 5 main packages have low thermal impedance which allows operation over a wide range of $-40^{\circ}C$ to $+125^{\circ}C$.

■ Functional Block Diagram

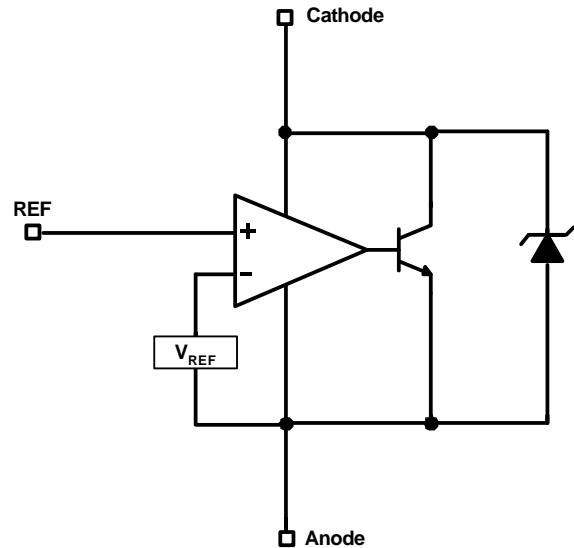

■ Features

- High Stability under Capacitive Load
- Low Temperature Deviation: 4.5mV Typical
- Low Equivalent Full-Range Temperature Coefficient with 20PPM/ $^{\circ}C$ Typical
- Low Dynamic Output Resistance: 0.2Ω Typical
- Sink Current Capacity from 1mA to 100mA
- Low Output Noise
- Available in 7 Packages: TO-92-3, SOT-23, SOT-89, SOP-8, SOT-25, TSOT-23 and TSOT-25
- All AME's Lead Free Products Meet RoHS Standards

■ Applications

- Adjustable Power Supplies
- Linear Regulators
- Battery Operated Computer
- Portable Electronics
- Instrumentation
- Switching Power Supply
- Mother Board
- LCD Monitor
- Note Book Computer

■ Typical Applications

Shunt Regulator

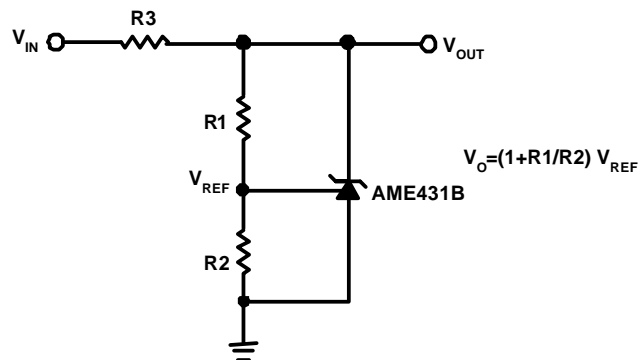

High Current Shunt Regulator

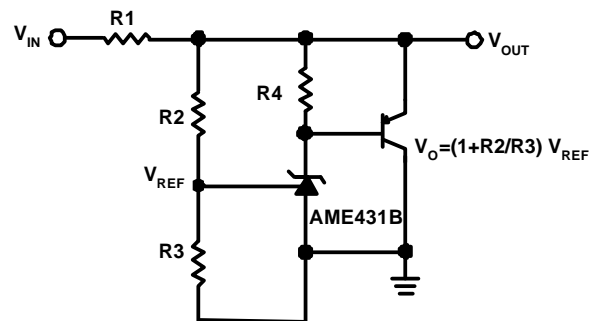

Current Source or Current Limit

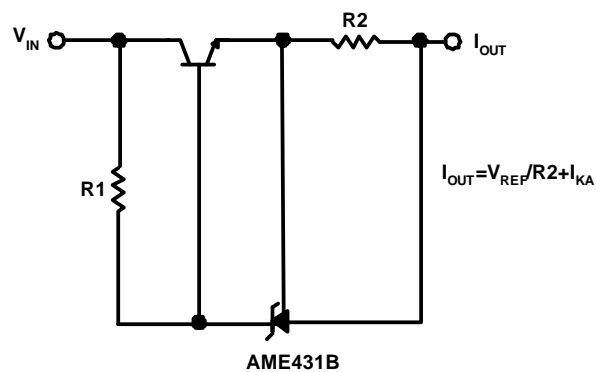

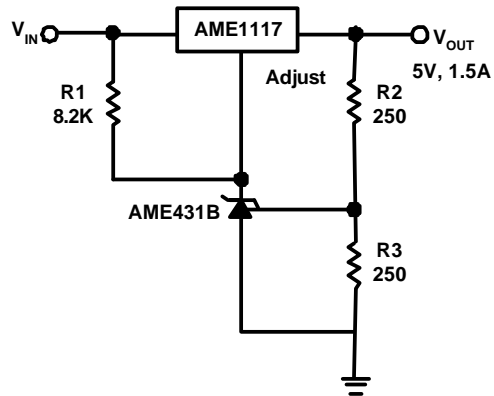
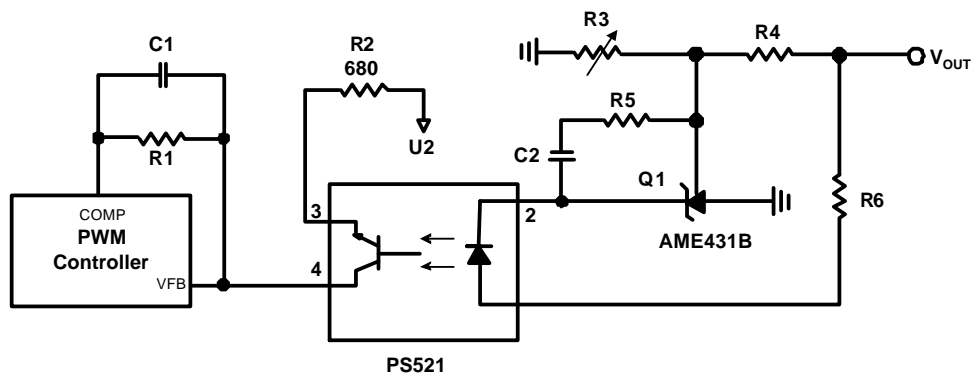
■ Typical Applications (contd.)
Precision 5V 1.5A Regulator

Precision 5V 1.5A Regulator

AME431B-2.5V

■ Pin Configuration

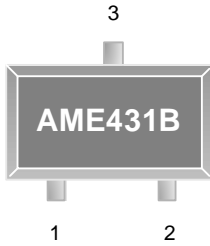
**SOT-23/TSOT-23
Top View**



AME431BAJETXXXX

1. Cathode
2. REF
3. Anode

*** Die Attach:
Conductive Epoxy**

**SOT-23/TSOT-23
Top View**

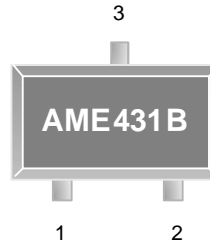

AME431BBJETXXXX

1. REF
2. Cathode
3. Anode

*** Die Attach:
Conductive Epoxy**

**SOT-89
Front View**

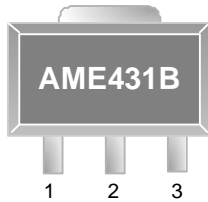

AME431BAJFTXXXX

1. REF
2. Anode
3. Cathode

*** Die Attach:
Conductive Epoxy**

**SOT-25/TSOT-25
Top View**

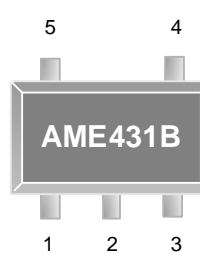

AME431BAJEVXXXX

1. NC
2. NC
3. Cathode
4. REF
5. Anode

*** Die Attach:
Non-Conductive Epoxy**

**SOP-8
Top View**

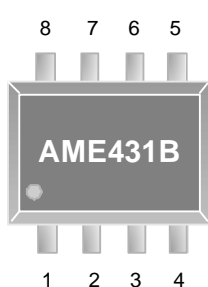

AME431BAJHAXXXX

1. Cathode
2. Anode
3. Anode
4. NC
5. NC
6. Anode
7. Anode
8. REF

*** Die Attach:
Conductive Epoxy**

**TO-92-3
Top View**

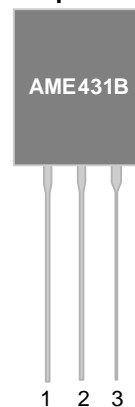

AME431BAJATXXXX

1. REF
2. Anode
3. Cathode

*** Die Attach:
Conductive Epoxy**



Adjustable Precision Shunt Regulator

AME431B-2.5V

Ordering Information

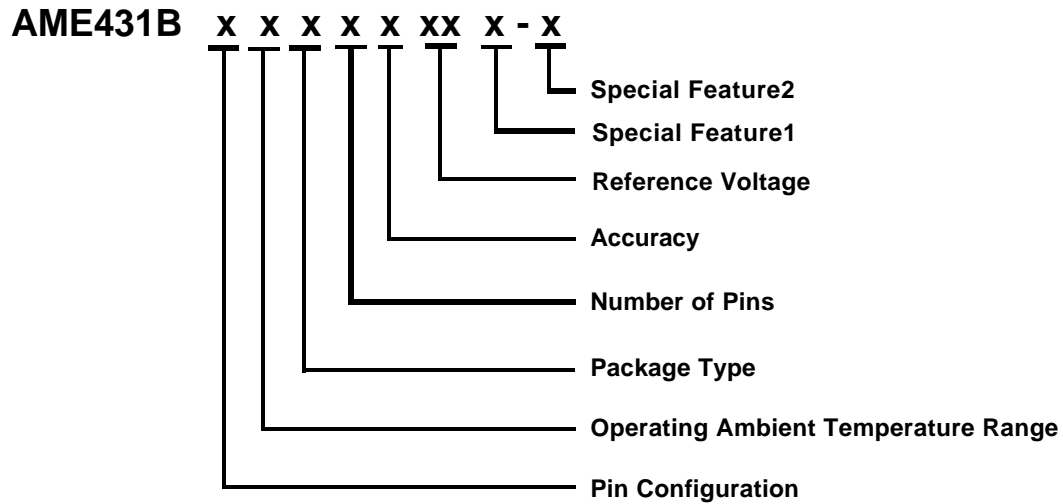

Pin Configuration	Operating Ambient Temperature Range	Package Type	Number of Pins	Accuracy	Reference Voltage	Special Feature1	Special Feature2 (For TO-92 Package Only)	
							Package	Lead Pitch
A 1. Cathode <small>(SOT-23)</small> 2. REF <small>(TSOT-23)</small> 3. Anode B 1. REF <small>(SOT-23)</small> 2. Cathode <small>(TSOT-23)</small> 3. Anode A 1. REF <small>(SOT-89)</small> 2. Anode 3. Cathode A 1. REF <small>(TO-92-3)</small> 2. Anode 3. Cathode A 1. Cathode <small>(SOP-8)</small> 2. Anode 3. Anode 4. NC 5. NC 6. Anode 7. Anode 8. REF A 1. NC <small>(SOT-25)</small> 2. NC <small>(TSOT-25)</small> 3. Cathode 4. REF 5. Anode	J: -40°C to +125°C	A: TO-92 E: SOT-2X F: SOT-89 H: SOP	A: 8 T: 3 V: 5	A: 0.5% B: 1.0%	25: 2.5V	Y: Lead free & Low profile Z: Lead free	N/A: 1:	Taping 5.08mm Bulk 2.54mm

AME431B-2.5V
■ Ordering Information

Part Number	Marking*	Reference Voltage	Accuracy	Package	Operating Ambient Temperature Range
AME431BAJETA25Z	BAFww	2.5V	0.5%	SOT-23	- 40°C to +125°C
AME431BAJETA25Y	BAFww	2.5V	0.5%	TSOT-23	- 40°C to +125°C
AME431BBJETA25Z	BAGww	2.5V	0.5%	SOT-23	- 40°C to +125°C
AME431BBJETA25Y	BAGww	2.5V	0.5%	TSOT-23	- 40°C to +125°C
AME431BAJETB25Z	AZAww	2.5V	1.0%	SOT-23	- 40°C to +125°C
AME431BAJETB25Y	AZAww	2.5V	1.0%	TSOT-23	- 40°C to +125°C
AME431BBJETB25Z	AZBww	2.5V	1.0%	SOT-23	- 40°C to +125°C
AME431BBJETB25Y	AZBww	2.5V	1.0%	TSOT-23	- 40°C to +125°C
AME431BAJFTA25Z	A431B BKXww	2.5V	0.5%	SOT-89	- 40°C to +125°C
AME431BAJFTB25Z	A431B BJBww	2.5V	1.0%	SOT-89	- 40°C to +125°C
AME431BAJHAB25Z	431B BJCww	2.5V	1.0%	SOP-8	- 40°C to +125°C
AME431BAJATB25Z	AME25 431B AJATB yyww	2.5V	1.0%	TO-92-3	- 40°C to +125°C
AME431BAJATB25Z-1	AME25 431B AJATB yyww	2.5V	1.0%	TO-92-3	- 40°C to +125°C
AME431BAJATA25Z	AME25 431B AJATA yyww	2.5V	0.5%	TO-92-3	- 40°C to +125°C
AME431BAJATA25Z-1	AME25 431B AJATA yyww	2.5V	0.5%	TO-92-3	- 40°C to +125°C

Note: yyww & ww represents the date code and pls refer to Date Code Rule on Package Dimension.

* A line on top of the first letter represents lead free plating such as BAFww.

Please consult AME sales office or authorized Rep./Distributor for output voltage and package type availability.

AME431B-2.5V**■ Absolute Maximum Ratings**

Parameter	Maximum	Unit
Cathode Current	150	mA
Cathode Voltage	40	V

Caution: Stress above the listed absolute maximum rating may cause permanent damage to the device

■ Recommended Operating Conditions

Parameter	Rating		Unit
Supply Current	1 to 100		mA
Operation Voltage Range	2.5 to 36		V
Ambient Temperature Range	T_A	-40 to +125	°C
Junction Temperature Range	T_J	-40 to +125	°C
Storage Temperature Range	T_{STG}	-65 to +150	°C

■ Thermal Information

Parameter	Package	Die Attach	Symbol	Maximum	Unit
Thermal Resistance (Junction to Case)	SOT-23** TSOT-23	Conductive Epoxy	θ_{JC}	81	°C / W
	SOT-89*			40	
	TO-92-3**			80	
	SOP-8**			60	
	SOT-25** TSOT-25	Non-Conductive Epoxy		140	
Thermal Resistance (Junction to Ambient)	SOT-23 TSOT-23	Conductive Epoxy	θ_{JA}	260	°C / W
	SOT-89			180	
	TO-92-3			150	
	SOP-8			150	
	SOT-25 TSOT-25	Non-Conductive Epoxy		280	
Internal Power Dissipation	SOT-23 TSOT-23	Conductive Epoxy	P_D	400	mW
	SOT-89			550	
	TO-92-3			625	
	SOP-8			810	
	SOT-25 TSOT-25	Non-Conductive Epoxy		400	
Solder Iron (10 Sec)***				350	°C

* Measure θ_{JC} on backside center of tab.

** Measure θ_{JC} on center of molding compound if IC has no tab.

*** MIL-STD-202G 210F

AME431B-2.5V

■ Electrical Specifications (AME431Bxxxxx25)

$T_A = 25^\circ\text{C}$, $I_{REF} = 10\text{mA}$ unless otherwise specified

Parameter	Test Circuit	Symbol	Test Condition	Min	Typ	Max	Units	
Reference Voltage	0.5%	1	$V_{KA} = V_{REF}$, $I_{KA} = 10\text{mA}$	2.4875	2.50	2.5125	V	
	1.0%			2.4750	2.50	2.5250		
Deviation of Reference Voltage Over Temperature	1	ΔV_{REF}	$V_{KA} = V_{REF}$ $I_{KA} = 10\text{mA}$	0°C to 70°C	-	4.5	8	mV
				-40°C to +125°C	-	4.5	18	
Ratio of Change in Reference Voltage to the Change in Cathode Voltage	2	$\frac{\Delta V_{REF}}{\Delta V_{KA}}$	$I_{KA} = 10\text{mA}$	$\Delta V_{KA} = 10\text{V to } V_{REF}$	-	-1.0	-2.7	mV/V
				$\Delta V_{KA} = 36\text{V to } 10\text{V}$	-	-0.5	-2.0	
Reference Current	2	I_{REF}	$I_{KA} = 10\text{mA}$ $R1 = 10\text{K}\Omega$, $R2 = \infty$	-	0.7	4.0	μA	
Deviation of Reference Current Over Full Temperature Range	2	ΔI_{REF}	$R1 = 10\text{K}\Omega$, $R2 = \infty$ $I_{KA} = 10\text{mA}$ $T_A = -40^\circ\text{C to } +125^\circ\text{C}$	-	0.4	1.2	μA	
Minimum Cathode Current for Regulation	1	I_{KA} (MIN)	$V_{KA} = V_{REF}$	-	0.4	1.0	mA	
Off-State Cathode Current	3	I_{KA} (OFF)	$V_{KA} = 36\text{V}$, $V_{REF} = 0\text{V}$	-	0.05	1.0	μA	
Dynamic Impedance	1	Z_{KA}	$V_{KA} = V_{REF}$, $I_{KA} = 1$ to 100mA $F \leq 1\text{KHz}$	-	0.15	0.5	Ω	

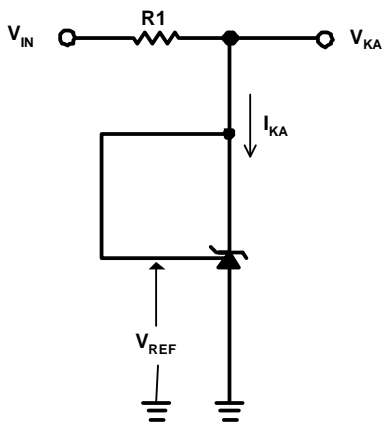

Figure1.
Test Circuit for $V_{KA} = V_{REF}$

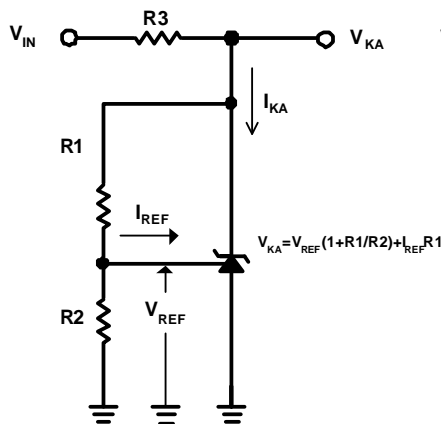

Figure2.
Test Circuit for $V_{KA} > V_{REF}$

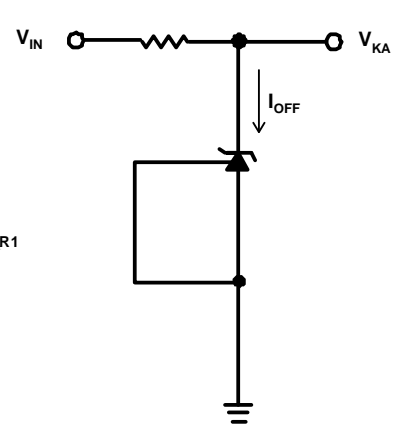
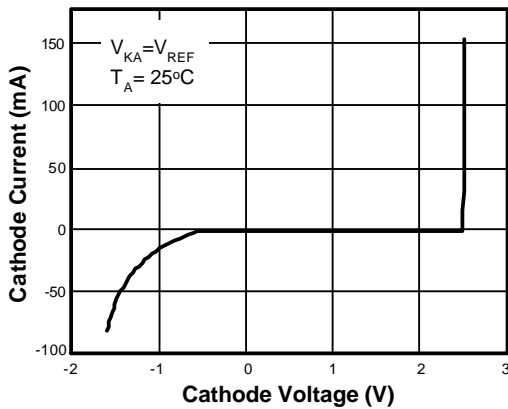
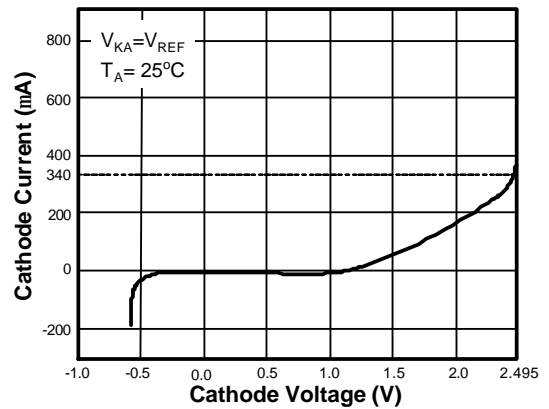
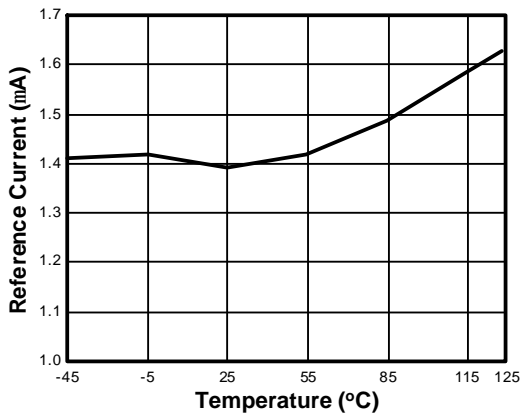
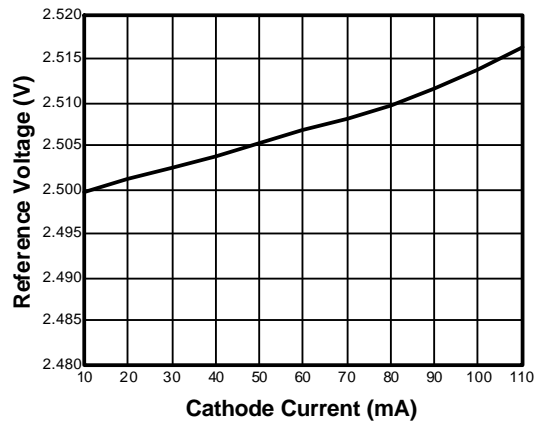
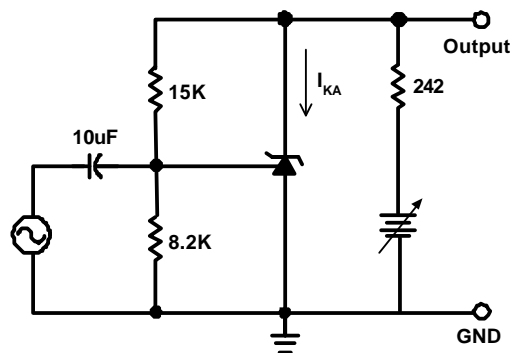
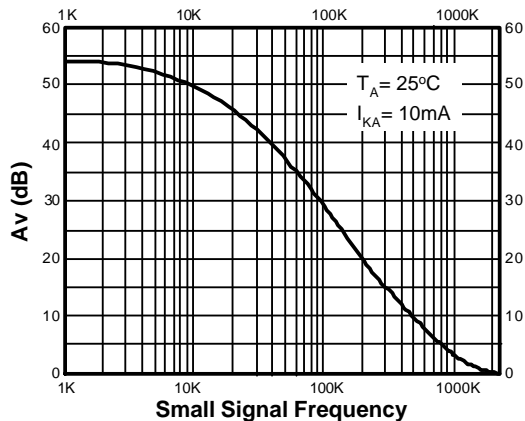
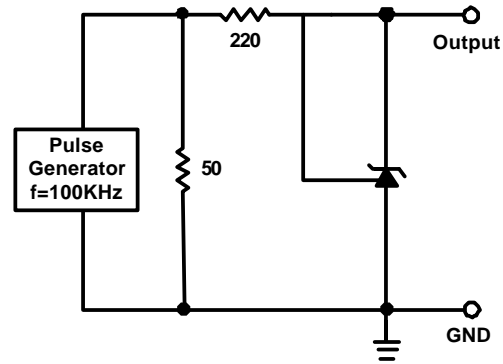
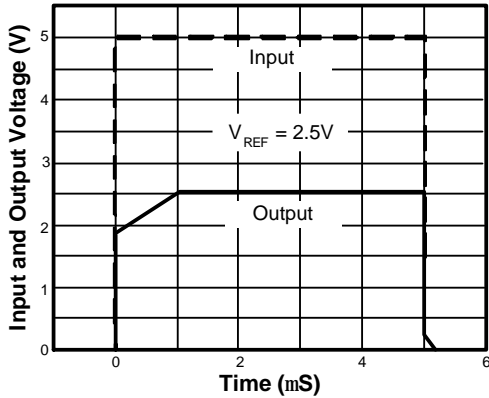
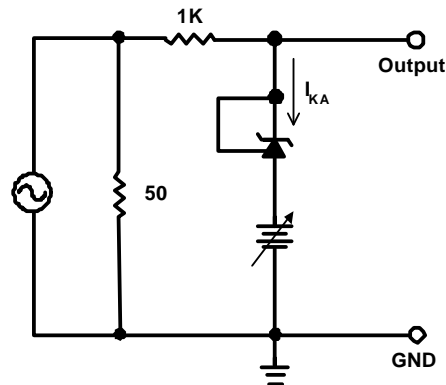
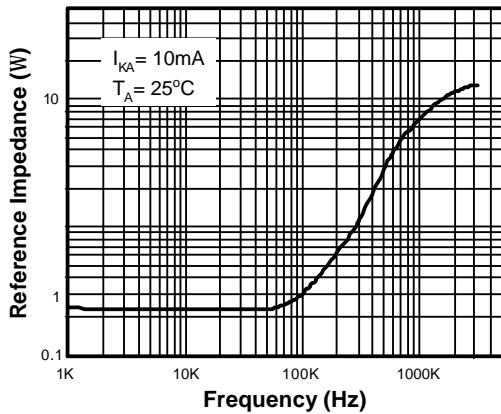
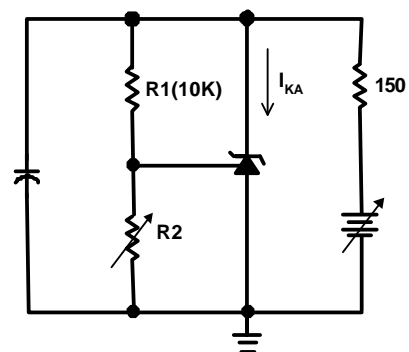
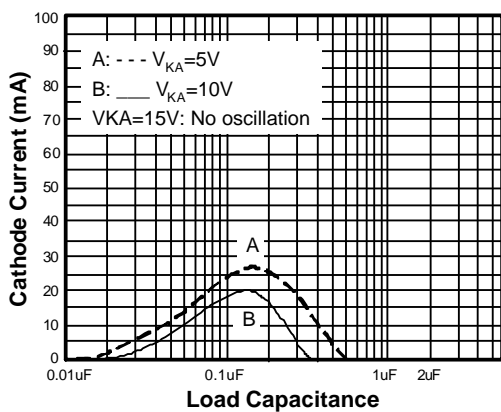
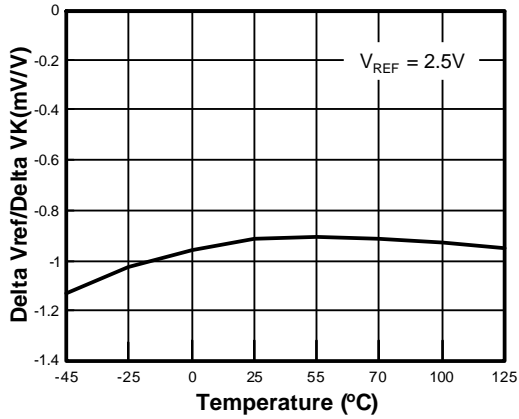
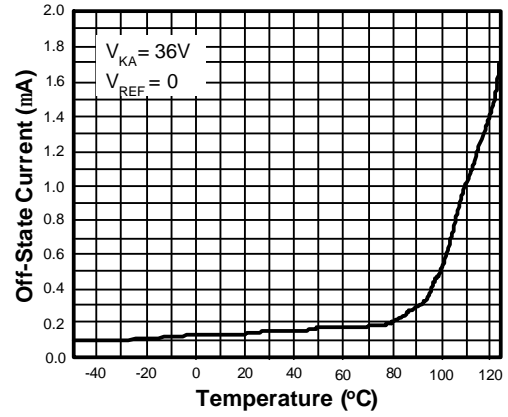
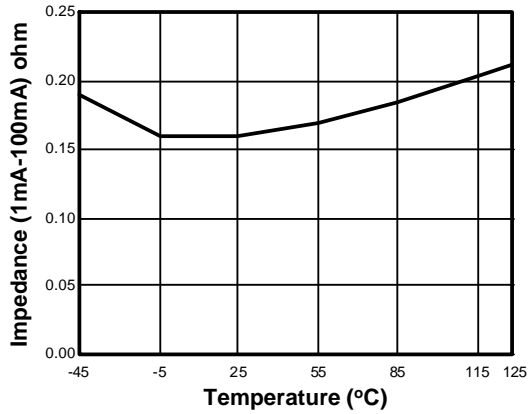
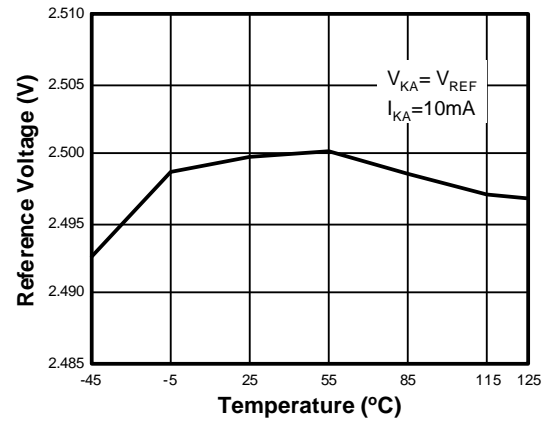

Figure3.
Test Circuit for I_{OFF}

Cathode Current vs. Cathode Voltage

Current vs. Cathode Voltage

Reference Current vs. Temperature

Reference Voltage vs. Cathode Current

Small Signal Voltage Gain vs. Frequency

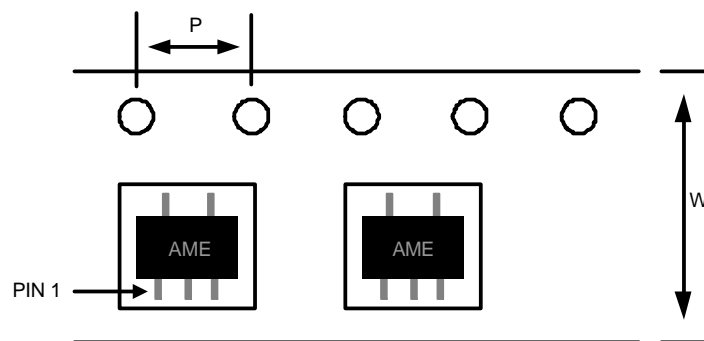
Small Signal Voltage Gain vs. Frequency

Reference Impedance vs. Frequency

Stability Boundary Conditions vs. Load Capacitance

Delta Reference Voltage vs. Temperature

Off-State Current vs. Temperature

Impedance vs. Temperature

Reference Voltage vs. Temperature

AME431B-2.5V
■ Date Code Rule

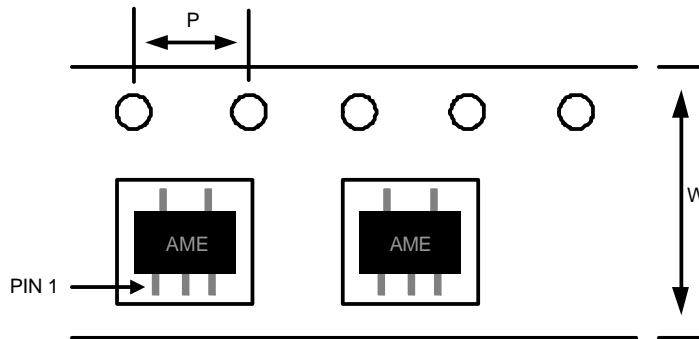
Marking			Date Code		Year
A	A	A	W	W	xxx0
A	A	A	W	<u>W</u>	xxx1
A	A	A	<u>W</u>	W	xxx2
A	A	A	<u>W</u>	<u>W</u>	xxx3
A	A	<u>A</u>	W	W	xxx4
A	A	<u>A</u>	W	<u>W</u>	xxx5
A	A	<u>A</u>	<u>W</u>	W	xxx6
A	A	<u>A</u>	<u>W</u>	<u>W</u>	xxx7
A	<u>A</u>	A	W	W	xxx8
A	<u>A</u>	A	W	<u>W</u>	xxx9

■ Tape and Reel Dimension
SOT-25

Carrier Tape, Number of Components Per Reel and Reel Size

Package	Carrier Width (W)	Pitch (P)	Part Per Full Reel	Reel Size
SOT-25	8.0±0.1 mm	4.0±0.1 mm	3000pcs	180±1 mm

AME431B-2.5V
■ Tape and Reel Dimension
TSOT-25

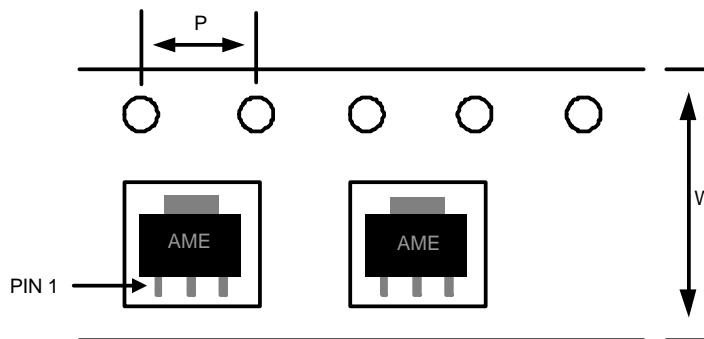
Carrier Tape, Number of Components Per Reel and Reel Size

Package	Carrier Width (W)	Pitch (P)	Part Per Full Reel	Reel Size
TSOT-25	8.0±0.1 mm	4.0±0.1 mm	3000pcs	180±1 mm

SOT-89

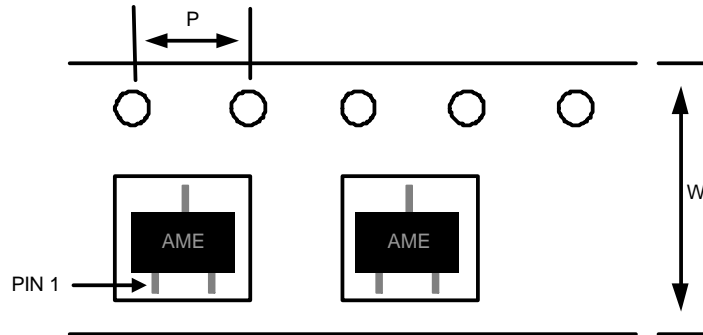
Carrier Tape, Number of Components Per Reel and Reel Size

Package	Carrier Width (W)	Pitch (P)	Part Per Full Reel	Reel Size
SOT-89	12.0±0.1 mm	4.0±0.1 mm	1000pcs	180±1 mm

AME431B-2.5V
■ Tape and Reel Dimension
SOT-23

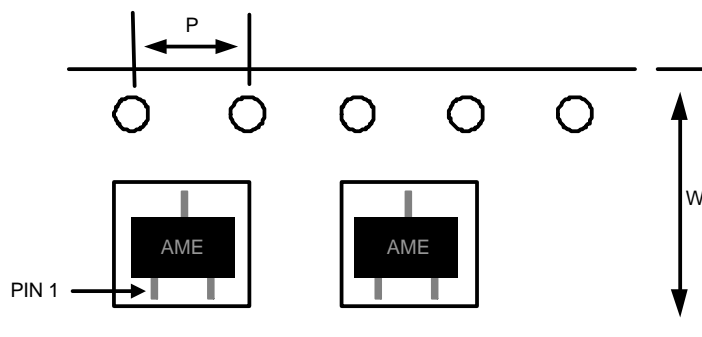
Carrier Tape, Number of Components Per Reel and Reel Size

Package	Carrier Width (W)	Pitch (P)	Part Per Full Reel	Reel Size
SOT-23	8.0±0.1 mm	4.0±0.1 mm	3000pcs	180±1 mm

TSOT-23

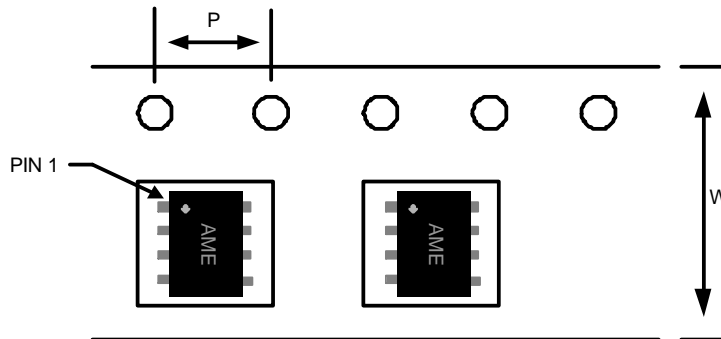
Carrier Tape, Number of Components Per Reel and Reel Size

Package	Carrier Width (W)	Pitch (P)	Part Per Full Reel	Reel Size
TSOT-23	8.0±0.1 mm	4.0±0.1 mm	3000pcs	180±1 mm

AME431B-2.5V
■ Tape and Reel Dimension
SOP-8

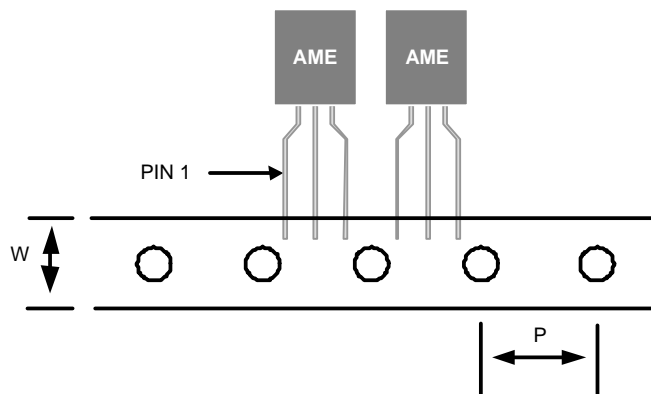
Carrier Tape, Number of Components Per Reel and Reel Size

Package	Carrier Width (W)	Pitch (P)	Part Per Full Reel	Reel Size
SOP-8	12.0±0.1 mm	4.0±0.1 mm	2500pcs	330±1 mm

TO-92-3

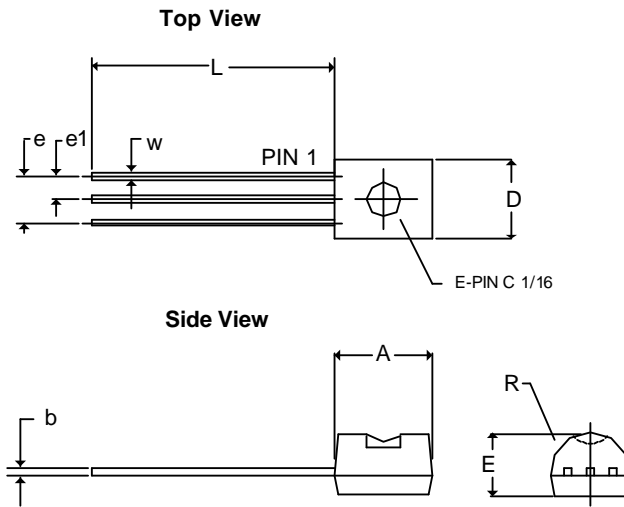
Carrier Tape, Number of Components Per Reel and Reel Size

Package	Carrier Width (W)	Pitch (P)	Part Per Full Reel	Reel Size
TO-92-3	18.0 ^{+1.0} _{-0.5} mm	12.7±0.2 mm	2000pcs	N/A

■ Package Dimension
TO-92-3 (bulk pack)

SYMBOLS	MILLIMETERS		INCHES	
	MIN	MAX	MIN	MAX
A	2.80	4.95	0.1102	0.1949
b	0.40REF		0.0157REF	
E	3.94REF		0.1551REF	
e	2.54REF		0.1000REF	
e1	1.27REF		0.0500REF	
L	12.70	15.49	0.5000	0.6098
R	2.29		0.0902	
W	0.35	0.76	0.0138	0.0299
D	3.80	4.95	0.1496	0.1949

Notes:

1. Package outline exclusive of any mold flashes dimension.
2. Package outline exclusive of burr dimension.
3. Lead pitch=2.54mm is bulk pack.
4. Lead pitch=5.08mm is tape pack.

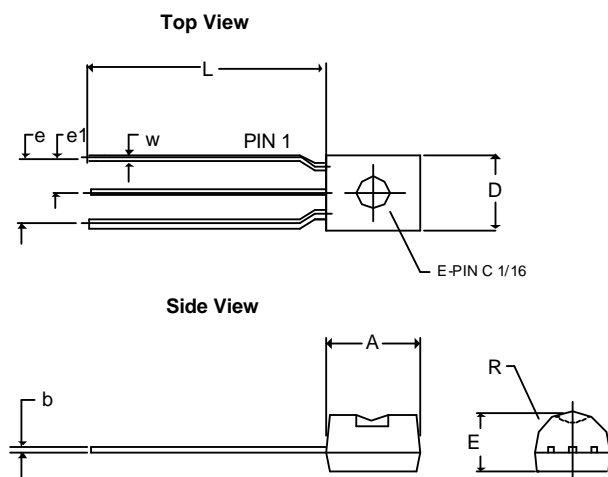
TO-92-3 (tape pack)

SYMBOLS	MILLIMETERS		INCHES	
	MIN	MAX	MIN	MAX
A	2.80	4.95	0.1102	0.1949
b	0.40REF		0.0157REF	
E	2.40	3.94	0.0945	0.1551
e	5.08REF		0.2REF	
e1	2.54REF		0.1REF	
L	12.70	15.49	0.5000	0.6098
R	2.00		0.0787	
W	0.35	0.76	0.0138	0.0299
D	3.80	4.95	0.1496	0.1949

Notes:

1. Package outline exclusive of any mold flashes.
2. Package outline exclusive of burr dimension.
3. Lead pitch=2.54mm is bulk pack.
4. Lead pitch=5.08mm is tape pack.

AME431B-2.5V

■ Package Dimension

SOT-23

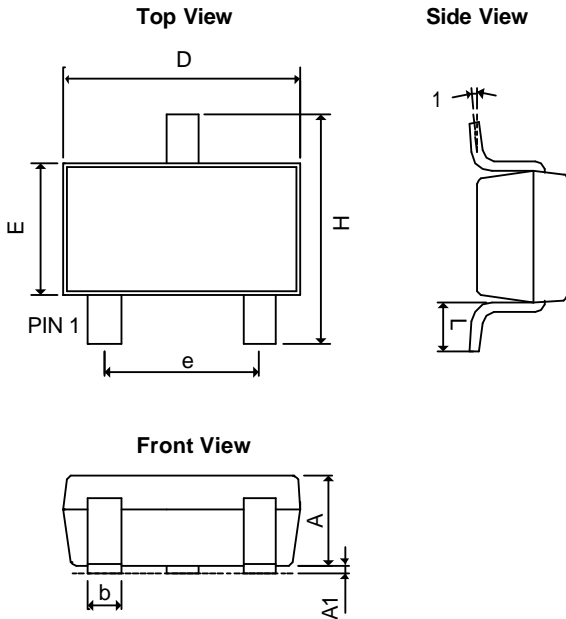

SYMBOLS	MILLIMETERS		INCHES	
	MIN	MAX	MIN	MAX
A	1.00	1.40	0.0394	0.0551
A ₁	0.00	0.15	0.0000	0.0059
b	0.35	0.50	0.0138	0.0197
D	2.70	3.10	0.1063	0.1220
E	1.40	1.80	0.0551	0.0709
e	1.90 BSC		0.0748 BSC	
H	2.40	3.00	0.09449	0.11811
L	0.35BSC		0.0138BSC	
q1	0°	10°	0°	10°

TSOT-23

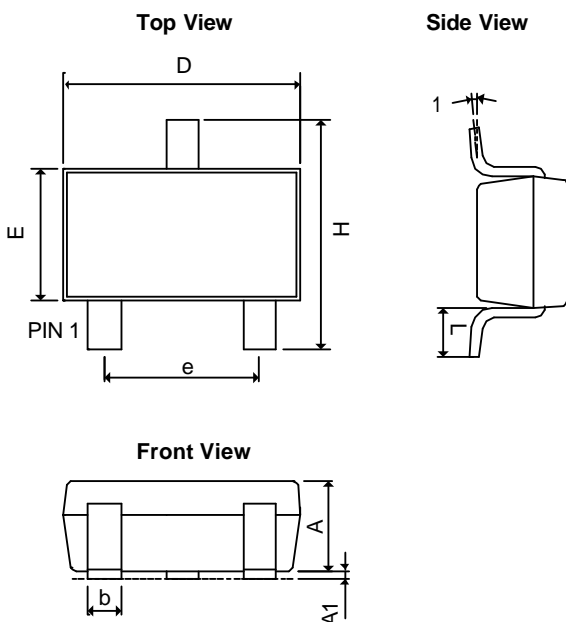

SYMBOLS	MILLIMETERS		INCHES	
	MIN	MAX	MIN	MAX
A+A ₁	0.80	1.30	0.0315	0.0512
b	0.35	0.50	0.0138	0.0197
D	2.70	3.10	0.1063	0.1220
E	1.20	1.80	0.0472	0.0709
e	1.90 BSC		0.0748 BSC	
H	2.40	3.00	0.09449	0.11811
L	0.35BSC		0.0138BSC	
q1	0°	10°	0°	10°

AME431B-2.5V

■ Package Dimension

SOT-89

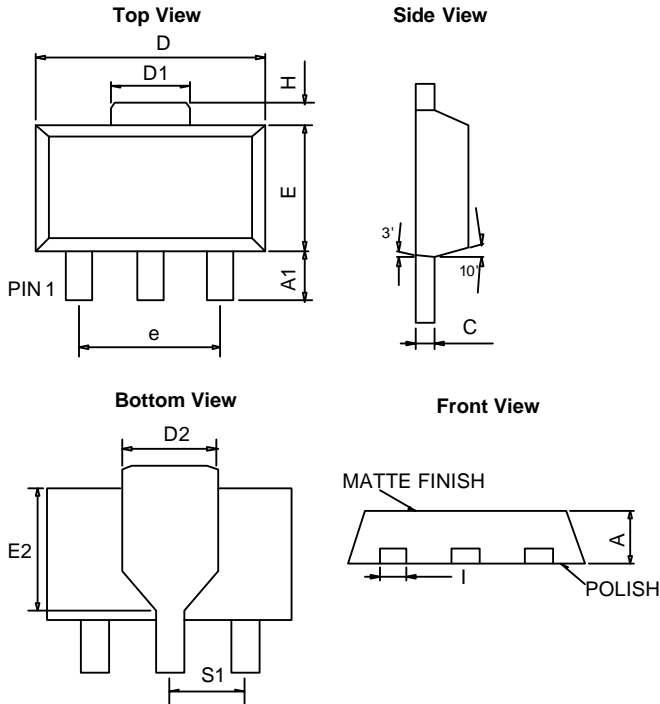

SYMBOLS	MILLIMETERS		INCHES	
	MIN	MAX	MIN	MAX
A	1.39	1.60	0.05472	0.06299
A₁	0.8 REF		0.03150 REF	
C	0.35	0.44	0.01378	0.01732
D	4.39	4.60	0.17283	0.18110
D₁	1.35	1.83	0.05315	0.07205
E	2.28	2.60	0.08976	0.10236
I	0.36	0.56	0.01417	0.02204
e	3.00 REF		0.11811 REF	
H	0.70 REF		0.02756 REF	
S₁	1.50 REF		0.05906 REF	
E₂	2.05	2.60	0.08071	0.10236
D₂	1.50	1.85	0.05905	0.07283

AME431B-2.5V

■ Package Dimension

SOP-8

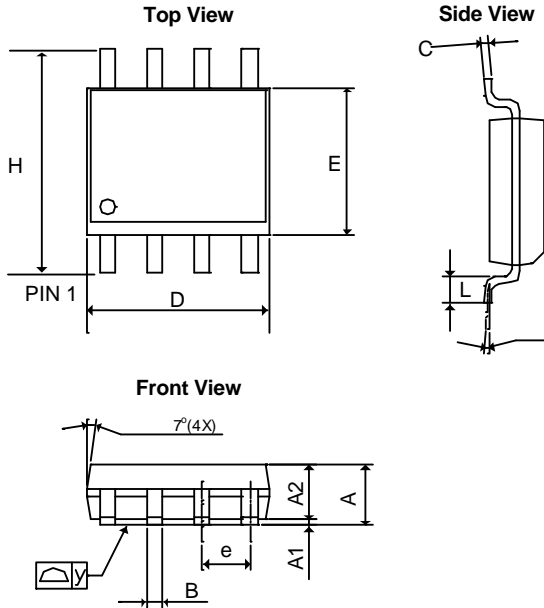

SYMBOLS	MILLIMETERS		INCHES	
	MIN	MAX	MIN	MAX
A	1.35	1.75	0.05315	0.0689
A ₁	0.10	0.30	0.00394	0.01181
A ₂	1.473 REF		0.05799 REF	
B	0.33	0.51	0.01299	0.02008
C	0.19	0.25	0.00748	0.00984
D	4.80	5.33	0.18898	0.20984
E	3.80	4.00	0.14961	0.15748
e	1.27 BSC		0.05000 BSC	
L	0.40	1.27	0.01575	0.05000
H	5.80	6.30	0.22835	0.24803
y	-	0.10	-	0.00394
q	0°	8°	0°	8°

SOT-25

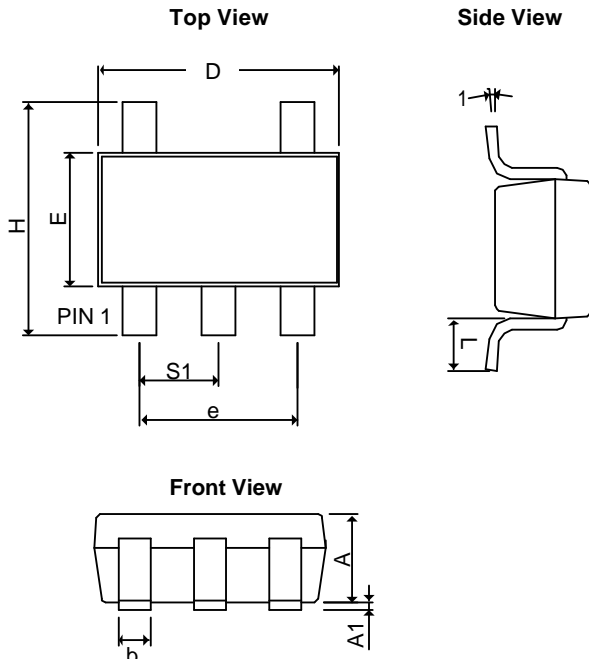

SYMBOLS	MILLIMETERS		INCHES	
	MIN	MAX	MIN	MAX
A	1.20REF		0.0472REF	
A ₁	0.00	0.15	0.0000	0.0059
b	0.30	0.55	0.0118	0.0217
D	2.70	3.10	0.1063	0.1220
E	1.40	1.80	0.0551	0.0709
e	1.90 BSC		0.07480 BSC	
H	2.60	3.00	0.10236	0.11811
L	0.37BSC		0.0146BSC	
q1	0°	10°	0°	10°
S ₁	0.95BSC		0.0374BSC	

AME431B-2.5V

■ Package Dimension

TSOT-25

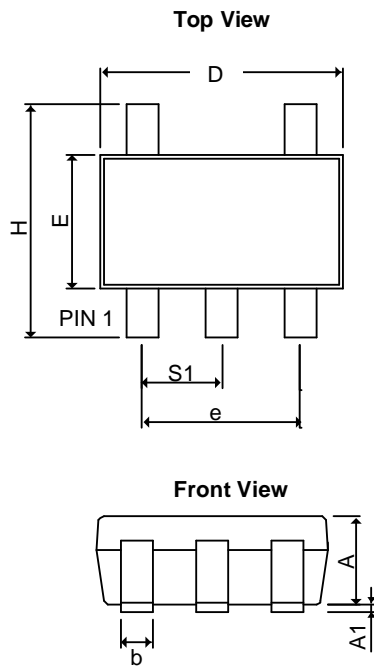

SYMBOLS	MILLIMETERS		INCHES	
	MIN	MAX	MIN	MAX
A+A ₁	0.90	1.25	0.0354	0.0492
b	0.30	0.50	0.0118	0.0197
D	2.70	3.10	0.1063	0.1220
E	1.40	1.80	0.0551	0.0709
e	1.90 BSC		0.07480 BSC	
H	2.40	3.00	0.09449	0.11811
L	0.35BSC		0.0138BSC	
q1	0°	10°	0°	10°
S ₁	0.95BSC		0.0374BSC	



www.ame.com.tw
E-Mail: sales@ame.com.tw

Life Support Policy:

These products of AME, Inc. are not authorized for use as critical components in life-support devices or systems, without the express written approval of the president of AME, Inc.

AME, Inc. reserves the right to make changes in the circuitry and specifications of its devices and advises its customers to obtain the latest version of relevant information.

© AME, Inc. , November 2008
Document: ORT-DS431B-B.04

Corporate Headquarter
AME, Inc.

2F, 302 Rui-Guang Road, Nei-Hu District
Taipei 114, Taiwan.
Tel: 886 2 2627-8687
Fax: 886 2 2659-2989