LCD Driver IC with Key Input Function

PT6583

Description

PT6583 is an LCD Driver IC utilizing CMOS Technology. It can drive up to 171 segments and control up to a maximum of 4 General Purpose Output Ports. Key Scan Circuit, Built-in Voltage Detection Type (VDET) Reset Circuit, Sleep Mode, 1/3 Duty - 1/2 Bias and 1/3 Duty - 1/3 Bias Drive Techniques, Forced All Segments OFF function are supported and provided into a single chip having the highest performance and reliability. Display data are directly displayed without the need of a decoder, thereby providing a high level of generality. Pin assignments and application circuit are optimized for easy PCB layout and cost saving advantages.

Features

- CMOS Technology
- Up to 30 Key Inputs
- 1/3 Duty, 1/2 Bias and 1/3 Duty , 1/3 Bias Drive Techniques controlled via a Serial Data
- Sleep Mode
- Forced All Segments OFF Function
- Up to 171 Segment Driver Outputs (3 Common & 57 Segment Drivers)
- Up to 4 General Purpose Ports
- Built-in Voltage Detection Type Reset Circuit
- RC Oscillation Circuit

Applications

- Cellular Phone
- Data Bank, Organizer
- Electronic Dictionary / Translator
- P.D.A.
- P.O.S.
- Information Appliance
- Caller ID, Pager
- Electronic Equipment with LCD Display

LCD Driver IC with Key Input Function

PT6583

Pin Configuration

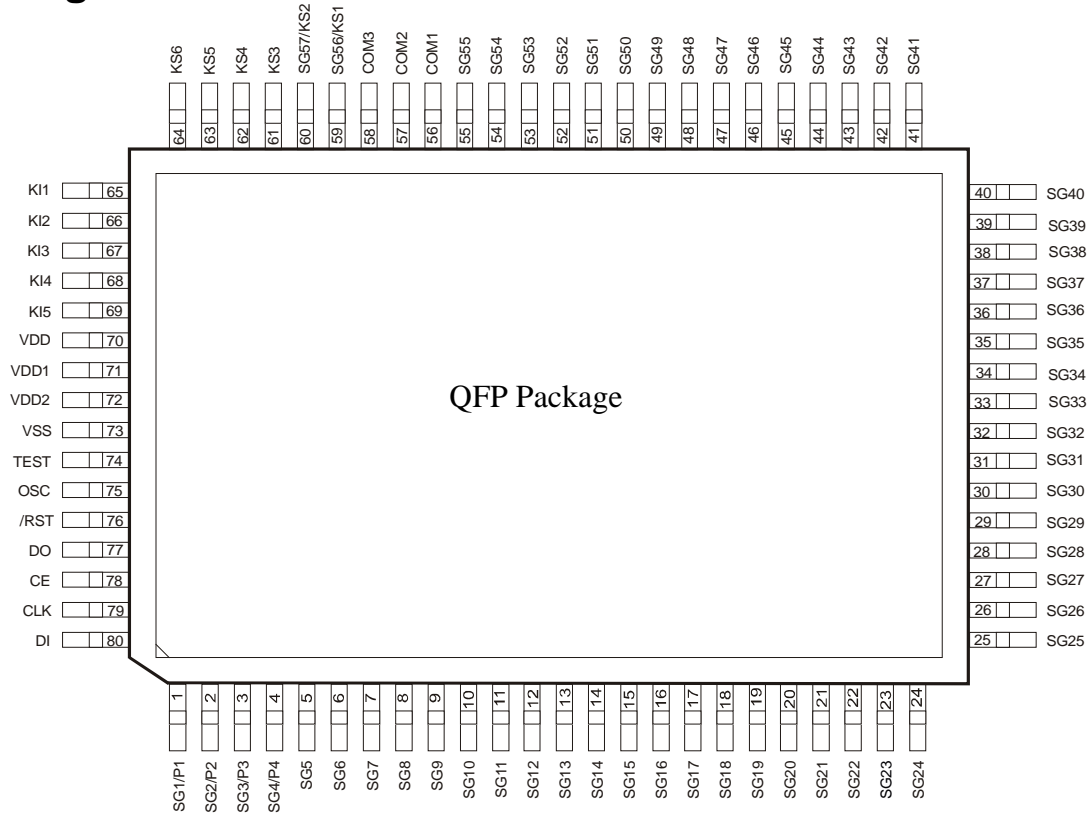

LCD Driver IC with Key Input Function

PT6583

1/2 Bias Application Circuit (for Normal LCD Panels)

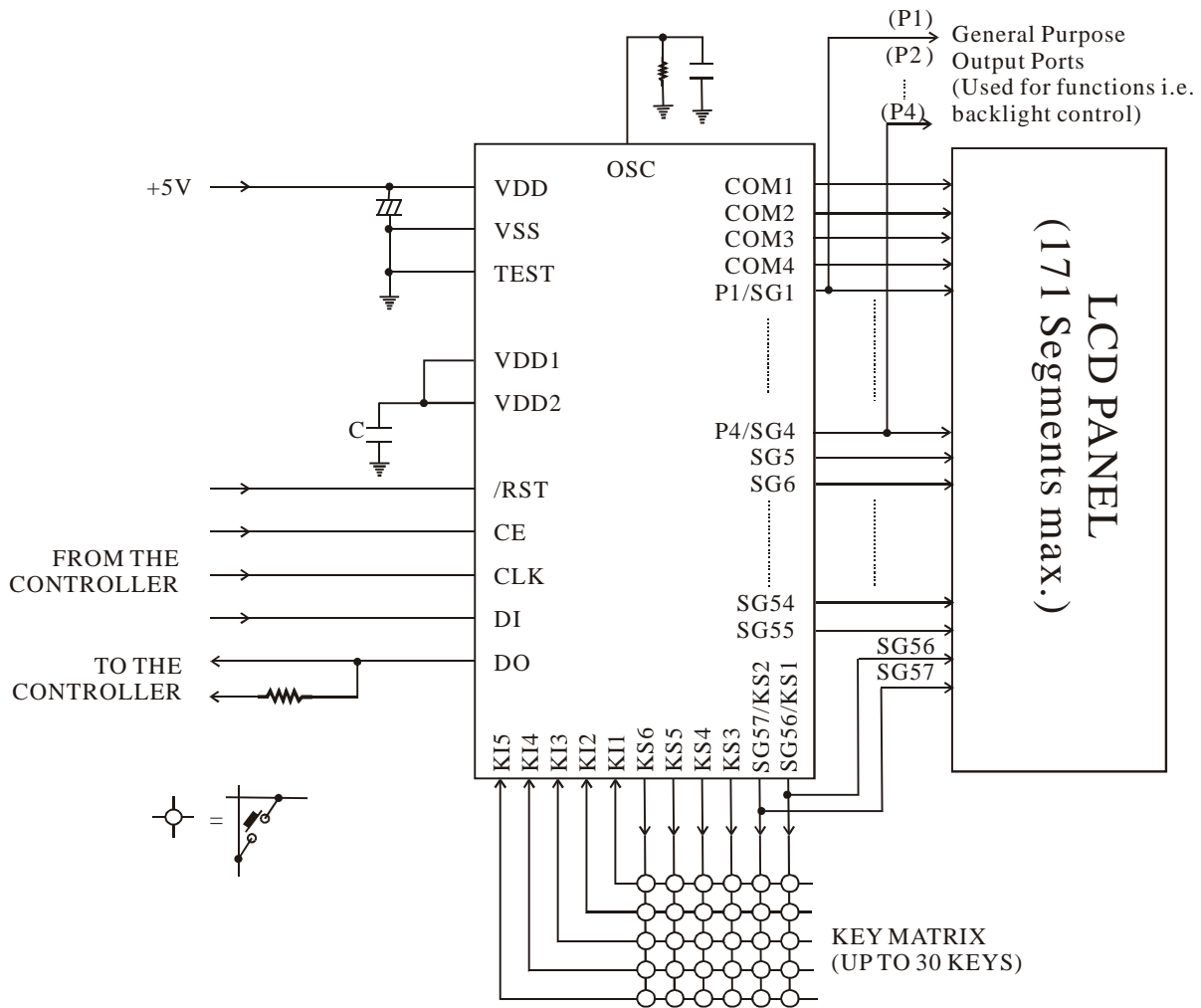

- Notes:
1. A capacitor can be connected to the power supply line to make the Power Supply Voltage VDD rise time (when power is applied) and the power supply Voltage VDD fall time (when power drops) are at least 1ms when PT6583 is reset via VDET.
 2. If the /RST Pin is not used to initiate the System Reset Function, it must be connected to VDD.
 3. The DO Pin is an open-drain output and therefore needs a pull-up resistor. This resistor must be between 1k to 10k Ohms. The value of this resistor must be in accordance with that the capacitance of the external wiring so that the signal waveforms are in proper form.
 4. $C \geq 0.047\mu\text{F}$

LCD Driver IC with Key Input Function

PT6583

1/3 Bias Application Circuit 2 (for Normal LCD Panels)

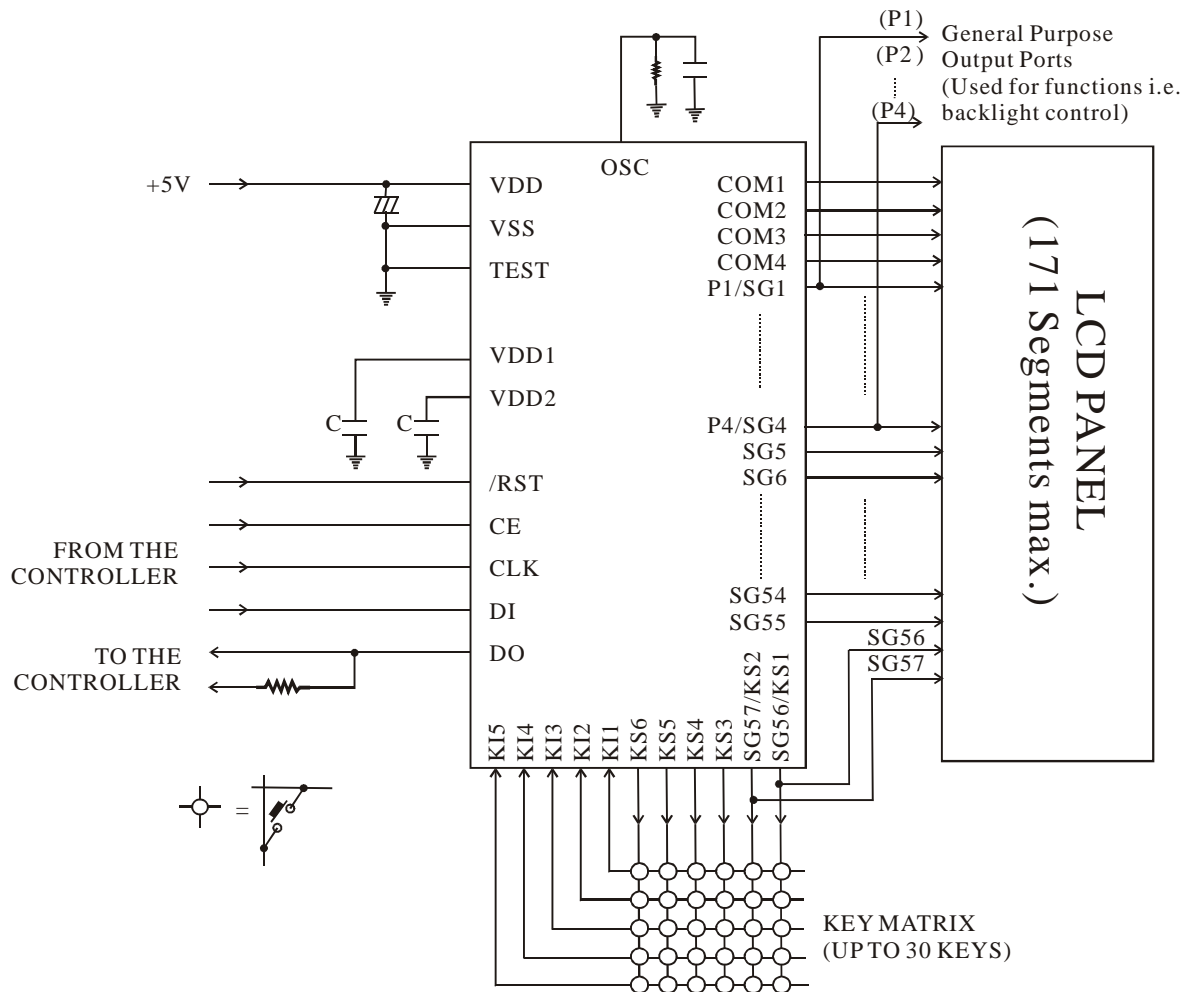

- Notes:
1. A capacitor can be connected to the power supply line to make the Power Supply Voltage VDD rise time (when power is applied) and the power supply Voltage VDD fall time (when power drops) are at least 1ms when PT6583 is reset via VDET.
 2. If the /RST Pin is not used to initiate the System Reset Function, it must be connected to VDD.
 3. The DO Pin is an open-drain output and therefore needs a pull-up resistor. This resistor must be between 1k to 10k Ohms. The value of this resistor must be in accordance with that the capacitance of the external wiring so that the signal waveforms are in proper form.
 4. $C \geq 0.047\mu\text{F}$

LCD Driver IC with Key Input Function

PT6583

1/3 Bias Application Circuit (for Large Panels)

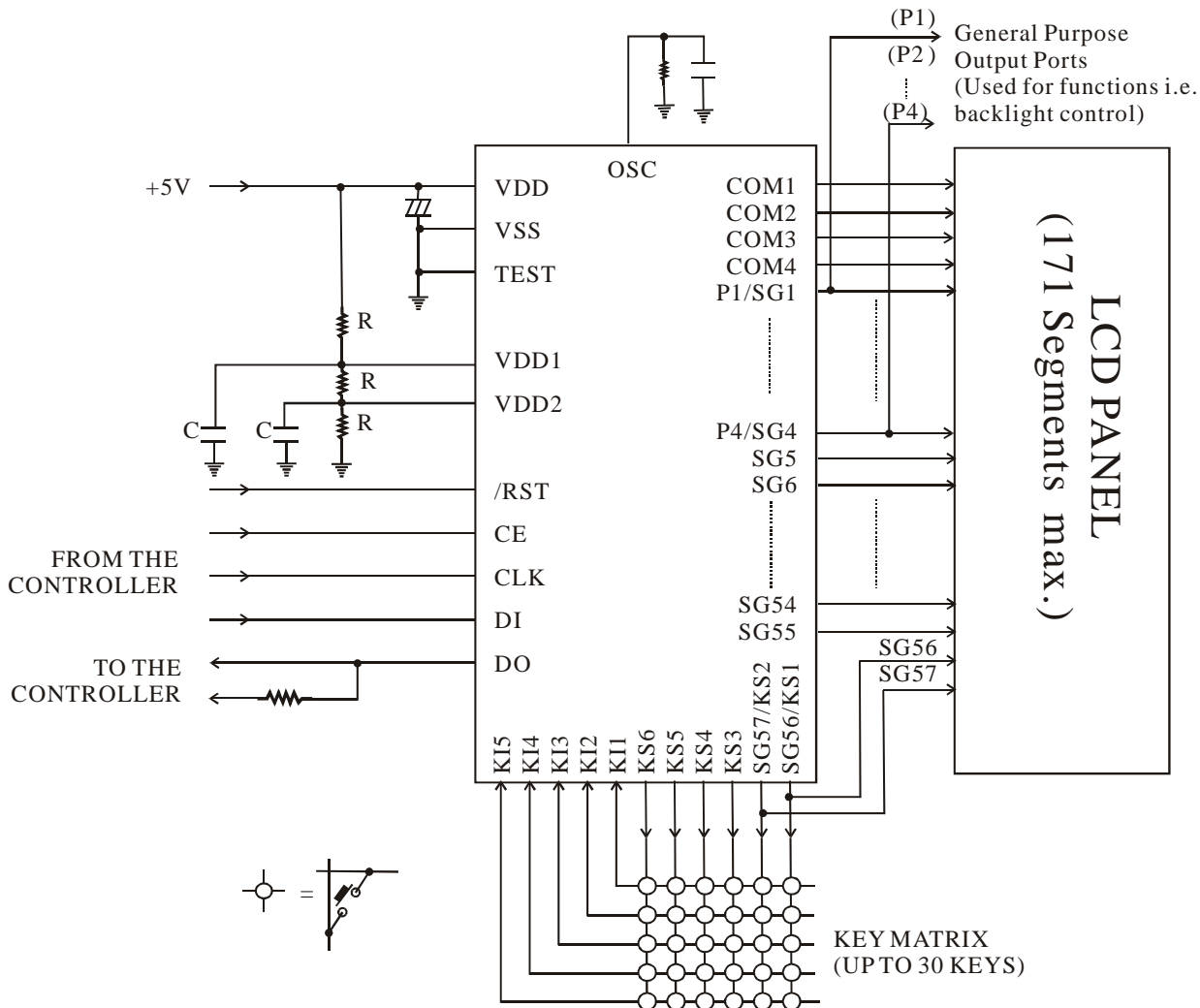

- Notes:
1. A capacitor can be connected to the power supply line to make the Power Supply Voltage VDD rise time (when power is applied) and the power supply Voltage VDD fall time (when power drops) are at least 1ms when PT6583 is reset via VDET.
 2. If the /RST Pin is not used to initiate the System Reset Function, it must be connected to VDD.
 3. The DO Pin is an open-drain output and therefore needs a pull-up resistor. This resistor must be between 1k to 10k Ohms. The value of this resistor must be in accordance with that the capacitance of the external wiring so that the signal waveforms are in proper form.
 4. $C \geq 0.047\mu F$

LCD Driver IC with Key Input Function

PT6583

ORDERING INFORMATION

Valid Part Number	Package Type
PT6583	80 pins, QFP package
PT6583-LQ	80 pins, LQFP package