

## Schematic:

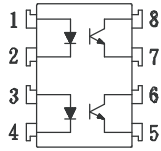

For dimensions and pin-outs, see the last page of this document.

## Ordering:

Suffix to Standard Part Number

- V = VDE Compliant
- G = 10mm Lead Spread
- S = Surface Mount Lead-form
- T = Tape & Reel

## Features:

1. Current transfer ratio  
(CTR:MIN.50% at  $I_F=5mA$   $V_{ce}=5V$ )
2. High isolation voltage between input and output  
(Viso:5300Vrms).
3. Compact dual-in-line package.

## Equivalents:

This part equals/exceeds all specifications of:

- ISP321-2, 521-2, 621-2
- ISP827
- PC827
- PS2501-2
- TIL192, A, B
- TLP321-2, 521-2, 621-2

## Absolute Maximum Ratings:

(Ta=25°C)

	Parameter	Symbol	Rating	Unit
Input	Forward current	$I_F$	50	mA
	Peak forward current	$I_{FM}$	1	A
	Reverse voltage	$V_R$	6	V
	Power dissipation	$P_D$	70	mW
Output	Collector-emitter voltage	$V_{CEO}$	60	V
	Emitter-collector voltage	$V_{ECO}$	6	V
	Collector current	$I_C$	50	mA
	Collector power dissipation	$P_C$	150	mW
Total power dissipation		$P_{tot}$	200	mW
Isolation voltage 1 minute		Viso	5300	Vrms
Operating temperature		$T_{opr}$	-55 to +100	°C
Storage temperature		$T_{stg}$	-55 to +125	°C
Soldering temperature 10 second		$T_{sol}$	260	°C

## Electrical Characteristics:

(Ta=25°C)

	Parameter	Symbol	Conditions	MIN.	TYP.	MAX.	Unit
Input	Forward voltage	$V_F$	$I_F=20mA$	—	1.2	1.4	V
	Peak forward voltage	$V_{FM}$	$I_{FM}=0.5A$	—	—	3.0	V
	Reverse current	$I_R$	$V_R=4V$	—	—	10	uA
	Terminal capacitance	$C_t$	$V=0, f=1kHz$	—	30	—	pF
Output	Collector dark current	$I_{CEO}$	$V_{CE}=20V$	—	—	0.1	uA
Transfer characteristics	Current transfer ratio	CTR	$I_F=5mA, V_{CE}=5V$	50	—	600	%
	Collector-emitter saturation voltage	$V_{CE(sat)}$	$I_F=20mA, I_C=1mA$	—	0.1	0.2	V
	Isolation resistance	Riso	DC500V	$5 \times 10^{10}$	$10^{11}$	—	ohm
	Floating capacitance	$C_f$	$V=0, f=1MHz$	—	0.6	1.0	pF
	Cut-off frequency	$f_c$	$V_{CC}=5V, I_C=2mA, R_L=100ohm$	—	80	—	kHz
	Response time (Rise)		$V_{CE}=2V, I_C=2mA, R_L=100ohm$	—	4	18	us
Response time (Fall)	$t_f$	—		3	18	us	

Classification table of current transfer ratio is shown below.

CTR CLASSIFICATIONS:	
MODEL #	CTR %
A	80 to 106
B	130 to 260
C	200 to 400
D	300 to 600

Fig.1 Current Transfer Ratio vs. Forward Current

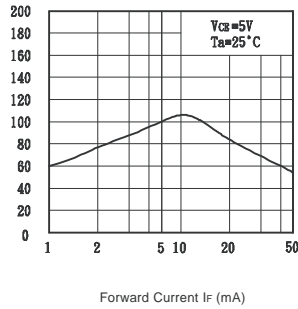

Fig.2 Collector Power Dissipation vs. Ambient Temperature

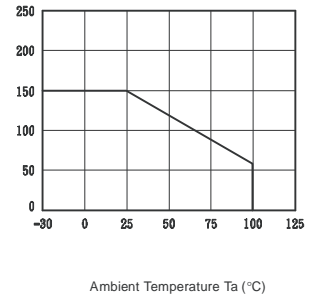

Fig.3 Collector Dark Current vs. Ambient Temperature

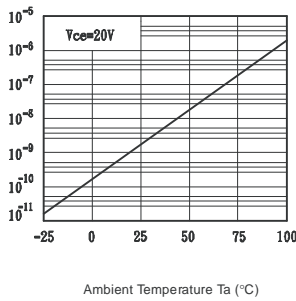

Fig.4 Forward Current vs. Ambient Temperature

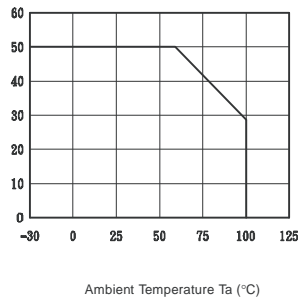

Fig.5 Forward Current vs. Forward Voltage

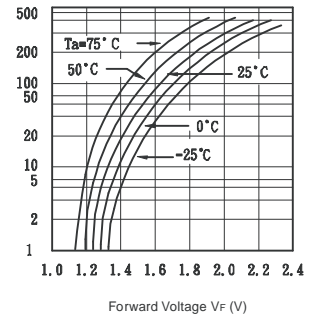

Fig.6 Collector Current vs. Collector-emitter Voltage

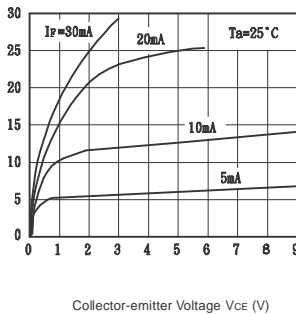

Fig.7 Relative Current Transfer Ratio vs. Ambient Temperature

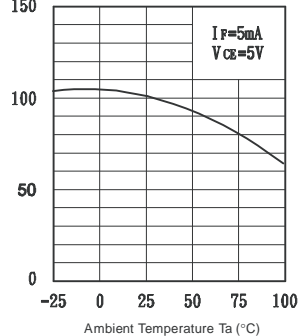

Fig.8 Collector-emitter Saturation Voltage vs. Ambient Temperature

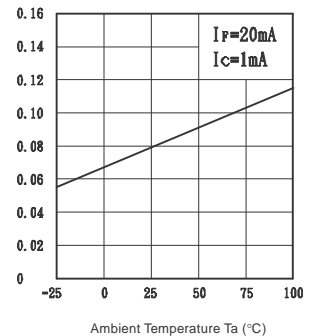

Fig.9 Collector-emitter Saturation Voltage vs. Forward Current

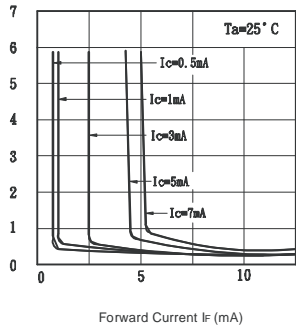

Fig.10 Response Time vs. Load Resistance

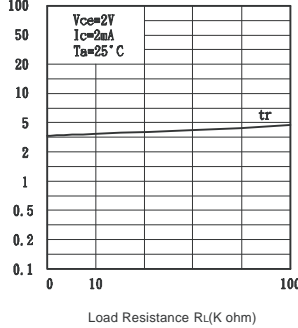

Fig.11 Response Time vs. Load Resistance

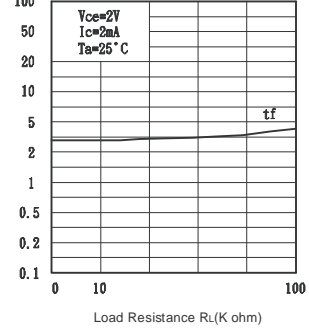

Fig.7 : 8-pin DIP type

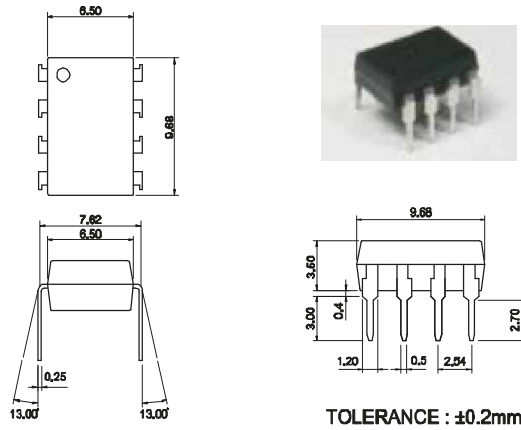

Fig.8 : 8-pin SMD type

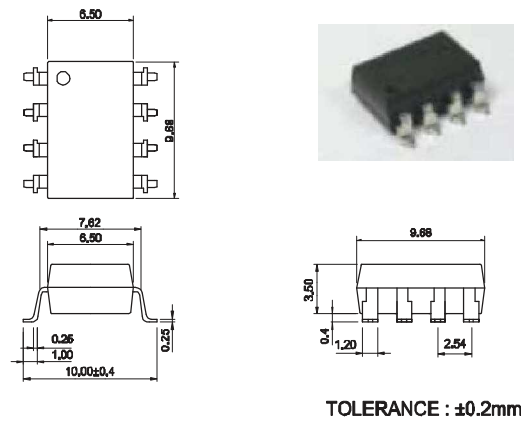

Fig.9 : 8-pin<sup>G</sup> type

