

# MS4525DO



- PCB Mounted Digital Output Transducer
- Combination Temperature and Pressure
- I<sup>2</sup>C or SPI Protocol
- Differential, Gage, Absolute & Compound
- Temperature Compensated
- 3.3 or 5.0 Vdc Supply Voltage
- Low Power Option Available (standby < 1uA)

## DESCRIPTION

The MS4525DO is a small, ceramic based, PCB mounted pressure transducer from Measurement Specialties. The transducer is built using Measurement Specialties' proprietary UltraStable™ process and the latest CMOS sensor conditioning circuitry to create a low cost, high performance Digital Output Pressure (14bit) and Temperature (11bit) transducer designed to meet the strictest requirements from OEM customers.

The MS4525DO is fully calibrated and temperature compensated with a total error band (TEB) of less than 1.0% over the compensated pressure range. The sensor operates from single supply of either 3.3 or 5.0Vdc.

The rugged ceramic transducer is available in side port, top port, and manifold mount and can measure absolute, gauge, differential or compound pressure from 1 to 150 psi. The 1/8" barbed pressure ports mate securely with 3/32" ID tubing.

## FEATURES

- PSI Pressure Ranges
- PCB Mountable
- Digital Output
- Barbed Pressure Ports

## APPLICATIONS

- Factory Automation
- Altitude and Airspeed Measurements
- Medical Instruments
- Leak Detection

## STANDARD RANGE (PSI)

Pressure	Absolute	Gauge	Differential	Compound
1		DS, SS, TP, MM	DS, SS, TP, MM	SS, TP
2		DS, SS, TP, MM	DS, SS, TP, MM	SS, TP
5		DS, SS, TP, MM	DS, SS, TP, MM	SS, TP
15	SS, TP	DS, SS, TP, MM	DS, MM	SS, TP
30	SS, TP	DS, SS, TP, MM	DS, MM	SS, TP
50	SS, TP	DS, SS, TP, MM	DS, MM	SS, TP
100	SS, TP	DS, SS, TP, MM	DS, MM	SS, TP
150	SS, TP	DS, SS, TP, MM	DS, MM	SS, TP

See Package Configurations: DS= Dual Side Port, SS= Single Side Port, TP= Top Port, MM= Manifold Mount

# MS4525DO

## BLOCK DIAGRAM

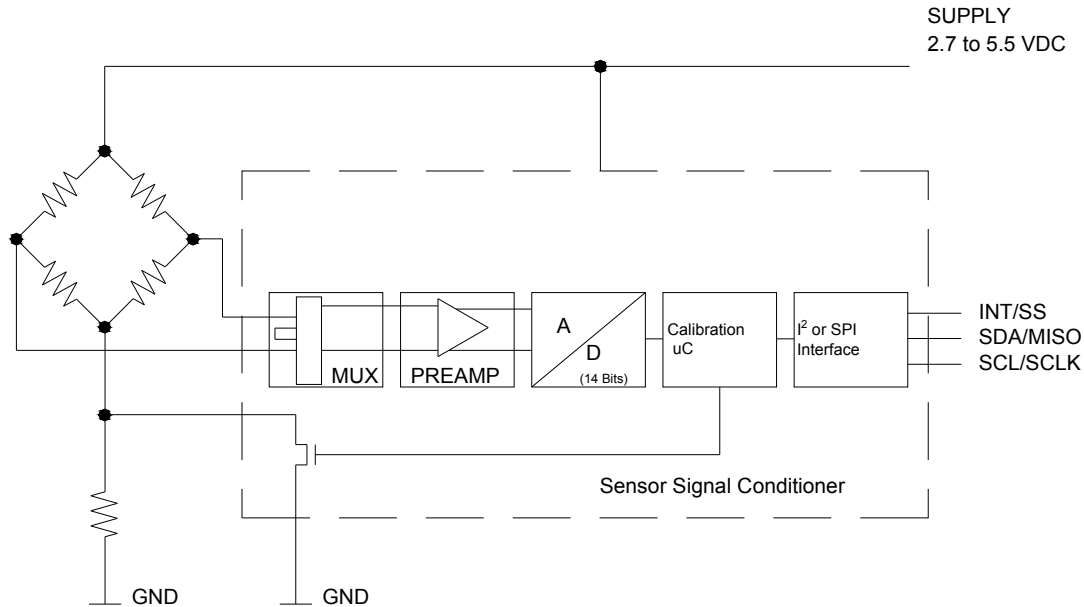

## APPLICATION SCHEMATIC

## ABSOLUTE MAXIMUM RATINGS

Parameter	Conditions	Min	Max	Unit	Notes
Supply Voltage	T <sub>A</sub> = 25 °C	2.7	5.5	V	
Output Current	T <sub>A</sub> = 25°C		3	mA	
Voltage on any Pin	T <sub>A</sub> = 25°C	-0.3	V <sub>supply</sub> + 0.3	V	
Storage Temperature		-40	+125	°C	
Humidity	T <sub>A</sub> = 25°C		95	%RH	Non Condensing
Overpressure	T <sub>A</sub> = 25 °C, both Ports		300	psi	
Burst Pressure	T <sub>A</sub> = 25 °C, Port 1		3X	psi	See Table 1
ESD	HBM	-4	+4	kV	EN 61000-4-2
Solder Temperature		250°C, 5 sec max.			

**TABLE 1- BURST PRESSURE BY RANGE AND PACKAGE STYLE**

Range	DS	SS, TP, MM	Unit
001	30	30	psi
002	15	30	psi
005	15	30	psi
015	45	90	psi
030	90	200	psi
050	150	300	psi
100	300	300	psi
150	300	300	psi

# MS4525DO

## ENVIRONMENTAL SPECIFICATIONS

Parameter	Conditions
Mechanical Shock	Mil Spec 202F, Method 213B, Condition C, 3 Drops
Mechanical Vibration	Mil Spec 202F, Method 214A, Condition 1E, 1Hr Each Axis
Thermal Shock	100 Cycles over Storage Temperature, 30 minute dwell
Life	1 Million FS Cycles

## PERFORMANCE SPECIFICATIONS

Supply Voltage<sup>1</sup>: 5.0V or 3.3 Vdc

Reference Temperature: 25°C (unless otherwise specified)

PARAMETERS	MIN	TYP	MAX	UNITS	NOTES
Pressure Accuracy	-0.25		0.25	%Span	2
Total Error Band (TEB)	-1.0		1.0	%Span	3,7
Temperature Accuracy		1.5		°C	4
Supply Current		3		mA	7
Compensated Temperature	-10		85	°C	5
Operating Temperature	-25		+105	°C	
Output Pressure Resolution			14	bits	
Output Temperature Resolution	8		11	bits	
Response Time		1.5		mS	6
Start Time to Data Ready		4.3		mS	6
Weight		3		grams	

Media Non-Corrosive Dry Gases Compatible with Ceramic, Silicon, Pyrex, RTV, Gold, Aluminum and Epoxy. See "Wetted Material by Port Designation" chart below.

### Notes

- Output is not ratiometric to supply voltage.
- The maximum deviation from a best fit straight line (BFSL) fitted to the output measured over the pressure range at 25C. Includes all errors due to pressure non linearity, hysteresis, and non repeatability.
- Total pressure error band includes all accuracy errors, thermal errors over the compensated temperature range and span and offset calibration tolerances. For ideal sensor output with respect to input pressure and temperature, reference Transfer Function charts below.
- The maximum deviation from a best fit straight line (BFSL) fitted to the output measured over the compensated temperature range.
- For errors beyond the compensated temperature range, see Temperature Error Multiplier chart below.
- Start time to data ready is the time to get valid data after POR (power on reset). The time to get subsequent valid data is then specified by the response time specification.
- This product can be configured for custom OEM requirements, contact factory for lower power consumption or higher accuracy.

# MS4525DO

## Pressure and Temperature Transfer Function Chart

Pressure Transfer Functions

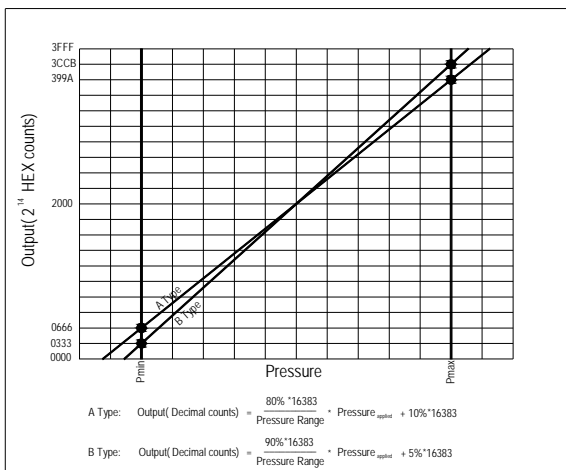

Temperature Transfer Functions

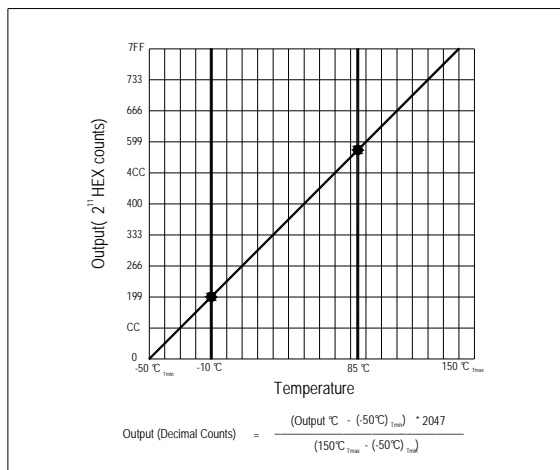

Temperature Output vs Counts

Output °C	Digital Counts (decimal)	Digital Counts (hex)
-50	0	0 X 0000
0	511	0 X 01FF
10	614	0 X 0266
25	767	0 X 02FF
50	1023	0 X 03FF
85	1381	0 X 0565
150	2047	0 X 07FF

## Temperature Error Multiplier Chart

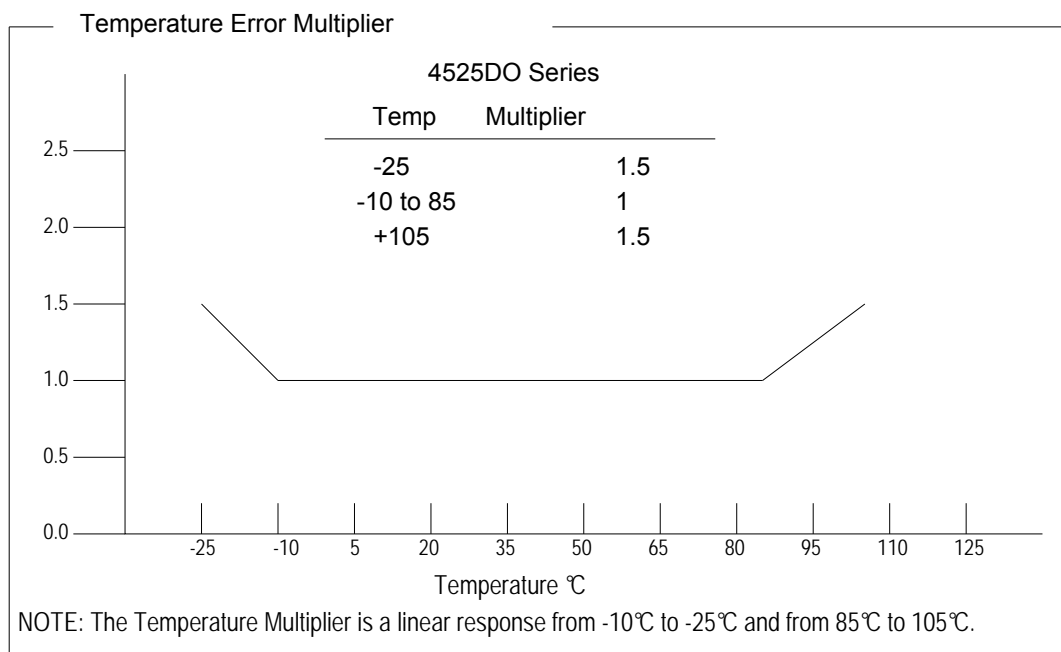

# MS4525DO

## PACKAGE, PINOUT, AND PRESSURE TYPE CONFIGURATION

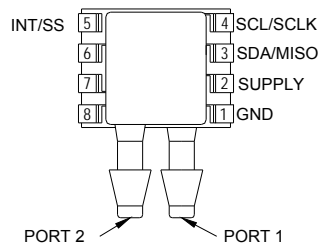

4525DO-DSvxxxYP

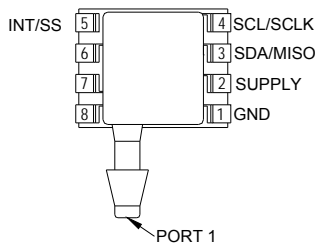

4525DO-SSvxxxYP

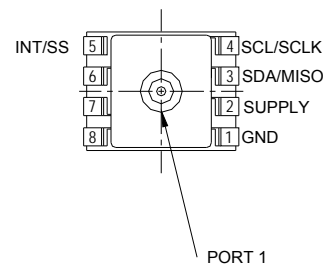

4525DO-TPvxxxYP

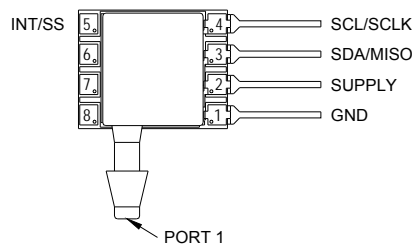

4525DO-SSvxxxYL

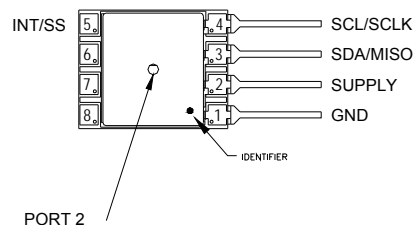

4525DO-MMvxxxYL

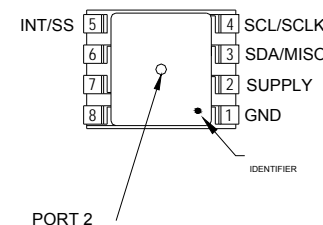

4525DO-MMvxxxYP

Pin Name	Pin	Function
GND	1	Ground
SUPPLY	2	Positive Supply Voltage
SDA MISO	3	I2C Data                      SPI Data
SCL SCLK	4	I2C Clock                      SPI Clock
INT SS	5	I2C Interrupt                      SPI Chip Select

Pressure Type	Pmin	Pmax	Description
Absolute	0psiA	+Prange	Output is proportional to the difference between 0psiA (Pmin) and pressure applied to Port 1.
Differential/ Bidirectional	-Prange	+Prange	Output is proportional to the difference between Port 1 and Port 2. Output swings positive when Port 1 > Port 2. Output is 50% of total counts when Port 1=Port 2.
Gauge	0psiG	+Prange	Output is proportional to the difference between 0psiG (Pmin) and Port 1. Output swings positive when Port 1 > Port 2.
Compound	-15psiG	+Prange	Output is proportional to the difference between -15psiG pressure (Pmin) and pressure applied to Port 1.

Prange is equal to the maximum full scale pressure specified in the ordering information.

### Wetted Material by Port Designation

Style	Port	Material						
		Ceramic	Silicon	Pyrex	RTV	Gold	Aluminum	Epoxy
DS, MM	Port 1	X	X	X	X			X
	Port 2	X	X	X	X	X	X	X
SS, TP	Port 1	X	X	X	X	X	X	X

"X" Indicates Wetted Material

# MS4525DO

## DIMENSIONS

DIMENSIONS ARE IN INCHES [mm]

### 4525DO-DSvxxxP

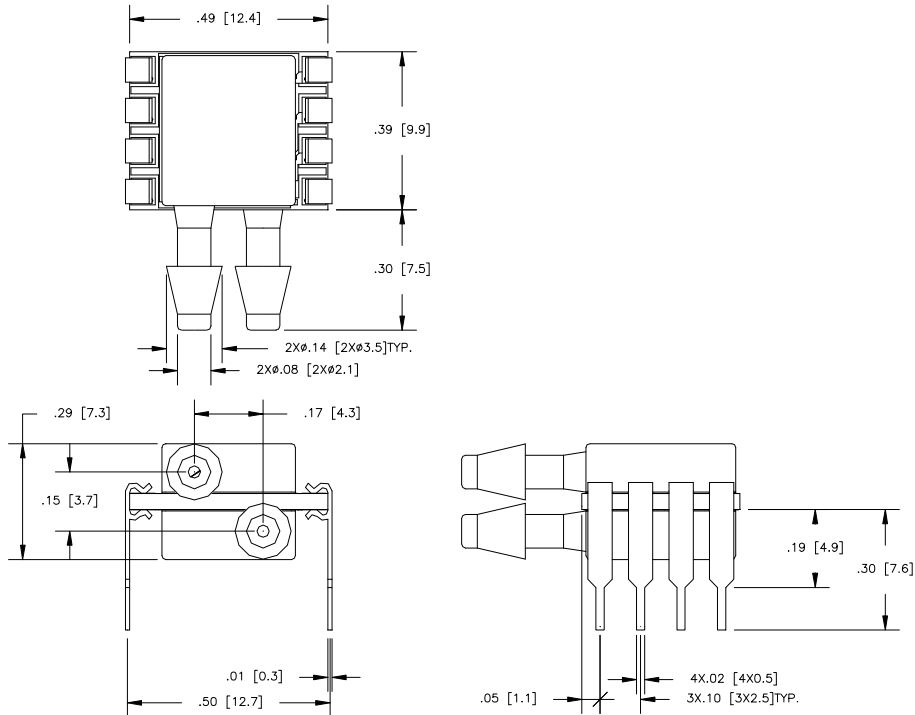

### 4525DO-DSvxxxS

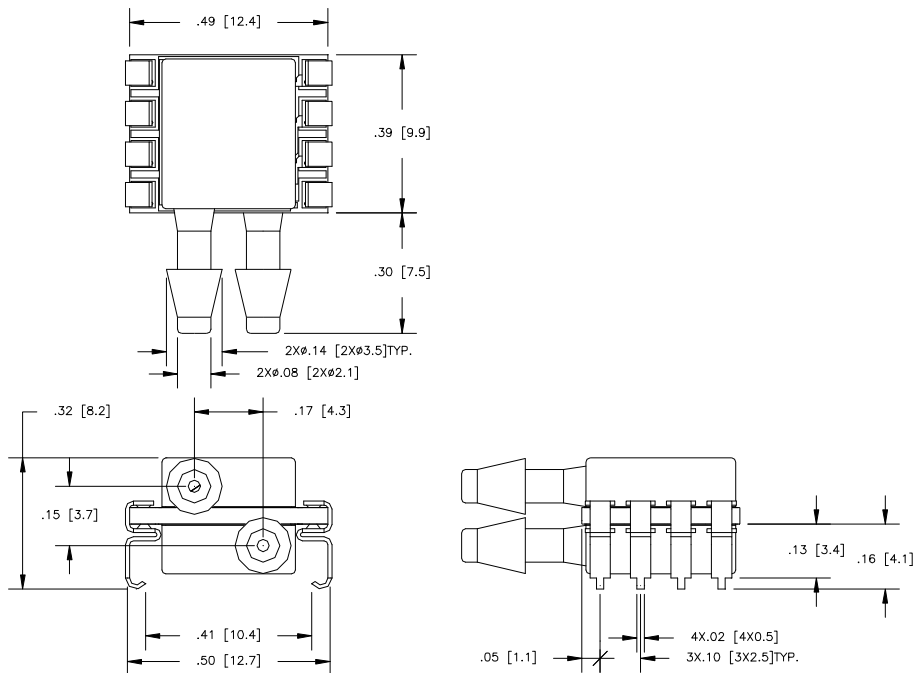

# MS4525DO

DIMENSIONS ARE IN INCHES [mm]

## 4525DO-SSvxxxYP

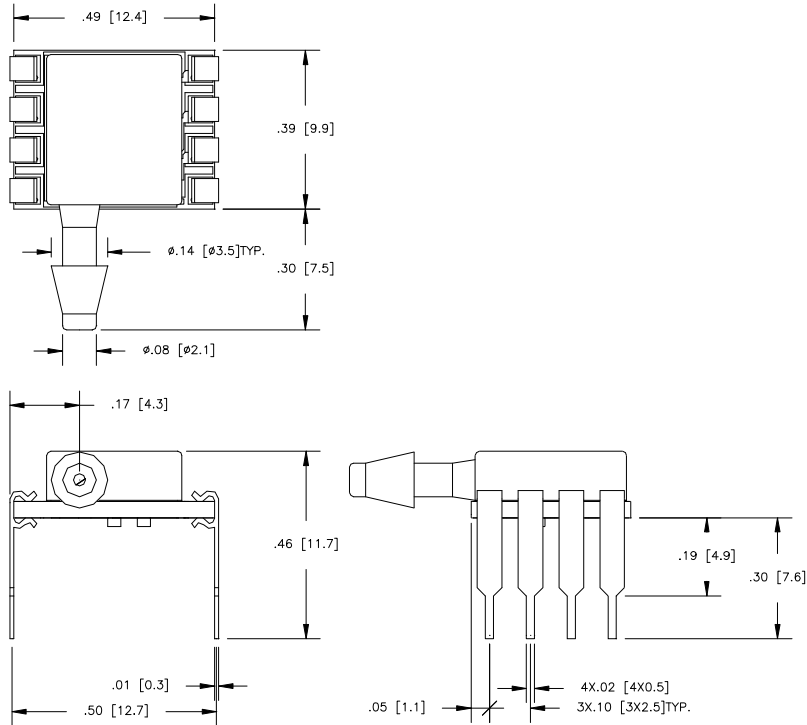

## 4525DO-SSvxxxYS

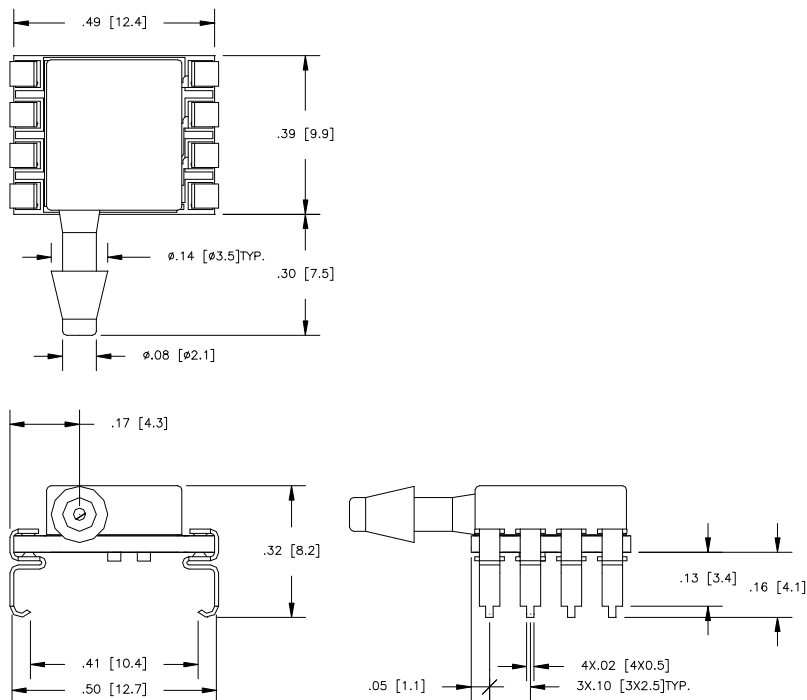

# MS4525DO

DIMENSIONS ARE IN INCHES [mm]

## 4525DO-TPvxxxP

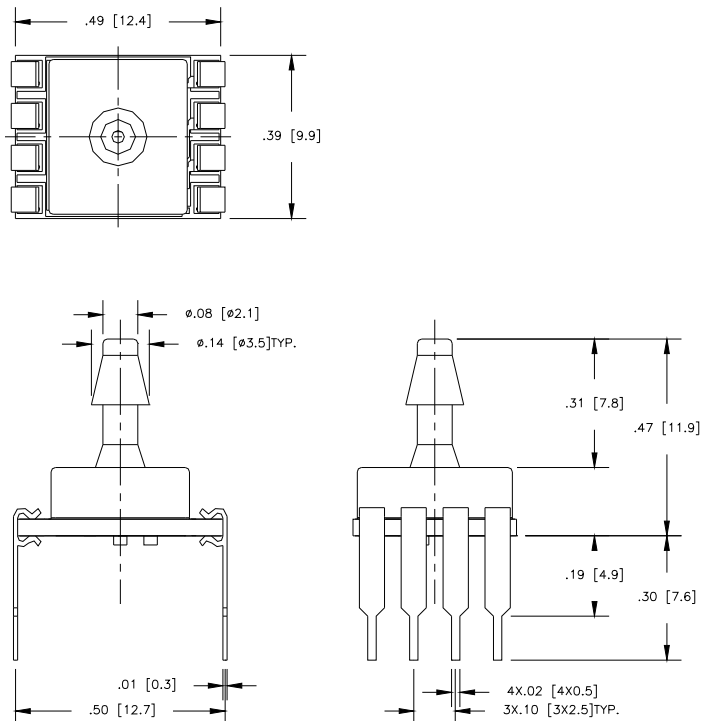

## 4525DO-TPvxxxS

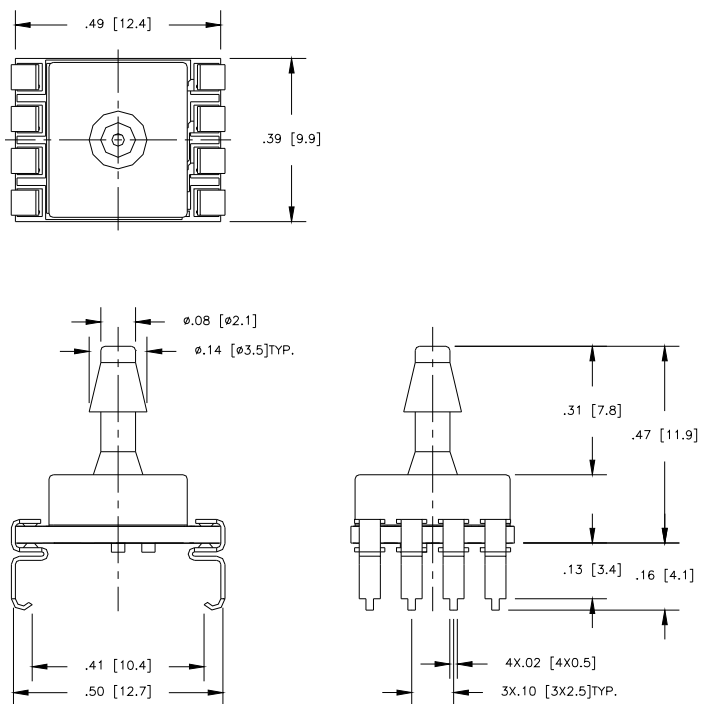



# MS4525DO

DIMENSIONS ARE IN INCHES [mm]

## 4525DO-MMvxxxL

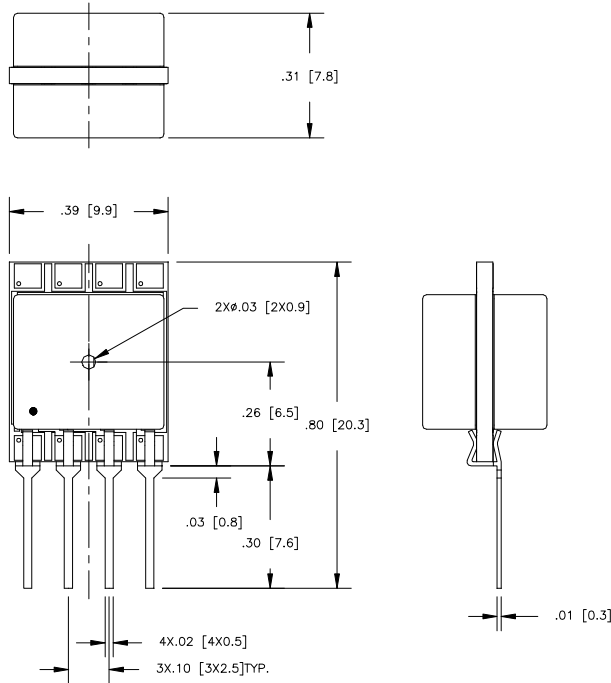

## 4525DO-SSvxxxL

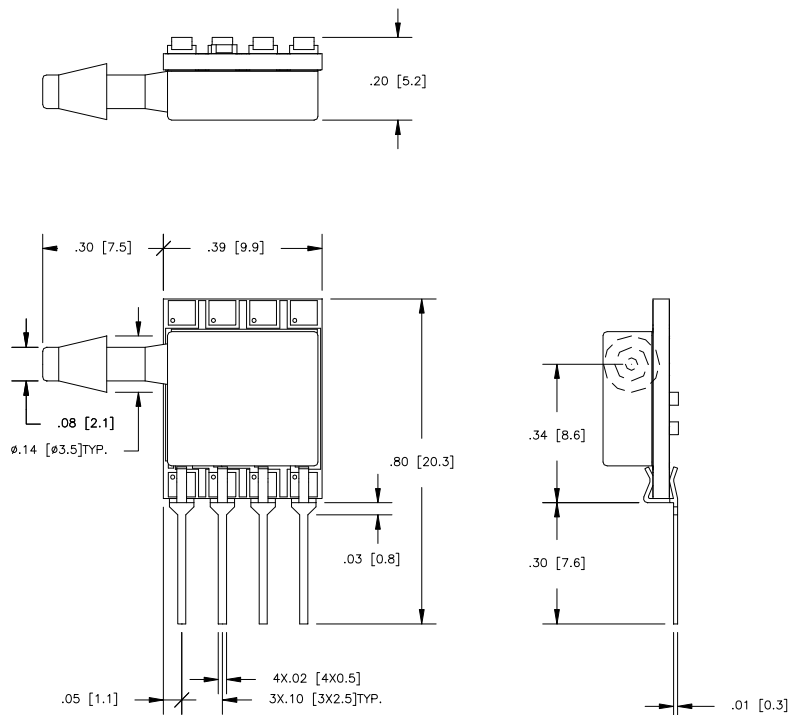

# MS4525DO

DIMENSIONS ARE IN INCHES [mm]

4525DO-MMvxxxyP

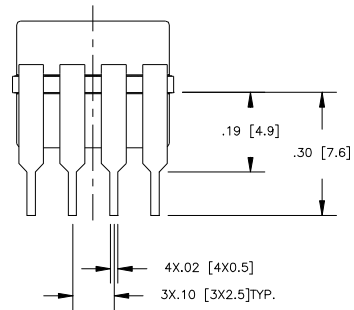
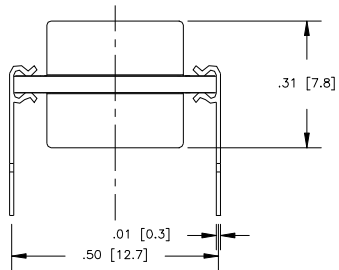
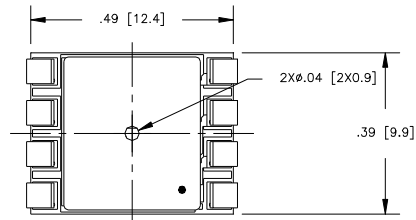

# MS4525DO

## I2C AND SPI INTERFACE SPECIFICATIONS

### 1. I2C interface Specification

The serial interface of the 4515DO/4525DO series is optimized in terms of sensor readout and power consumption when the factory setting for I2C. For detailed specifications of the I2C protocol, see The I2C Bus Specification, Version 2.1, January 2000.

#### 1.1 Interface connection-external

Bi-directional bus lines are implemented by the devices (master and slave) using open-drain output stages and a pull-up resistor connected to the positive supply voltage. The recommended pull-up resistor value depends on the system setup (capacitance of the circuit or cable and bus clock frequency). In most cases, 1 k $\Omega$  is a reasonable choice. The capacitive loads on SDA and SCL line have to be the same. It is important to avoid asymmetric capacitive loads.

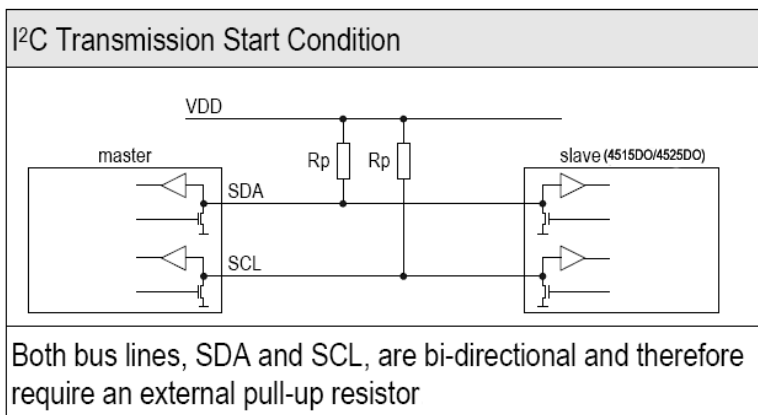

#### 1.2 I2C Address

The I2C address consists of a 7-digit binary value. The factory setting for I2C slave address is 0x28, 0x36 or 0x46 depending on the interface type selected from the ordering information. The address is always followed by a write bit (0) or read bit (1). The default hexadecimal I2C header for read access to the sensor is therefore 0x51, 0x6D, 0x8D respectively, based on the ordering information.

#### 1.3 INT/SS pin

When programmed as an I2C device, the INT/SS pin operates as an interrupt. The INT/SS pin rises when new output data is ready and falls when the next I2C communication occurs.

#### 1.4 Transfer sequences

**Transmission START Condition (S):** The START condition is a unique situation on the bus created by the master, indicating to the slaves the beginning of a transmission sequence (the bus is considered busy after a START).

# MS4525DO

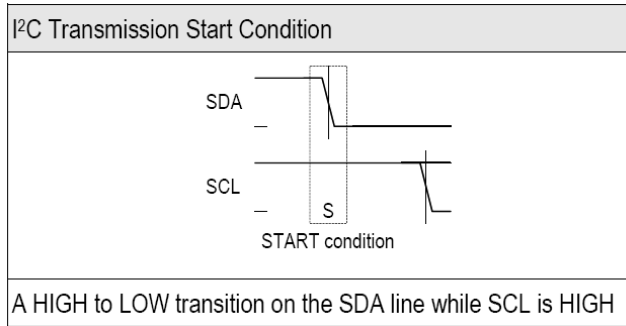

**Transmission STOP Condition (P):** The STOP condition is a unique situation on the bus created by the master, indicating to the slaves the end of a transmission sequence (the bus is considered free after a STOP).

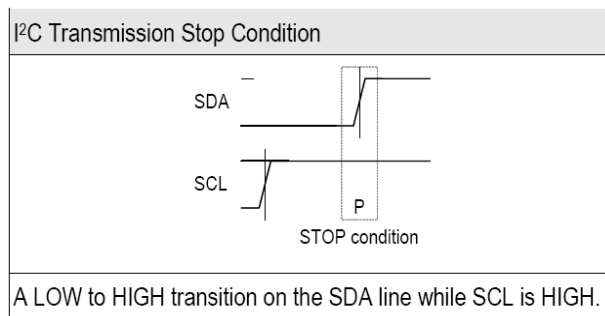

**Acknowledge (ACK) / Not Acknowledge (NACK):** Each byte (8 bits) transmitted over the I<sup>2</sup>C bus is followed by an acknowledge condition from the receiver. This means that after the master pulls SCL low to complete the transmission of the 8th bit, SDA will be pulled low by the receiver during the 9th bit time. If after transmission of the 8th bit the receiver does not pull the SDA line low, this is considered to be a NACK condition.

If an ACK is missing during a slave to master transmission, the slave aborts the transmission and goes into idle mode.

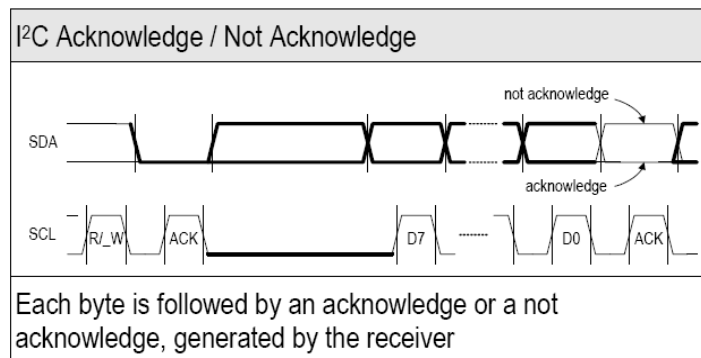

**Handshake procedure (Hold Master):** In a master-slave system, the master dictates when the slaves will receive or transmit data. However, in some situations a slave device may need time to store received data or prepare data to be transmitted. Therefore, a handshake procedure is required to allow the slave to indicate termination of internal processing

# MS4525DO

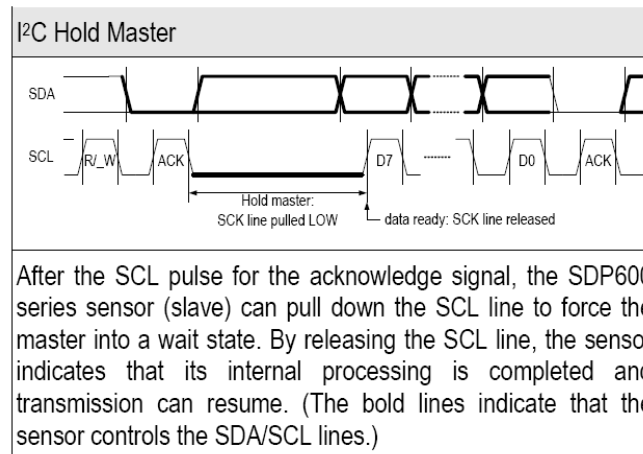

## 1.5 Data transfer format

Data is transferred in byte packets in the I2C protocol, which means in 8-bit frames. Each byte is followed by an acknowledge bit. Data is transferred with the most significant bit (MSB) first.

A data transfer sequence is initiated by the master generating the Start condition (S) and sending a header byte. The I2C header consists of the 7-bit I2C device address and the data direction bit (R/W).

The value of the R/W bit in the header determines the data direction for the rest of the data transfer sequence. If R/W = 0 (WRITE) the direction remains master-to-slave, while if R/W = 1 (READ) the direction changes to slave-to-master after the header byte.

## 1.6 Command Set and data Transfer Sequences

The I2C master command starts with the 7bit slave address with the 8th bit =1 (READ). The sensor as the slave sends an acknowledge (ACK) indicating success. The sensor has four I2C read commands: Read\_MR, Read\_DF2, Read\_DF3, and Read\_DF4. Figure 1.6 shows the structure of the measurement packet for three of the four I2C read commands, which are explained in sections 1.6.1 and 1.6.2

# MS4525DO

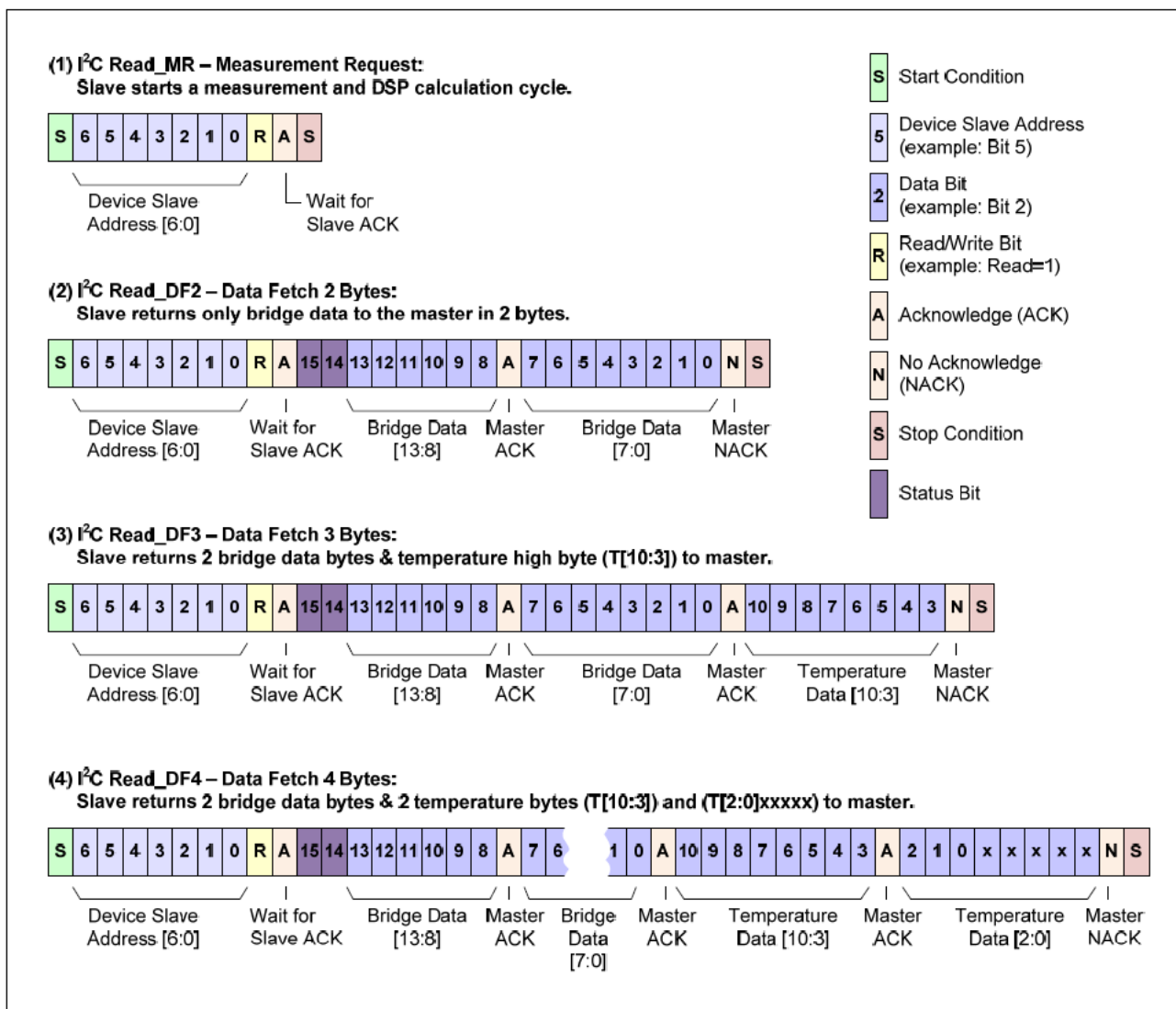

Figure 1.6 – I2C Measurement Packet Reads

## 1.6.1 I2C Read\_DF (Data Fetch)

For Data Fetch commands, the number of data bytes returned by the sensor is determined by when the master sends the NACK and stop condition. For the Read\_DF3 data fetch command (Data Fetch 3 Bytes; see example 3 in Figure 1.6), the sensor returns three bytes in response to the master sending the slave address and the READ bit (1): two bytes of bridge data with the two status bits as the MSBs and then 1 byte of temperature data (8-bit accuracy). After receiving the required number of data bytes, the master sends the NACK and stop condition to terminate the read operation. For the Read\_DF4 command, the master delays sending the NACK and continues reading an additional final byte to acquire the full corrected 11-bit temperature measurement. In this case, the last 5 bits of the final byte of the packet are undetermined and should be masked off in the application. The Read\_DF2 command is used if corrected temperature is not required. The master terminates the READ operation after the two bytes of bridge data (see example 2 in Figure 1.6).

The two status bits (Bit 15 and Bit 14) give an indication of stale or valid data depending on their value. A returned value of 00 indicate “normal operation and good data packet” and a returned value of 10 indicate “stale data that has been already fetched”. Users that use “status bit” polling should select a frequency slower than 20% more than the response time.

# MS4525DO

## 2. SPI interface Specification

The SPI interface of sensor must be programmed for falling-edge MISO change.

### 2.1 SPI Read\_DF (Data Fetch)

The SPI interface will have data change after the falling edge of SCLK. The master should sample MISO on the rise of SCLK. The entire output packet is 4 bytes (32 bits). The high bridge data byte comes first, followed by the low bridge data byte. Then 11 bits of corrected temperature (T[10:0]) are sent: first the T[10:3]byte and then the {T[2:0],xxxxx} byte. The last 5 bits of the final byte are undetermined and should be masked off in the application. If the user only requires the corrected bridge value, the read can be terminated after the 2nd byte. If the corrected temperature is also required but only at an 8-bit resolution, the read can be terminated after the 3rd byte is read.

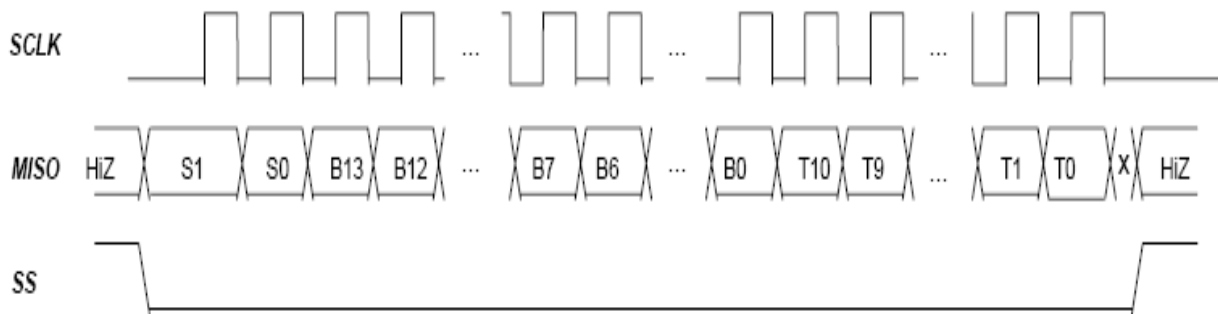

Packet = [ {S(1:0),B(13:8)}, {B(7:0)}, {T(10:3)},{T(2:0),xxxxx}] Where  
 S(1:0) = Status bits of packet (normal, command, busy, diagnostic)  
 B(13:8) = Upper 6 bits of 14-bit bridge data.  
 B(7:0) = Lower 8 bits of 14-bit bridge data.  
 T(10:3) = Corrected temperature data (if application does not require corrected temperature, terminate read early)  
 T(2:0),xxxxx = Remaining bits of corrected temperature data for full 11-bit resolution  
 HiZ = High impedance

**Figure 2.2 – SPI Output Packet with Falling Edge SPI\_Polarity**

# MS4525DO

## TIMING DIAGRAMS

### I2C INTERFACE PRRAMETERS

PARAMETERS	SYMBOL	MIN	TYP	MAX	UNITS
SCLK CLOCK FREQUENCY	F <sub>SCL</sub>	100		400	KHz
START CONDITION HOLD TIME RELATIVE TO SCL EDGE	t <sub>HDSTA</sub>	0.1			uS
MINIMUM SCL CLOCK LOW WIDTH @1	t <sub>LOW</sub>	0.6			uS
MINIMUM SCL CLOCK HIGH WIDTH @1	t <sub>HIGH</sub>	0.6			uS
START CONDITION SETUP TIME RELATIVE TO SCL EDGE	t <sub>SUSTA</sub>	0.1			uS
DATA HOLD TIME ON SDA RELATIVE TO SCL EDGE	t <sub>HDDAT</sub>	0			uS
DATA SETUP TIME ON SDA RELATIVE TO SCL EDGE	t <sub>SUDAT</sub>	0.1			uS
STOP CONDITION SETUP TIME ON SCL	t <sub>SUSTO</sub>	0.1			uS
BUS FREE TIME BETWEEN STOP AND START CONDITION	t <sub>BUS</sub>	2			uS

@1 COMBINED LOW AND HIGH WIDTHS MUST EQUAL OR EXCEED MINIMUM SCL PERIOD.

### I2C TIMING DIAGRAM

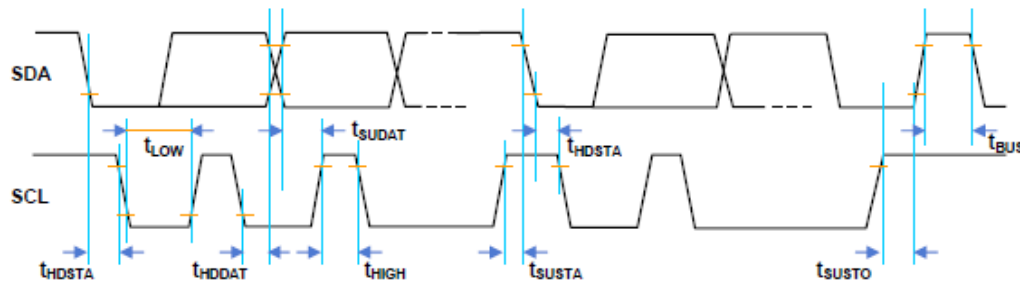

### SPI INTERFACE PRRAMETERS

PARAMETERS	SYMBOL	MIN	TYP	MAX	UNITS
SCLK CLOCK FREQUENCY	F <sub>SCL</sub>	50		800	KHz
SS DROP TO FIRST CLOCK EDGE	t <sub>HDSS</sub>	2.5			uS
MINIMUM SCL CLOCK LOW WIDTH @1	t <sub>LOW</sub>	0.6			uS
MINIMUM SCL CLOCK HIGH WIDTH @1	t <sub>HIGH</sub>	0.6			uS
CLOCK EDGE TO DATA TRANSITION	t <sub>CLKD</sub>	0		0.1	uS
RISE OF SS RELATIVE TO LAST CLOCK EDGE	t <sub>SUSS</sub>	0.1			uS
BUS FREE TIME BETWEEN RISE AND FALL OF SS	t <sub>BUS</sub>	2			uS

@1 COMBINED LOW AND HIGH WIDTHS MUST EQUAL OR EXCEED MINIMUM SCLK PERIOD.

### SPI TIMING DIAGRAM

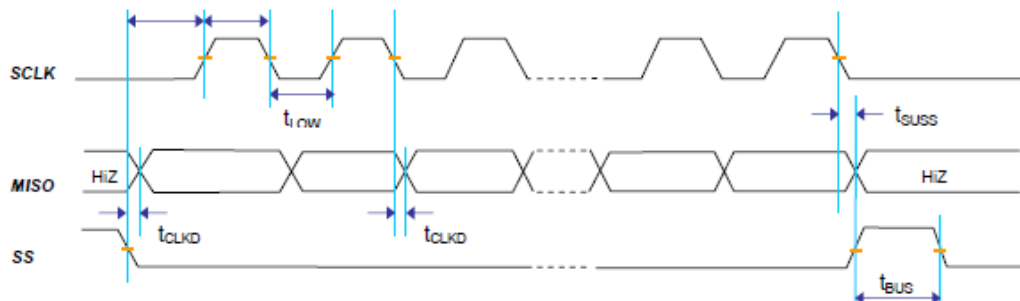



# MS4525DO

## ORDERING INFORMATION

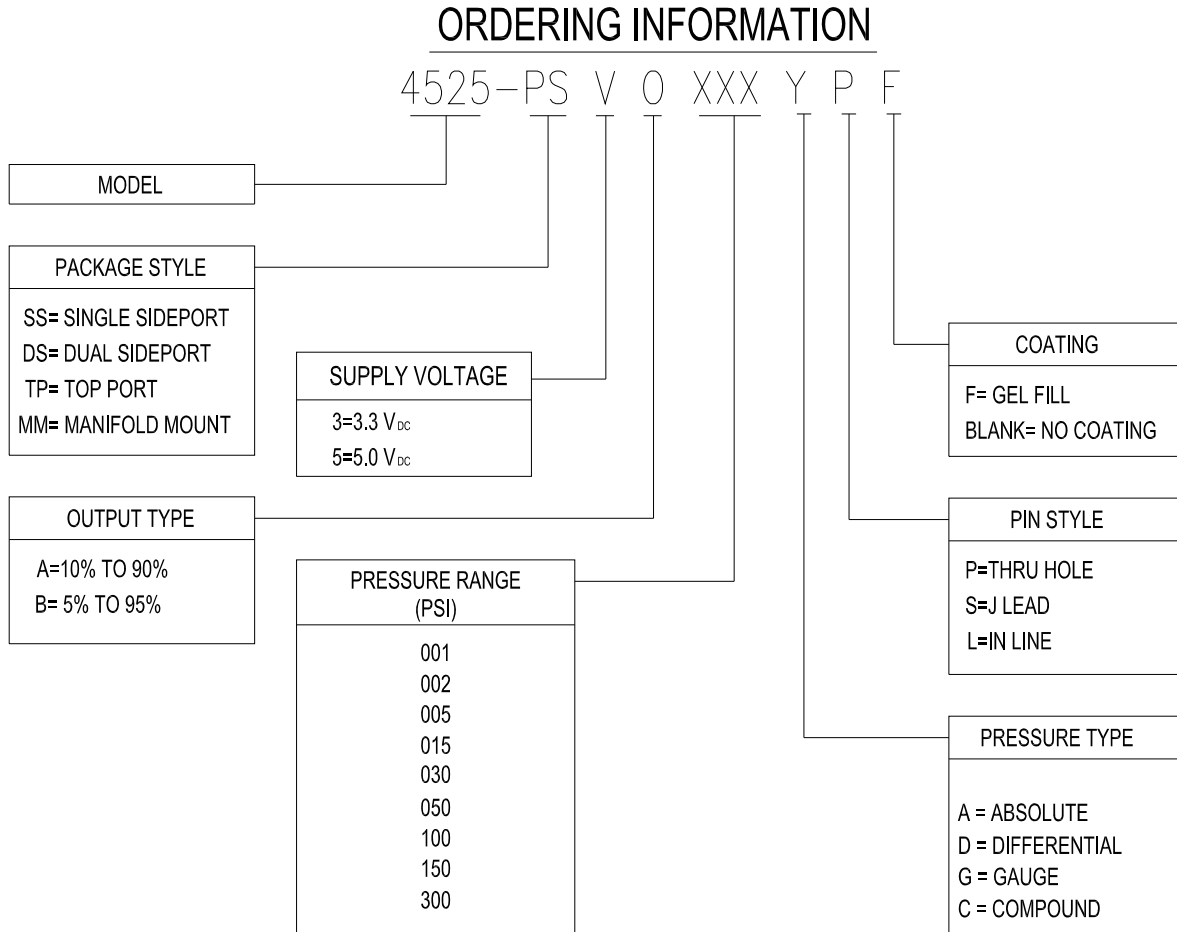

### NORTH AMERICA

Measurement Specialties  
 45738 Northport Loop West  
 Fremont, CA 94538  
 Tel: 1-800-767-1888  
 Fax: 1-510-498-1578  
 Sales: [pfg.cs.amer@meas-spec.com](mailto:pfg.cs.amer@meas-spec.com)

### EUROPE

Measurement Specialties  
 (Europe), Ltd.  
 26 Rue des Dames  
 78340 Les Clayes-sous-Bois, France  
 Tel: +33 (0) 130 79 33 00  
 Fax: +33 (0) 134 81 03 59  
 Sales: [pfg.cs.emea@meas-spec.com](mailto:pfg.cs.emea@meas-spec.com)

### ASIA

Measurement Specialties  
 (China), Ltd.  
 No. 26 Langshan Road  
 Shenzhen High-Tech Park (North)  
 Nanshan District, Shenzhen 518107  
 China  
 Tel: +86 755 3330 5088  
 Fax: +86 755 3330 5099  
 Sales: [pfg.cs.asia@meas-spec.com](mailto:pfg.cs.asia@meas-spec.com)

The information in this sheet has been carefully reviewed and is believed to be accurate; however, no responsibility is assumed for inaccuracies. Furthermore, this information does not convey to the purchaser of such devices any license under the patent rights to the manufacturer. Measurement Specialties, Inc. reserves the right to make changes without further notice to any product herein. Measurement Specialties, Inc. makes no warranty, representation or guarantee regarding the suitability of its product for any particular purpose, nor does Measurement Specialties, Inc. assume any liability arising out of the application or use of any product or circuit and specifically disclaims any and all liability, including without limitation consequential or incidental damages. Typical parameters can and do vary in different applications. All operating parameters must be validated for each customer application by customer's technical experts. Measurement Specialties, Inc. does not convey any license under its patent rights nor the rights of others.