

Three Phase AC Controller Modules

PSUT 65
PSUH 65

$I_{RMS} = 3 \times 65 \text{ A}$
 $V_{RRM} = 800-1600 \text{ V}$

Preliminary Data Sheet

V_{RSM} V_{DSM} (V)	V_{RRM} V_{DRM} (V)	Type
900	800	PSUT 65/08 PSUH 65/08
1300	1200	PSUT 65/12 PSUH 65/12
1500	1400	PSUT 65/14 PSUH 65/14
1700	1600	PSUT 65/16 PSUH 65/16

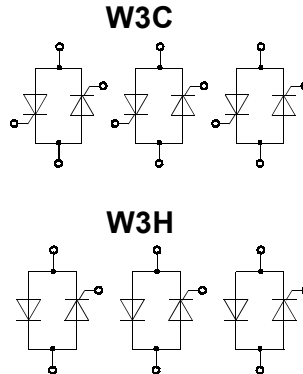

ECO-PAC™ 3

Symbol	Test Conditions	Maximum Ratings
I_{RMS}	$T_C = 85 \text{ }^\circ\text{C}$, 50-400 Hz (per phase)	65 A
I_{TRMS}	$T_{VJ} = T_{VJM}$	47 A
I_{TAVM}	$T_C = 85 \text{ }^\circ\text{C}$; 180° sine, per thyristor	30 A
I_{TSM}	$T_{VJ} = 45 \text{ }^\circ\text{C}$ t = 10 ms (50 Hz), sine	550 A
	$V_R = 0$ t = 8.3 ms (60 Hz), sine	600 A
	$T_{VJ} = 125 \text{ }^\circ\text{C}$ t = 10 ms (50 Hz), sine	490 A
	$V_R = 0$ t = 8.3 ms (60 Hz), sine	540 A
$\int i^2 dt$	$T_{VJ} = 45 \text{ }^\circ\text{C}$ t = 10 ms (50 Hz), sine	1500 A ² s
	$V_R = 0$ t = 8.3 ms (60 Hz), sine	1490 A ² s
	$T_{VJ} = 125 \text{ }^\circ\text{C}$ t = 10 ms (50 Hz), sine	1200 A ² s
	$V_R = 0$ t = 8.3 ms (60 Hz), sine	1210 A ² s
$(di/dt)_{cr}$	$T_{VJ} = 125 \text{ }^\circ\text{C}$ repetitive, $I_T = 50 \text{ A}$ $f=50\text{Hz}$, $t_p=200\mu\text{s}$	150 A/ μs
	$V_D=2/3V_{DRM}$ $I_G=0.3 \text{ A}$ non repetitive, $I_T = I_{TAVM}$ $di_G/dt=0.3\text{A}/\mu\text{s}$	500 A/ μs
$(dv/dt)_{cr}$	$T_{VJ} = 125 \text{ }^\circ\text{C}$ $V_D=2/3V_{DRM}$ $R_{CK} = \infty$, method 1 (linear voltage rise)	1000 V/ μs
P_{GM}	$T_{VJ} = 125 \text{ }^\circ\text{C}$ $t_p=30\mu\text{s}$	$\leq 10 \text{ W}$
	$I_T=I_{TAVM}$ $t_p=300\mu\text{s}$	$\leq 5 \text{ W}$
P_{GAVM}		0.5 W
V_{RGM}		10 V
T_{VJ}		-40... + 125 °C
T_{VJM}		125 °C
T_{stg}		-40... + 125 °C
V_{ISOL}	50/60 Hz, RMS t = 1 min	2500 V~
	$I_{ISOL} \leq 1 \text{ mA}$ t = 1 s	3000 V~
M_d	Mounting torque (M4)	1.5 - 2.0 Nm
		14 - 18 lb.in.
Weight	typ.	46 g

Features

- Thyristor controller for AC (circuit W3C acc. to IEC) for mains frequency □
- Isolation voltage 3000 V~
- Planar glass passivated chips
- Low forward voltage drop
- Leads suitable for PC board soldering
- UL Release applied

Applications

- Switching and control of single and three phase AC circuits
- Light and temperature control
- Softstart AC motor controller
- Solid state switches

Advantages

- Easy to mount with four screws
- Space and weight savings
- Improved temperature and power cycling capability
- High power density
- Small and light weight

Data according to IEC 60747 refer to a single thyristor unless otherwise stated

Symbol	Test Conditions	Characteristic Value
$I_{D'} I_R$	$T_{VJ} = 125^\circ\text{C}$, $V_R = V_{RRM}$, $V_D = V_{DRM}$	≤ 5 mA
V_T	$I_T = 80$ A, $T_{VJ} = 25^\circ\text{C}$	≤ 1.64 V
V_{TO}	For power-loss calculations only	0.85 V
r_T		11 m Ω
V_{GT}	$V_D = 6$ V, $T_{VJ} = 25^\circ\text{C}$	≤ 1.5 V
	$T_{VJ} = -40^\circ\text{C}$	≤ 1.6 V
I_{GT}	$V_D = 6$ V, $T_{VJ} = 25^\circ\text{C}$	≤ 100 mA
	$T_{VJ} = -40^\circ\text{C}$	≤ 200 mA
V_{GD}	$T_{VJ} = 125^\circ\text{C}$, $V_D = 2/3 V_{DRM}$	≤ 0.2 V
I_{GD}	$T_{VJ} = 125^\circ\text{C}$, $V_D = 2/3 V_{DRM}$	≤ 5 mA
I_L	$T_{VJ} = 25^\circ\text{C}$, $t_p = 10\mu\text{s}$, $V_D = 6$ V	≤ 200 mA
	$I_G = 0.3$ A, $di_G/dt = 0.3$ A/ μs	
I_H	$T_{VJ} = 25^\circ\text{C}$, $V_D = 6$ V, $R_{GK} = \infty$	≤ 150 mA
t_{gd}	$T_{VJ} = 25^\circ\text{C}$, $V_D = 1/2 V_{DRM}$	≤ 2 μs
	$I_G = 0.3$ A, $di_G/dt = 0.3$ A/ μs	
t_q	$T_{VJ} = T_{VJM}$; $I_T = 20$ A; $t_p = 200\mu\text{s}$; $di/dt = -10$ A/ μs	150 μs
	$V_R = 100$ V; $dv/dt = 15$ V/ μs ; $V_D = 2/3 V_{DRM}$	
R_{thJC}	per thyristor; DC	0.8 K/W
	per module	0.133 K/W
R_{thJH}	per thyristor; DC	1.1 K/W
	per module	0.183 K/W
d_s	Creepage distance on surface (Pin to heatsink)	11.2 mm
d_A	Strike distance in air (Pin to heatsink)	11.2 mm
a	Max. allowable acceleration	50 m/s ²

Package style and outline

Dimensions in mm (1mm = 0.0394")

W3C

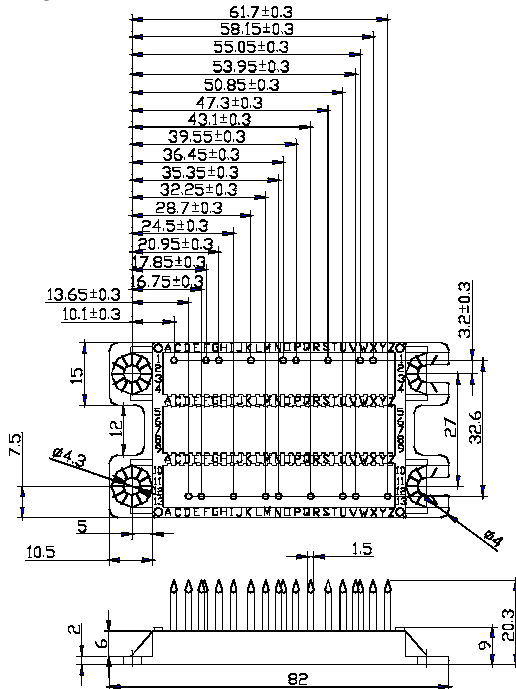

W3H

