

# GLC75 Commercial/GLM75 Medical

## 75 Watt Single Output Global Performance Switchers

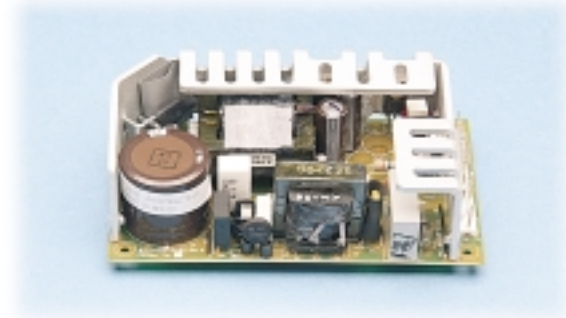

### SPECIFICATIONS:

#### Ac Input

90-264 Vac, 47-63 Hz single phase.

#### Input Current

Maximum input current at 120 Vac, 60 Hz with full rated output load not to exceed 2.3 A.

#### Output Power

Normal continuous output power is 75 W for unrestricted natural convection cooling; 110 W with 26 cfm airflow.

#### Output Regulation

Regulation measured by changing from 5% to 50% load or 50% load to full load in either direction.

#### Overload Protection

Factory set to begin power limiting at approximately 120 W (GLC 75-5 is set at approximately 100 W). Fully protected against short circuit and output overload. Short circuit protection is cycling type power limit.

#### Output Noise

0.5% rms, 1% pk-pk, 20 MHz bandwidth, differential mode. Measured with noise probe directly across output terminals of the power supply.

#### Transient Response

Main Output: 500  $\mu$ s typical response time for return to within 0.5% of final value for a 50% load step change,  $\Delta i/\Delta t < 0.2$  A/ $\mu$ s. Maximum voltage deviation is 3.5%. Startup/shutdown overshoot less than 3%.

#### Overvoltage Protection

Standard on all models.

#### Voltage Adjust

Factory set on standard unit; however, potentiometer adjusts voltage  $\pm 5\%$  minimum. Consult factory for application assistance.

#### Efficiency

72-85% depending on model.

#### Input Protection

Internal ac fuse provided. Designed to blow only if a catastrophic failure occurs in the unit—fuse does not blow on overload or short circuit.

### FEATURES:

- Cost-effective single-output power source
- 3.4" x 5.75" x 1.56" (meets 1U applications)
- Universal input 90-264 Vac
- 2-year warranty
- Complies with EN61000-3-2 Class A
- Also available in multiple output versions
- Conducted EMI exceeds FCC Class B and CISPR 22 Class B (Commercial models) and CISPR 11 Class B (Medical models)
- **Commercial Approved to UL1950, CSA22.2 No. 234 and IEC950, EN60950**
- **Medical Approved to UL2601-1, IEC601-1 and CSA22.2 No. 601**
- **CE** marked to LVD

#### Inrush Current

Inrush limited by internal thermistors. Inrush at 240 Vac, averaged over the first ac half-cycle under cold start conditions will not exceed 37 A.

#### Temperature Coefficient

0.03%/°C typical on all outputs.

#### Power Fail

A standard TTL or CMOS compatible output goes low (< 0.5 V) 5ms before output voltage drops more than 4% below nominal voltage upon loss of ac power. Signal is factory set to trip on 84 to 94 Vac brown-out depending upon incoming line impedance and distortion. Other settings are available through adjustment of built-in potentiometer (consult factory for assistance). Output will stay low for 20 ms minimum.

#### EMI/EMC Compliance

All models include built-in EMI filtering to meet the following emissions requirements:

EMI SPECIFICATIONS	COMPLIANCE LEVEL
Conducted Emissions GLC75	EN55022 Class B; FCC Class B
Conducted Emissions GLM75	EN55011 Class B; FCC Class B
Static Discharge	EN61000-4-2, 6 kV contact, 8 kV air
RF Field Susceptibility	EN61000-4-3, 3 V/meter
Fast Transients/Bursts	EN61000-4-4, 2 kV, 5 kHz
Surge Susceptibility	EN61000-4-5, 1 kV diff., 2 kV com.
Line Frequency Harmonics	EN61000-3-2 Class A

#### Commercial Safety

All GLC models are approved to UL1950, CSA22.2 No. 234 Level 3, IEC950 and EN60950. Consult factory for approval status.

#### Medical Leakage Current

70  $\mu$ A 264 V @ 50 Hz (normal conditions).

#### Medical Safety

All GLM models are approved to UL2601-1, CSA-C22.2 No. 601.1, IEC601-1 and EN60601-1. Consult factory for approval status.



Condor D.C. Power Supplies, Inc., 2311 Statham Parkway, Oxnard, CA 93033  
800-235-5929 • 805-486-4565 • FAX 805-487-8911 • www.condorpower.com

# GLC75 Commercial/GLM75 Medical 75 Watt Single Output

Commercial Model	Medical Model	Output	Output Minimum	Output Maximum (A)	Output Maximum (B)	Output Peak	V1 OVP Set	Noise P-P	Total Regulation
GLC75-5	GLM75-5	5.1 V	0 A	13.7 A	19.6 A	21 A	6.2 ± 0.6 V	50 mV	1%
GLC75-12	GLM75-12	12 V	0 A	6.3 A	9.1 A	9.5 A	15.6 ± 1.1 V	120 mV	1%
GLC75-15	GLM75-15	15 V	0 A	5 A	7.3 A	7.7 A	18.5 ± 1.5 V	150 mV	1%
GLC75-24	GLM75-24	24 V	0 A	3.1 A	4.6 A	5 A	28 ± 2.5 V	240 mV	1%
GLC75-28	GLM75-28	28 V	0 A	2.7 A	4 A	4.4 A	34 ± 2.8 V	280 mV	1%

A. Rating with unrestricted convection cooling. Total power not to exceed 75 W.  
 B. Rating with 26 cfm forced-air cooling. Total power not to exceed 110 W.

## GLC75/GLM75 MECHANICAL SPECIFICATIONS

### INPUT: J1

AMP P/N: 643495-2  
 0.312 CTRS CONNECTOR, 3 CIRCUIT  
 PIN 1 AC GROUND  
 PIN 3 AC NEUTRAL  
 PIN 5 AC LINE

### OUTPUT: J2

AMP P/N: 640445-9  
 0.156 CTR HEADER  

PIN #	SINGLE OUTPUT MODELS
1	OUTPUT #1
2	OUTPUT #1
3	OUTPUT #1
4	OUTPUT #1
5	COMMON
6	COMMON
7	COMMON
8	COMMON
9	POWER FAIL

### MATING CONNECTOR AMP P/N'S

	HOUSING
INPUT:	640250-5
OUTPUT:	640250-9
	CONTACT
INPUT:	770476-1
OUTPUT:	770476-1

NOTE: 5A MAXIMUM RECOMMENDED CURRENT PER CONNECTOR PIN.

WEIGHT: 1.0 LBS. MAX. [0.45 kg]

TOLERANCES: X.XX=0.030 [0.76mm]

X.XXX=0.010 [0.25mm]

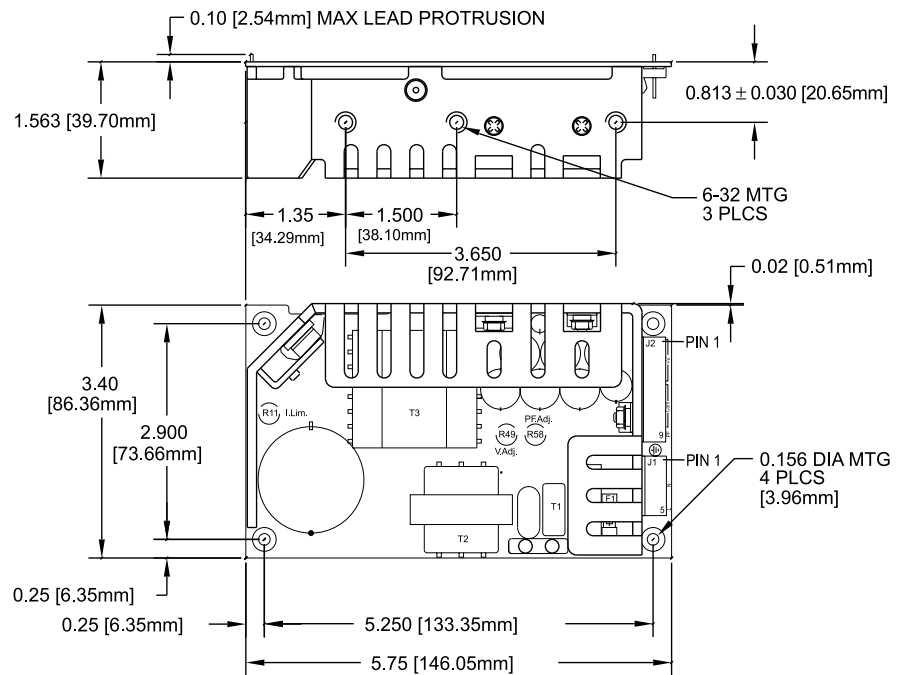

Environmental Specification	Operating	Non-operating
Temperature (A)	0 to 50°C	-40 to +85°C
Humidity (A)	0 to 95% RH	0 to 95% RH
Shock (B)	20 g <sub>pk</sub>	40 g <sub>pk</sub>
Altitude	-500 to 10,000 ft	-500 to 40,000 ft
Vibration (C)	1.5 g <sub>rms</sub> , 0.003 g <sup>2</sup> /Hz	5 g <sub>rms</sub> , 0.026 g <sup>2</sup> /Hz

- A. Units should be allowed to warm up/operate under non-condensing conditions before application of power.
- B. Random vibration—10 to 2000Hz, 6dB/octave roll-off from 350 to 2000Hz, 3 orthogonal axes. Tested for 10 min./axis operating and 1 hr./axis non-operating.
- C. Shock testing—half-sinusoidal, 10 ± 3 ms duration, ± direction, 3 orthogonal axes, total 6 shocks.



Condor D.C. Power Supplies, Inc., 2311 Statham Parkway, Oxnard, CA 93033  
 800-235-5929 • 805-486-4565 • FAX 805-487-8911 • www.condorpower.com