

■ General Description

The AME1505 is a 5A low-dropout positive voltage regulator. The dropout voltage of AME1505 is 750mV at maximum output current. The output voltage is preset at factory. It is available in fixed and adjustable output voltage versions. The fixed voltage range could expand from 1.25V to 3.7V, where 5V and 3.3V voltage supplies are available. AME1505 has 2 new features: First, a remote Sense pin is wired out to eliminate output voltage variation due to load changes. Secondly, an extra Control pin is available to effectively decrease V_{in} to V_o drop. It greatly improves the power dissipation.

Overcurrent and thermal protection are integrated onto the chip. Output current will limit as it reaches the preset current. AME1505 series have excellent regulation over line, load and temperature variations.

■ Features

- Low dropout voltage --- 750mV at 5A
- Adjustable or 1.25~3.7V fixed voltage
- Line regulation 3 mV maximum
- Load regulation 7mV maximum
- Adjust pin (ADJ) current less than 120 μ A
- Dual voltage supplies is recommended
- Overcurrent protection
- Available in TO-220-5, TO-263-5

■ Applications

- VGA Card Supplies
- Post Regulators for Switching Supplies
- Microprocessor Supply
- Chipset Supplies
- LCD Monitor Power

■ Functional Block Diagram

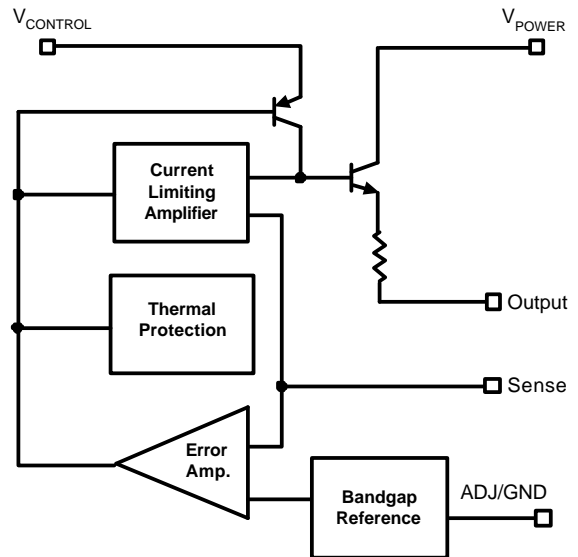

■ Typical Application

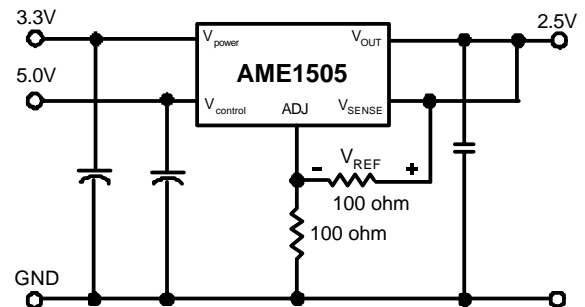

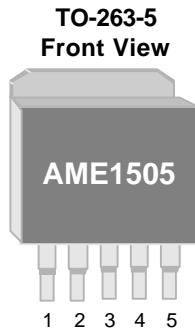
■ Pin Configuration

- AME 1505**
1. SENSE
 2. ADJ / GND
 3. OUTPUT
 4. $V_{CONTROL}$
 5. V_{POWER}

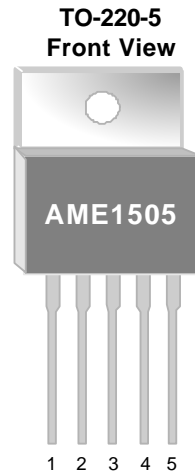

- AME 1505**
1. SENSE
 2. ADJ / GND
 3. OUTPUT
 4. $V_{CONTROL}$
 5. V_{POWER}

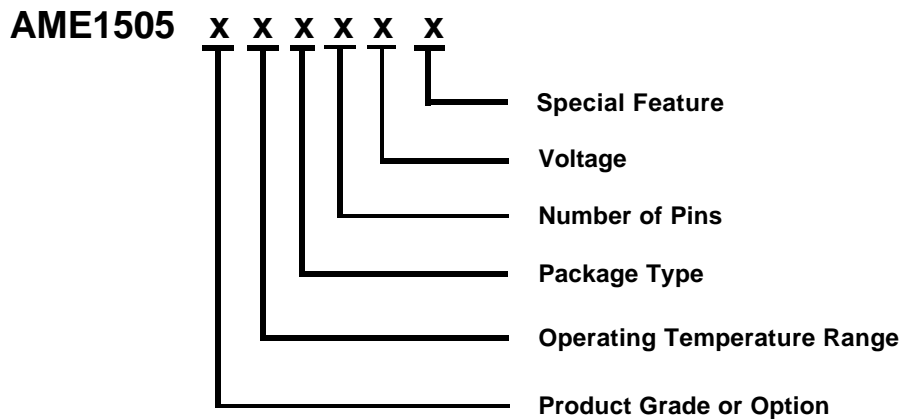
■ Ordering Information

Product Grade or Option	Operating Temperature Range	Package Type	Number of Pins	Voltage	Special Feature
A <small>(TO-263)</small> 1. SENSE 2. ADJ/GND 3. Output 4. $V_{CONTROL}$ 5. V_{POWER}	C: 0°C to 70°C	B: TO-220 D: TO-263	V: 5	ADJ: ADJ 150: 1.5V 250: 2.5V 330: 3.3V	Z: Lead Free
A <small>(TO-220)</small> 1. SENSE 2. ADJ/GND 3. Output 4. $V_{CONTROL}$ 5. V_{POWER}					

■ Ordering Information (contd.)

Part Number	Marking*	Output Voltage	Package	Operating Temp. Range
AME1505ACBVADJ	AME1505 ACBVADJ yyww	ADJ	TO-220-5	0° to 70°C
AME1505ACBVADJZ	AME1505 ACBVADJ yyww	ADJ	TO-220-5	0° to 70°C
AME1505ACBV150	AME1505 ACBV150 yyww	1.5	TO-220-5	0° to 70°C
AME1505ACBV150Z	AME1505 ACBV150 yyww	1.5	TO-220-5	0° to 70°C
AME1505ACBV250	AME1505 ACBV250 yyww	2.5	TO-220-5	0° to 70°C
AME1505ACBV250Z	AME1505 ACBV250 yyww	2.5	TO-220-5	0° to 70°C
AME1505ACBV330	AME1505 ACBV330 yyww	3.3	TO-220-5	0° to 70°C
AME1505ACBV330Z	AME1505 ACBV330 yyww	3.3	TO-220-5	0° to 70°C
AME1505ACDVADJ	AME1505 ACDVADJ yyww	ADJ	TO-263-5	0° to 70°C
AME1505ACDVADJZ	AME1505 ACDVADJ yyww	ADJ	TO-263-5	0° to 70°C
AME1505ACDV150	AME1505 ACDV150 yyww	1.5	TO-263-5	0° to 70°C
AME1505ACDV150Z	AME1505 ACDV150 yyww	1.5	TO-263-5	0° to 70°C

Note: yyww represents the date code

* A line on top of the first letter represents lead free plating such as \bar{A} ME1505

Please consult AME sales office or authorized Rep./Distributor for the availability of output voltage and package type .



■ Absolute Maximum Ratings

Parameter		Symbol	Maximum	Unit
Input Voltage		V_{POWER}	7	V
		$V_{CONTROL}$	13	
Thermal Resistance (Junction to Ambient)	TO-220-5	θ_{JA}	50	°C/W
	TO-263-5		62.5	
Operating Junction Temperature Range		T_J	0 to 125	°C
Storage Temperature Range		T_{STG}	- 65 to 150	
Lead Temperature (10 Sec)		T_{LEAD}	260	

Caution: Stress above the listed absolute maximum rating may cause permanent damage to the device

■ Electrical Specifications

 Electrical Characteristics at $I_o=0\text{mA}$, and $T_j=25^\circ\text{C}$ unless otherwise specified

Parameter	Symbol	Test Condition	Min	Typ	Max	Units
Reference voltage (adjustable voltage)	V_{REF}	$V_{CONTROL} = 2.75\text{V}$, $V_{power}=2\text{V}$, $I_o=10\text{mA}$	1.238	1.250	1.262	V
		$V_{CONTROL} = 2.75 \sim 12\text{V}$, $V_{power}=3.3 \sim 5.5\text{V}$, $I_o=10\text{mA} \sim 5\text{A}$	1.225		1.275	
Output Voltage	1.5V	$V_{CONTROL} = 4\text{V}$, $V_{power}=3.3\text{V}$, $I_o=10\text{mA}$	1.485	1.500	1.515	V
		$V_{CONTROL} = 3\text{V}$, $V_{power}=2.3\text{V}$, $I_o= 10\text{mA} \sim 5\text{A}$	1.470		1.530	
	2.5V	$V_{CONTROL} = 5\text{V}$, $V_{power}=3.3\text{V}$, $I_o=10\text{mA}$	2.475	2.500	2.525	
		$V_{CONTROL} = 4\text{V}$, $V_{power}=3.3\text{V}$, $I_o= 10\text{mA} \sim 5\text{A}$	2.450		2.550	
	3.3V	$V_{CONTROL} = 5.8\text{V}$, $V_{power}=3.8\text{V}$, $I_o=10\text{mA}$	3.267	3.300	3.333	
		$V_{CONTROL} = 4.8\text{V}$, $V_{power}=4.1\text{V}$, $I_o= 10\text{mA} \sim 5\text{A}$	3.234		3.366	
Line regulation	Reg_{LINE}	$I_o=10\text{mA}$, $1.5\text{V} \leq (V_{CONTROL}-V_{OUT}) \leq 12\text{V}$, $0.8\text{V} \leq (V_{POWER}-V_{OUT}) \leq 5.5\text{V}$		1	5	mV
Load regulation	Reg_{LOAD}	$V_{CONTROL} = V_{out} + 2.5\text{V}$, $V_{POWER} = V_{OUT} + 0.8\text{V}$ $I_o=10\text{mA} \sim 5\text{A}$		1	7	mV
Control Dropout ($V_{CONTROL} - V_o$)	V_D	$V_{POWER} = V_o + 0.8\text{V}$, $I_o=5\text{A}$		1.30	1.45	V
Power Dropout ($V_{POWER} - V_o$)		$V_{CONTROL} = V_o + 2.5\text{V}$, $I_o=5\text{A}$		0.45	0.75	
Minimum Load Current (ADJ only)	I_{min}	$V_{CONTROL} = 5\text{V}$, $V_{POWER} = 3.3\text{V}$, $V_{ADJ} = 0\text{V}$		5	10	mA
Control Pin Current		$V_{CONTROL} = V_o + 2.5\text{V}$, $V_{POWER} = V_o + 0.8\text{V}$, $I_o = 10\text{mA} \sim 5\text{A}$		80	100	mA
Ground Pin Current		$V_{CONTROL} = V_o + 2.5\text{V}$, $V_{POWER} = V_o + 0.8\text{V}$, $I_o = 10\text{mA} \sim 5\text{A}$		6	10	mA
ADJ Pin Current		$V_{CONTROL} = 2.75\text{V}$, $V_{POWER} = 2.05\text{V}$, $I_o = 10\text{mA}$		50	120	μA
Current limit	I_S	$V_{IN} - V_o = 5\text{V}$	5.0	7.5	-	A
Temperature Coefficient	T_C	$V_{IN} = 2.75 - 7\text{V}$, $I_o = 10\text{mA} - 5\text{A}$	-	0.005	-	$\%/^\circ\text{C}$
Temperature stability	T_S	$V_{IN} = 5\text{V}$, $I_o = 500\text{mA}$, Over temp.	0.5	0.5	-	%
Ripple rejection ratio	R_A	$V_{CONTROL} = V_{POWER} = V_o + 2.5\text{V}$, $V_{RIPPLE} = 1\text{V}_{P-P}$, $I_o = 2\text{A}$	60	80	-	dB

■ Application Description

1. Output voltage adjustment

Like most regulators, the AME1505 regulates the output by comparing the output voltage to an internally generated reference voltage. On the adjustable version, the V_{REF} is available externally as 1.25V between V_{OUT} and ADJ. The voltage ratio formed by R1 and R2 should be set to conduct 10mA (minimum output load). The output voltage is given by the following equation:

$$V_{OUT} = V_{REF} \left(1 + \frac{R2}{R1} \right) + I_{ADJ} \times R2$$

On fixed versions of AME1505, the voltage divider is factory-preset internally.

2. Current limit protection

AME1505 is protected against overload conditions. Current protection is triggered at typical 7.5A.

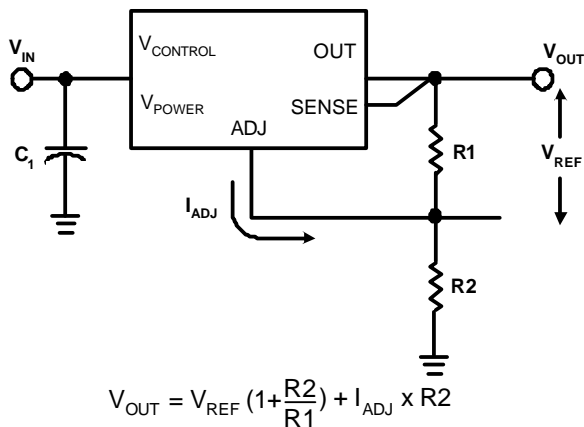

3. Stability and load regulation

AME1505 requires a capacitor from V_{OUT} to GND to provide compensation feedback to the internal gain stage. This is to ensure stability at the output terminal. Typically, a 10 μ F tantalum or 50 μ F aluminum electrolytic is sufficient.

(Note: It is important that the ESR for this capacitor does not exceed 0.5W.)

The output capacitor dose not have a theoretical upper limit and increasing its value will increase stability. $C_{OUT} = 100\mu$ F or more is typical for high current regulator design.

For the adjustable version, the best load regulation is accomplished when the top of the resistor divider (R1) is connected directly to the output pin of the AME1505. When so connected, R_p is not multiplied by the divider ratio.

For fixed output versions, the top of R1 is internally connected to the output. The ground pin can be connected to low side of the load to eliminate ground loop errors.

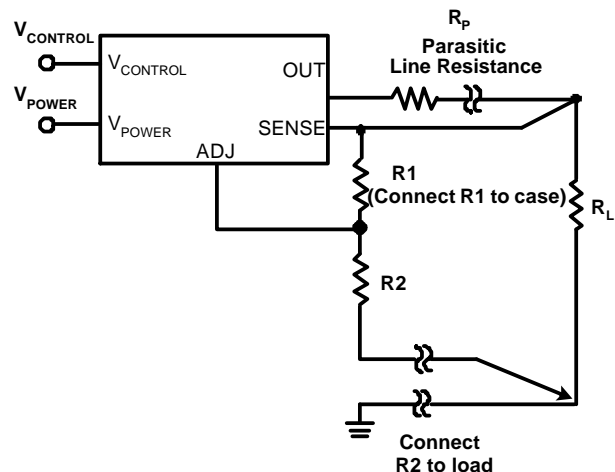

4. Thermal consideration

The AME1505 series contain thermal limiting circuitry designed to protect itself for over-temperature conditions. Even for normal load conditions, maximum junction temperature ratings must not be exceeded. As mention in thermal protection section, we need to consider all sources of thermal resistance between junction and ambient. It includes junction-to-case, case-to-heat-sink interface and heat sink thermal resistance itself.

Junction-to-case thermal resistance is specified from the IC junction to the bottom of the case directly below the die. Proper mounting is required to ensure the best possible thermal flow from this area of the package to the heat sink. The case of all devices in this series is electrically connected to the output. Therefore, if the case of the device must be electrically isolated, a thermally conductive spacer is recommended.

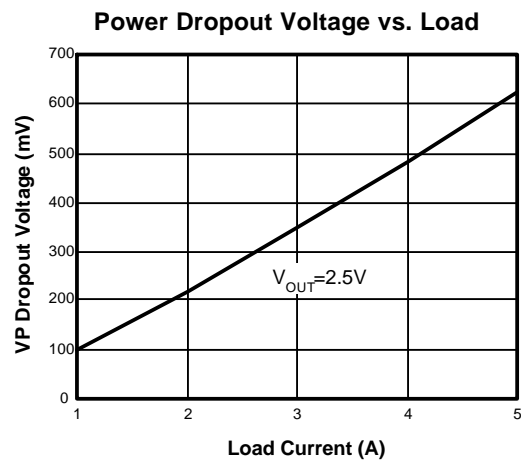
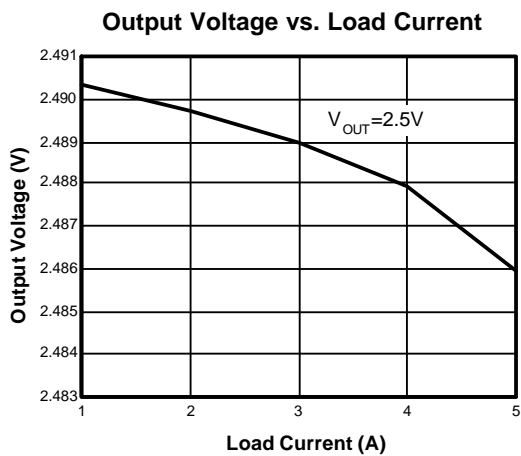
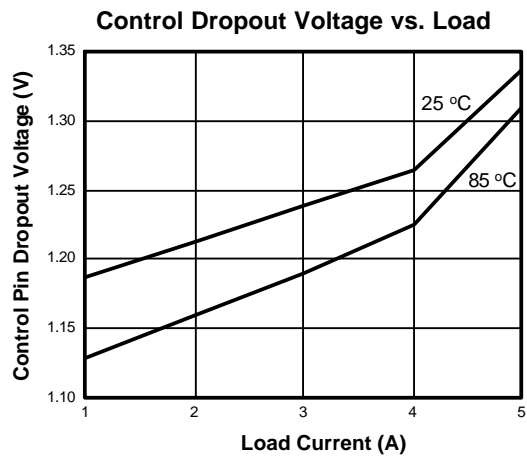
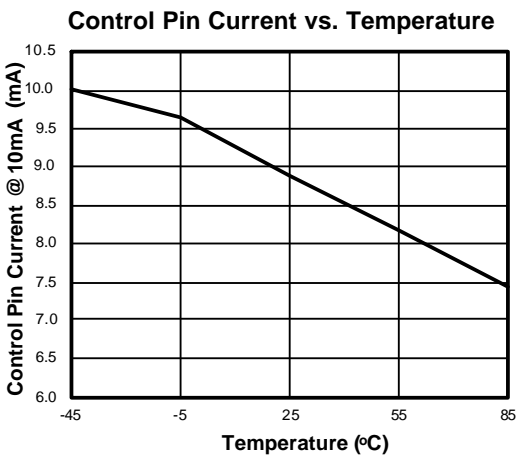
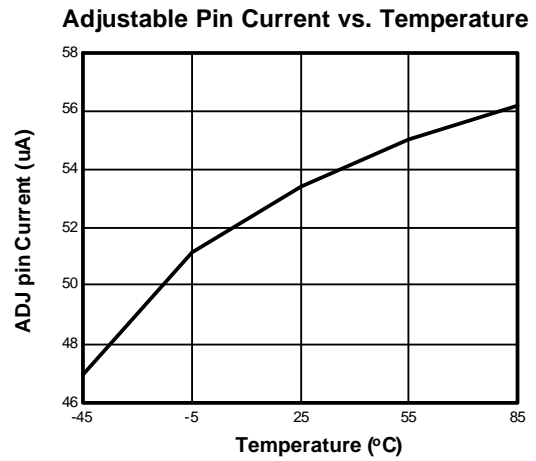
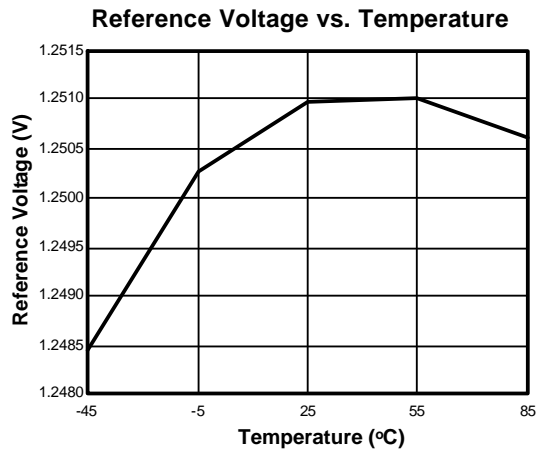

External Resistor Divider Table for Customized Voltage

R1 (Ohm)	100	102	105	107	110	113	115	118	121	124
Vout	R2(Ohm)=(Vout-1.25)*R1/(1.25+50u*R1)									
1.25	0.000	0.000	0.000	0.000	0.000	0.000	0.000	0.000	0.000	0.000
1.30	3.984	4.063	4.182	4.262	4.381	4.500	4.579	4.698	4.817	4.936
1.35	7.968	8.127	8.365	8.524	8.761	8.999	9.158	9.396	9.633	9.871
1.40	11.95	12.19	12.55	12.79	13.14	13.50	13.74	14.09	14.45	14.81
1.45	15.94	16.25	16.73	17.05	17.52	18.00	18.32	18.79	19.27	19.74
1.50	19.92	20.32	20.91	21.31	21.90	22.50	22.89	23.49	24.08	24.68
1.55	23.90	24.38	25.09	25.57	26.28	27.00	27.47	28.19	28.90	29.61
1.60	27.89	28.44	29.28	29.83	30.67	31.50	32.05	32.88	33.72	34.55
1.65	31.87	32.51	33.46	34.09	35.05	36.00	36.63	37.58	38.53	39.48
1.70	35.86	36.57	37.64	38.36	39.43	40.50	41.21	42.28	43.35	44.42
1.75	39.84	40.63	41.82	42.62	43.81	45.00	45.79	46.98	48.17	49.36
1.80	43.82	44.70	46.01	46.88	48.19	49.50	50.37	51.68	52.98	54.29
1.85	47.81	48.76	50.19	51.14	52.57	54.00	54.95	56.37	57.80	59.23
1.90	51.79	52.82	54.37	55.40	56.95	58.50	59.53	61.07	62.62	64.16
1.95	55.78	56.89	58.55	59.66	61.33	63.00	64.11	65.77	67.43	69.10
2.00	59.76	60.95	62.74	63.93	65.71	67.49	68.68	70.47	72.25	74.03
2.05	63.75	65.01	66.92	68.19	70.09	71.99	73.26	75.17	77.07	78.97
2.10	67.73	69.08	71.10	72.45	74.47	76.49	77.84	79.86	81.88	83.90
2.15	71.71	73.14	75.28	76.71	78.85	80.99	82.42	84.56	86.70	88.84
2.20	75.70	77.21	79.47	80.97	83.23	85.49	87.00	89.26	91.52	93.77
2.25	79.68	81.27	83.65	85.24	87.61	89.99	91.58	93.96	96.33	98.71
2.30	83.67	85.33	87.83	89.50	92.00	94.49	96.16	98.65	101.2	103.6
2.35	87.65	89.40	92.01	93.76	96.38	98.99	100.7	103.4	106.0	108.6
2.40	91.63	93.46	96.20	98.02	100.8	103.5	105.3	108.1	110.8	113.5
2.45	95.62	97.52	100.4	102.3	105.1	108.0	109.9	112.7	115.6	118.5
2.50	99.60	101.6	104.6	106.5	109.5	112.5	114.5	117.4	120.4	123.4
2.55	103.6	105.6	108.7	110.8	113.9	117.0	119.1	122.1	125.2	128.3
2.60	107.6	109.7	112.9	115.1	118.3	121.5	123.6	126.8	130.1	133.3
2.65	111.6	113.8	117.1	119.3	122.7	126.0	128.2	131.5	134.9	138.2
2.70	115.5	117.8	121.3	123.6	127.0	130.5	132.8	136.2	139.7	143.1
2.75	119.5	121.9	125.5	127.9	131.4	135.0	137.4	140.9	144.5	148.1
2.80	123.5	126.0	129.7	132.1	135.8	139.5	141.9	145.6	149.3	153.0
2.85	127.5	130.0	133.8	136.4	140.2	144.0	146.5	150.3	154.1	157.9
2.90	131.5	134.1	138.0	140.6	144.6	148.5	151.1	155.0	159.0	162.9
2.95	135.5	138.2	142.2	144.9	148.9	153.0	155.7	159.7	163.8	167.8
3.00	139.4	142.2	146.4	149.2	153.3	157.5	160.3	164.4	168.6	172.7
3.05	143.4	146.3	150.6	153.4	157.7	162.0	164.8	169.1	173.4	177.7
3.10	147.4	150.3	154.8	157.7	162.1	166.5	169.4	173.8	178.2	182.6

External Resistor Divider Table for Customized Voltage (contd.)

R1 (Ohm)	100	102	105	107	110	113	115	118	121	124
Vout	R2(Ohm)=(Vout-1.25)*R1/(1.25+50u*R1)									
3.15	151.4	154.4	158.9	161.9	166.5	171.0	174.0	178.5	183.0	187.5
3.20	155.4	158.5	163.1	166.2	170.8	175.5	178.6	183.2	187.9	192.5
3.25	159.4	162.5	167.3	170.5	175.2	180.0	183.2	187.9	192.7	197.4
3.30	163.3	166.6	171.5	174.7	179.6	184.5	187.7	192.6	197.5	202.4
3.35	167.3	170.7	175.7	179.0	184.0	189.0	192.3	197.3	202.3	207.3
3.40	171.3	174.7	179.8	183.3	188.4	193.5	196.9	202.0	207.1	212.2
3.45	175.3	178.8	184.0	187.5	192.8	198.0	201.5	206.7	211.9	217.2
3.50	179.3	182.9	188.2	191.8	197.1	202.5	206.1	211.4	216.8	222.1
3.55	183.3	186.9	192.4	196.0	201.5	207.0	210.6	216.1	221.6	227.0
3.60	187.3	191.0	196.6	200.3	205.9	211.5	215.2	220.8	226.4	232.0
3.65	191.2	195.0	200.8	204.6	210.3	216.0	219.8	225.5	231.2	236.9
3.70	195.2	199.1	204.9	208.8	214.7	220.5	224.4	230.2	236.0	241.8
3.75	199.2	203.2	209.1	213.1	219.0	225.0	228.9	234.9	240.8	246.8
3.80	203.2	207.2	213.3	217.3	223.4	229.5	233.5	239.6	245.7	251.7
3.85	207.2	211.3	217.5	221.6	227.8	234.0	238.1	244.3	250.5	256.6
3.90	211.2	215.4	221.7	225.9	232.2	238.5	242.7	249.0	255.3	261.6
3.95	215.1	219.4	225.9	230.1	236.6	243.0	247.3	253.7	260.1	266.5
4.00	219.1	223.5	230.0	234.4	240.9	247.5	251.8	258.4	264.9	271.5
4.05	223.1	227.6	234.2	238.7	245.3	252.0	256.4	263.1	269.7	276.4
4.10	227.1	231.6	238.4	242.9	249.7	256.5	261.0	267.8	274.6	281.3
4.15	231.1	235.7	242.6	247.2	254.1	261.0	265.6	272.5	279.4	286.3
4.20	235.1	239.7	246.8	251.4	258.5	265.5	270.2	277.2	284.2	291.2
4.25	239.0	243.8	250.9	255.7	262.8	270.0	274.7	281.9	289.0	296.1
4.30	243.0	247.9	255.1	260.0	267.2	274.5	279.3	286.6	293.8	301.1
4.35	247.0	251.9	259.3	264.2	271.6	279.0	283.9	291.3	298.6	306.0
4.40	251.0	256.0	263.5	268.5	276.0	283.5	288.5	296.0	303.5	310.9
4.45	255.0	260.1	267.7	272.8	280.4	288.0	293.1	300.7	308.3	315.9
4.50	259.0	264.1	271.9	277.0	284.7	292.5	297.6	305.4	313.1	320.8
4.55	262.9	268.2	276.0	281.3	289.1	297.0	302.2	310.1	317.9	325.7
4.60	266.9	272.2	280.2	285.5	293.5	301.5	306.8	314.8	322.7	330.7
4.65	270.9	276.3	284.4	289.8	297.9	306.0	311.4	319.5	327.5	335.6
4.70	274.9	280.4	288.6	294.1	302.3	310.5	315.9	324.2	332.4	340.6
4.75	278.9	284.4	292.8	298.3	306.7	315.0	320.5	328.8	337.2	345.5
4.80	282.9	288.5	297.0	302.6	311.0	319.5	325.1	333.5	342.0	350.4
4.85	286.9	292.6	301.1	306.8	315.4	324.0	329.7	338.2	346.8	355.4
4.90	290.8	296.6	305.3	311.1	319.8	328.5	334.3	342.9	351.6	360.3
4.95	294.8	300.7	309.5	315.4	324.2	333.0	338.8	347.6	356.4	365.2
5.00	298.8	304.8	313.7	319.6	328.6	337.5	343.4	352.3	361.3	370.2

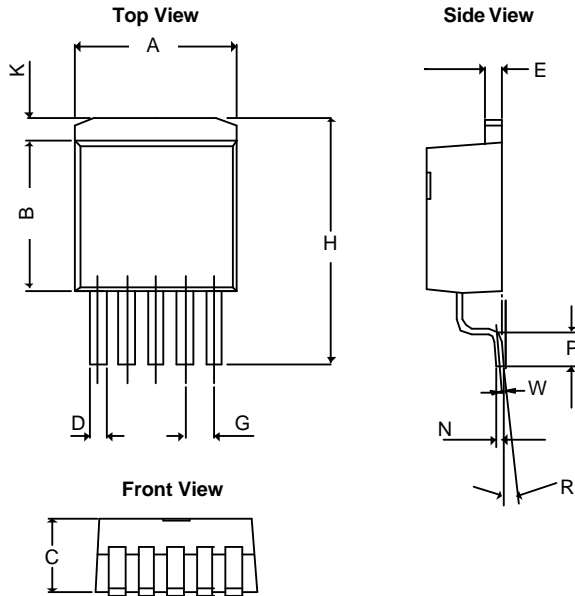
■ Package Dimension
TO-263-5

SYMBOLS	MILLIMETERS		INCHES	
	MIN	MAX	MIN	MAX
A	10.050	10.668	0.396	0.420
B	8.280	9.169	0.326	0.361
C	4.310	4.670	0.170	0.184
D	0.660	0.910	0.026	0.036
E	1.140	1.400	0.045	0.055
G	1.70REF		0.067 REF	
H	14.605	15.875	0.575	0.625
K	1.143	1.680	0.045	0.066
N	0.330	0.580	0.013	0.023
P	2.280	2.800	0.090	0.110
R	0°	8°	0°	8°
W	0.25REF		0.01REF	

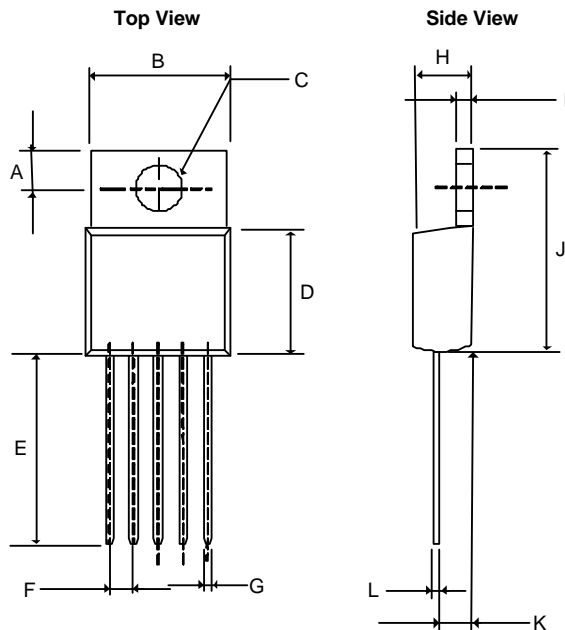
TO-220-5

SYMBOLS	MILLIMETERS		INCHES	
	MIN	MAX	MIN	MAX
A	2.616	2.870	0.103	0.113
B	REF	REF	REF	REF
C	10.160	10.668	0.400	0.420
D	3.708	3.962	0.146	0.156
E	8.915	9.169	0.351	0.361
F	12.700	14.732	0.500	0.580
G	1.575	1.829	0.062	0.072
H	0.711	0.965	0.028	0.038
I	4.343	4.597	0.171	0.181
J	1.143	1.397	0.045	0.055
K	14.859	15.113	0.585	0.595
L	2.032	3.048	0.080	0.120
L	0.305	0.457	0.012	0.018



www.ame.com.tw
E-Mail: sales@ame.com.tw

Life Support Policy:

These products of AME, Inc. are not authorized for use as critical components in life-support devices or systems, without the express written approval of the president of AME, Inc.

AME, Inc. reserves the right to make changes in the circuitry and specifications of its devices and advises its customers to obtain the latest version of relevant information.

© AME, Inc. , June 2005
Document: 2039-DS1505-J

Corporate Headquarter
AME, Inc.

2F, 302 Rui-Guang Road, Nei-Hu District
Taipei 114, Taiwan.
Tel: 886 2 2627-8687
Fax: 886 2 2659-2989

U.S.A.(Subsidiary)
Analog Microelectronics, Inc.

3100 De La Cruz Blvd., Suite 201
Santa Clara, CA. 95054-2046
Tel : (408) 988-2388
Fax: (408) 988-2489