

RC5037

Adjustable Switching Regulator Controller

Features

- High power switch-mode DC-DC controller can provide in excess of 13A
- Output voltage adjustable from 1.5V to 3.6V
- 85% efficiency
- Cumulative accuracy < 3% over line, load, and temperature variations
- Overvoltage and short circuit protection
- Built-in soft start

Applications

- I/O and AGP power for desktop computers
- High efficiency power for ASICs
- High efficiency power for DSPs
- Adjustable step-down power supplies

Description

The RC5037 is a high power, switch-mode DC-DC controller that provides efficient power for all low-voltage applications. This controller has a built-in Soft Start feature which offers system protection during power-up by reducing both inrush current and output overshoot. When combined with the appropriate external circuitry, the RC5037 can deliver load currents as high as 13A at efficiencies as high as 88%. The RC5037 can generate output voltages from 1.5V up to 3.6V using external resistors.

The RC5037 is designed to operate in a constant on-time control mode under all load conditions. Its accurate low TC reference eliminates the need for precision external components in order to achieve the tight tolerance voltage regulation required by many applications. Short circuit current protection is provided through the use of a current sense resistor, while overvoltage protection is provided internally.

Block Diagram

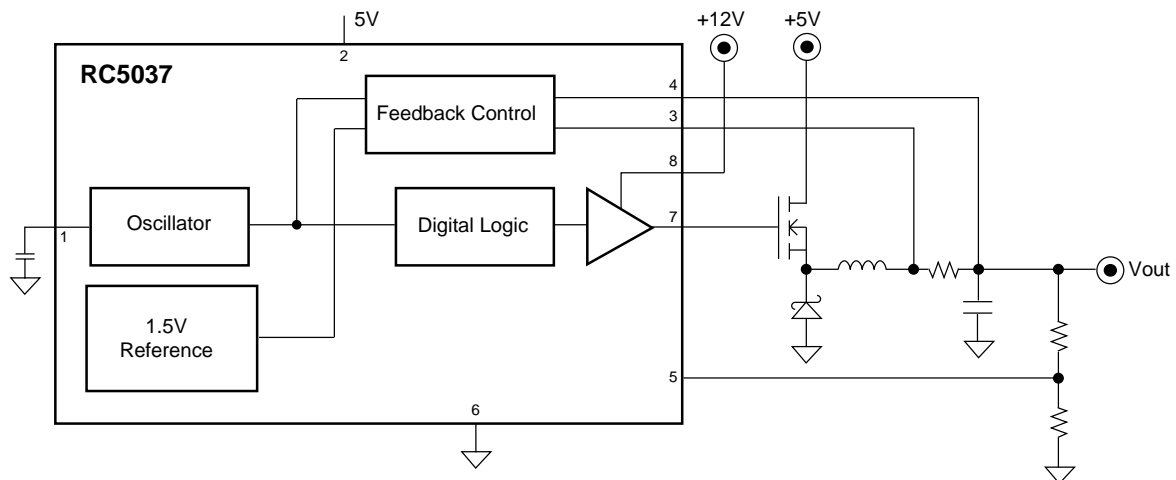

Pin Assignments

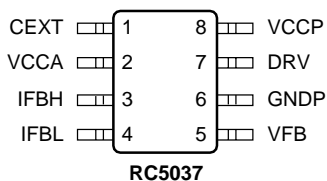

Pin Descriptions

Pin Name	Pin Number	Pin Function Description
CEXT	1	External capacitor. A 180pF capacitor is connected to this pin as part of the constant on-time pulse width circuit. Careful layout of this pin is critical to system performance. See Applications Information for details.
VCCA	2	Analog V_{cc}. Power supply for regulator control circuitry and voltage reference. Connect to system 5V supply and decouple to ground with 0.1μF ceramic capacitor.
IFBH	3	High side current feedback. Pins 3 and 4 are used as the inputs for the current feedback control loop and as the short circuit current sense points. Careful layout of the traces from these pins to the current sense resistor is critical for optimal performance of the short circuit protection scheme. See Applications Information for details.
IFBL	4	Low side current feedback. See Applications Information for details.
VFB	5	Voltage feedback. Using two external resistors, this pin sets the output voltage level for the switching regulator.
GNDP	6	Power Ground. Connect to a low impedance ground. See Application Information for details.
DRV	7	MOSFET driver output. Connect this pin to the gate of the N-channel MOSFET Q1 as shown in Figure 12. The trace from this pin to the MOSFET gate should be kept as short as possible (less than 0.5"). See Applications Information for details.
VCCP	8	Power V_{cc}. Power supply for DRV output driver. Connect to system 12V supply with R-C filter shown in Figure 12. See Applications Information for details.

Absolute Maximum Ratings

Supply Voltages, VCCA	7V
Supply Voltages, VCCP	13V
Junction Temperature, T _J	+150° C
Storage Temperature, T _S	-65 to +150° C
Lead Soldering Temperature, 10 seconds	300° C
Thermal Resistance Junction-to-Ambient, θ _{JA}	163°C/W

Note:

- Functional operation under any of these conditions is not implied. Performance is guaranteed only if Operating Conditions are not exceeded.

Operating Conditions

Parameter	Conditions	Min.	Typ.	Max.	Units
Switching Regulator Supply, VCCA		4.75	5	5.25	V
Ambient Operating Temperature, T _A		0		70	°C
Gate Drive Supply, VCCP		9.5	12	12.6	V

Electrical Characteristics

(VCCA = 5V, VCCP = 12V, T_A = 25°C using circuit of Figure 1, unless otherwise noted)

The • denotes specifications which apply over the full ambient operating temperature range.

Parameter	Conditions	Min.	Typ.	Max.	Units	
Output Voltage		1.5		3.6	V	
Output Temperature Drift	T _A = 0°C–70°C		40		ppm/°C	
Line Regulation	VCCA = 4.75 to 5.25V, I _{LOAD} = 13A		3	5	mV	
Load Regulation	I _{LOAD} = 0 to 5A or 5A to 13A		30	43	mV	
V _{OUT} PSRR	VCCA = 4.75 to 5.25V	60			dB	
Output Ripple, peak-peak	20MHz BW, I _{LOAD} = 13A		15		mV	
Total DC Accuracy ¹		•	±55	±100	mV	
Efficiency	I _{LOAD} = 5A	80	85		%	
Output Driver Current	Open Loop	•	0.5		A	
Short Circuit Threshold Voltage		•	70	90	100	mV
On Time Pulse Width ²	C _{EXT} = 180pF		3.5		µs	
VCCA Supply Current	Independent of load	•	5	15	mA	
VCCP Supply Current	I _{LOAD} = 13A	•	20	25	mA	

Notes:

1. Total DC accuracy includes setpoint accuracy, temperature drift, line and load regulation.
2. The on-time pulse width of the oscillator is set via external capacitor C_{EXT}.

Typical Operating Characteristics

(VCCA = 5V, and TA = +25°C using circuit in Figure 1, unless otherwise noted)

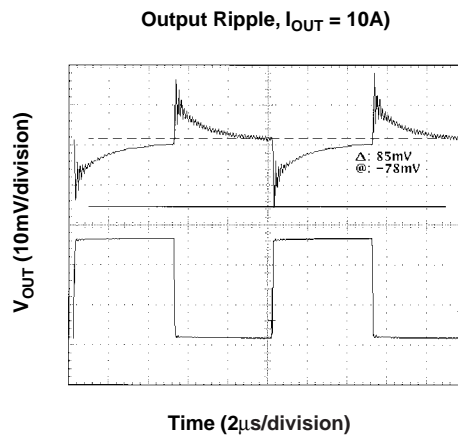
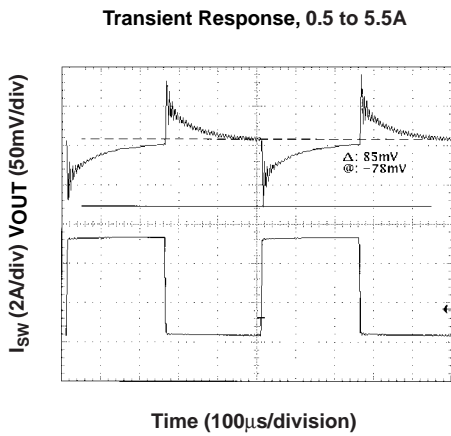
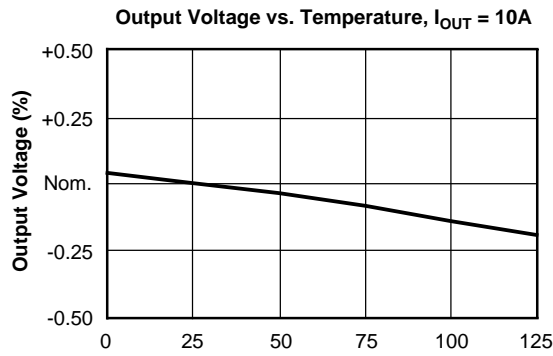
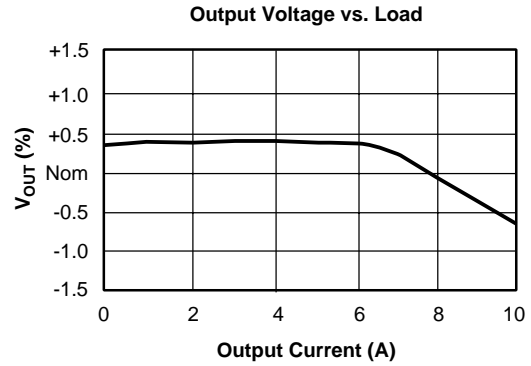
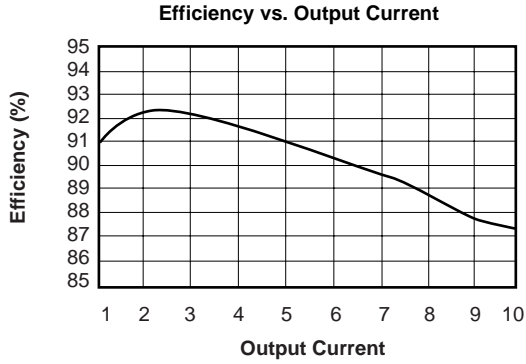

Typical Operating Characteristics (continued)

Output Startup, System Power-Up

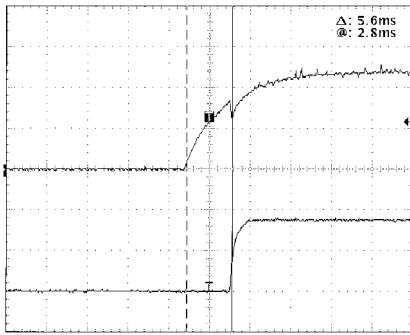

Time (5ms/division)

Pin 7 (DRV), 10A Load

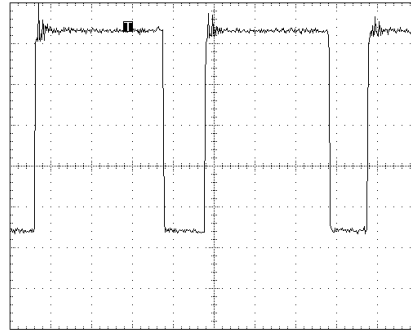

Time (1µs/division)

Pin 7 (DRV), 0.1A Load

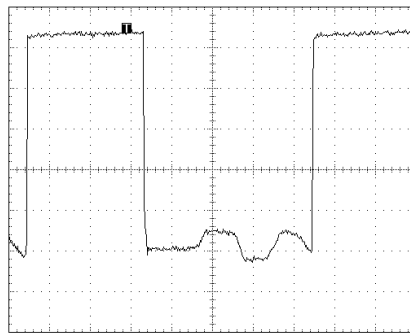

Time (1µs/division)

Application Circuit

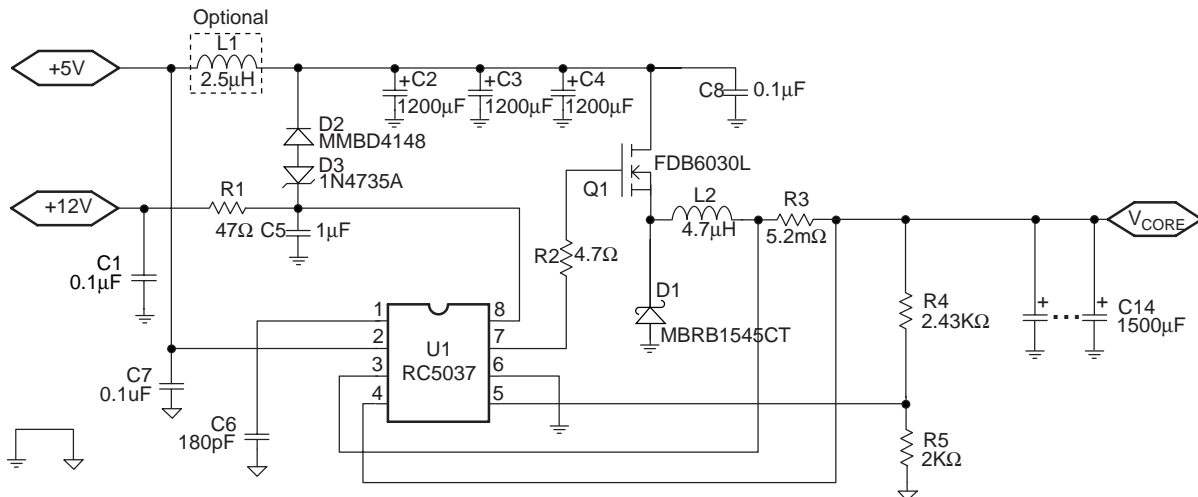

Figure 1. 13A at 3.3V Application Schematic

Table1. Bill of Materials for a RC5037 3.3V, 13A Application

Qty.	Reference	Manufacturer Part Order #	Description	Requirements and Comments
3	C1, C7-8	Any	100nF, 25V Capacitor	
3	C2-4	Sanyo 10MV1200GX	1200 μ F, 10V Aluminum Capacitor	IRMS = 2A , See Equation (2) in Applications
1	C5	Any	1 μ F, 25V Capacitor	
1	C6	Any	180pF, 50V Capacitor	C0G
6	C9-14	Sanyo 6MV1500GX	1500 μ F, 6.3V Aluminum Capacitor	ESR = 44m Ω
1	R1	Any	47.5 Ω	
1	R2	Any	4.75 Ω	
1	R3	N/A	5.2m Ω , 1W Resistor	PCB Trace Resistor, see Equation (3) Applications
1	R4	Any	2.43K Ω	
1	R5	Any	2K Ω	
1	D1	Motorola MBRB1545CT	15A, 45V Schottky	
1	D2	Fairchild MMBD4148	Signal Diode	
1	D3	Motorola 1N4735A	6.2V Zener	
1	Q1	Fairchild FDB6030L	30V, 14m Ω Logic Level MOSFET	
Optional	L1	Any	2.5 μ H Inductor	ISAT > 8A
1	L2	Any	4.7 μ H Inductor	ISAT > 13A
1	U1	Fairchild RC5037M	PWM Controller	

Application Information

The RC5037 contains a precision trimmed zero TC voltage reference, a constant-on-time architecture controller, a high current output driver, and a low offset error amp. The detailed block diagram in Figure 1 shows how the RC5037 works together with external components to achieve a high-performance switching power supply.

Switch-Mode Control Loop

The main control loop for the switch-mode converter consists of a current conditioning amplifier and a voltage conditioning amplifier. The voltage amplifier compares the voltage from the internal reference with the converter's output voltage divided by an external resistor divider. The current amplifier senses the current by comparing the voltages at the IFBH and IFBL pins, which are attached to either side of the current sense resistor. The signals from the voltage and current amplifiers are summed together, the result being used to control the off-time of the oscillator. The current feedback signal is also used as part of the RC5037 short-circuit protection.

High Current Output Drivers

The RC5037 high current output driver (DRV) contains high speed bipolar power transistors configured in a push-pull configuration. The output driver is capable of supplying 0.5A of current in less than 100ns. The driver's power and ground are separated from the overall chip power and ground for added switching noise immunity.

Internal Reference

The reference in the RC5037 is a precision band-gap type reference. Its temperature coefficient is trimmed to provide a near zero TC.

Constant-On-Time Oscillator

The RC5037 switch-mode oscillator is designed as a fixed on-time, variable off-time oscillator. The constant-on-time oscillator consists of a comparator, an external capacitor, a fixed current source, a variable current source, and an analog switch that selects between two threshold voltages for the comparator. The external timing capacitor is alternately

charged and discharged through the enabling and disabling of the fixed current source. The variable current source is controlled from the error inputs that are received from the current and voltage feedback signals. The oscillator off-time is controlled by the amount of current that is available from

the variable current source to charge the external capacitor up to the high threshold level of the comparator. The on-time is set by the constant current source that discharges the external capacitor voltage down to the lower comparator threshold.

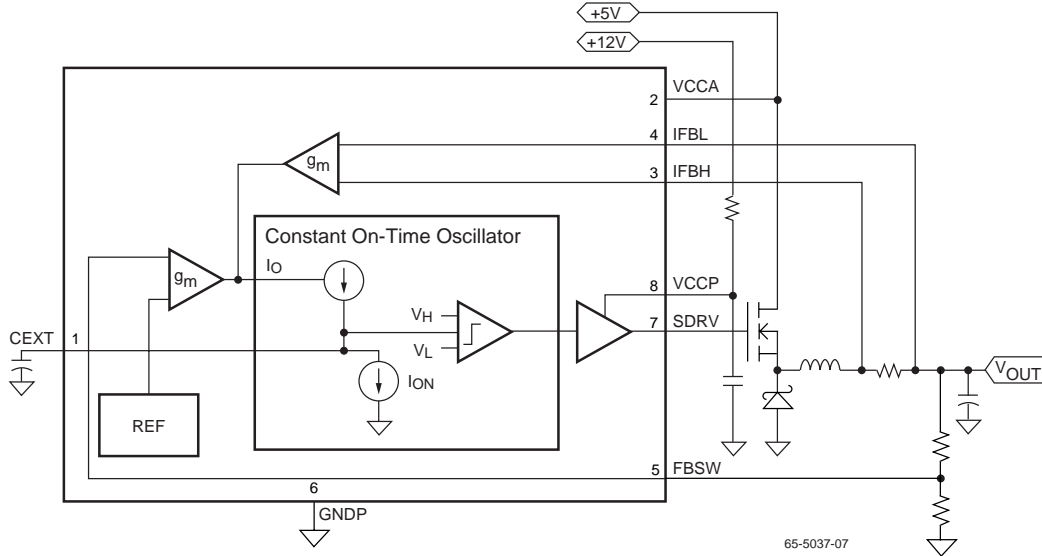

Figure 2. RC5037 Detailed Block Diagram

Output Voltage Selection

The RC5037 precision reference is trimmed to be 1.5V nominally. When using the RC5037, the system designer has complete flexibility in choosing the output voltage for one regulator from 1.5V to 3.6V. This is done by appropriately selecting the feedback resistors. These could be 0.1% resistors to realize optimum output accuracy. The following equations determines the output voltage of the regulator:

$$V_{OUT} = 1.5 \times \left(\frac{R4 + R5}{R5} \right) \tag{1}$$

For example, for 3.3V:

$$V_{OUT} = 1.5 \times \left(\frac{R4 + R5}{R5} \right) = 1.5 \times \left(\frac{2.43k + 2.0k}{2.0k} \right) = 3.3V$$

Input Capacitors

The number of input capacitors required for the RC5037 is dependent on their ripple current rating, which assures their rated life. The number required may be determined by

$$\text{No. Caps} = \frac{I_{out} \sqrt{DC - DC^2}}{I_{rating}} \tag{2}$$

where the duty cycle $DC = V_{out}/V_{in}$. For example, with a 1.5V output at 10A, 5V input, and using the Sanyo capacitors specified in Table 1 which have a 2A ripple current rat-

ing, we have $DC = 1.5/5 = 0.3$, and

$$\text{No. Caps} = \frac{10 \sqrt{0.03 - 0.3^2}}{2} = 2.29$$

so that we need 3 input capacitors.

Short Circuit Considerations

The RC5037 uses a current sensing scheme to limit the load current if an output fault condition occurs. The current sense resistor carries the peak current of the inductor, which is greater than the maximum load current due to ripple current flowing in the inductor. The RC5037 will begin to limit the output current to the load by reducing the duty cycle of the top-side MOSFET driver when the voltage across the current-sense resistor exceeds the short circuit comparator threshold voltage (V_{th}). When this happens the output voltage will temporarily go out of regulation. As the voltage across the sense resistor becomes larger, the duty cycle of the top-side MOSFET will continue to be reduced until the current limit value is reached. At this point, the RC5037 will continuously deliver the limit current at a reduced output voltage level. The short circuit comparator threshold voltage is typically 90mV, with a tolerance of $\pm 10mV$. The ripple current flowing through the inductor in Figure 1 is 0.6A. Refer to Application Note AM-53 for detailed discussions. The sense resistor value can be approximated as follows:

$$R_{SENSE} = \frac{V_{th,min}}{I_{PK}} \times (1 - TF) = \frac{V_{th,min}}{0.6A + I_{LOAD,MAX}} \times (1 - TF) \tag{3}$$

where TF = Tolerance Factor for the sense resistor and 0.6A accounts for the inductor ripple current.

Since the value of the sense resistor is often less than 10mΩ, care should be taken in the layout of the PCB. Trace resistance can contribute significant errors. The traces to the IFBH and IFBL pins of the RC5037 should be Kelvin connected to the pads of the current-sense resistor. To minimize the influence of noise, the two traces should be run next to each other.

Schottky Diode

In Figure 1, MOSFET Q1 and flyback diode D1 are used as complementary switches in order to maintain a constant current through the output inductor L2. As a result, D1 will have to carry the full current of the output load when the power MOSFET is turned off. The power in the diode is a direct function of the forward voltage at the rated load current during the off time of the FET. The following equation can be used to estimate the diode power:

$$P_{\text{DIODE}} = I_D \times V_D \times (1 - \text{DutyCycle})$$

where I_D is the forward current of the diode, V_D is the forward voltage of the diode, and DutyCycle is defined the same as

$$\text{Duty Cycle} = \frac{V_{\text{out}}}{V_{\text{in}}}$$

For the Motorola MBRB1545CT Rectifier in Figure 1,

$$P_{\text{DIODE}} = 10\text{A} \times 0.65 \times (1 - 73.1\%) = 1.75\text{W}$$

It is recommended that the diode T0-220 package be attached to a heatsink.

Board Design Considerations

MOSFET Placement

Placement of the power MOSFET is critical in the design of the switch-mode regulator. The MOSFET should be placed in such a way as to minimize the length of the gate drive path from the RC5037 SDRV pin. This trace should be kept under 0.5" for optimal performance. Excessive lead length on this trace will cause high frequency noise resulting from the parasitic inductance and capacitance of the trace. Since this voltage can transition nearly 12V in around 100nsec, the resultant ringing and noise would be very difficult to suppress. This trace should be routed on one layer only and kept well away from the "quiet" analog pins of the device: CEXT, IFBH, IFBL, and GND. Refer to Figure 2. A 4.7Ω resistor in series with the MOSFET gate can decrease this layout criticality. Refer to Figure 1.

Inductor and Schottky Diode Placement

The inductor and fly-back Schottky diode need to be placed close to the source of the power MOSFET for the same reasons stated above. The node connecting the inductor and Schottky diode will swing between the drain voltage of the FET and the forward voltage of the Schottky diode. It is recommended that this node be converted to a plane if possible. This node will be part of the high current path in the design, and as such it is best treated as a plane in order to minimize the parasitic resistance and inductance on that node. Since most PC board manufacturers utilize 1/2 oz copper on the top and bottom signal layers of the PCB, it is not recommended to use these layers to route the high current portions of the regulator design. Since it is more common to use 1 oz. copper on the PCB inner layers, it is recommended to use those layers to route the high current paths in the design.

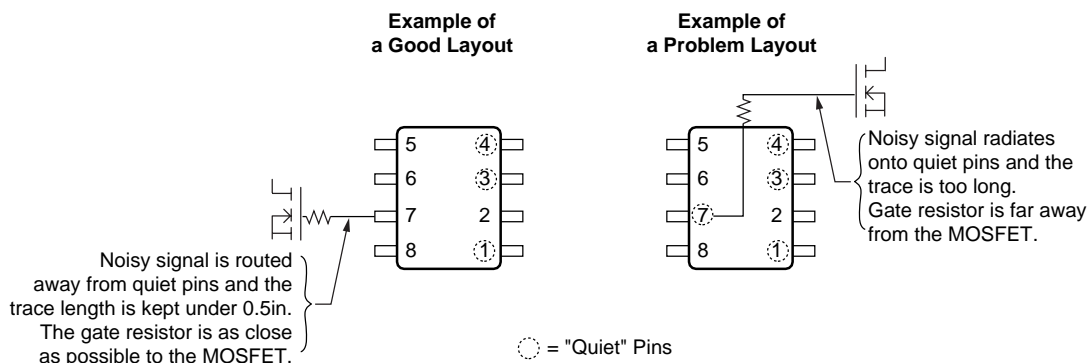

Figure 3. Examples of good and poor layouts

Power and Ground Connections

The connection of VCCA to the 5V power supply plane should be short and bypassed with a $0.1\mu\text{F}$ directly at the VCCA pin of the RC5037. The ideal connection would be a via down to the 5V power plane. A similar arrangement should be made for the VCCP pin that connects to +12V. Each ground should have a separate via connection to the ground plane below.

A 12V power supply is used to bias the VCCP. A 47Ω resistor is used to limit the transient current into VCCP. A $1\mu\text{F}$ capacitor filter is used to filter the VCCP supply and source the transient current required to charge the MOSFET gate capacitance. This method provides sufficiently high gate bias voltage to the MOSFET (V_{GS}), and therefore reduces $R_{DS(ON)}$ of the MOSFET and its power loss.

Figure 4 provides about 5V of gate bias which works well when using typical logic-level MOSFETs. Non-logic-level MOSFETs should not be used because of their higher $R_{DS(ON)}$.

MOSFET Gate Bias

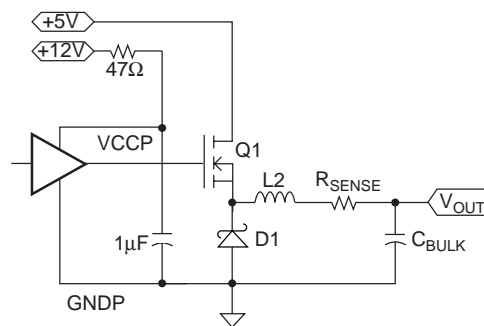

Figure 4. 12V Gate Bias Configuration

Mechanical Dimensions

8 Lead SOIC Package

Symbol	Inches		Millimeters		Notes
	Min.	Max.	Min.	Max.	
A	.053	.069	1.35	1.75	
A1	.004	.010	0.10	0.25	
B	.013	.020	0.33	0.51	
C	.008	.010	0.20	0.25	5
D	.189	.197	4.80	5.00	2
E	.150	.158	3.81	4.01	2
e	.050 BSC		1.27 BSC		
H	.228	.244	5.79	6.20	
h	.010	.020	0.25	0.50	
L	.016	.050	0.40	1.27	3
N	8		8		6
α	0°	8°	0°	8°	
ccc	—	.004	—	0.10	

Notes:

1. Dimensioning and tolerancing per ANSI Y14.5M-1982.
2. "D" and "E" do not include mold flash. Mold flash or protrusions shall not exceed .010 inch (0.25mm).
3. "L" is the length of terminal for soldering to a substrate.
4. Terminal numbers are shown for reference only.
5. "C" dimension does not include solder finish thickness.
6. Symbol "N" is the maximum number of terminals.

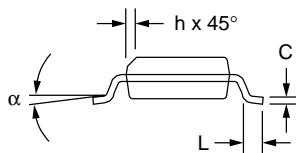
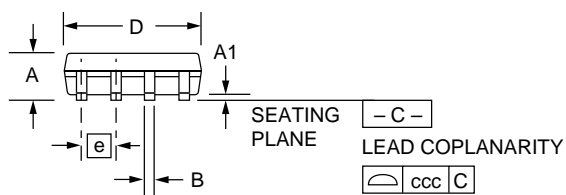
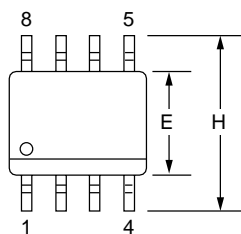

Ordering Information

Product Number	Package
RC5037M	8 pin SOIC

LIFE SUPPORT POLICY

FAIRCHILD'S PRODUCTS ARE NOT AUTHORIZED FOR USE AS CRITICAL COMPONENTS IN LIFE SUPPORT DEVICES OR SYSTEMS WITHOUT THE EXPRESS WRITTEN APPROVAL OF THE PRESIDENT OF FAIRCHILD SEMICONDUCTOR CORPORATION. As used herein:

1. Life support devices or systems are devices or systems which, (a) are intended for surgical implant into the body, or (b) support or sustain life, and (c) whose failure to perform when properly used in accordance with instructions for use provided in the labeling, can be reasonably expected to result in a significant injury of the user.
2. A critical component in any component of a life support device or system whose failure to perform can be reasonably expected to cause the failure of the life support device or system, or to affect its safety or effectiveness.

www.fairchildsemi.com

TRADEMARKS

The following are registered and unregistered trademarks Fairchild Semiconductor owns or is authorized to use and is not intended to be an exhaustive list of all such trademarks.

ACEx™	ISOPLANAR™	SyncFET™
CoolFET™	MICROWIRE™	TinyLogic™
CROSSVOLT™	POP™	UHC™
E ² CMOS™	PowerTrench®	VCX™
FACT™	QFET™	
FACT Quiet Series™	QS™	
FAST®	Quiet Series™	
FASTr™	SuperSOT™-3	
GTO™	SuperSOT™-6	
HiSeC™	SuperSOT™-8	

DISCLAIMER

FAIRCHILD SEMICONDUCTOR RESERVES THE RIGHT TO MAKE CHANGES WITHOUT FURTHER NOTICE TO ANY PRODUCTS HEREIN TO IMPROVE RELIABILITY, FUNCTION OR DESIGN. FAIRCHILD DOES NOT ASSUME ANY LIABILITY ARISING OUT OF THE APPLICATION OR USE OF ANY PRODUCT OR CIRCUIT DESCRIBED HEREIN; NEITHER DOES IT CONVEY ANY LICENSE UNDER ITS PATENT RIGHTS, NOR THE RIGHTS OF OTHERS.

LIFE SUPPORT POLICY

FAIRCHILD'S PRODUCTS ARE NOT AUTHORIZED FOR USE AS CRITICAL COMPONENTS IN LIFE SUPPORT DEVICES OR SYSTEMS WITHOUT THE EXPRESS WRITTEN APPROVAL OF FAIRCHILD SEMICONDUCTOR CORPORATION. As used herein:

1. Life support devices or systems are devices or systems which, (a) are intended for surgical implant into the body, or (b) support or sustain life, or (c) whose failure to perform when properly used in accordance with instructions for use provided in the labeling, can be reasonably expected to result in significant injury to the user.
2. A critical component is any component of a life support device or system whose failure to perform can be reasonably expected to cause the failure of the life support device or system, or to affect its safety or effectiveness.

PRODUCT STATUS DEFINITIONS

Definition of Terms

Datasheet Identification	Product Status	Definition
Advance Information	Formative or In Design	This datasheet contains the design specifications for product development. Specifications may change in any manner without notice.
Preliminary	First Production	This datasheet contains preliminary data, and supplementary data will be published at a later date. Fairchild Semiconductor reserves the right to make changes at any time without notice in order to improve design.
No Identification Needed	Full Production	This datasheet contains final specifications. Fairchild Semiconductor reserves the right to make changes at any time without notice in order to improve design.
Obsolete	Not In Production	This datasheet contains specifications on a product that has been discontinued by Fairchild semiconductor. The datasheet is printed for reference information only.