

## ■ General Description

The AME5258A is a high efficiency monolithic synchronous buck regulator using a constant frequency, current mode architecture. The device is available in an adjustable version. Supply current with no load is 300µA and drops to <1µA in shutdown. The 2.5V to 5.5V input voltage range makes the AME5258A ideally suited for single Li-Ion battery-powered applications. 100% duty cycle provides low dropout operation, extending battery life in portable systems. PWM pulse skipping mode operation provides very low output ripple voltage for noise sensitive applications. At very light load, the AME5258A will automatically skip pulses in pulse skip mode operation to maintain output regulation.

The AME5258A is simple to use. As with standard LDO's, Input and output capacitor are required. The only other element is a small, low cost, 2.2µH inductor. Low output voltages are easily supported with the 0.6V feedback reference voltage. And 100% duty cycle when  $V_{in}$  approaches  $V_{out}$ .

## ■ Features

- High Efficiency: Up to 96%
- 800mA Output Current at  $V_{in}=3V$
- 2.5V to 5.5V Input Voltage Range
- 1.5MHz Constant Frequency Operation
- No Schottky Diode Required
- Low Dropout Operation: 100% Duty Cycle
- 0.6V Reference Allows Low Output Voltages
- Shutdown Mode Draws <1µA Supply Current
- Current Mode Operation for Excellent Line and Load Transient Response
- Overtemperature Protection
- Internal Soft Start
- Space Saving 5-Pin SOT-25 Package
- Meet RoHS Standards

## ■ Applications

- Cellular Phones
- Digital Cameras
- Portable Electronics
- USB Devices
- MP3 Players
- LDO Replacement

## ■ Typical Application

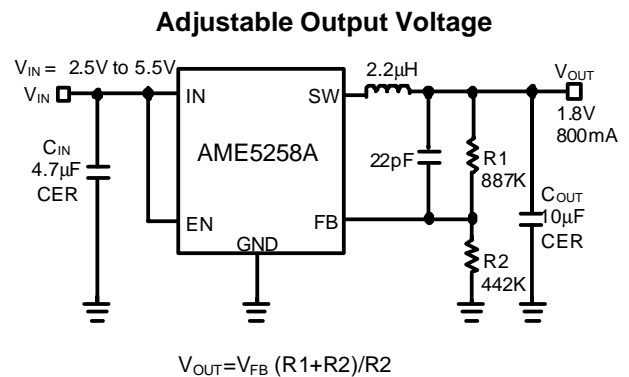


Figure 1: 1.8V at 800mA Step-Down Regulator

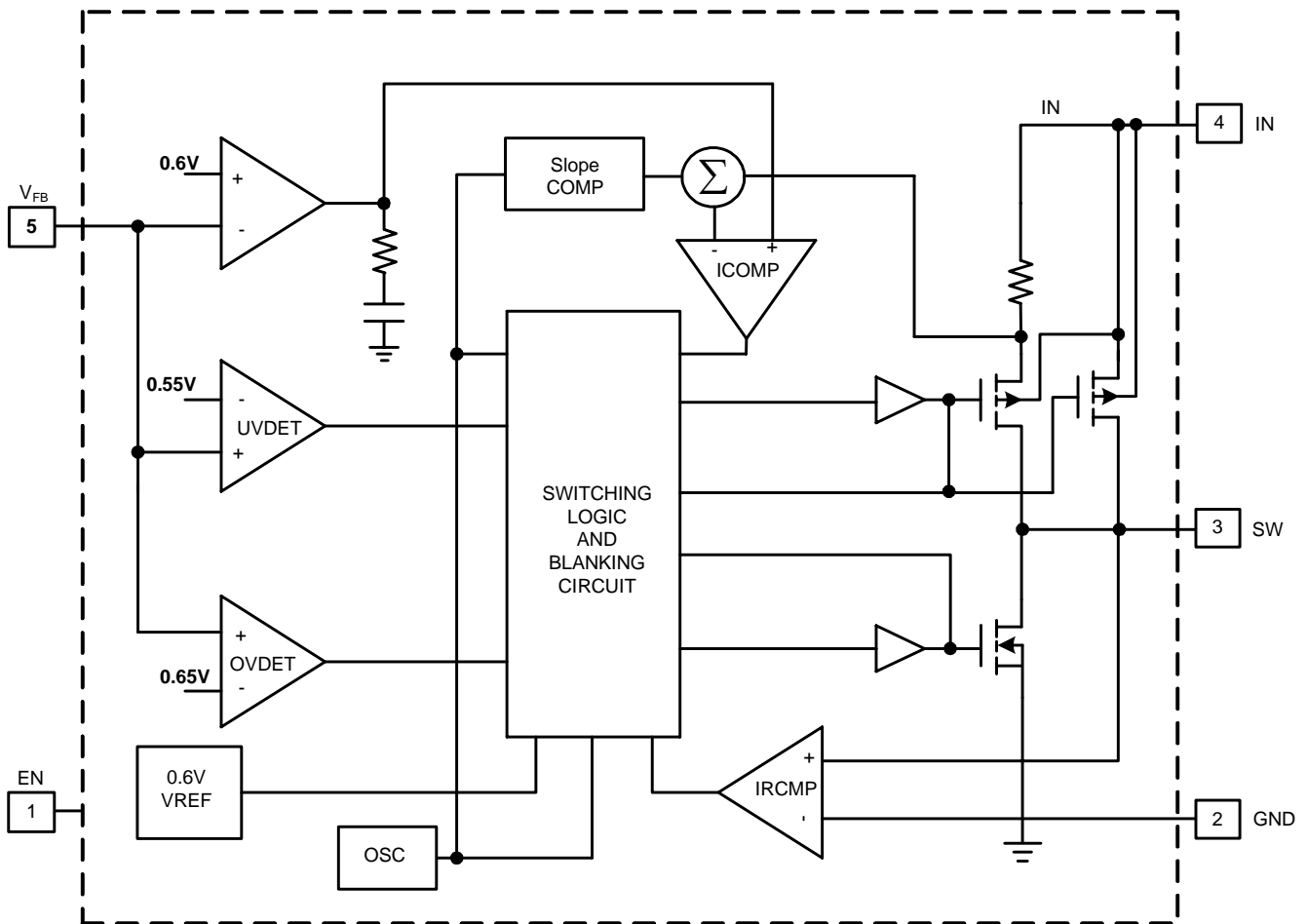
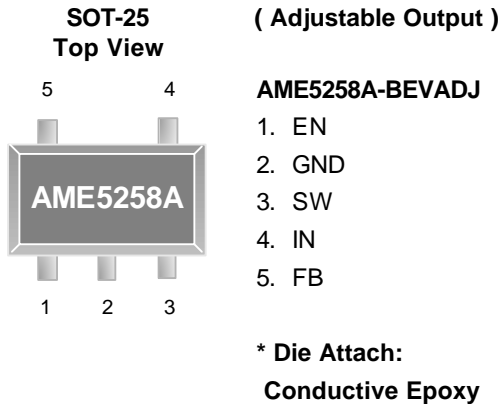
**■ Function Diagram**


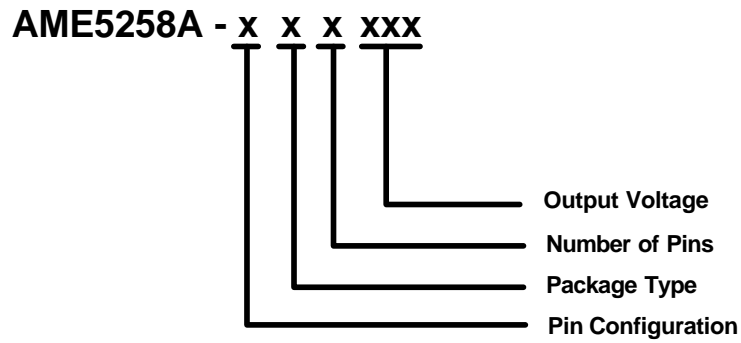
Figure 2: Founction Block Diagram

### ■ Pin Configuration



### ■ Pin Description

Pin Number	Pin Name	Pin Description
1	EN	Enable Control Input. Forcing this pin above 1.5V enables the part. Forcing this pin below 0.3V shuts down the device. In shutdown, all functions are disabled drawing <math><1\mu\text{A}</math> supply current. Do not leave EN floating.
2	GND	Ground Pin
3	SW	Switch Node Connection to Inductor. This pin connects to the drains of the internal main and synchronous power MOSFET switches.
4	IN	Main Supply Pin. Must be closely decoupled to GND, Pin2, with a 4.7 $\mu\text{F}$ or greater ceramic capacitor.
5	FB	Feedback Pin. Receives the feedback voltage from an external resistive divider across the output.

**■ Ordering Information**


Pin Configuration	Package Type	Number of Pins	Output Voltage
B 1. EN (SOT-25) 2. GND 3. SW 4. IN 5. FB	E: SOT-2X	V: 5	ADJ: Adjustable

**■ Available Options**

Part Number	Marking*	Output Voltage	Package	Operating Ambient Temperature Range
AME5258A-BEVADJ	BWMMXX	ADJ	SOT-25	-40°C to +85°C

Note:

1. The first 3 places represent product code. It is assigned by AME such as BWM.
2. A bar on top of first letter represents Green Part such as  $\bar{B}WM$ .
3. The last 3 places MXX represent Marking Code. It contains M as date code in "month", XX as LN code and that is for AME internal use only. Please refer to date code rule section for detail information.
4. Please consult AME sales office or authorized Rep./Distributor for the availability of output voltage and package type.

**■ Absolute Maximum Ratings**

Parameter	Symbol	Maximum	Unit
Input Supply Voltage	$V_{IN}$	6	V
EN, FB Voltages	$V_{EN}, V_{FB}$	$V_{IN}$	V
SW Voltage	$V_{SW}$	-0.3 to ( $V_{IN}+0.3$ )	V
P-Channel Switch Source Current (DC)	$I_{SW}$	1	A
N-Channel Switch Sink Current (DC)	$I_{SW}$	1	A
ESD Classification		C*	

Caution: Stress above the listed in absolute maximum ratings may cause permanent damage to the device.

\* HBM C: 4000V ~ 6000V

**■ Recommended Operating Conditions**

Parameter	Symbol	Rating	Unit
Ambient Temperature Range	$T_A$	-40 to +85	°C
Junction Temperature Range	$T_J$	-40 to +125	°C
Storage Temperature Range	$T_{STG}$	-65 to +150	°C

**■ Thermal Information**

Parameter	Package	Die Attach	Symbol	Maximum	Unit
Thermal Resistance* (Junction to Case)	SOT-25	Conductive Epoxy	$\theta_{JC}$	81	°C / W
Thermal Resistance (Junction to Ambient)	SOT-25		$\theta_{JA}$	260	°C / W
Internal Power Dissipation	SOT-25		$P_D$	400	mW
Solder Iron (10 Sec)**				350	°C

\* Measure  $\theta_{JC}$  on center of molding compound if IC has no tab.

\*\* MIL-STD-202G 210F

**■ Electrical Specifications**
 $T_A=25^\circ\text{C}$ .  $V_{IN}=3.6\text{V}$  unless otherwise specified.

Parameter	Symbol	Test Condition	Min	Typ	Max	Units
Input Voltage	$V_{IN}$		2.5		5.5	V
Feedback Current	$I_{FB}$				$\pm 30$	nA
Regulated Feedback Voltage	$V_{FB}$		0.5880	0.6	0.6120	V
Reference Voltage Line Regulation	$\Delta V_{FB}$	$V_{IN}=2.5\text{V to } 5.5\text{V}$		0.04	0.4	%/V
Output Voltage Line Regulation	$REG_{LINE}$	$V_{IN}=2.5\text{V to } 5.5\text{V}$		0.04	0.4	%/V
Switch Current Limit	$I_{CL}$	$V_{IN}=3\text{V}$ , $V_{FB}=0.5\text{V}$ Duty Cycle < 35%	1			A
Output Voltage Load Regulation	$V_{LOADREG}$			0.5		%
Shutdown Current	$I_{SD}$	$V_{EN}=0\text{V}$ , $V_{IN}=4.2\text{V}$		0.1	1	$\mu\text{A}$
Quiescent Current	$I_Q$	$V_{FB}=0.5\text{V}$ or $V_{OUT}=90\%$ $V_{EN}=V_{IN}=4.2\text{V}$		300	450	
Oscillator Frequency	$f_{OSC}$	$V_{IN}=2.5\text{V}$ & $I_{OUT}=100\text{mA}$	1.2	1.5	1.8	MHz
		$V_{FB}=0\text{V}$ or $V_{OUT}=0\text{V}$		210		kHz
$R_{DS(on)}$ of P-Channel FET	$R_{DS(on)(P)}$	$I_{SW}=100\text{mA}$		0.4	0.6	$\Omega$
$R_{DS(on)}$ of N-Channel FET	$R_{DS(on)(N)}$	$I_{SW}= -100\text{mA}$		0.35	0.5	$\Omega$
Switch Leakage Current	$I_{SW}$	$V_{EN}=0\text{V}$ , $V_{SW}=0\text{V}$ or $5\text{V}$ , $V_{IN}=5\text{V}$			$\pm 1$	$\mu\text{A}$
EN Input Threshold (High)	$V_{EH}$		1.5			V
EN Input Threshold (Low)	$V_{EL}$				0.3	
EN Input Current	$I_{EN}$				$\pm 1$	$\mu\text{A}$

## ■ Detailed Description

### Main Control Loop

The AME5258A uses a constant frequency, current modestepped-down architecture. Both the main (P-channel MOSFET) and synchronous (N-channel MOSFET) switches are internal. During normal operation, the internal top power MOSFET is turned on each cycle when the oscillator sets the RS latch, and turned off when the current comparator, ICOMP, resets the RS latch. The peak inductor current at which ICOMP resets the RS latch, is controlled by the output of error amplifier EA. When the load current increases, it causes a slight decrease in the feedback voltage, FB, relative to the 0.6V reference, which in turn, causes the EA amplifier's output voltage to increase until the average inductor current matches the new load current. While the top MOSFET is off, the bottom MOSFET is turned on until either the inductor current starts to reverse, as indicated by the current reversal comparator IRCMP, or the beginning of the next clock cycle. The comparator OVDET guards against transient overshoots >7.8% by turning the main switch off and keeping it off until the fault is removed.

### Pulse Skipping Mode Operation

At light loads, the inductor current may reach zero or reverse on each pulse. The bottom MOSFET is turned off by the current reversal comparator, IRCMP, and the switch voltage will ring. This is discontinuous mode operation, and is normal behavior for the switching regulator.

### Short-Circuit Protection

When the output is shorted to ground, the frequency of the oscillator is reduced to about 210kHz, 1/7 the nominal frequency. This frequency foldback ensures that the inductor current has more time to decay, thereby preventing runaway. The oscillator's frequency will progressively increase to 1.5MHz when  $V_{FB}$  or  $V_{OUT}$  rises above 0V.

### Dropout Operation

As the input supply voltage decreases to a value approaching the output voltage, the duty cycle increases toward the maximum on-time. Further reduction of the supply voltage forces the main switch to remain on for more than one cycle until it reaches 100% duty cycle. The output voltage will then be determined by the input voltage minus the voltage drop across the P-channel MOSFET and the inductor. An important detail to remember is that at low input supply voltages, the RDS(ON) of the P-channel switch increases (see Typical Performance Characteristics). Therefore, the user should calculate the power dissipation when the AME5258A is used at 100% duty cycle with low input Voltage.

## ■ Application Information

### Inductor Selection

For most applications, the value of the inductor will fall in the range of 1 $\mu$ H to 4.7 $\mu$ H. Its value is chosen based on the desired ripple current. Large value inductors lower ripple current and small value inductors result in higher ripple currents. Higher  $V_{IN}$  or  $V_{OUT}$  also increases the ripple current as shown in equation 1. A reasonable starting point for setting ripple current is  $I_L = 320\text{mA}$  (40% of 800mA).

$$D I_L = \frac{1}{f \times L} \times V_{OUT} \left( 1 - \frac{V_{OUT}}{V_{IN}} \right)$$

The DC current rating of the inductor should be at least equal to the maximum load current plus half the ripple current to prevent core saturation. Thus, a 960mA rated inductor should be enough for most applications (800mA+160mA). For better efficiency, choose a low DC-resistance inductor.



### Inductor Core Selection

Once the value for L is known, the type of inductor must be selected. High efficiency converters generally cannot afford the core loss found in low cost powdered iron cores, forcing the use of more expensive ferrite or mollypermalloy cores. Actual core loss is independent of core size for a fixed inductor value but it is very dependent on the inductance selected. As the inductance increases, core losses decrease. Unfortunately, increased inductance requires more turns of wire and therefore copper losses will increase. Ferrite designs have very low core losses and are preferred at high switching frequencies, so design goals can concentrate on copper loss and preventing saturation. Ferrite core material saturates "hard", which means that inductance collapses abruptly when the peak design current is exceeded. This result in an abrupt increase in inductor ripple current and consequent output voltage ripple. Do not allow the core to saturate! Different core materials and shapes will change the size/current and price/current relationship of an inductor. Toroid or shielded pot cores in ferrite or permalloy materials are small and don't radiate energy but generally cost more than powdered iron core inductors with similar characteristics. The choice of which style inductor to use mainly depends on the price vs. size requirements and any radiated field/EMI requirements.

### C<sub>IN</sub> and C<sub>OUT</sub> Selection

The input capacitance, C<sub>IN</sub>, is needed to filter the trapezoidal current at the source of the top MOSFET. To prevent large ripple voltage, a low ESR input capacitor sized for the maximum RMS current should be used. RMS current is given by :

$$I_{RMS} = I_{OUT} (max) \times \frac{V_{OUT}}{V_{IN}} \times \sqrt{\frac{V_{IN}}{V_{OUT}} - 1}$$

This formula has a maximum at  $V_{IN} = 2V_{OUT}$ , where  $I_{RMS} = I_{OUT}/2$ . This simple worst-case condition is commonly used for design because even significant deviations do not offer much relief. Note that ripple current ratings from capacitor manufacturers are often based on only 2000 hours of life which makes it advisable to further derate the capacitor, or choose a capacitor rated at a higher temperature than required.

Several capacitors may also be paralleled to meet size or height requirements in the design. The selection of C<sub>OUT</sub> is determined by the effective series resistance (ESR) that is required to minimize voltage ripple and load step transients, as well as the amount of bulk capacitance that is necessary to ensure that the control loop is stable. Loop stability can be checked by viewing the load transient response as described in a later section.

The output ripple,  $V_{OUT}$ , is determined by :

$$\Delta V_{OUT} \approx \Delta I_L \hat{e} ESR + \frac{1}{8f \times C_{OUT}} \frac{\hat{u}}{\hat{u}}$$

The output ripple is highest at maximum input voltage since IL increases with input voltage. Multiple capacitors placed in parallel may be needed to meet the ESR and RMS current handling requirements. Dry tantalum, special polymer, aluminum electrolytic and ceramic capacitors are all available in surface mount packages. Special polymer capacitors offer very low ESR but have lower capacitance density than other types. Tantalum capacitors have the highest capacitance density but it is important to only use types that have been surge tested for use in switching power supplies. Aluminum electrolytic capacitors have significantly higher ESR but can be used in cost-sensitive applications provided that consideration is given to ripple current ratings and long term reliability. Ceramic capacitors have excellent low ESR characteristics but can have a high voltage coefficient and audible piezoelectric effects. The high Q of ceramic capacitors with trace inductance can also lead to significant ringing

### Using Ceramic Input and Output Capacitors

Higher values, lower cost ceramic capacitors are now becoming available in smaller case sizes. Their high ripple current, high voltage rating and low ESR make them ideal for switching regulator applications. However, care must be taken when these capacitors are used at the input and output. When a ceramic capacitor is used at the input and the power is supplied by a wall adapter through long wires, a load step at the output can induce ringing at the input,  $V_{IN}$ . At best, this ringing can couple to the output and be mistaken as loop instability. At worst, a sudden inrush of current through the long wires can potentially cause a voltage spike at  $V_{IN}$  large enough to damage the part.

**Output Voltage Programming**

The output voltage is set by an external resistive divider according to the following equation :

$$V_{OUT} = V_{REF} \times \left(1 + \frac{R_2}{R_1}\right)$$

Where VREF equals to 0.6V typical. The resistive divider allows the FB pin to sense a fraction of the output voltage as shown in Figure 3.

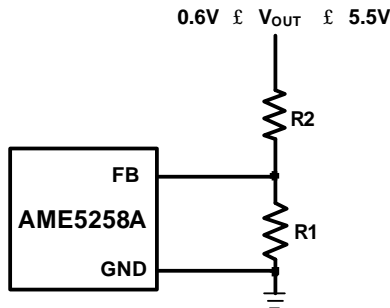


Figure 3: Setting the AME5258A Output Voltage

**Thermal Considerations**

In most applications the AME5258A does not dissipate much heat due to its high efficiency. But, in applications where the AME5258A is running at high ambient temperature with low supply voltage and high duty cycles, such as in dropout, the heat dissipated may exceed the maximum junction temperature of the part. If the junction temperature reaches approximately 160°C, both power switches will be turned off and the SW node will become high impedance. To avoid the AME5258A from exceeding the maximum junction temperature, the user will need to do some thermal analysis. The goal of the thermal analysis is to determine whether the power dissipated exceeds the maximum junction temperature of the part. The temperature rise is given by:

$$T_R = (PD)(\theta_{JA})$$

Where PD is the power dissipated by the regulator and  $\theta_{JA}$  is the thermal resistance from the junction of the die to the ambient temperature.

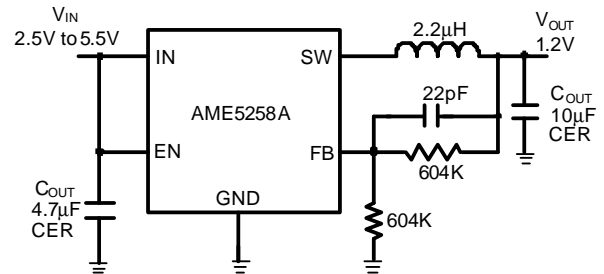


Figure 4: 1.2V Step-Down Regulator

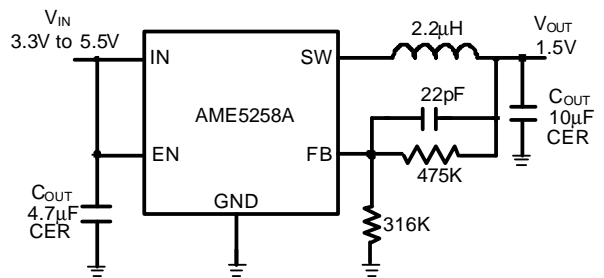


Figure 5: 1.5V Step-Down Regulator

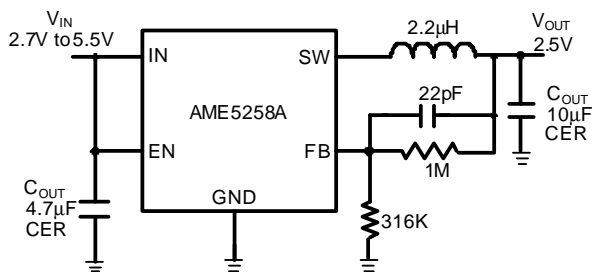


Figure 6: 2.5V Step-Down Regulator

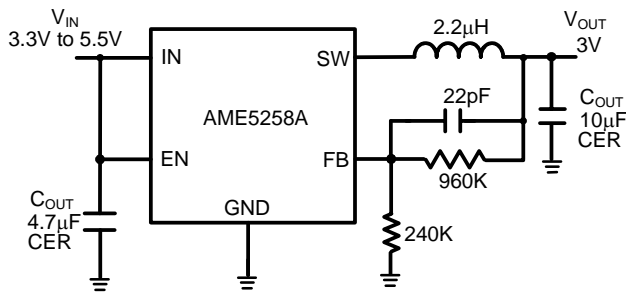
**AME5258A**
**Synchronous Buck Converter**


Figure 7: 3V Step-Down Regulator

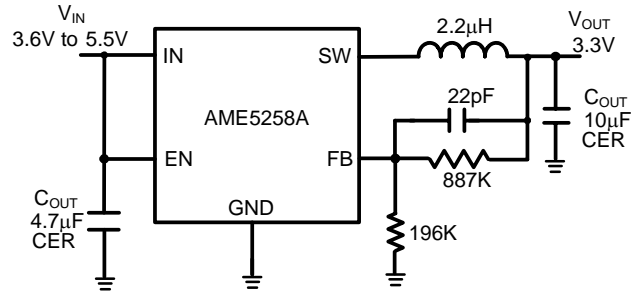


Figure 8: 3.3V Step-Down Regulator

**PC Board Layout Checklist**

When laying out the printed circuit board, the following checklist should be used to ensure proper operation of the AME5258A. These items are also illustrated graphically in Figures 9. Check the following in your layout:

1. The power traces, consisting of the GND trace, the SW trace and the  $V_{IN}$  trace should be kept short, direct and wide.
2. Does the  $V_{FB}$  pin connect directly to the feedback resistors? The resistive divider R1/R2 must be connected between the (+) plate of  $C_{OUT}$  and ground.
3. Does the (+) plate of  $C_{IN}$  connect to  $V_{IN}$  as closely as possible? This capacitor provides the AC current to the internal power MOSFETs.
4. Keep the switching node, SW, away from the sensitive  $V_{FB}$  node.
5. Keep the (-) plates of  $C_{IN}$  and  $C_{OUT}$  as close as possible.

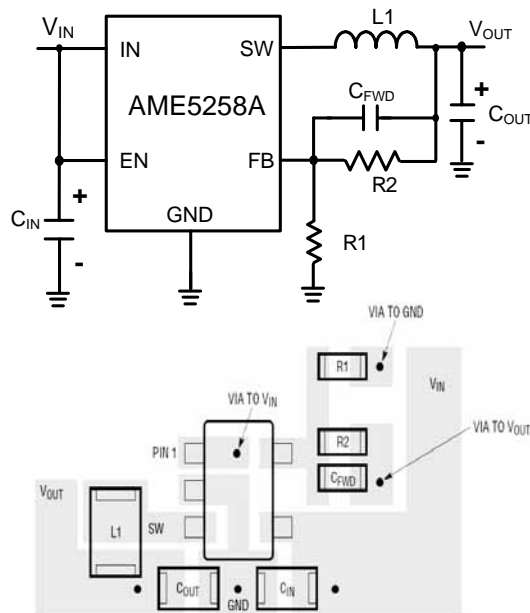
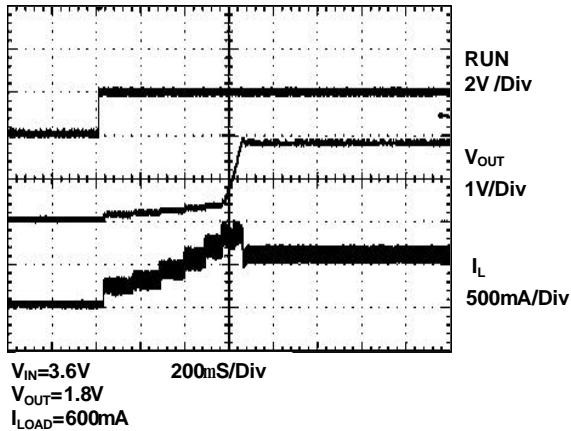
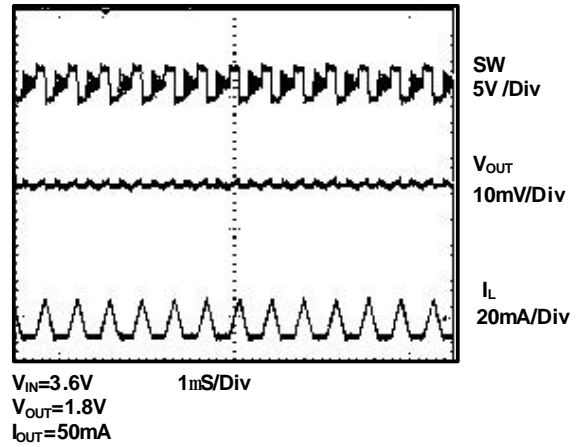
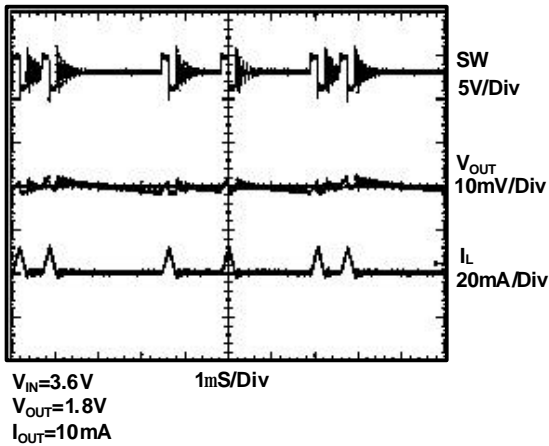
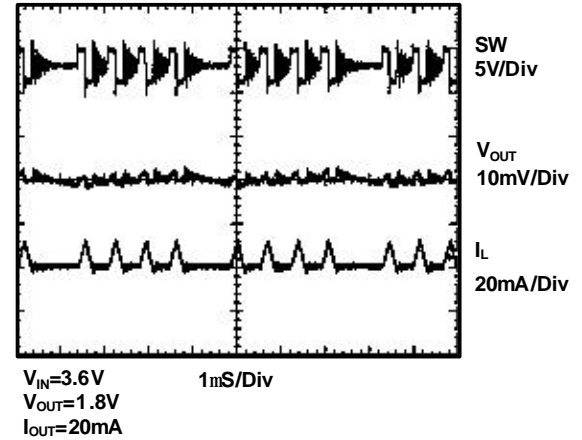
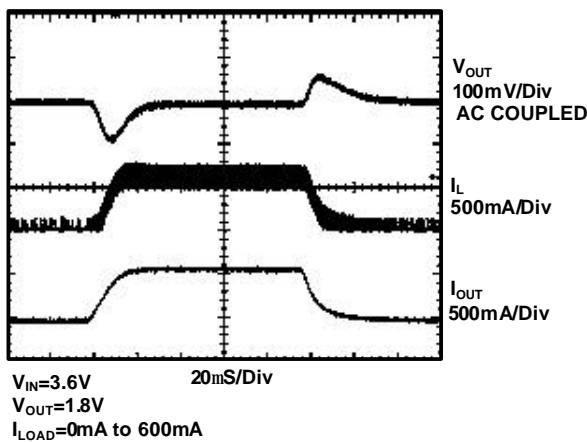
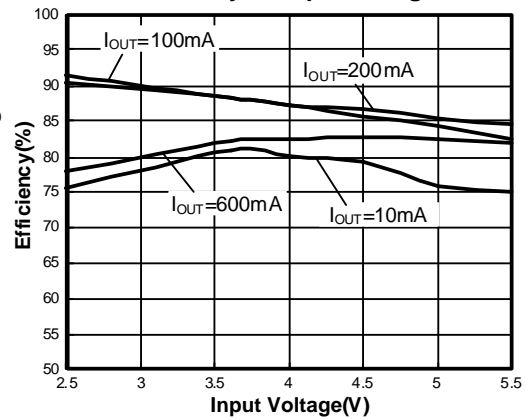
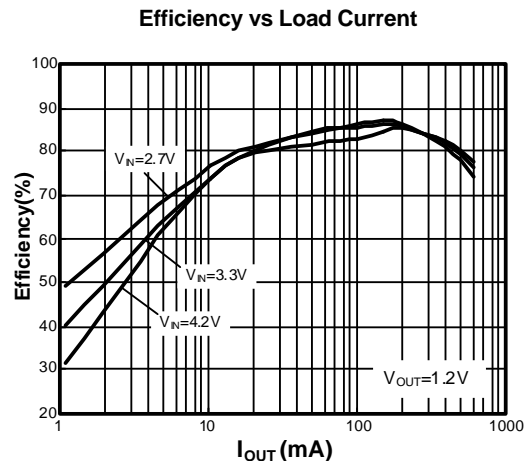
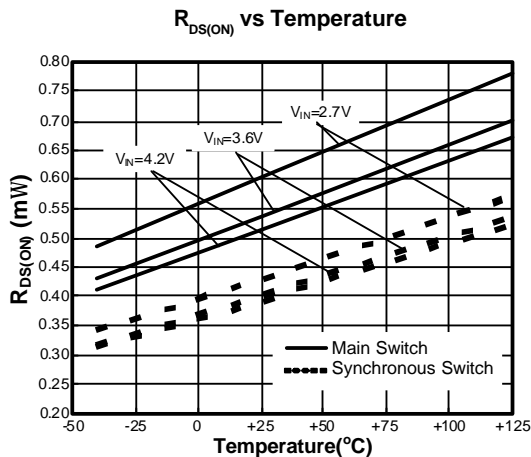
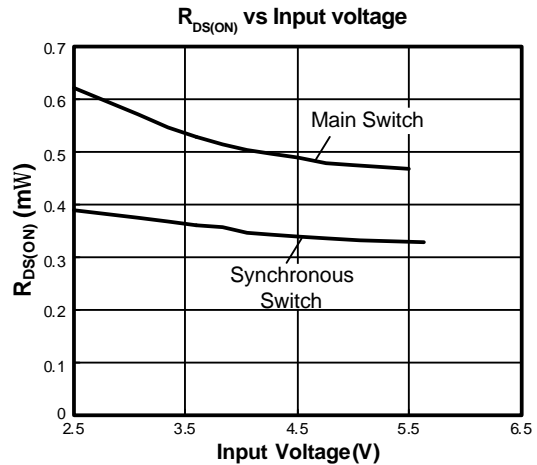
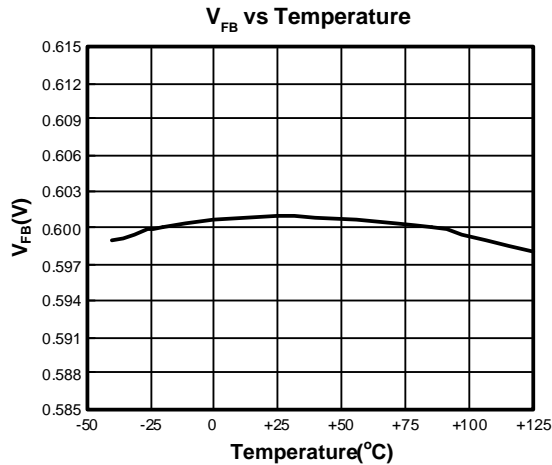
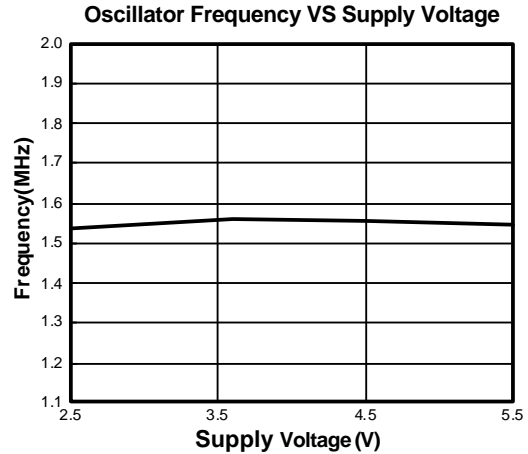
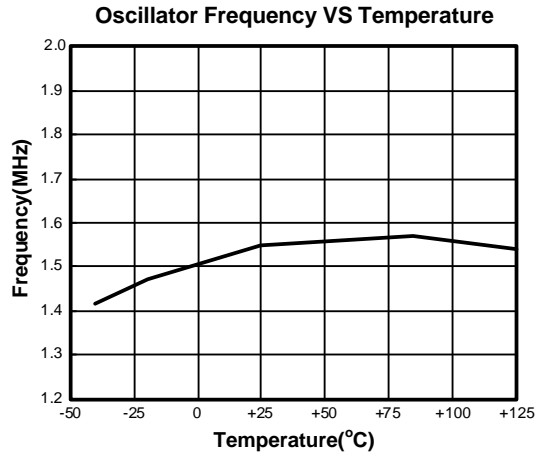
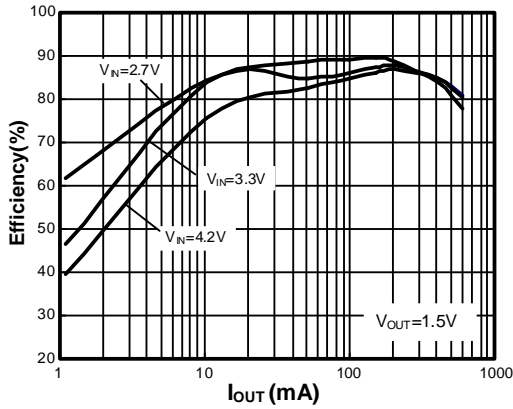
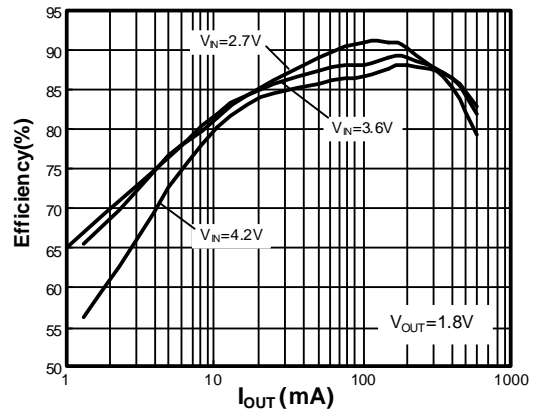
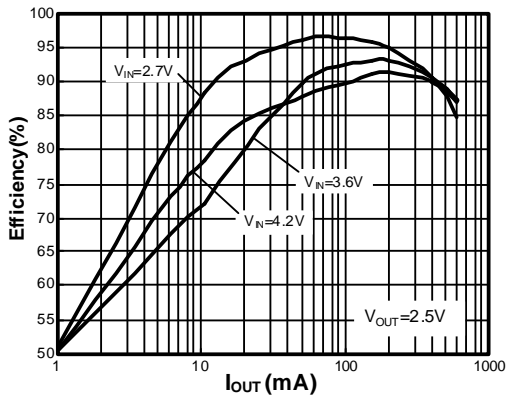
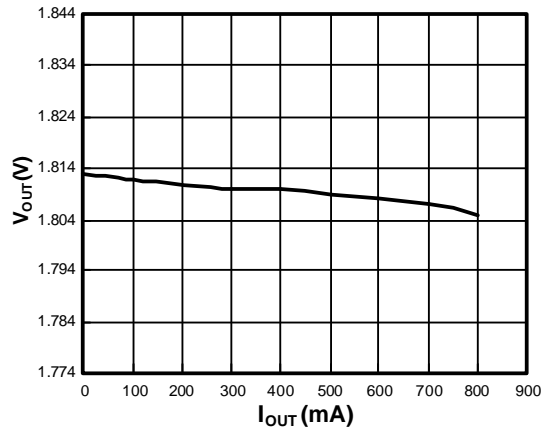
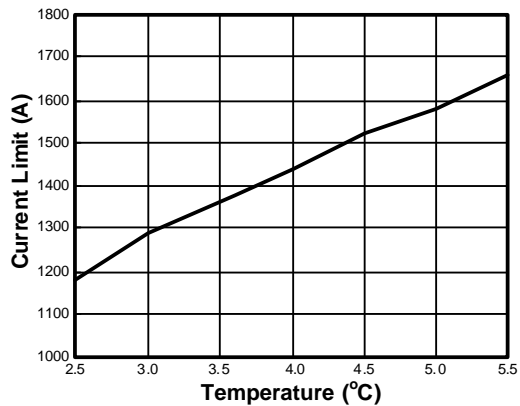


Figure 9: AME5258A Adjustable Voltage Regulator Layout Diagram

**Start-UP form Shutdown**

**Pluse Skipping Mode**

**Pluse Skipping Mode**

**Pluse Skipping Mode**

**Load Step**

**Efficiency vs Input voltage**


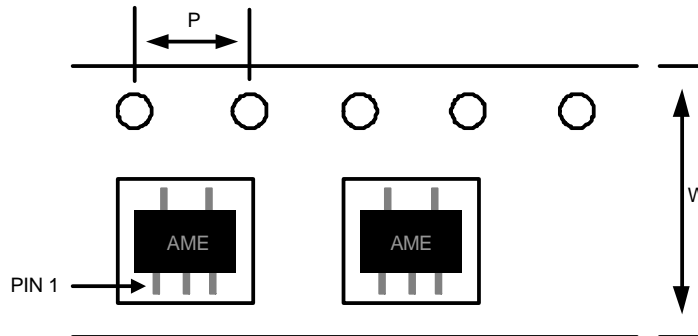


**Efficiency vs Load Current**

**Efficiency vs Load Current**

**Efficiency vs Load Current**

**Output Voltage vs Load Current**

**Current Limit vs Input Voltage**


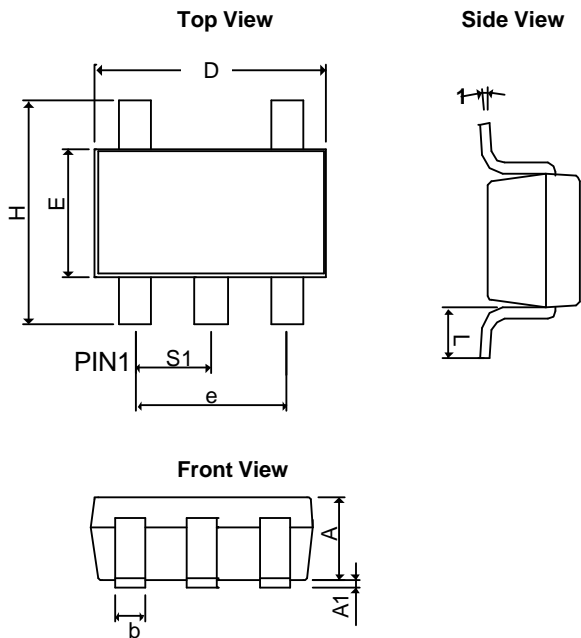
**■ Date Code Rule**

Month Code	
1: January	7: July
2: February	8: August
3: March	9: September
4: April	A: October
5: May	B: November
6: June	C: December

Marking						Year
A	A	A	M	X	X	xxx0
A	A	A	M	X	<u>X</u>	xxx1
A	A	A	M	<u>X</u>	X	xxx2
A	A	A	M	<u>X</u>	<u>X</u>	xxx3
A	A	A	<u>M</u>	X	X	xxx4
A	A	A	<u>M</u>	X	<u>X</u>	xxx5
A	A	A	<u>M</u>	<u>X</u>	X	xxx6
A	A	A	<u>M</u>	<u>X</u>	<u>X</u>	xxx7
A	A	<u>A</u>	M	X	X	xxx8
A	A	<u>A</u>	M	X	<u>X</u>	xxx9

**■ Tape and Reel Dimension**
**SOT-25**

**Carrier Tape, Number of Components Per Reel and Reel Size**

Package	Carrier Width (W)	Pitch (P)	Part Per Full Reel	Reel Size
SOT-25	8.0±0.1 mm	4.0±0.1 mm	3000pcs	180±1 mm

**■ Package Dimension**
**SOT-25**


SYMBOLS	MILLIMETERS		INCHES	
	MIN	MAX	MIN	MAX
A	0.90	1.30	0.0354	0.0512
A <sub>1</sub>	0.00	0.15	0.0000	0.0059
b	0.30	0.55	0.0118	0.0217
D	2.70	3.10	0.1063	0.1220
E	1.40	1.80	0.0551	0.0709
e	1.90 BSC		0.07480 BSC	
H	2.60	3.00	0.10236	0.11811
L	0.37BSC		0.0146BSC	
q1	0°	10°	0°	10°
S <sub>1</sub>	0.95BSC		0.0374BSC	





**www.ame.com.tw**  
**E-Mail: sales@ame.com.tw**

Life Support Policy:

These products of AME, Inc. are not authorized for use as critical components in life-support devices or systems, without the express written approval of the president of AME, Inc.

AME, Inc. reserves the right to make changes in the circuitry and specifications of its devices and advises its customers to obtain the latest version of relevant information.

© AME, Inc. , September 2009  
Document: 1265-DS5258A -A.01

**Corporate Headquarter**

**AME, Inc.**

2F, 302 Rui-Guang Road, Nei-Hu District

Taipei 114, Taiwan.

Tel: 886 2 2627-8687

Fax: 886 2 2659-2989