

■ General Description

The AME5248A is a fixed-frequency current mode synchronous PWM step down converter that is capable of delivering 600mA output current while achieving peak efficiency of 95%. Under light load conditions, the AME5248A operates in a power saving mode that consumes just around 20µA of supply current, maximizing battery life in portable applications. The AME5248A operates with a fixed frequency of 1.5MHz, minimizing noise in noise-sensitive applications and allowing the use of small external components. The AME5248A is an ideal solution for applications powered by Li-Ion batteries or other portable applications that require small board space.

The AME5248A is available in a variety of fixed output voltage options, 1.0V, 1.2V, 1.3V, 1.5V, 1.8V, 2.5V, 2.7V, 2.8V, and 3.3V, and is also available in an adjustable output voltage version capable of generating output voltages from 0.5V to V_{IN} . The AME5248A is available in the tiny 5-pin SOT-25 and TSOT-25 package.

■ Features

- High Efficiency - Up to 95%
- Very Low 20µA Quiescent Current
- Guaranteed 600mA Output Current
- 1.5MHz Constant Frequency Operation PWM
- Internal Synchronous Rectifier Eliminates Schottky Diode
- Adjustable Output Voltages From 0.5V to V_{IN}
- Fixed Output Voltage Options Available 1.0V, 1.2V, 1.3V, 1.5V, 1.8V, 2.5V, 2.7V, 2.8V and 3.3V
- 100% Duty Cycle Low-Dropout Operation
- 0.1µA Shutdown Current
- Require Tiny Capacitors and Inductor
- Tiny SOT-25 and TSOT-25 Package
- All AME's Lead Free Products Meet RoHS Standards

■ Applications

- Blue Tooth Headsets
- Portable Audio Players
- Mobile Phones
- Wireless and DSL Modems
- Digital Still Cameras
- Portable Instruments

■ Typical Application

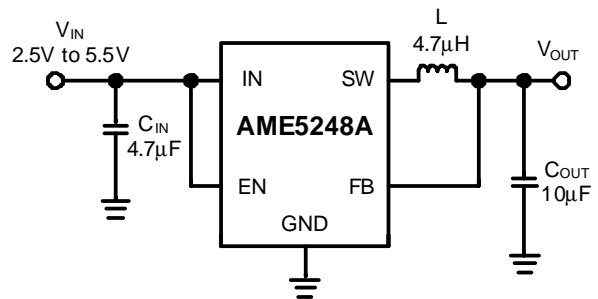

Figure 1. Fixed Voltage Regulator

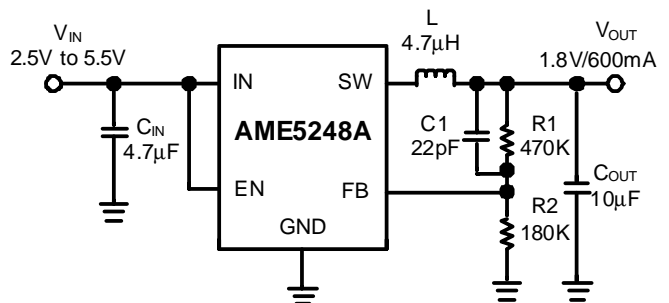
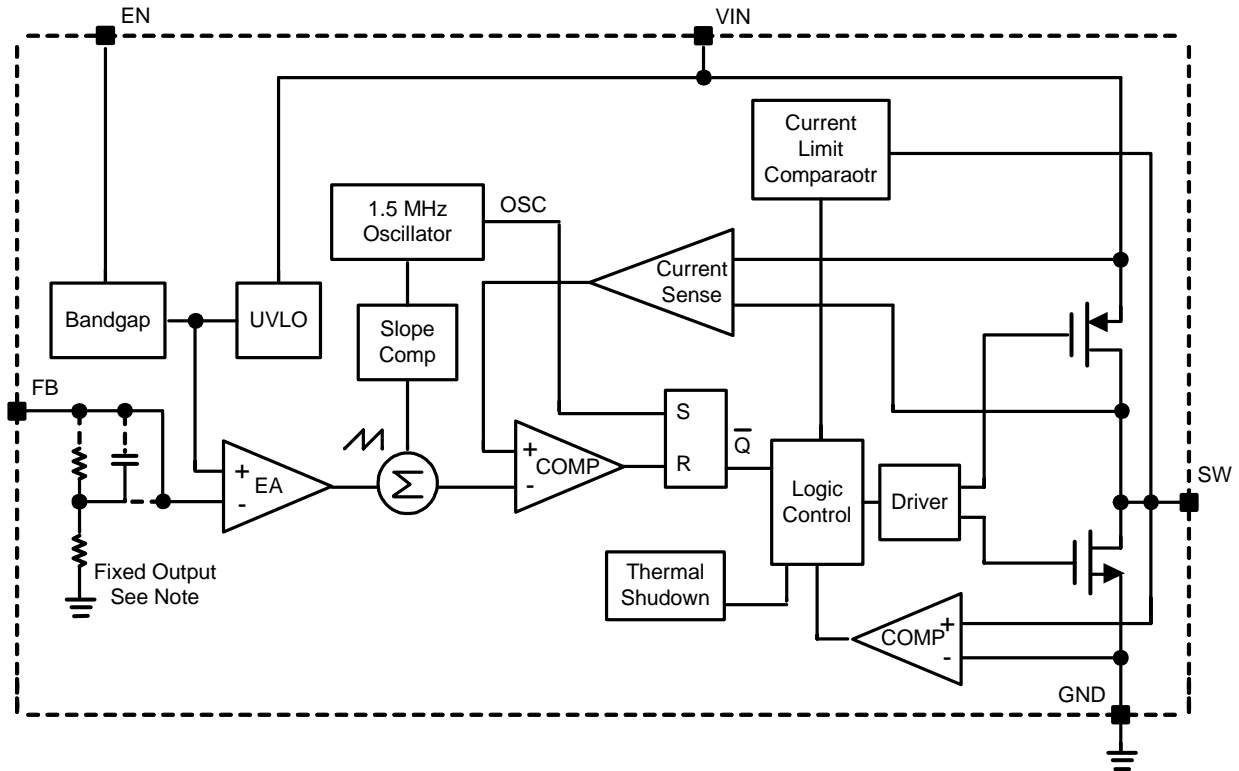

Figure 2. Adjustable Voltage Regulator

■ Function Block Diagram

Figure 3

Note: For the fixed output version the internal feedback divider is activated.

For the adjustable version the internal feedback divider is disabled, and the FB pin is directly connected to the internal EA amplifier.

■ Pin Configuration

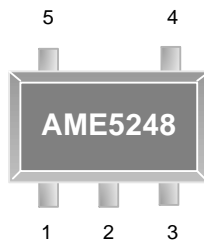
SOT-25/TSOT-25
Top View



AME5248A-AEVxxx

1. IN
2. GND
3. EN
4. FB/OUT
5. SW

Die Attach:
Conductive Epoxy

■ Pin Description

Pin Number	Pin Name	Pin Description
1	IN	Input Supply Voltage Pin. Bypass this pin with a capacitor as close to the device as possible
2	GND	Ground Tie directly to ground plane.
3	EN	Enable Control Input. The enable pin is an active high control. Tie this pin above 1.4V to enable the device. Tie this pin below 0.4V to shut down the device. In shutdown, all function are disabled. Do not leave EN pin floating.
4	FB/OUT	FB:Output voltage Feedback input. Set the output voltage by selecting values for R1 and R2 using: $R1 = R2 (V_{OUT}/0.5V - 1)$ Connect the ground of the feedback network to an AGND (Analog Ground) plane which should be tied directly to the GND pin. OUT:Output Pin
5	SW	Switch Node Connection to Inductor.

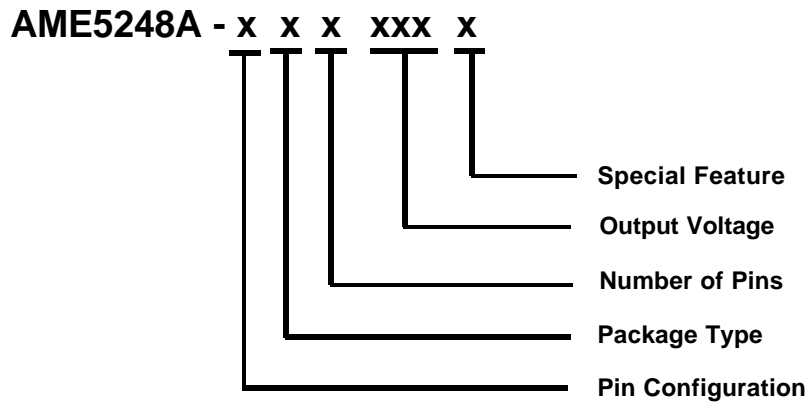
■ Ordering Information

Pin Configuration	Package Type	Number of Pins	Output Voltage	Special Feature
A 1. IN <small>(SOT-25)</small> 2. GND <small>(TSOT-25)</small> 3. EN 4. FB/OUT 5. SW	E: SOT-2X	V: 5	ADJ: Adjustable 100: 1.0V 120: 1.2V 130: 1.3V 150: 1.5V 180: 1.8V 250: 2.5V 270: 2.7V 280: 2.8V 330: 3.3V	N/A: SOT-25 L: TSOT-25 (Low Profile)

■ Available Options

Part Number	Marking*	Output Voltage	Package	Operating Ambient Temperature Range
AME5248A-AEVADJ	BWNMXX	ADJ	SOT-25	-40°C to +85°C
AME5248A-AEVADJL	BWNMXX	ADJ	TSOT-25	-40°C to +85°C

Note:

1. The first 3 places represent product code. It is assigned by AME such as BWN.
2. A bar on top of first letter represents Green Part such as \bar{B} WN.
3. The last 3 places MXX represent Marking Code. It contains M as date code in "month", XX as LN code and that is for AME internal use only. Please refer to date code rule section for detail information.
4. Please consult AME sales office or authorized Rep./Distributor for the availability of output voltage and package type.

■ Absolute Maximum Ratings

Parameter	Symbol	Maximum	Unit
Input Voltage	V_{IN}	-0.3 to +6.5	V
EN, FB	V_{EN}, V_{FB}	-0.3 to V_{IN}	V
SW, V_{OUT}	V_{SW}, V_{OUT}	-0.3 to V_{IN}	V
ESD Classification	B*		

Caution: Stress above the listed absolute maximum rating may cause permanent damage to the device.

* HBM B:2000V~3999V

■ Recommended Operating Conditions

Parameter	Symbol	Rating	Unit
Ambient Temperature Range	T_A	-40 to +85	°C
Junction Temperature Range	T_J	-40 to +125	
Storage Temperature Range	T_{STG}	-65 to +150	

■ Thermal Information

Parameter	Package	Die Attach	Symbol	Maximum	Unit
Thermal Resistance (Junction to Case)	SOT-25* TSOT-25	Conductive Epoxy	θ_{JC}	81	°C / W
Thermal Resistance (Junction to Ambient)			θ_{JA}	260	
Internal Power Dissipation			P_D	400	mW
Solder Iron (10 Sec)**				350	°C

* Measure θ_{JC} on backside center of molding compound if IC has no tab.

** MIL-STD-202G 210F

■ Electrical Specifications
 $V_{IN}=3.6V$, $EN=V_{IN}$, $T_A = 25^{\circ}C$, unless otherwise noted

Parameter	Symbol	Test Condition	Min	Typ	Max	Units
Input Voltage	V_{IN}		2.5		5.5	V
Output Voltage Accuracy (by every fixed output voltage)	ΔV_{OUT}	$V_{IN}=2.5$ to $5.5V$, $V_{OUT}=1.0V$ $0A < I_{OUT} < 600mA$	-3		3	%
		$V_{IN}=2.5$ to $5.5V$, $V_{OUT}=1.2V$ $0A < I_{OUT} < 600mA$	-3		3	
		$V_{IN}=2.5$ to $5.5V$, $V_{OUT}=1.5V$ $0A < I_{OUT} < 600mA$	-3		3	
		$V_{IN}=2.5$ to $5.5V$, $V_{OUT}=1.8V$ $0A < I_{OUT} < 600mA$	-3		3	
		$V_{IN}=V_{OUT}+\Delta V$ to $5.5V$ (Note 1) $V_{OUT}=2.5V$, $0A < I_{OUT} < 600mA$	-3		3	
		$V_{IN}=V_{OUT}+\Delta V$ to $5.5V$ (Note 1) $V_{OUT}=2.7V$, $0A < I_{OUT} < 600mA$	-3		3	
		$V_{IN}=V_{OUT}+\Delta V$ to $5.5V$ (Note 1) $V_{OUT}=2.8V$, $0A < I_{OUT} < 600mA$	-3		3	
		$V_{IN}=V_{OUT}+\Delta V$ to $5.5V$ (Note 1) $V_{OUT}=3.3V$, $0A < I_{OUT} < 600mA$	-3		3	
Output Voltage Accuracy (Adj)	ΔV_{OUT}	$V_{IN}=V_{OUT}+\Delta V$ to $5.5V$ (Note 1) $0A < I_{OUT} < 600mA$	-3		3	
Adjustable Output Range	V_{OUT}		V_{FB}		$V_{IN}-0.2$	V
Feedback Voltage	V_{FB}	$T_A=25^{\circ}C$	0.490	0.5	0.510	V
		$T_A=-40^{\circ}C$ to $+85^{\circ}C$	0.488	0.5	0.512	
Feedback Pin Bias Current	I_{FB}		-50		50	nA
Quiescent Current	I_Q	$V_{FB}=0.45V$ or $V_{OUT}=90\%$, $I_{OUT}=0A$		300	400	μA
		$V_{FB}=0.52V$ or $V_{OUT}=104\%$, $I_{OUT}=0A$		20	35	
Shutdown Current	I_{SHDN}	$V_{EN}=0V$, $V_{IN}=4.2V$		0.1	1	
Reference Voltage Line Regulation	ΔV_{FB}	2.5 V_{IN} 5.5V			0.4	%V
Output Voltage Line Regulation	REG_{LINE}	2.5 V_{IN} 5.5V			0.4	
Output Voltage Load Regulation	REG_{LOAD}	$I_{OUT}=100mA$ to $600mA$		0.5		%

■ Electrical Specifications (Contd.)
 $V_{IN}=3.6V$, $EN=V_{IN}$, $T_A = 25^{\circ}C$, unless otherwise noted

Parameter	Symbol	Test Condition	Min	Typ	Max	Units
High-side Switch On-Resistance	$R_{DS,ON,HI}$	$I_{SW}=100mA$		0.4	0.6	Ω
Low-side Switch On-Resistance	$R_{DS,ON,LO}$	$I_{SW}=-100mA$		0.35	0.5	
Switch Current Limit	$I_{SW,CL}$	$V_{IN}=3V$, $V_{OUT}=1.2V$	1	1.25		A
Switch Leakage Current	$I_{SW,LK}$	$V_{EN}=0V$, $V_{SW}=0V$ or $3.6V$, $V_{IN}=3.6V$		0.01	1	μA
Switch Frequency	f_{OSC}	$V_{FB}=0.5V$ or $V_{OUT}=100\%$	1.2	1.5	1.8	MHz
Short Circuit Oscillator Frequency	$f_{OSC,SCR}$	$V_{FB}=0V$ or $V_{OUT}=0V$		0.21		
Maximum Duty Cycle	D_{MAX}		100			%
Input Undervoltage Lockout	V_{UVLO}	V_{IN} Rising	2	2.15	2.3	V
Input Undervoltage Lockout Hysteresis	$V_{UVLO,HYST}$			0.1		
Enable High (Enabled the Device)	$V_{EN,HI}$		1.4			
Enable Low (Shutdown the Device)	$V_{EN,LO}$				0.4	
EN Input Current (Enable the Device)	I_{EN}			0.01	1	μA
Thermal Shutdown Temperature	OTP	Shutdown, temperature increasing		160		$^{\circ}C$
Thermal Shutdown Hysteresis	OTH	Restore, temperature increasing		30		

 Note 1: $\Delta V=I_{OUT} \times R_{DS,ON,HI}$

■ Detailed Description

Main Control Loop

The AME5248A utilizes a fixed-frequency, current-mode PWM control scheme combined with fully-integrated power MOSFETs to produce a compact and efficient step-down DC-DC solution. During normal operation the high-side MOSFET turns on each cycle and remains on until the current comparator turns it off. At this point the low-side MOSFET turns on and remains on until either the end of the switching cycle or until the inductor current approaches zero. The error amplifier adjusts the current comparator's threshold according to the load current to ensure that the output voltage remains in regulation.

Light Load Power Saving Mode Operation

The AME5248A is capable of Power Saving Mode Operation in which the internal power MOSFETs operate intermittently based on load demand.

In Power Saving Mode operation, the peak current of the inductor is set to a certain value which increases as the input voltage increases, such as 260mA for 3.6V input voltage and 340mA for 5.5V input voltage, approximately. Each switching event can last from a single cycle at very light loads to few cycles within the active intervals at moderate loads. Between these switching intervals, the unneeded circuitry are turned off, reducing the quiescent current to 20 μ A. In this turned off state, the load current is being supplied solely from the output capacitor. As the output voltage droops, the internal comparator trips and turns on the circuits. This process repeats at a rate depends on the load demand.

Dropout Operation

As the input supply voltage decreases to a value approaching the output voltage, the duty cycle increases toward the maximum on-time. Further reduction of the supply voltage forces the main switch to remain on for more than one cycle until it reaches 100% duty cycle. The output voltage will then be determined by the input voltage minus the voltage drop across the P-channel MOSFET and the inductor.

Current Limit Protection

The AME5248A has current limiting protection to prevent excessive stress on itself and external components.

The internal current limit comparator will disable the power device at a switch peak current limit. Under extreme overloads, such as short-circuit conditions, the AME5248A reduces its oscillator frequency to around 210KHz to allow further inductor current reduction and to minimize power dissipation.

Under Voltage Protection

The AME5248A has an UVP comparator to turn the power device off in case the input voltage or battery voltage is too low.

Soft Start

The AME5248A integrates a soft start function that prevents input inrush current and output overshoot during start-up. During start-up the switch current limit is increased in steps. The start-up time thereby depends on the output capacitor and load current demanded at start-up. Typical start-up times with a 10 μ F output capacitor, 3.6V input voltage and 1.5V output voltage, for 600mA load is 700 μ s, and 150 μ s for 1mA load.

Thermal Shutdown

The device protects itself from overheating with an internal thermal shutdown circuit. If the junction temperature exceeds the thermal shutdown trip point, the device turns off. The part is restarted when the junction temperature drops 30°C below the thermal shutdown trip point.

■ Application Information

The typical AME5248A application circuit is shown in Figure 1. The external component selection is driven by the load requirement.

Inductor Selection

Although the inductor does not influence the operating frequency, the inductor value has a direct effect on ripple current. The inductor ripple current I_L decreases with higher inductance and increases with higher V_{IN} or V_{OUT} :

$$\Delta I_L = \frac{V_{IN} - V_{OUT}}{L \times f_{SW}} \times \frac{V_{OUT}}{V_{IN}}$$

The inductor must have a saturation (incremental) current rating equal to the peak switch-current limit. For high efficiency, minimize the inductor's DC resistance.

The inductor value also has an effect on Power Saving Mode operation. Lower inductor values (higher ripple current) will cause the transition from PWM to Power Saving Mode to occur at lower load currents, which can cause a dip in efficiency in the upper range of low current operation.

Inductor Core Selection

Once the value for L is known, the type of inductor must be selected. High efficiency converters generally cannot afford the core loss found in low cost powdered iron cores, forcing the use of more expensive ferrite or molypermalloy cores. Actual core loss is independent of core size for a fixed inductor value but it is very dependent on the inductance selected. As the inductance increases, core losses decrease. Unfortunately, increased inductance requires more turns of wire and therefore copper losses will increase. Ferrite designs have very low core losses and are preferred at high switching frequencies, so design goals can concentrate on copper loss and preventing saturation. Ferrite core material saturates "hard", which means that inductance collapses abruptly when the peak design current is exceeded. This results in an abrupt increase in inductor ripple current and consequent output voltage ripple. Do not allow the core to saturate! Different core materials and shapes will change the size/current and price/current relationship of an inductor.

Toroid or shielded pot cores in ferrite or permalloy materials are small and don't radiate energy but generally cost more than powdered iron core inductors with similar characteristics. The choice of which style inductor to use mainly depends on the price vs. size requirements and any radiated field/EMI requirements.

Input Capacitor Selection

In continuous mode, the source current of the main power MOSFET is a square wave of duty cycle V_{OUT}/V_{IN} . To prevent large voltage transients, a low ESR input capacitor sized for the maximum RMS current must be used. The input filter capacitor supplies current to the main power MOSFET of AME5248A in the first half of each cycle and reduces voltage ripple imposed on the input power source. A ceramic capacitor's low ESR provides the best noise filtering of input voltage spikes due to this rapidly changing current. Select a capacitor with sufficient ripple current rating.

The input capacitor's maximum RMS capacitor current is given by:

$$I_{RMS} \approx I_{MAX} \frac{\sqrt{(V_{IN} - V_{OUT})V_{OUT}}}{V_{IN}}$$

Where the maximum average output current I_{MAX} equals the peak current I_{LM} minus half peak-to-peak ripple current, $I_{MAX} = I_{LM} - I_L/2$.

This formula has a maximum at $V_{IN} = 2V_{OUT}$, where $I_{RMS} = I_{OUT}/2$. This simple worst-case condition is commonly used for design because even significant deviations do not offer much relief. Note that ripple current ratings from capacitor manufacturers are often based on only 2000 hours of life which makes it advisable to further derate the capacitor, or choose a capacitor rated at a higher temperature than required. Several capacitors may also be paralleled to meet size or height requirements in the design.

Output Capacitor Selection

The selection of C_{OUT} is driven by the required effective series resistance (ESR). Typically, once the ESR requirement for C_{OUT} has been met, the RMS current rating generally far exceeds the $I_{RIPPLE}(P-P)$ requirement. The output ripple V_{OUT} is determined by

$$\Delta V_{OUT} \approx \Delta I_L \left(ESR + \frac{1}{8C_{OUT}f_{SW}} \right)$$

Where f_{SW} =operating frequency, C_{OUT} =output capacitance and I_L =ripple current in the inductor. For a fixed output voltage, the output ripple is highest at maximum input voltage since I_L increases with input voltage.

At the light load current, the device operates in Power Saving Mode, and the output voltage ripple is independent of the value of the output capacitor. The output ripple is set by the internal comparator thresholds and is also affected by the feedback capacitor C1 in figure2. Large capacitor values can decrease the output ripple, usually a 22pF capacitor is sufficient for most applications.

When the input and output ceramic capacitors are chosen, choose the X5R or X7R dielectric formulations. These dielectrics have the best temperature and voltage characters have the best temperature and voltage characteristics of all the ceramics for a given value and size.

Output Voltage Setting

In the adjustable version, the output voltage is set by a resistor divider according to following formula:

$$V_{OUT} = 0.5V \times \left(1 + \frac{R2}{R1} \right)$$

The external resistor divider is connected to the output.

Thermal Considerations

In most applications the AME5248A does not dissipate much heat due to its high efficiency. But, in applications where the AME5248A is running at high ambient temperature with low supply voltage and high duty cycles, such as in dropout, the heat dissipated may exceed the maximum junction temperature of the part. If the junction temperature reaches approximately 160 °C, both power switches will be turned off and the SW node will become high impedance. To avoid the AME5248A from exceeding the maximum junction temperature, the user will need to do some thermal analysis. The goal of the thermal analysis is to determine whether the power dissipated exceeds the maximum junction temperature of the part. The temperature rise is given by:

$$TR = (PD) \times \theta_{JA}$$

Where PD is the power dissipated by the regulator and θ_{JA} is the thermal resistance from the junction of the die to the ambient temperature.

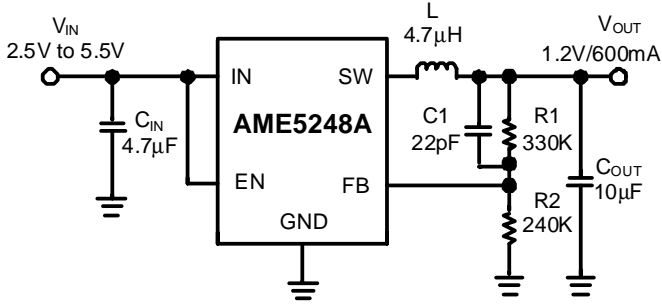
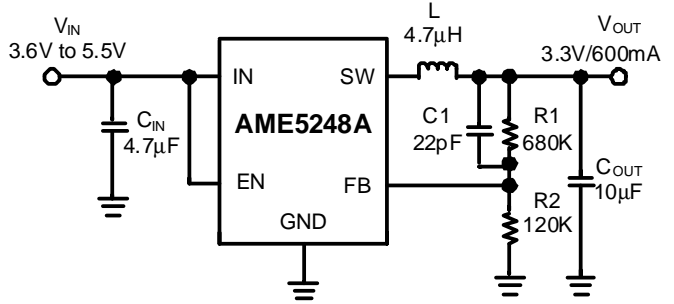
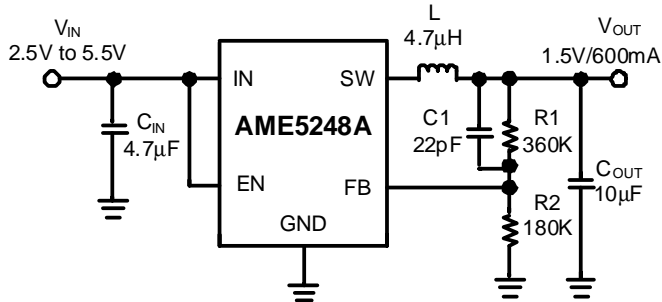
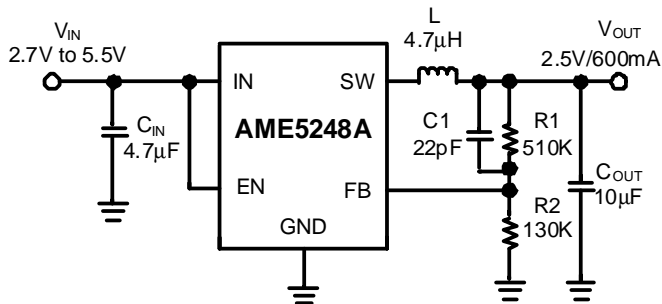
■ Typical Application

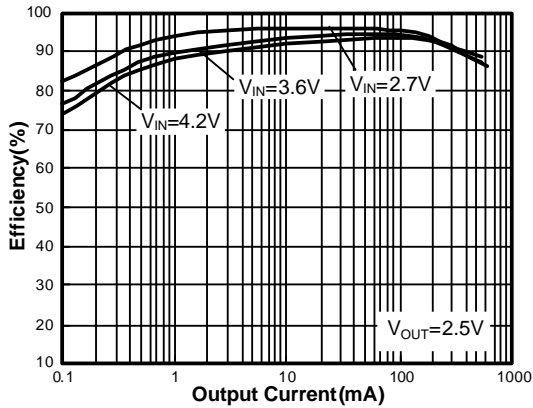
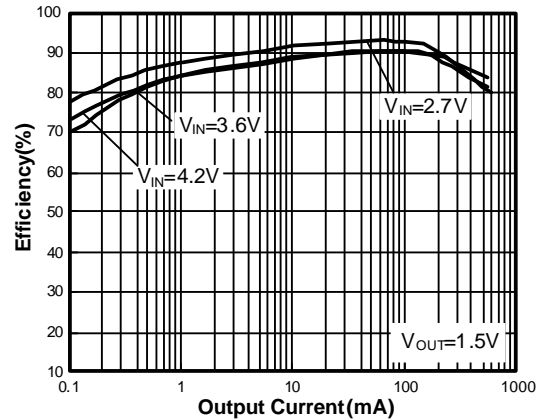
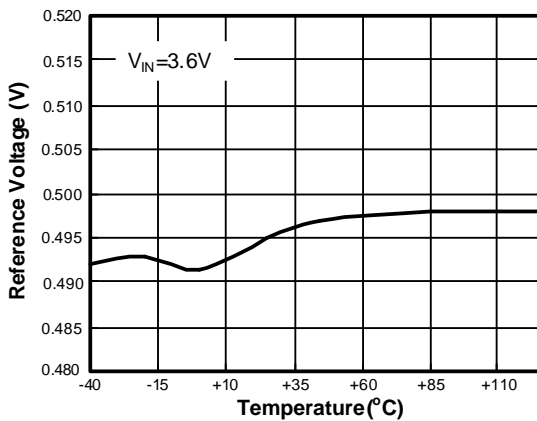
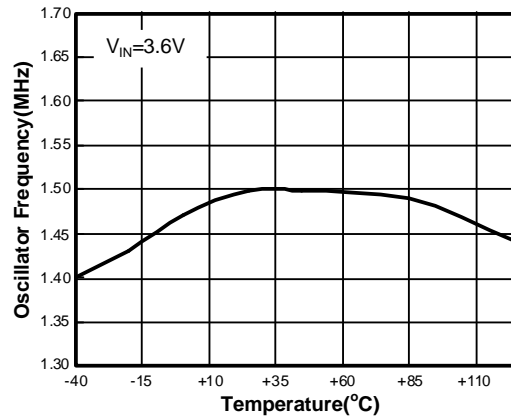
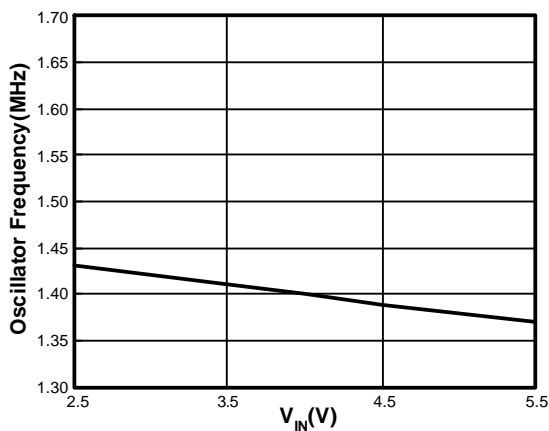
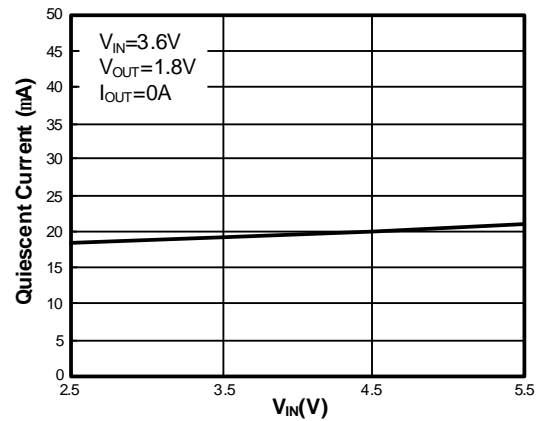
Figure 4. AME5248A with 1.2V Output

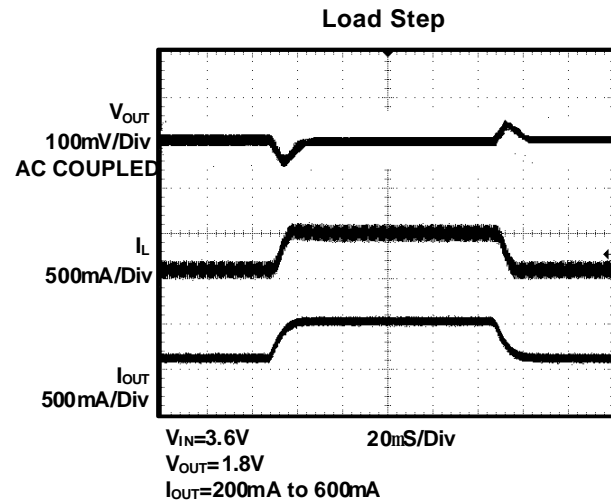
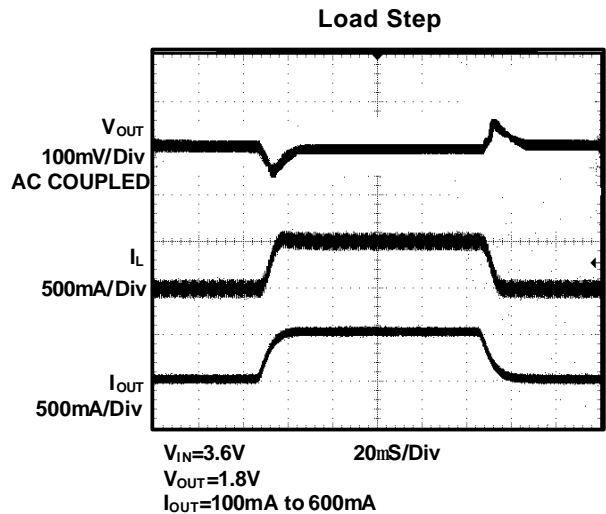
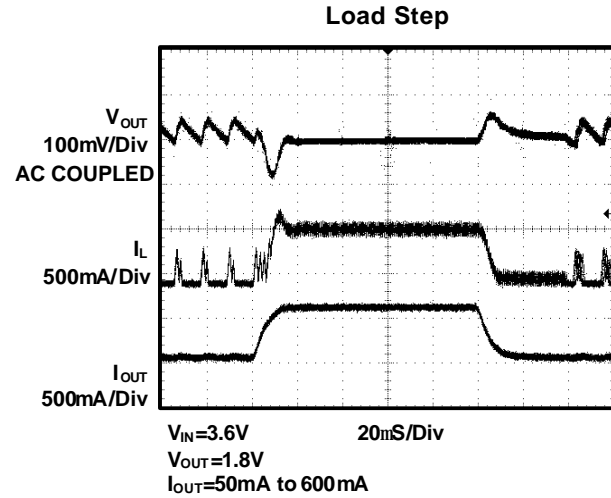
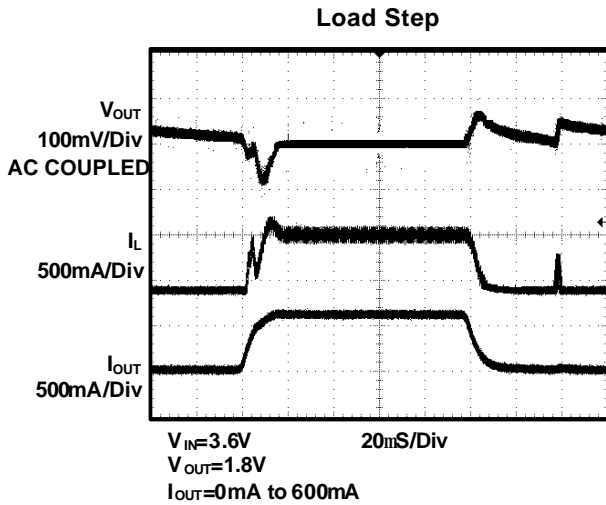
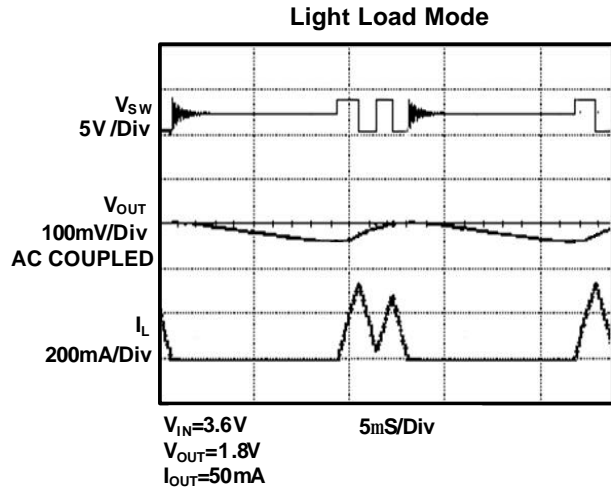
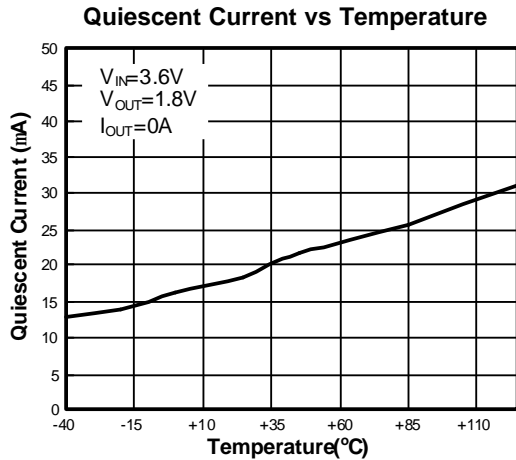
Figure 7. AME5248A with 3.3V Output

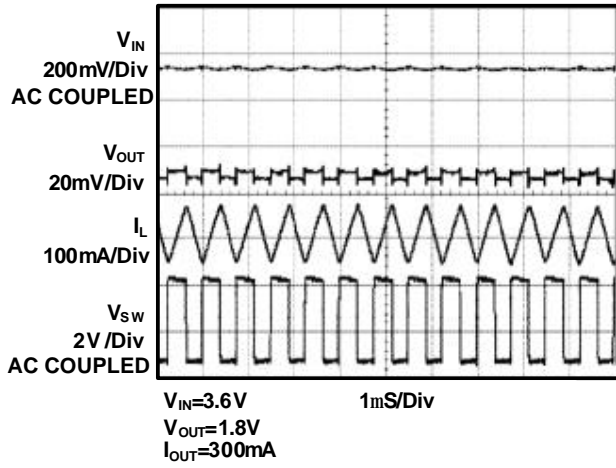
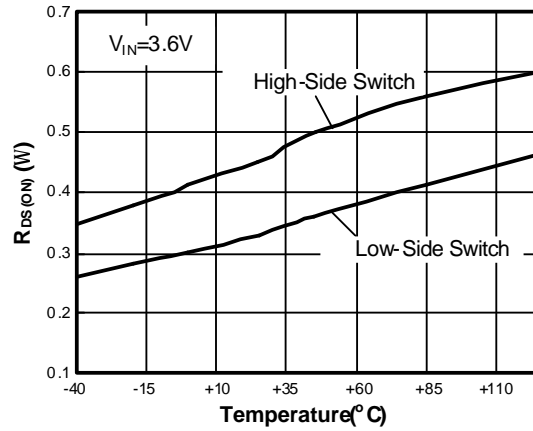
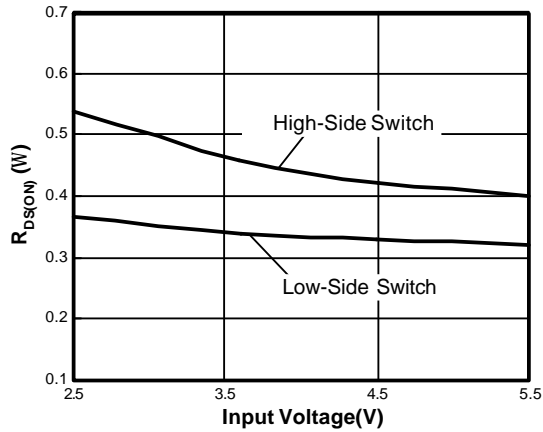
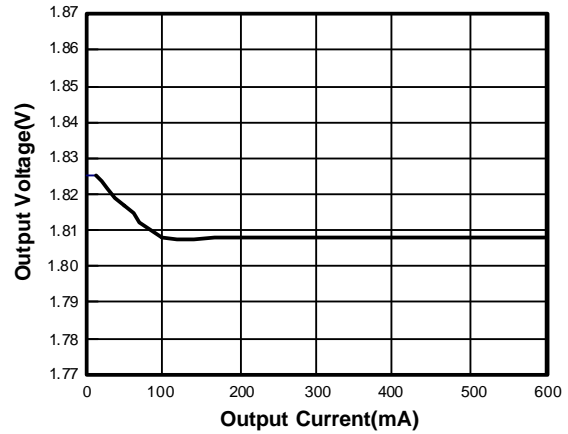
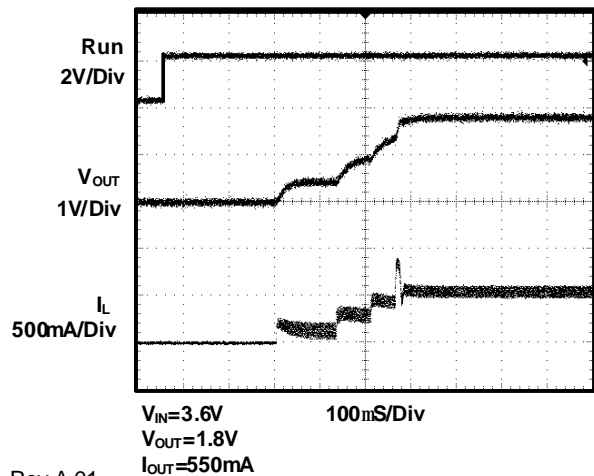
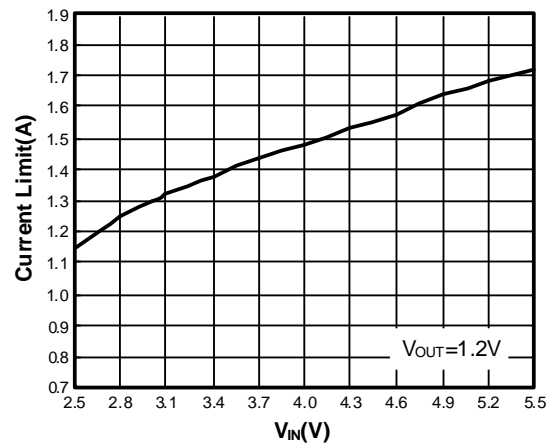
Figure 5. AME5248A with 1.5V Output

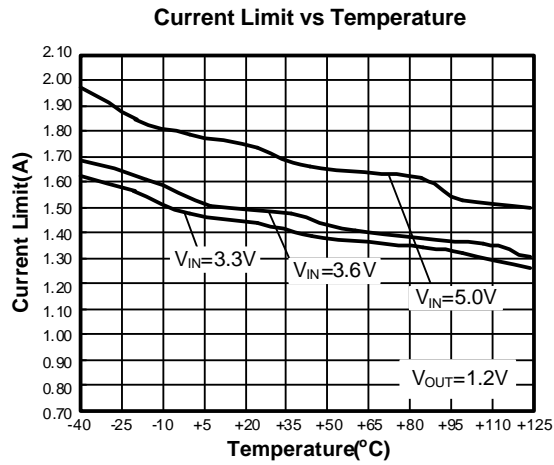
Figure 6. AME5248A with 2.5V Output

Efficiency vs Output Current

Efficiency vs Output Current

Reference Voltage vs Temperature

Oscillator Frequency vs Temperature

Oscillator Frequency vs Supply Voltage

Quiescent Current vs Input Voltage



Stead State Test

 $R_{DS(ON)}$ vs Temperature

 $R_{DS(ON)}$ vs Input Voltage

Output Voltage vs Output Current

Start Up From Shutdown

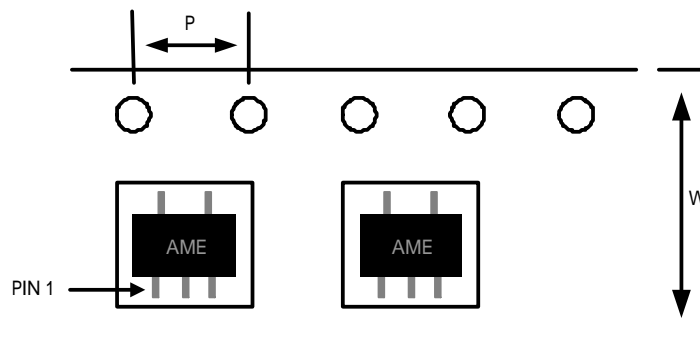
Current Limit vs V_{IN}



■ Date Code Rule

Month Code	
1: January	7: July
2: February	8: August
3: March	9: September
4: April	A: October
5: May	B: November
6: June	C: December

Marking						Year
A	A	A	M	X	X	xxx0
A	A	A	M	X	<u>X</u>	xxx1
A	A	A	M	<u>X</u>	X	xxx2
A	A	A	M	<u>X</u>	<u>X</u>	xxx3
A	A	A	<u>M</u>	X	X	xxx4
A	A	A	<u>M</u>	X	<u>X</u>	xxx5
A	A	A	<u>M</u>	<u>X</u>	X	xxx6
A	A	A	<u>M</u>	<u>X</u>	<u>X</u>	xxx7
A	A	<u>A</u>	M	X	X	xxx8
A	A	<u>A</u>	M	X	<u>X</u>	xxx9

■ Tape and Reel Dimension
SOT-25

Carrier Tape, Number of Components Per Reel and Reel Size

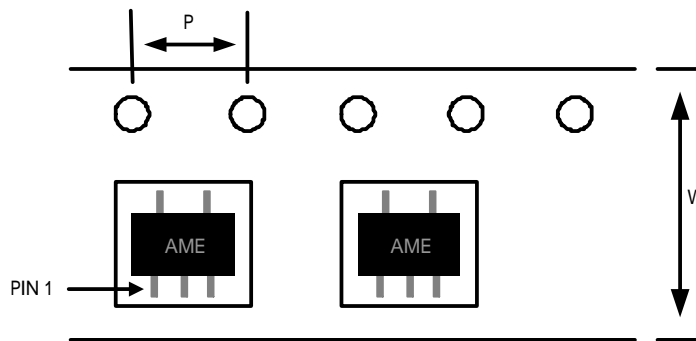
Package	Carrier Width (W)	Pitch (P)	Part Per Full Reel	Reel Size
SOT-25	8.0±0.1 mm	4.0±0.1 mm	3000pcs	180±1 mm

■ Tape and Reel Dimension
TSOT-25

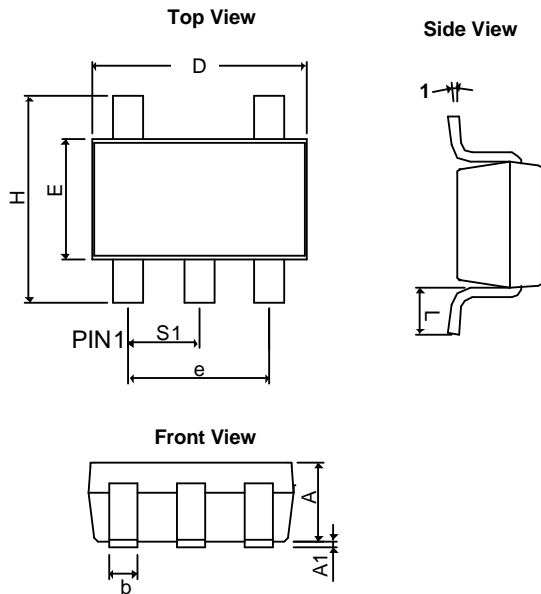
Carrier Tape, Number of Components Per Reel and Reel Size

Package	Carrier Width (W)	Pitch (P)	Part Per Full Reel	Reel Size
TSOT-25	8.0±0.1 mm	4.0±0.1 mm	3000pcs	180±1 mm

■ Package Dimension
SOT-25

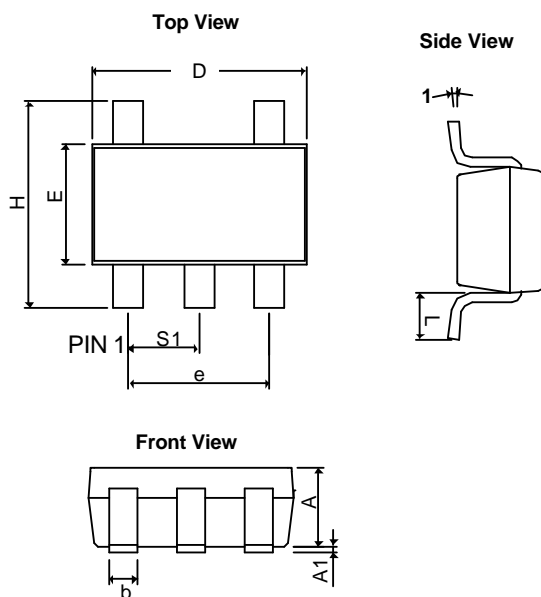
SYMBOLS	MILLIMETERS		INCHES	
	MIN	MAX	MIN	MAX
A	0.90	1.30	0.0354	0.0512
A ₁	0.00	0.15	0.0000	0.0059
b	0.30	0.55	0.0118	0.0217
D	2.70	3.10	0.1063	0.1220
E	1.40	1.80	0.0551	0.0709
e	1.90 BSC		0.07480 BSC	
H	2.60	3.00	0.10236	0.11811
L	0.37BSC		0.0146BSC	
q1	0°	10°	0°	10°
S ₁	0.95BSC		0.0374BSC	

TSOT-25

SYMBOLS	MILLIMETERS		INCHES	
	MIN	MAX	MIN	MAX
A+A ₁	0.90	1.25	0.0354	0.0492
b	0.30	0.50	0.0118	0.0197
D	2.70	3.10	0.1063	0.1220
E	1.40	1.80	0.0551	0.0709
e	1.90 BSC		0.07480 BSC	
H	2.40	3.00	0.0945	0.1181
L	0.35BSC		0.0138BSC	
q1	0°	10°	0°	10°
S ₁	0.95BSC		0.0374BSC	



www.ame.com.tw
E-Mail: sales@ame.com.tw

Life Support Policy:

These products of AME, Inc. are not authorized for use as critical components in life-support devices or systems, without the express written approval of the president of AME, Inc.

AME, Inc. reserves the right to make changes in the circuitry and specifications of its devices and advises its customers to obtain the latest version of relevant information.

© AME, Inc. , June 2009

Document: 3005-DS5248A-A.01

Corporate Headquarter
AME, Inc.

2F, 302 Rui-Guang Road, Nei-Hu District

Taipei 114, Taiwan, R.O.C.

Tel: 886 2 2627-8687

Fax: 886 2 2659-2989