

SOTiny™ LVDS High-Speed Differential Line Receiver

Features

- Meets or Exceeds the Requirements of ANSI TIA/EIA-644-1995 Standard
- Signaling rates up to 400 Mbps
- Interfaces to LVDS, LVPECL
- Bus-Terminal ESD exceeds 10kV
- Differential Input Voltage Threshold less than 100mV
- Typical Propagation Delay Times of 2.6ns
- Typical Power Dissipation of 40mW @200 MHz
- Low Voltage TTL (LVTTTL) Level is 5V Tolerant
- Open-Circuit Fail Safe
- Output are High Impedance with $V_{CC} < 1.5V$
- Integrated 110-ohm Line Termination Resistor (PI90LVT02)
- Operates from a 3.3V supply
- Input common-mode voltage range 0V–3.2V
- Industrial Temperature Operating Range: –40°C to 85°C
- Packages: 5-pin space-saving SOT-23 (T)

Description

The PI90LV02 and PI90LVT02 are single differential line receivers that use low-voltage differential signaling (LVDS) to support data rates up to 400 Mbps. These products are designed for applications requiring high-speed, low-power consumption, low-noise generation, and a small package.

A differential input signal (350mV) is translated by the device to a 3.3V CMOS output level. The PI90LVT02 integrates the terminating resistor while the PI90LV02 requires an external resistor.

Applications

Applications include point-to-point and multi-drop baseband data transmissions over impedance media of approximately 100-ohms. The transmission media can be printed circuit board traces, backplanes, or cables.

The PI90LV02 and PI90LVT02 and companion line drivers (PI90LV01 and PI90LVB01) provide new alternatives to RS-232, PECL, and ECL devices for high-speed, point-to-point interface applications.

Logic Diagram

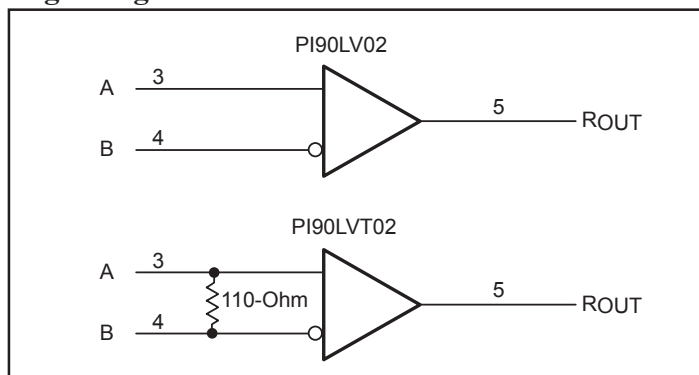

Pinout

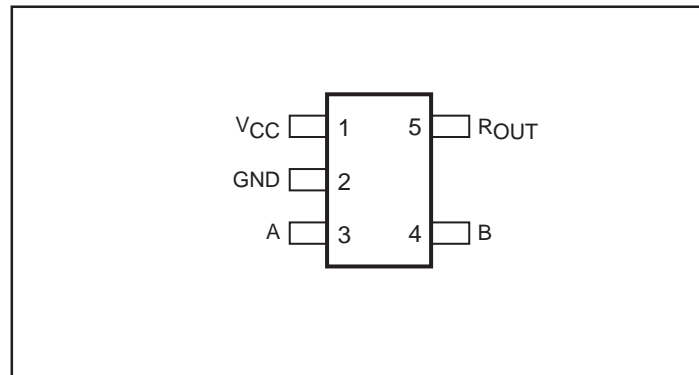

Function Table

| Inputs | Outputs |
|-------------------------|-----------|
| $V_{ID} = V_A - V_B$ | R_{OUT} |
| $V_{ID} > 50mV$ | H |
| $-50mV < V_{ID} < 50mV$ | ? |
| $V_{ID} \leq -50mV$ | L |
| Open | H |

H = high level
 L = low level
 ? = indeterminate

Absolute Maximum Ratings Over Operating Free-Air Temperature

(unless otherwise noted)[†]

| | |
|--|------------------------------|
| Supply Voltage Range, $V_{CC}^{(1)}$ | -0.5V to 4V |
| Voltage Range (A, B, or R_{OUT}) | -0.5 to $V_{CC}+0.5V$ |
| ESD rating (HBM, 1.5K-ohms, 100pF) | $\geq 10KV$ |
| Continuous total power dissipation | See dissipation rating table |
| Storage Temperature Range | -65°C to 150°C |
| Lead Temperature 1.6 mm (1/16 inch) from case for 10 seconds | 250°C |

[†] Stresses beyond those listed under "Absolute Maximum Ratings" may cause permanent damage to the device. These are stress ratings only, and functional operation of the device at these or any other conditions beyond those indicated under "Recommended Operating Conditions" is not implied. Exposure to Absolute-Maximum-Rated conditions for extended periods may affect device reliability.

Notes:

1. All voltage values, except differential I/O bus voltages, are with respect to ground terminal.

Dissipation Rating Table

| Package | $T_A \leq 25^\circ C$ Power Rating | Derating Factor Above $T_A = 25^\circ C^{**}$ | $T_A = 85^\circ C$ Power Rating |
|------------------|------------------------------------|---|---------------------------------|
| 5-Pin SOT-23 (T) | 385mW | 3.1mW/°C | 200mW |

**This is the inverse of the junction-to-ambient thermal resistance when board-mounted (low-K) and with no air flow.

Recommended Operating Conditions

| | Min. | Nom. | Max. | Units |
|---|------|------|----------------------------|-------|
| Supply Voltage, V_{CC} | 3.0 | 3.3 | 3.6 | V |
| Magnitude of differential input voltage, $ V_{ID} $ | 0.1 | | 0.6 | |
| Common-Mode Input Voltage, V_{IC} (See Figure 6) | 0 | | $2.0 - \frac{ V_{ID} }{2}$ | |
| | | | $V_{CC} - 0.8$ | |
| Operating free-air temperature, T_A | -40 | | 85 | °C |

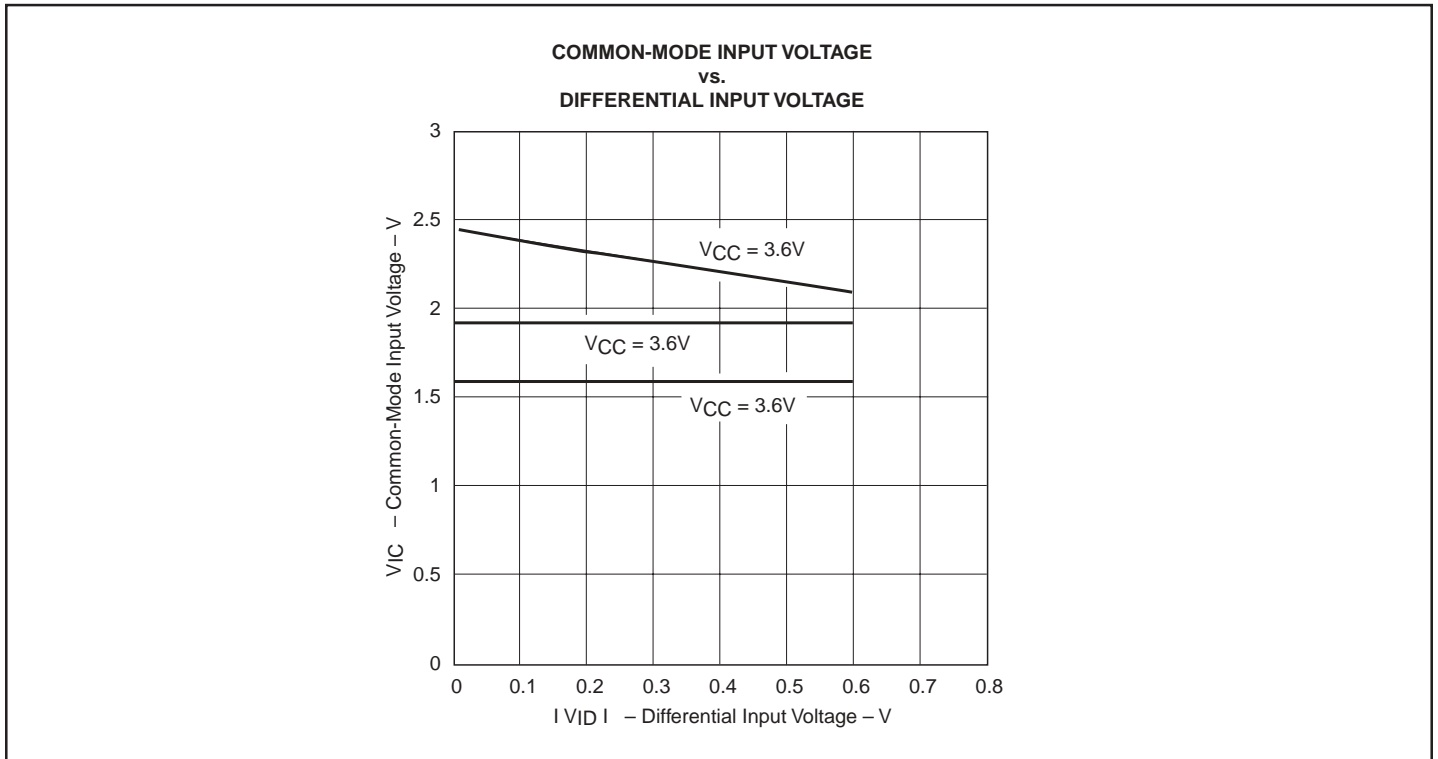

Figure 1. V_{IC} vs. V_{ID} and V_{CC}

Electrical Characteristics, $V_{CC} = 3V$ to $3.6V$ (Over Recommended Operating Conditions, unless otherwise noted).

| Symbol | Parameter | Test Conditions | Min. | Typ. ⁽¹⁾ | Max. | Units | |
|--------------|---|-------------------------|--|---------------------|------|----------|---------|
| V_{ITH+} | Positive-going differential input voltage threshold | See Figure 2, & Table 1 | | | 100 | mV | |
| V_{ITH-} | Negative-going differential input voltage threshold | | -100 | | | | |
| V_{OH} | High-level output voltage | $I_{OH} = -8mA$ | 2.4 | 3 | | V | |
| V_{OL} | Low-level output voltage | $I_{OL} = 8mA$ | | 0.25 | 0.4 | | |
| I_{CC} | Supply current | No load, Steady state | | 4 | 7 | mA | |
| I_I | Input current (A or B inputs) | LV02 | $V_I = 0V$ | | | ± 20 | μA |
| | | LVT02 | $V_I = 0V$, Other input open | | | ± 40 | |
| | | LV02 | $V_I = 2.4V$ or $V_{CC} - 0.8$ | -1.2 | | | |
| | | LVT02 | $V_I = 2.4V$, Other input open | -2.4 | | | |
| I_{ID} | High-level input current ($I_{IA} - I_{IB}$) | LV02 | $V_{IA} = 0V, V_{IB} = 0.1V$ $V_{IA} = 2.4V, V_{IB} = 2.3V$ | | | ± 2 | mA |
| | | LVT02 | $V_{IA} = 2.4V, V_{IB} = 2.3V$ | 1.5 | 1.8 | 2.2 | |
| $I_{I(OFF)}$ | Power-off input current (A or B inputs) | LV02 | $V_{CC} = 0V, V_I = 2.4V$ | | | 20 | μA |
| | | LVT02 | $V_{CC} = 0V, V_I = 2.4V$, Other input open | | | 40 | |

Receiver Switching Characteristics, $V_{CC} = 3V$ to $3.6V$ (Over Recommended Operating Conditions, unless noted).

| Symbol | Parameter | Test Conditions | Min. | Typ. ⁽¹⁾ | Max. | Units |
|-------------|---|--------------------------------|------|---------------------|------|-------|
| t_{PLH} | Propagation delay time, low-to-high level output | $C_L = 10pF$, See Figure 3 | 1.3 | 2.1 | 3.2 | ns |
| t_{PHL} | Propagation delay time, high-to-low level output | | 1.3 | 2.0 | 3.2 | |
| t_r | Output signal rise time | | | 0.7 | 1.4 | |
| t_f | Output signal fall time | | | 0.7 | 1.4 | |
| $t_{sk(p)}$ | Pulse skew ($ t_{PHL} - t_{PLH} $) ⁽²⁾ | | | 0.1 | 0.5 | |
| t_{PZH} | Propagation delay time, high-level-to-high-impedance output | See Figure 4 | | 1.5 | 3.1 | |
| t_{PZL} | Propagation delay time, low-level-to-low-impedance output | | | 4.0 | 6.0 | |
| t_{PHZ} | Propagation delay time, high-impedance-to-high-level output | | | 2.5 | 3.5 | |
| t_{PLZ} | Propagation delay time, low-impedance-to-high-level output | | | 6.0 | 7.6 | |

Notes:

1. All typical values are at 25°C and with a 3.3V supply
2. $t_{sk(p)}$ is the magnitude of the time difference between the high-to-low and low-to-high propagation delay times at an output.

Parameter Measurement Information

Figure 2. Receiver Voltage Definitions

Table 1. Receiver Minimum and Maximum Input Threshold Test Voltages

| Applied Voltages (V) | | Resulting Differential Input Voltage (mV) | Resulting Common-Mode Input Voltage (V) |
|----------------------|-----------------|---|---|
| V _{IA} | V _{IB} | V _{ID} | V _{IC} |
| 1.25 | 1.20 | 50 | 1.2 |
| 1.15 | 1.20 | -50 | 1.2 |
| 2.4 | 2.35 | 50 | 2.35 |
| 2.3 | 2.35 | -50 | 2.35 |
| 0.05 | 0 | 50 | 0.05 |
| 0 | 0.05 | -50 | 0.05 |
| 1.5 | 0.9 | 600 | 1.2 |
| 0.9 | 1.5 | -600 | 1.2 |
| 2.4 | 1.8 | 600 | 2.1 |
| 1.8 | 2.4 | -600 | 2.1 |
| 0.6 | 0 | 600 | 0.3 |
| 0 | 0.6 | -600 | 0.3 |

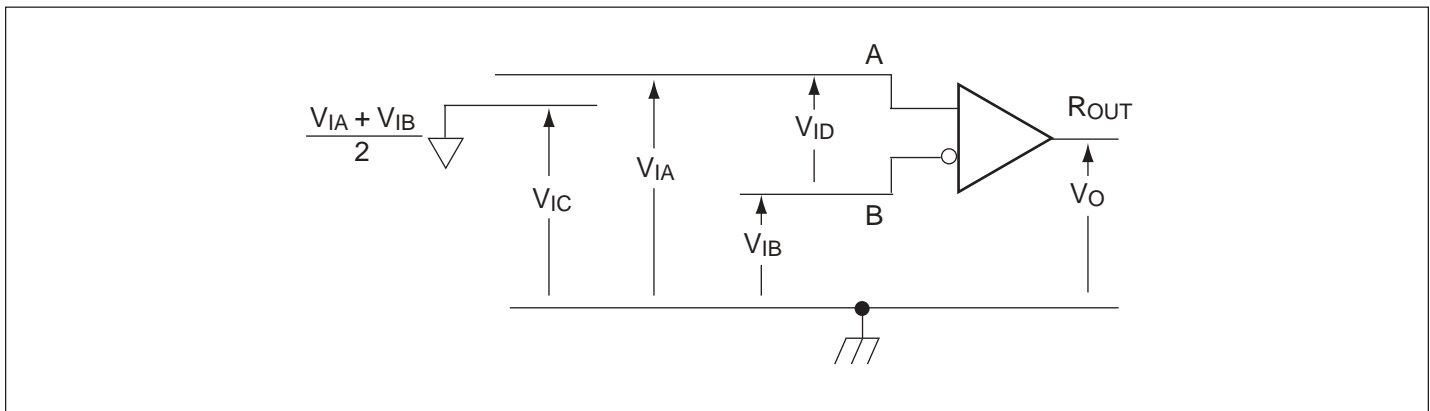
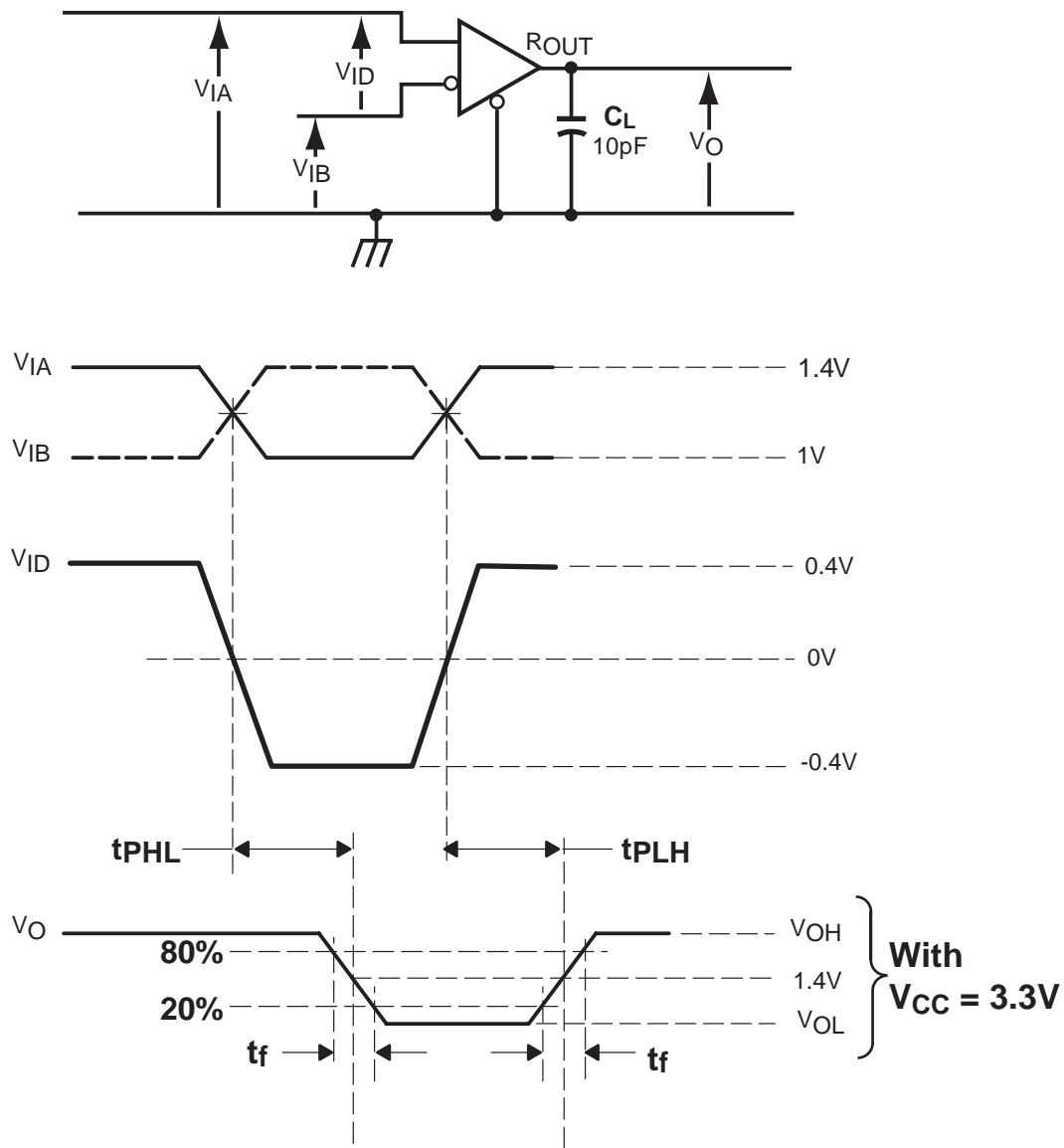

Note A: All input pulses are supplied by a generator having the following characteristics:
 t_r or $t_f \leq 1ns$, pulse repetition rate (PRR) = 50 Mpps, pulse width = $10 \pm 0.2ns$.
 C_L includes instrumentation and fixture capacitance within 0.06m of the D.U.T.

Note B: To verify input max signalling rate, the input signal transition time (t_r/t_f) should not exceeds 1.25ns.

Figure 3. Timing Test Circuit and Waveforms

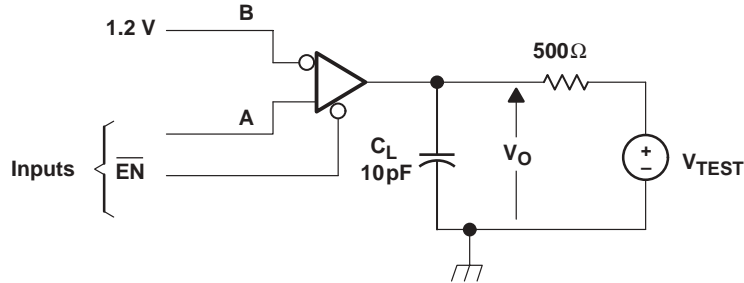

NOTE A: All input pulses are supplied by a generator having the following characteristics: t_r or $t_f \leq 1$ ns, pulse repetition rate (PRR) = 0.5 Mpps, pulse wide = 500 ± 10 ns. C_L includes instrumentation and fixture capacitance within 0.06m of the D.U.T.

NOTE B: To verify input max signalling rate, the input signal transition time (t_r/t_f) should not exceed 1.25 ns.

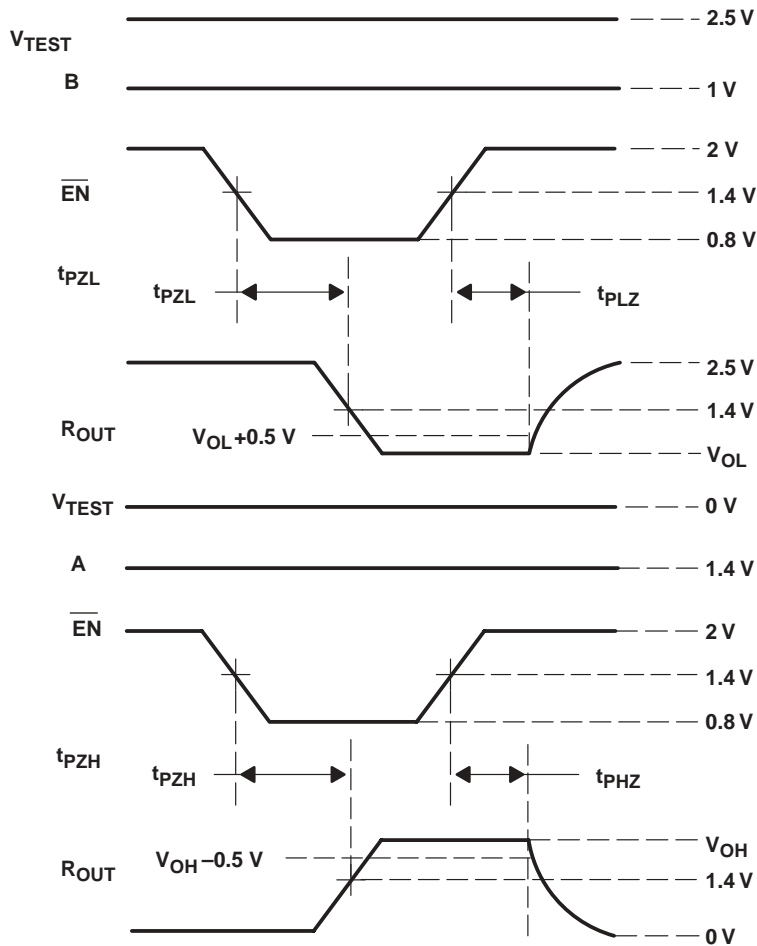

Figure 4. Enable/Disable Time Test Circuit and Waveforms

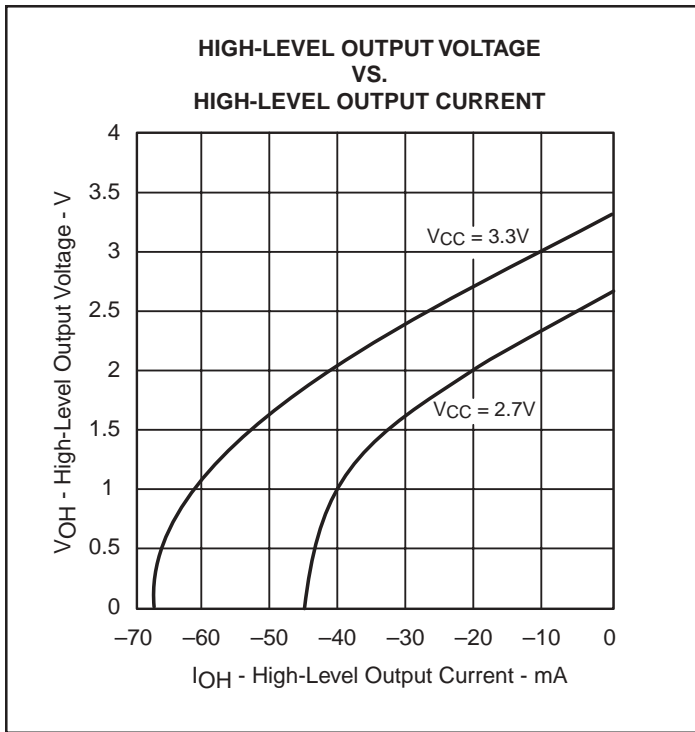

Figure 5

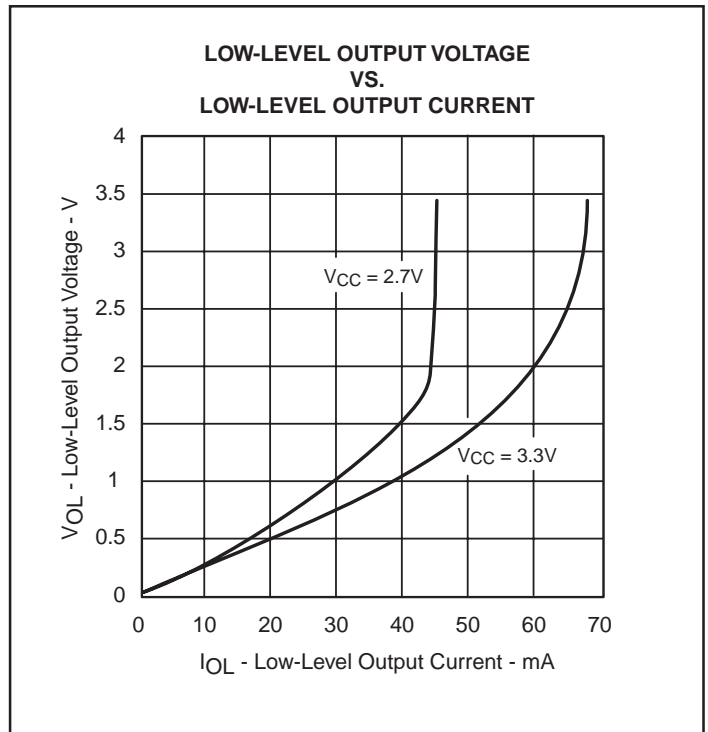

Figure 6

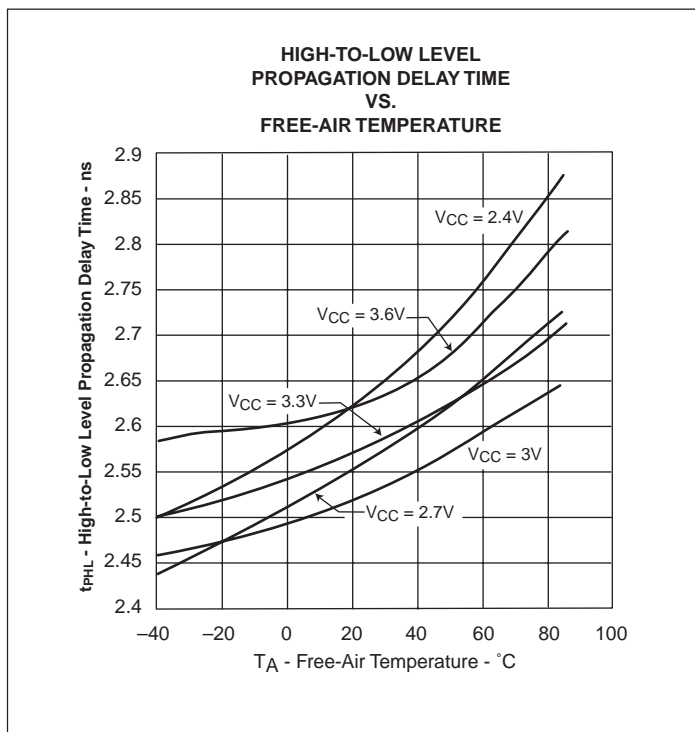

Figure 7

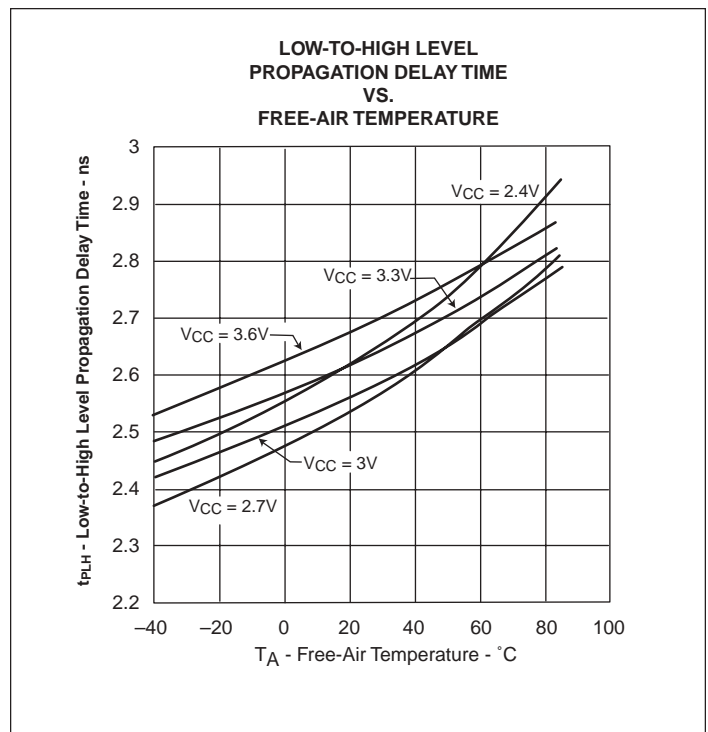
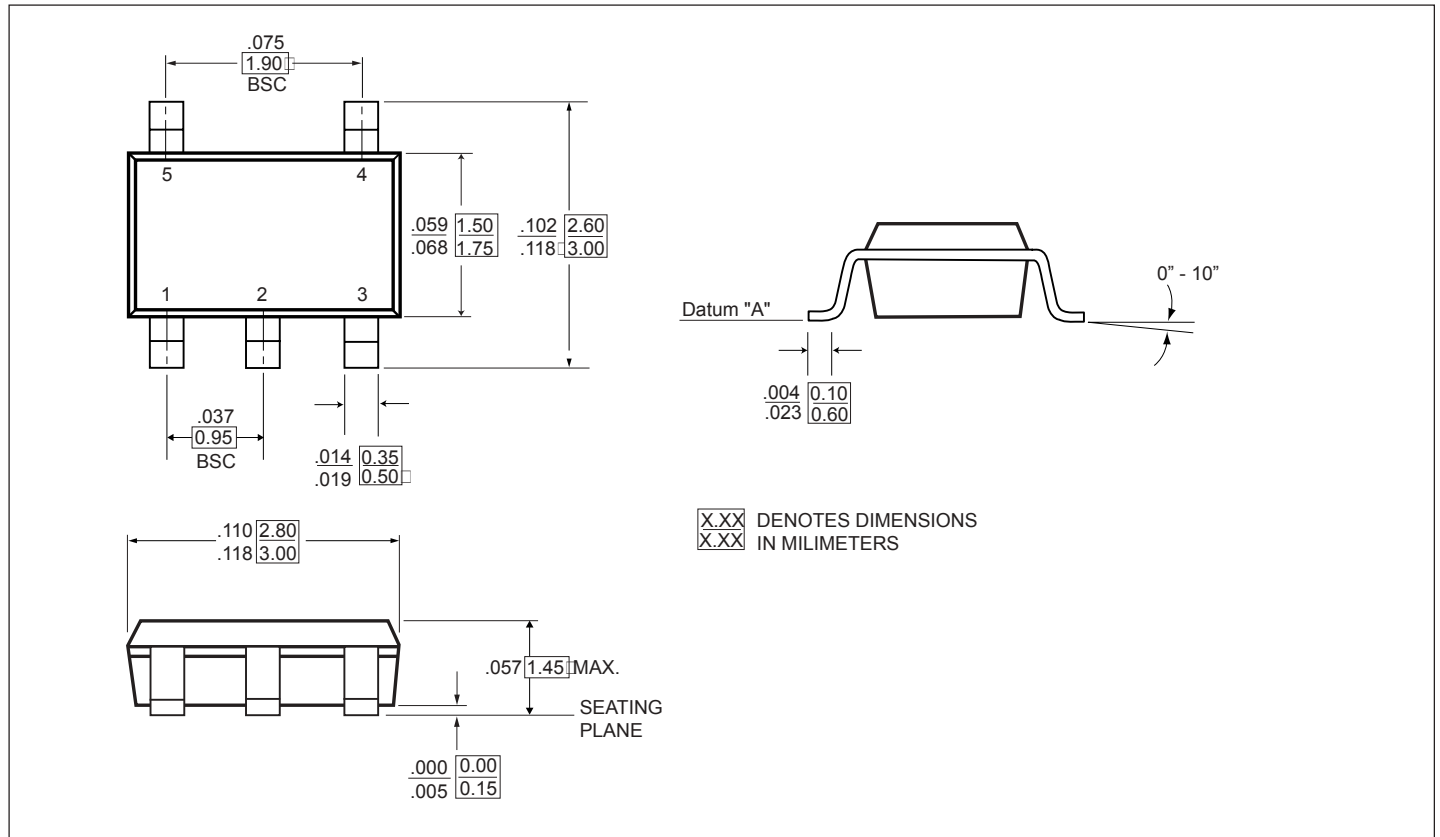

Figure 8

5-Pin SOT-23 (T) Package



Ordering Information

| Part | Top Marking | Pin - Package | Temperature |
|-------------|-------------|---------------|---------------|
| PI90LV02TX | R02 | 5-Pin SOT-23 | -40°C to 85°C |
| PI90LVT02TX | RT2 | | |