

Features

- XTREMELY Low Jitter
- Low Cost
- XPRESS Delivery
- Frequency Resolution to six decimal places
- Stabilities to ± 20 PPM
- -20 to +70°C or -40 to +85°C operating temperatures
- Tri-State Enable / Disable Feature
- Industry Standard Package, Footprint & Pin-Out
- Fully RoHS compliant
- Gold over Nickel Termination Finish
- Serial ID with Comprehensive Traceability



Applications

- ANY application requiring an oscillator
- SONET
- Ethernet
- Storage Area Network
- Broadband Access
- Microprocessors / DSP / FPGA
- Industrial Controllers
- Test and Measurement Equipment
- Fiber Channel

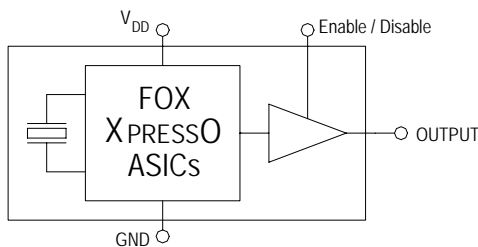

For more information -- Click on the drawing

Description

The Fox XPRESSO Crystal Oscillator is a breakthrough in configurable Frequency Control Solutions. XPRESSO utilizes a family of proprietary ASICs, designed and developed by Fox, with a key focus on noise reduction technologies.

The 3rd order Delta Sigma Modulator reduces noise to the levels that are comparable to traditional Bulk Quartz and SAW oscillators. The ASICs family has ability to select the output type, input voltages, and temperature performance features.

With the XPRESS lead-time, low cost, low noise, wide frequency range, excellent ambient performance, XpressO is an excellent choice over the conventional technologies.

Finished XPRESSO parts are 100% final tested.

Contents

| | page |
|---|---------|
| Model Selection & Part Number Guide | 2 |
| Electrical Characteristic | 2 |
| Absolute Maximums | 3 |
| Output Wave Characteristics | 3 |
| Phase Noise | 4 |
| Jitter | 4 |
| Pin Assignment | 5 |
| Recommended Circuit | 5 |
| Re-Flow | 5 |
| Mechanical Drawing and Pad Layout | 6 |
| Tape and Reel Specification | 7 |
| Label | 7 |
| Traceability – LOT Number & Serial Identification | 8 |
| RoHS Material Declaration | 9 |
| SGS Report | 10 & 11 |
| Mechanical Test | 12 |
| Burn-In Test | 12 |
| MTTF / FITS calculations | 13 |
| Other XPRESSO Links | 14 |
| Fox Contact Information | 14 |

Model Selection Guide & Fox Part Number

STEP #1: Customer selects the Model Description and provides to Fox Customer Service

Model Description

FXO - HC726R - 106.25 Frequency (in MHz)
Resolutions to 6 places past the decimal point

| | | | | | |
|---|--------------------|---------------|-----------|---------------|------------------------|
| H = HCMOS | C = Ceramic | 5 = 5 x 3.2mm | 3 = 3.3 V | 0 = ± 100 PPM | blank = -20°C to +70°C |
| L = LVDS | Q = Quartz | 7 = 7 x 5mm | 2 = 2.5 V | 5 = ± 50 PPM | R = -40°C to +85°C |
| P = LVPECL | | | | 6 = ± 25 PPM | |
| M = LVDS (pin 2 E/D) | | | | 8 = ± 20 PPM | |
| Q = LVPECL (pin 2 E/D) | | | | (-20 ~ +70°C) | |
| X = HCMOS (comp 2 nd Output) | | | | | |

STEP #2: The Fox Customer Service team provides a customer specific Part Number for use on their Bill Of Materials (BOM).

Fox Part Number (The assigned Fox Part Number must be on the BOM – not the above Model Description)
 (This will ensure receipt of the proper part)

The 1st Field

Product Code #
 767 = FXO-HC5
768 = FXO-HC7
 770 = FXO-LC5
 771 = FXO-LC7
 773 = FXO-PC5
 774 = FXO-PC7

768 - 106.25 - 20

The 2nd Field
 The Customer's Frequency

The 3rd Field

Fox Internally Generated Number
 (If any specification changes, the last digits change)
 (The same specs for a different customer also changes the last digits)

This example, FXO-HC726R-106.25 = HCMOS Output, Ceramic 7 x 5mm Package, 2.5V, ±25 PPM Stability, -40 to +85°C Temperature Range, at 106.25 MHz

Electrical Characteristics

| Parameters | Symbol | Condition | Maximum Value (unless otherwise noted) |
|----------------------------------|------------------|-------------------------------|---|
| Frequency Range | F _O | | 0.750 to 180.000 MHz |
| Frequency Stability ¹ | | | 100, 50, 25, & 20 ppm |
| Temperature Range | T _O | Standard operating | -20°C to +70°C |
| | T _{STG} | Optional operating Storage | -40°C to +85°C -55°C to +125°C |
| Supply Voltage | V _{DD} | Standard | 2.5 V ± 5% |
| Input Current (@ 15pF LOAD) | I _{DD} | 0.75 ~ 20 MHz | 22 mA |
| | | 20+ ~ 50 MHz | 25 mA |
| | | 50+ ~ 100 MHz | 29 mA |
| | | 100+ ~ 130 MHz | 32 mA |
| | | 130+ ~ 160 MHz | 35 mA |
| | | 160+ ~ 180 MHz | 37 mA |
| Output Load | HCMOS | Standard | 15 pF |
| Start-Up Time | T _S | | 10 mS |
| Output Enable / Disable Time | | | 100 nS |
| Moisture Sensitivity Level | MSL | JEDEC J-STD-20 | 1 |
| Termination Finish | | | Au |

¹ Note 1 – Stability is inclusive of 25°C tolerance, operating temperature range, input voltage change, load change, aging, shock and vibration.

Absolute Maximum Ratings *(Useful life may be impaired. For user guidelines only, not tested)*

| Parameters | Symbol | Condition | Maximum Value (unless otherwise noted) |
|-----------------------|------------|------------------|---|
| Input Voltage | V_{DD} | | -0.5V to +5.0V |
| Operating Temperature | T_{AMAX} | | -55°C to +105°C |
| Storage Temperature | T_{STG} | | -55°C to +125°C |
| Junction Temperature | | | 150°C |
| ESD Sensitivity | HBM | Human Body Model | > 1 kV |

Output Wave Characteristics

| Parameters | Symbol | Condition | Maximum Value (unless otherwise noted) |
|-------------------------------------|----------|------------------------------------|---|
| Output LOW Voltage | V_{OL} | 0.75 to 160 MHz 160+ to 180 MHz | 10% V_{DD} 20% V_{DD} |
| Output HIGH Voltage | V_{OH} | 0.75 to 160 MHz 160+ to 180 MHz | 90% V_{DD} MIN 80% V_{DD} MIN |
| Output Symmetry (See Drawing Below) | | @ 50% V_{DD} Level | 45% ~ 55% |
| Output Enable (PIN # 1) Voltage | V_{IH} | | > 70% V_{DD} |
| Output Disable (PIN # 1) Voltage | V_{IL} | | < 30% V_{DD} |
| Cycle Rise Time (See Drawing Below) | T_R | 0.75 to 160 MHz 160+ to 180 MHz | 3.5 nS (10%~90%) 2.5 nS (20%~80%) |
| Cycle Fall Time (See Drawing Below) | T_F | 0.75 to 160 MHz 160+ to 180 MHz | 3.5 nS (90%~10%) 2.5 nS (80%~20%) |

If 30% to 70% times are used, Rise and Fall times change to 2 nS from 0.75 to 180MHz
 If 20% to 80% times are used, Rise and Fall times change to 2.5 nS from 0.75 to 160MHz

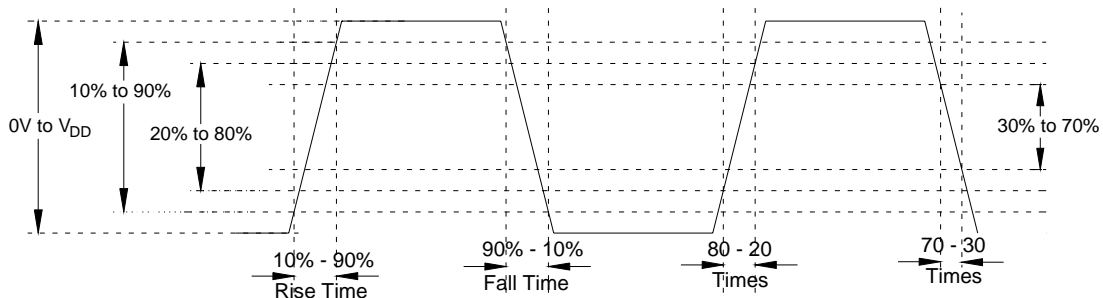
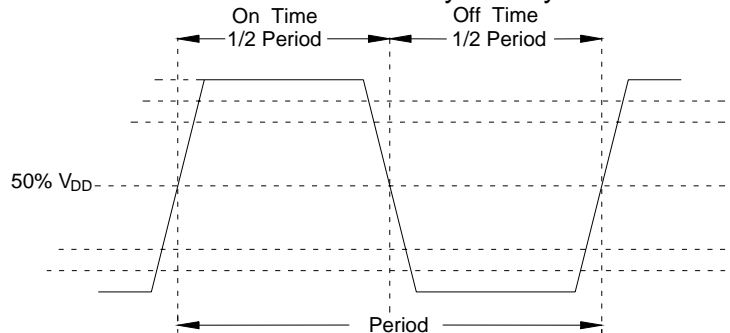
Rise Time / Fall Time Measurements

Oscillator Symmetry

Ideally, Symmetry should be 50/50 -- Other expressions are 45/55 or 55/45

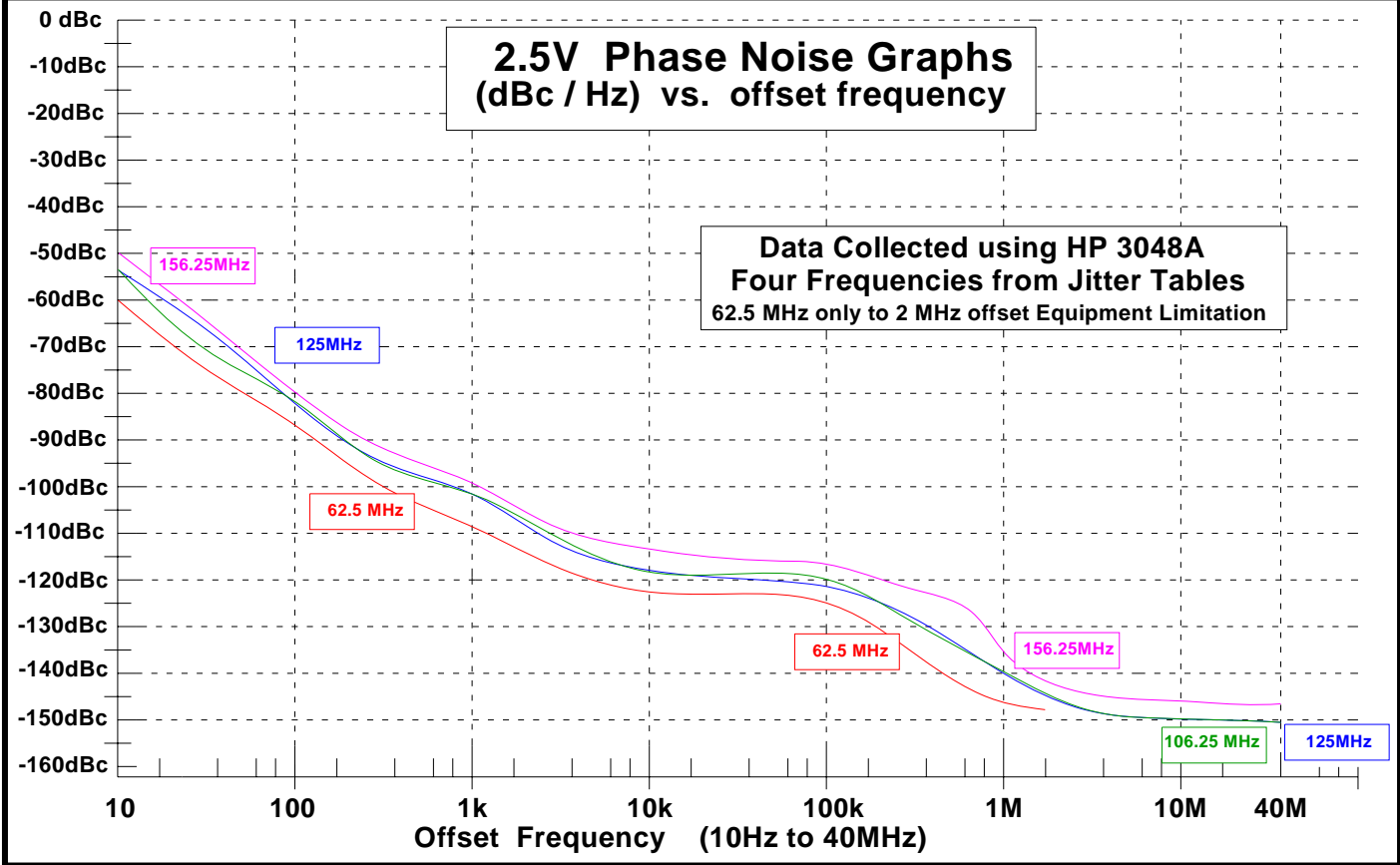
Phase Noise



Jitter is frequency dependent. Below are typical values at select frequencies.

| Phase Jitter & Time Interval Error (TIE) | | | |
|---|----------------------------------|---------------------------------------|--------|
| Frequency | Phase Jitter (12kHz to 20MHz) | TIE (Sigma of Jitter Distribution) | Units |
| 62.5 MHz | 2.1 | 3.1 | pS RMS |
| 106.25 MHz | 1.2 | 3.5 | pS RMS |
| 125 MHz | 1.1 | 2.7 | pS RMS |
| 156.25 MHz | 0.8 | 3.7 | pS RMS |

Phase Jitter is integrated from HP3048 Phase Noise Measurement System; measured directly into 50 ohm input; $V_{DD} = 2.5V$.

TIE was measured on LeCroy LC684 Digital Storage Scope, directly into 50 ohm input, with Amherst M1 software; $V_{DD} = 2.5V$.

Per **MJSQ spec** (Methodologies for Jitter and Signal Quality specifications)

| Random & Deterministic Jitter Composition | | | |
|--|-------------------------|--------------------------------|-------------------------------------|
| Frequency | Random (Rj) (pS RMS) | Deterministic (Dj) (pS P-P) | Total Jitter (Tj) (14 x Rj) + Dj |
| 62.5 MHz | 1.3 | 8.4 | 27.6 pS |
| 106.25 MHz | 1.4 | 8.3 | 27.7 pS |
| 125 MHz | 1.3 | 6.7 | 25.6 pS |
| 156.25 MHz | 1.4 | 9.7 | 29.5 pS |

Rj and Dj, measured on LeCroy LC684 Digital Storage Scope, directly into 50 ohm input, with Amherst M1 software.

Per **MJSQ spec** (Methodologies for Jitter and Signal Quality specifications)



Pin Description and Recommended Circuit

| Pin # | Name | Type | Function |
|-------------|------------------------------|--------|---|
| 1 | E / D ¹ | Logic | Enable / Disable Control of Output (0 = Disabled) |
| 2 | GND | Ground | Electrical Ground for V _{DD} |
| 3 | Output | Output | HCMOS Oscillator Output |
| 4 | V _{DD} ² | Power | Power Supply Source Voltage |
| Test Points | N. C. | Hi Z | No Connection (Factory Use ONLY) |

NOTES:

- ¹ Includes pull-up resistor to V_{DD} to provide output when the pin (1) is No Connect.
- ² Installation should include a 0.01μF bypass capacitor placed between V_{DD} (Pin 4) and GND (Pin 2) to minimize power supply line noise.

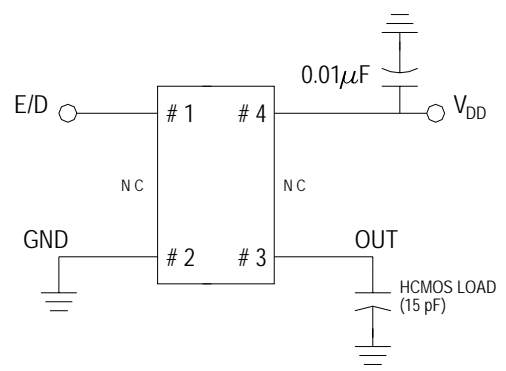
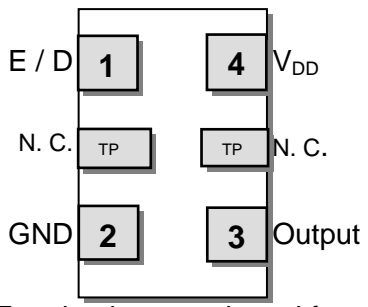

Terminations as viewed from the Top

NOTE: XPRESSO HCMOS XOs are designed to fit on Industry Standard, 4 pad layouts

Enable / Disable Control

| Pin # 1 (state) | Output (Pin # 3) |
|---|------------------|
| OPEN (No Connection) | ACTIVE Output |
| "1" Level V _{IH} > 70% V _{DD} | ACTIVE Output |
| "0" Level V _{IL} < 30% V _{DD} | High Impedance |

Soldering Reflow Profile (2 times Maximum at 260°C for 10 seconds MAX)

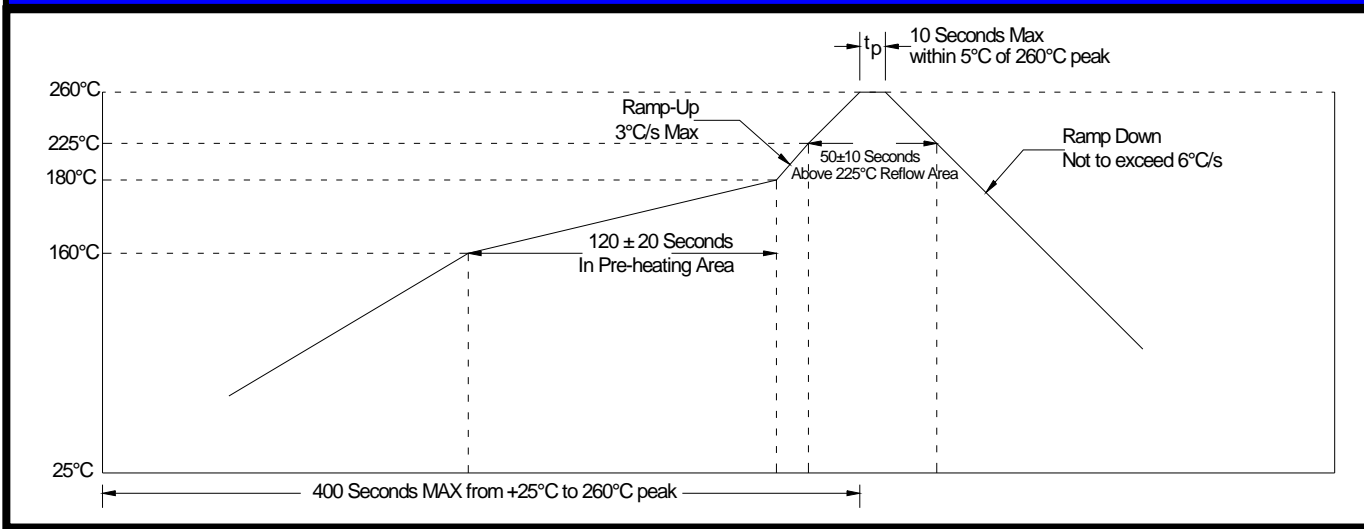

Mechanical Dimensional Drawing & Pad Layout

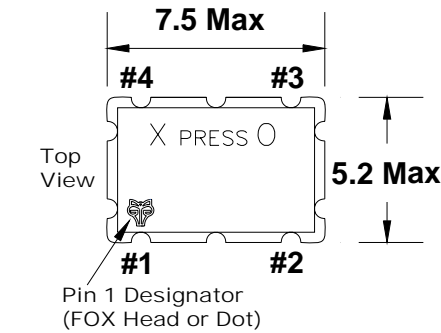

Actual part marking is depicted.

See **Traceability** (pg. 8) for more information

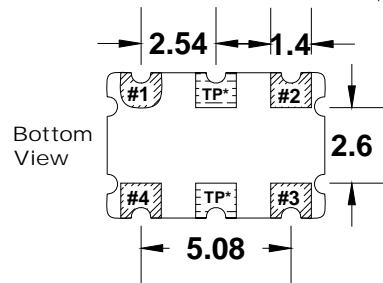
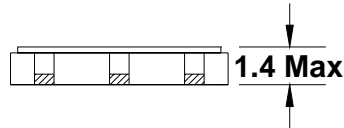

Recommended Solder Pad Layout

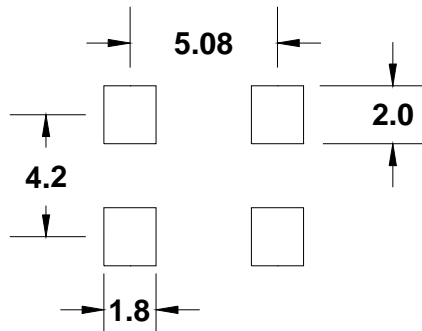

Note: XPRESSO HCMOS XO's are designed to fit or industry standard, 4 pad, layouts.

Pin Connections

- #1) E/D #3 Output
- #2 GND #4 VDD

*TP are test points and are NC

Drawing is for reference to critical specifications defined by size measurements. Certain non-critical visual attributes, such as side castellations, reference pin shape, etc. may vary

Tape and Reel Dimensions

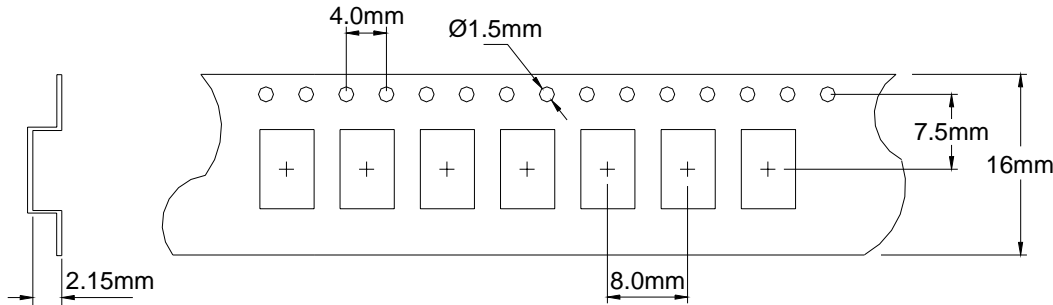

1k Reel Dimensions in mm

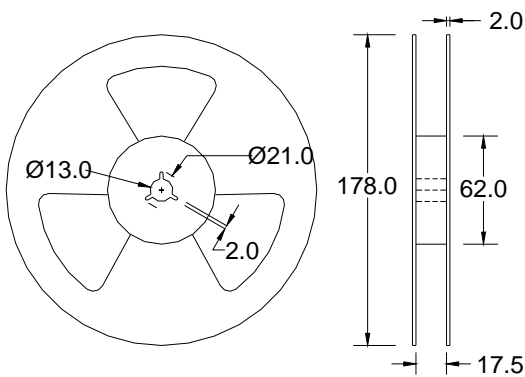

2k Reel Dimensions in mm

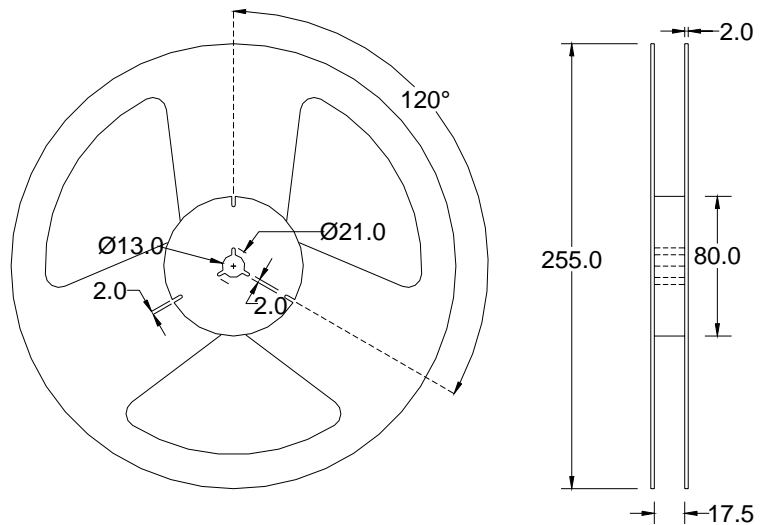

Labeling (Reels and smaller packaging are labeled with the below)

- Fox Part Number: **768-25-151** →
- Quantity: **2000** pieces →
- Description: **FXO-HC726R-25** →
- Date Code: **0745** →
(YYWW 2007 45th wk)
- LOT #: **24435** →
If traceability should become necessary

An additional identification code is contained internally if tracking should ever be necessary

Traceability – LOT Number & Serial Identification

LOT Number

The LOT Number has direct ties to the customer purchase order. The LOT Number is marked on the “Reel” label, and also stored internally on non-volatile memory inside the XPRESSO part. XPRESSO parts that are shipped Tape and Reel, are also placed in an Electro Static Discharge (ESD) bag and will have the LOT Number labeled on the exterior of the ESD bag.

It is recommended that the XPRESSO parts remain in this ESD bag during storage for protection and identification.

If the parts become separated from the label showing the LOT Number, it can be retrieved from inside one of the parts, and the information that can be obtained is listed below:

- Customer Purchase Order Number
- Internal Fox Sales Order Number
- Dates that the XPRESSO part was shipped from the factory
- The assigned customer part number
- The specification that the part was designed for

Serial Identification

The Serial ID is the individualized information about the configuration of that particular XPRESSO part. The Serial ID is unique for each and every XPRESSO part, and can be read by special Fox equipment.

With the Serial ID, the below information can be obtained about that individual, XPRESSO part:

- Equipment that the XPRESSO part was configured on
- Raw material used to configure the XPRESSO part
- Traceability of the raw material back to the foundries manufacturing lot
- Date and Time that the part was configured
- Any optimized electrical parameters based on customer specifications
- Electrical testing of the actual completed part
- Human resource that was monitoring the configuration of the part

Fox has equipment placed at key Fox locations World Wide to read the Lot Identification and Serial Number of any XPRESSO part produced and can then obtain the information from above within 24 hours

RoHS Material Declaration

| | Material Name | Component | Content (mg) | Content (w t %) | (CAS Number) |
|--------------|------------------|--|---------------|-----------------|--------------|
| Cover | Kovar | Nickel (Ni) | 5.09 | 3.63% | 7440-02-0 |
| | | Cobalt (Co) | 3.15 | 2.24% | 7440-48-4 |
| | | Iron (Fe) | 9.47 | 6.75% | 7439-89-6 |
| Base | Ceramic | Alumina (Al ₂ O ₃) | 79.178 | 56.4% | 1344-28-1 |
| | | Silicon Oxide (SiO ₂) | 3.143 | 2.24% | 14808-60-7 |
| | | Chromium Oxide (Cr ₂ O ₃) | 3.379 | 2.41% | 1308-38-9 |
| | | Titanium Oxide (TiO ₂) | 0.873 | 0.622% | 13463-67-7 |
| | | Magnesium Oxide (MgO) | 0.437 | 0.311% | 1309-48-4 |
| | | Calcium Oxide (CaO) | 0.297 | 0.212% | 1305-78-8 |
| | + Metallization | Tungsten (W) | 12.272 | 8.74% | 7440-33-7 |
| | | Molybdenum (Mo) | 0.380 | 0.27% | 7439-98-7 |
| | + Nickel Plating | Nickel (Ni) | 4.740 | 3.38% | 7440-02-0 |
| | | Cobalt (Co) | 0.395 | 0.28% | 7440-48-4 |
| | + Gold Plating | Gold (Au) | 0.624 | 0.445% | 7440-57-5 |
| | + Seal ring | Iron (Fe) | 5.809 | 4.14% | 7439-89-6 |
| | | Nickel (Ni) | 3.119 | 2.22% | 7440-02-0 |
| | | Cobalt (Co) | 1.829 | 1.30% | 7440-48-4 |
| | + silver solder | Silver (Ag) | 2.269 | 1.62% | 7440-22-4 |
| | | Copper (Cu) | 0.400 | 0.285% | 7440-50-8 |
| | I C | I C | Aluminum (Al) | 0.0021 | 0.00150% |
| Silicon (Si) | | | 0.950 | 0.68% | 7440-21-3 |
| Gold | | Gold (Au) | 0.480 | 0.342% | 7440-57-5 |
| Adhesive | | Silver (Ag) | 0.000210 | 0.000150% | 7440-22-4 |
| | | Epoxy | 0.0000700 | 0.0000499% | |
| Crystal | Crystal | Silicon Dioxide (SiO ₂) | 2.04 | 1.45% | 14808-60-7 |
| | Electrode | Silver (Ag) | 0.019 | 0.0135% | 7440-22-4 |
| | | Nickel (Ni) | 0.000159 | 0.000113% | 7440-02-0 |
| | Adhesive | Silver (Ag) | 0.00037 | 0.000264% | 7440-22-4 |
| | | Silicon (Si) | 0.000125 | 0.000089% | 7440-21-3 |
| TOTAL | | | 140.3 | 100.00% | |

3rd Party (SGS) Material Report**Test Report**

No. 2053204/EC

Date : Mar 01 2006

Page 1 of 2

FOX ELECTRONICS
5570 ENTERPRISE PARKWAY
FT. MYERS, FL 33905

Report on the submitted sample said to be CERAMIC SEAM SEAL OSCILLATOR.

SGS Job No. : 1981176
Supplier / Manufacturer : FOX ELECTRONICS
Sample Receiving Date : FEB 17 2006
Testing Period : FEB 18 - 24 2006

Test Requested :
1) To determine the Cadmium Content in the submitted sample.
2) To determine the Lead Content in the submitted sample.
3) To determine the Mercury Content in the submitted sample.
4) To determine the Hexavalent Chromium Content on the submitted sample.
5) To determine PBBs (polybrominated biphenyls) and PBDEs (Polybrominated diphenylethers) of the submitted sample.

Test Method :
1-3) With reference to EPA Method 3051/ 3052. Analysis was performed by Inductively Coupled Argon Plasma-Atomic Emission Spectrometry (ICP-AES).
4) With reference to EPA Method 3060A & 7196A. The sample was alkaline digested by using EPA Method 3060A, and then analyzed by using Colorimetric method 7196A (by UV-Vis Spectrophotometer).
5) With reference to EPA Method 3540C/ 3550C. Analysis was performed by GC/MS or LC/ MS.

Test Results : 1-5) Please refer to next page.

Signed for and on behalf of
SGS Hong Kong Ltd



 Ho Ka Tung, Family
Laboratory Executive

This Test Report is issued by the Company subject to its General Conditions of Service printed overleaf. Attention is drawn to the limitations of liability, indemnification and jurisdictional issues defined therein. The results shown in this test report refer only to the sample(s) tested unless otherwise stated. This Test Report cannot be reproduced, except in full, without prior written permission of the Company.

3rd Party (SGS) Material Report (continued)

Test Report

No. 2053204/EC

Date : Mar 01 2006

Page 2 of 2

Test Results :

| <u>Test Item</u> | <u>1</u> | <u>Detection Limit</u> |
|--|----------|------------------------|
| 1) Cadmium (Cd) | ND | 2 ppm |
| 2) Lead (Pb) | ND | 2 ppm |
| 3) Mercury (Hg) | ND | 2 ppm |
| 4) Hexavalent Chromium (Cr ⁶⁺) | ND | 2 ppm |

(Results shown are of the total weight of samples)

Note : ppm = mg/kg
 ND = Not Detected
 Not detected is reported when the reading is less than detection limit value

5)

| <u>Flame Retardants</u> | <u>1</u> | <u>Detection Limit</u> |
|--|----------|------------------------|
| Polybrominated Biphenyls (PBBs) | --- | --- |
| Monobromobiphenyl | ND | 5 ppm |
| Dibromobiphenyl | ND | 5 ppm |
| Tribromobiphenyl | ND | 5 ppm |
| Tetrabromobiphenyl | ND | 5 ppm |
| Pentabromobiphenyl | ND | 5 ppm |
| Hexabromobiphenyl | ND | 5 ppm |
| Heptabromobiphenyl | ND | 5 ppm |
| Octabromobiphenyl | ND | 5 ppm |
| Nonabromobiphenyl | ND | 5 ppm |
| Decabromobiphenyl | ND | 5 ppm |
| Polybrominated Diphenylethers (PBDEs) | --- | --- |
| Monobromodiphenyl ether | ND | 5 ppm |
| Dibromodiphenyl ether | ND | 5 ppm |
| Tribromodiphenyl ether | ND | 5 ppm |
| Tetrabromodiphenyl ether | ND | 5 ppm |
| Pentabromodiphenyl ether | ND | 5 ppm |
| Hexabromodiphenyl ether | ND | 5 ppm |
| Heptabromodiphenyl ether | ND | 5 ppm |
| Octabromodiphenyl ether | ND | 5 ppm |
| Nonabromodiphenyl ether | ND | 5 ppm |
| Decabromodiphenyl ether | ND | 5 ppm |

Note : ppm = mg/kg
 ND = Not Detected
 Not detected is reported when the reading is less than detection limit value.

Sample Description:

1. Black Ceramic w/ Silvery, Golden Metal w/ Silvery Chips

*** End of Report ***

This Test Report is issued by the Company subject to its General Conditions of Service printed overleaf. Attention is drawn to the limitations of liability, indemnification and jurisdictional issues defined therein. The results shown in this test report refer only to the sample(s) tested unless otherwise stated. This Test Report cannot be reproduced, except in full, without prior written permission of the Company.



Mechanical Testing

| Parameter | Test Method |
|--------------------------|--|
| Mechanical Shock | Drop from 75cm to hardwood surface – 3 times |
| Mechanical Vibration | 10~55Hz, 1.5mm amplitude, 1 Minute Sweep 2 Hours each in 3 Directions (X, Y, Z) |
| High Temperature Burn-in | Under Power @ 125°C for 2000 Hours (results below) |
| Hermetic Seal | He pressure: 4 ±1 kgf / cm ² 2 Hour soak |

2,000 Hour Burn-In

Burn-In Testing – under power 2000 Hours, 125°C

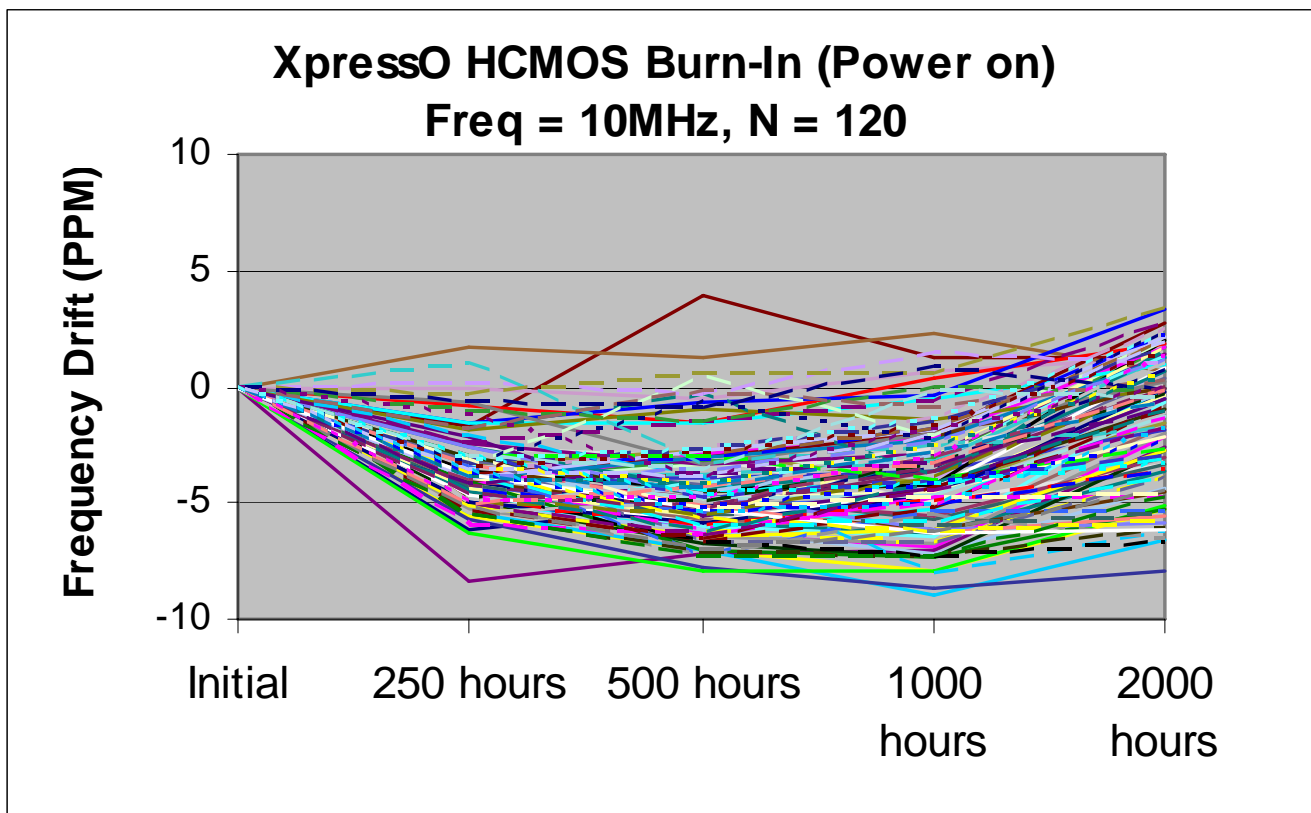

MTTF / FITS Calculations

Products are grouped together by process for MTTF calculations.
 (All XpressO output and package types are manufactured with the same process)

Number of Parts Tested: 360 (120 of each output type: HCMOS, LVDS, LVPECL)
Number of Failures: 0
Test Temperature: 125°C
Number of Hours: 2000

MTTF was calculated using the following formulas:

[1.] Device Hours (*devhrs*) = (number of devices) x (hours at elevated temperature in °K)

$$[2.] MTTF = \frac{devhrs \times af \times 2}{\chi^2}$$

$$[3.] FITS = \frac{1}{MTTF} * 10^9$$

Where:

| Label | Name | Formula/Value |
|----------------------|----------------------|---|
| <i>af</i> | Acceleration Factor | $e^{\left(\frac{eV}{k}\right) \times \left(\frac{1}{t_1} - \frac{1}{t_2}\right)}$ |
| <i>eV</i> | Activation Energy | 0.40 V |
| <i>k</i> | Boltzmann's Constant | 8.62 X 10 ⁻⁵ eV/°K |
| <i>t₁</i> | | Operating Temperature (°K) |
| <i>t₂</i> | | Accelerated Temperature (°K) |
| Θ | Theta | Confidence Level (60% industry standard) |
| <i>r</i> | Failures | Number of failed devices |
| χ^2 | Chi-Square | statistical significance for bivariate tabular analysis [table look-up] based on assumed Θ (Theta – confidence) and number of failures (<i>r</i>) For zero failures (60% Confidence): $\chi^2 = 1.830$ |

$$DEVICE-HOURS = 360 \times 2000 \text{ HOURS} = 720,000$$

$$ACCELERATION FACTOR = e^{\left(\frac{0.40}{8.625}\right) \times \left(\frac{1}{298} - \frac{1}{398}\right)} = 49.91009$$

$$MTTF = \frac{720,000 \times 49.91009 \times 2}{1.833} = 39,209,238 \text{ Hours}$$

$$\text{Failure Rate} = \frac{1.833}{720,000 \times 49.91009 \times 2} = 2.55E-8$$

$$FITS = \text{Failure Rate} * 1E9 = 26$$

Notes :
Other XPRESSO Links
[XPRESSO Brochure](#)
Crystal Oscillators
[HCMOS 5 x 3.2mm 3.3V XO 0.75 to 250MHz](#)
[HCMOS 7 x 5mm 3.3V XO 0.75 to 250MHz](#)
[LVPECL 5 x 3.2mm 3.3V XO 0.75 to 1.35GHz](#)
[LVPECL 7 x 5mm 3.3V XO 0.75 to 1.35GHz](#)
[LVDS 5 x 3.2mm 3.3V XO 0.75 to 1.35GHz](#)
[LVDS 7 x 5mm 3.3V XO 0.75 to 1.35GHz](#)
Voltage Controlled Crystal Oscillators
[HCMOS 5 x 3.2mm 3.3V VCXO 0.75 to 250MHz](#)
[HCMOS 7 x 5mm 3.3V VCXO 0.75 to 250MHz](#)
[LVPECL 5 x 3.2mm 3.3V VCXO 0.75 to 1.35GHz](#)
[LVPECL 7 x 5mm 3.3V VCXO 0.75 to 1.35GHz](#)
[LVDS 5 x 3.2mm 3.3V VCXO 0.75 to 1.35GHz](#)
[LVDS 7 x 5mm 3.3V VCXO 0.75 to 1.35GHz](#)
[Main Website www.foxonline.com](http://www.foxonline.com)
Patent Numbers:

US 6,664,860, US 5,960,403, US 5,952,890; US 5,960,405; US 6,188,290;

Foreign Patents: R.S.A. 98/0866, R.O.C. 120851; Singapore 67081, 67082; EP 0958652

China ZL 98802217.6, Malaysia MY-118540-A, Philippines 1-1998-000245, Hong Kong #HK1026079, Mexico #232179

US and Foreign Patents Pending

XpressO™ Fox Electronics

Contact Information
(USA)-Worldwide Headquarters

Tel: 888-GET-2-FOX

Outside US: +1.239.693.0099,

Fax: +1.239.693.1554

 Email: www.foxonline.com/email.htm
Fox Hong Kong

Tel: +852.2854.4285,

Fax: +852.2854.4282

 Email: www.foxonline.com/email.htm
Fox EMEA

Tel/Fax: +44.1767.312632

 Email: www.foxonline.com/email.htm
Fox Japan

Tel: +81.3.3374.2079,

Fax: +81.3.3377.5221

 Email: www.foxonline.com/email.htm
Fox Taiwan

Tel: +886-2-22073427,

Fax: +886-2-22073486

 Email: www.foxonline.com/email.htm

The above specifications, having been carefully prepared and checked, is believed to be accurate at the time of publication; however, no responsibility is assumed by Fox Electronics for inaccuracies.