

September 1995

### Features

- 3 Micron Radiation Hardened CMOS SOS
- Total Dose 200K RAD (Si)
- SEP Effective LET No Upsets: >100 MEV-cm<sup>2</sup>/mg
- Single Event Upset (SEU) Immunity < 2 x 10<sup>-9</sup> Errors/Bit-Day (Typ)
- Dose Rate Survivability: >1 x 10<sup>12</sup> RAD (Si)/s
- Dose Rate Upset >10<sup>10</sup> RAD (Si)/s 20ns Pulse
- Latch-Up Free Under Any Conditions
- Fanout (Over Temperature Range)
  - Standard Outputs - 10 LSTTL Loads
- Military Temperature Range: -55°C to +125°C
- Significant Power Reduction Compared to LSTTL ICs
- DC Operating Voltage Range: 4.5V to 5.5V
- LSTTL Input Compatibility
  - VIL = 0.8V Max
  - VIH = VCC/2 Min
- Input Current Levels I<sub>i</sub> ≤ 5μA @ VOL, VOH

### Description

The Intersil HCTS190MS is an asynchronously presettable BCD Decade synchronous counter. Presetting the counter to the number on the preset data inputs (P0 - P3) is accomplished by a low on the parallel load input ( $\overline{PL}$ ). Counting occurs when ( $\overline{PL}$ ) is high, Count Enable ( $\overline{CE}$ ) is low and the Up/Down ( $\overline{U/D}$ ) input is either low for up-counting or high for down-counting. The counter is incremented or decremented synchronously with the low-to-high transition of the clock.

When an overflow or underflow of the counter occurs, the Terminal Count output (TC), which is low during counting, goes high and remains high for one clock cycle. This output can be used for look-ahead carry in high speed cascading. The TC output also initiates the Ripple Clock output ( $\overline{RC}$ ) which, normally high, goes low and remains low for the low-level portion of the clock pulse. These counter can be cascaded using the Ripple Carry output.

If the decade counter is preset to an illegal state or assumes an illegal state when power is applied, it will return to the normal sequence in one or two counts

The HCTS190MS utilizes advanced CMOS/SOS technology to achieve high-speed operation. This device is a member of radiation hardened, high-speed, CMOS/SOS Logic Family.

The HCTS190MS is supplied in a 16 lead Ceramic flatpack (K suffix) or a SBDIP Package (D suffix).

### Ordering Information

PART NUMBER	TEMPERATURE RANGE	SCREENING LEVEL	PACKAGE
HCTS190DMSR	-55°C to +125°C	Intersil Class S Equivalent	16 Lead SBDIP
HCTS190KMSR	-55°C to +125°C	Intersil Class S Equivalent	16 Lead Ceramic Flatpack
HCTS190D/Sample	+25°C	Sample	16 Lead SBDIP
HCTS190K/Sample	+25°C	Sample	16 Lead Ceramic Flatpack
HCTS190HMSR	+25°C	Die	Die

### Pinouts

16 LEAD CERAMIC DUAL-IN-LINE METAL SEAL PACKAGE  
(SBDIP) MIL-STD-1835 CDIP2-T16, LEAD FINISH C

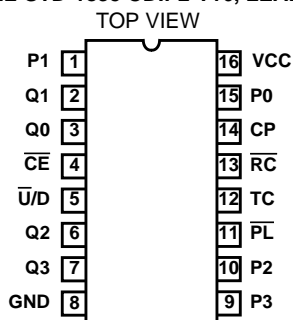

16 LEAD CERAMIC METAL SEAL FLATPACK PACKAGE  
(FLATPACK) MIL-STD-1835 CDFP4-F16, LEAD FINISH C

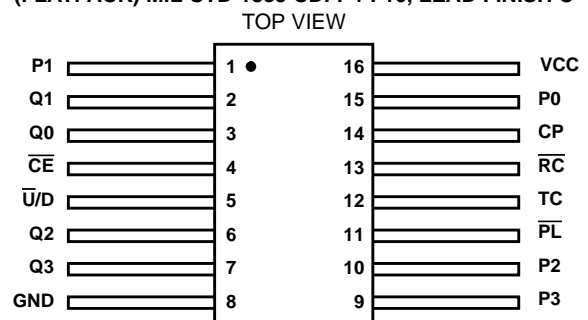

Functional Diagram

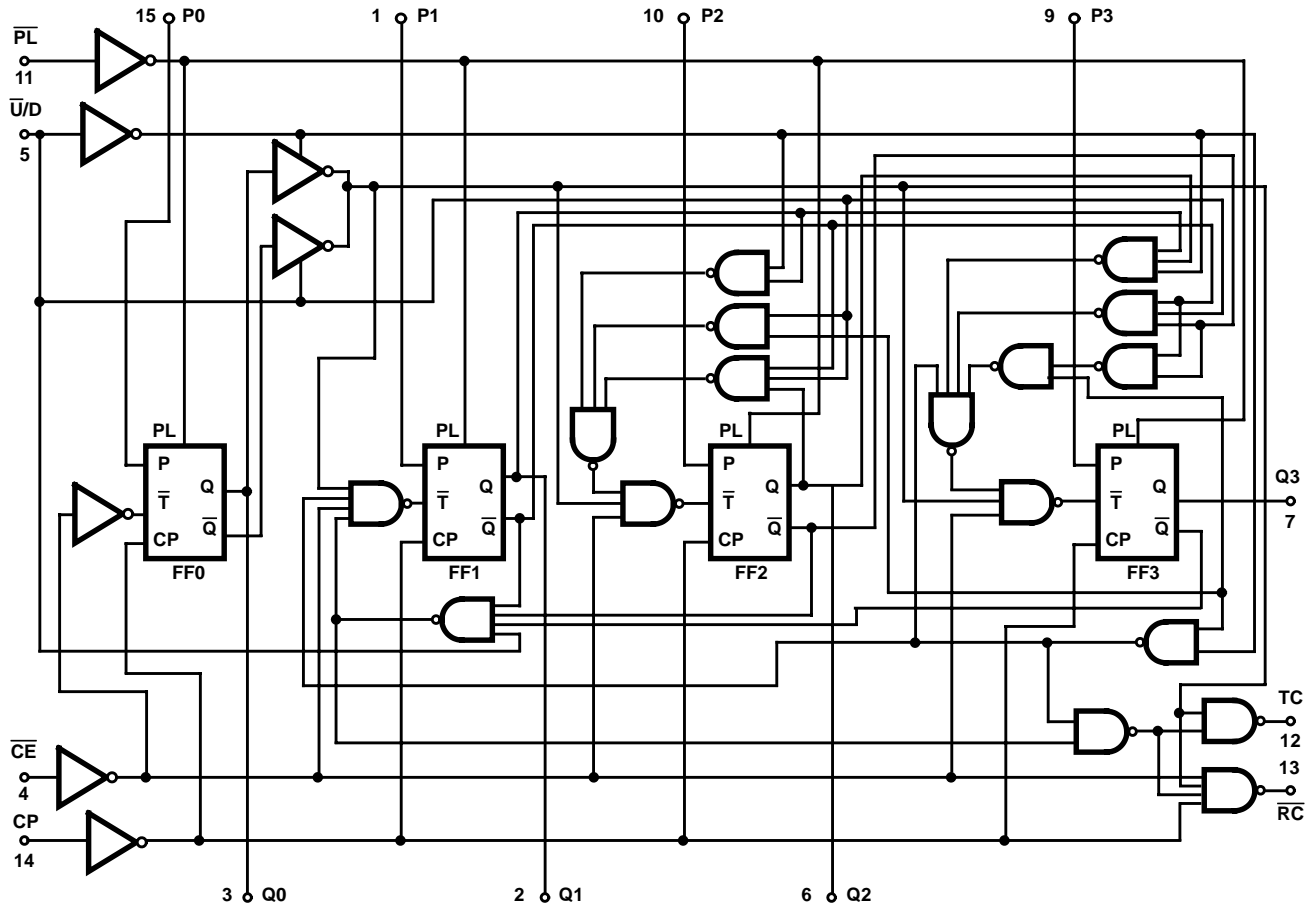

TRUTH TABLE

FUNCTION	$\overline{P}$	$\overline{CE}$	$\overline{U/D}$	CP
Count Up	H	L	L	
Count Down	H	L	H	
Asynchronous Preset	L	X	X	X
No Change	H	H	X	X

H = High Level

L = Low Level

X = Immaterial

= Transition from low to high

NOTE:  $\overline{U/D}$  or  $\overline{CE}$  should be changed only when clock is high.

# Specifications HCTS190MS

## Absolute Maximum Ratings

Supply Voltage (VCC) . . . . .	-0.5V to +7.0V
Input Voltage Range, All Inputs . . . . .	-0.5V to VCC +0.5V
DC Input Current, Any One Input . . . . .	±10mA
DC Drain Current, Any One Output . . . . .	±25mA
(All Voltage Reference to the VSS Terminal)	
Storage Temperature Range (TSTG) . . . . .	-65°C to +150°C
Lead Temperature (Soldering 10sec) . . . . .	+265°C
Junction Temperature (TJ) . . . . .	+175°C
ESD Classification . . . . .	Class 1

## Reliability Information

Thermal Resistance	$\theta_{JA}$	$\theta_{JC}$
SBDIP Package . . . . .	73°C/W	24°C/W
Ceramic Flatpack Package . . . . .	114°C/W	29°C/W
Maximum Package Power Dissipation at +125°C Ambient		
SBDIP Package . . . . .	0.68W	
Ceramic Flatpack Package . . . . .	0.44W	
If device power exceeds package dissipation capability, provide heat sinking or derate linearly at the following rate:		
SBDIP Package . . . . .	13.7mW/°C	
Ceramic Flatpack Package . . . . .	8.8mW/°C	

*CAUTION: As with all semiconductors, stress listed under "Absolute Maximum Ratings" may be applied to devices (one at a time) without resulting in permanent damage. This is a stress rating only. Exposure to absolute maximum rating conditions for extended periods may affect device reliability. The conditions listed under "Electrical Performance Characteristics" are the only conditions recommended for satisfactory device operation..*

## Operating Conditions

Supply Voltage(VCC) . . . . .	+4.5V to +5.5V	Input Low Voltage (VIL) . . . . .	0.0V to 0.8V
Input Rise and Fall Times @ 4.5 VCC (TR, TF) . . . . .	.500ns Max	Input High Voltage (VIH) . . . . .	VCC/2 to VCC
Operating Temperature Range (TA) . . . . .	-55°C to +125°C		

**TABLE 1. DC ELECTRICAL PERFORMANCE CHARACTERISTICS**

PARAMETER	SYMBOL	(NOTE 1) CONDITIONS	GROUP A SUB- GROUPS	TEMPERATURE	LIMITS		UNITS
					MIN	MAX	
Quiescent Current	ICC	VCC = 5.5V, VIN = VCC or GND	1	+25°C	-	40	µA
			2, 3	+125°C, -55°C	-	750	µA
Output Current (Sink)	IOL	VCC = 4.5V, VIH = 4.5V, VOUT = 0.4V, VIL = 0V	1	+25°C	4.8	-	mA
			2, 3	+125°C, -55°C	4.0	-	mA
Output Current (Source)	IOH	VCC = 4.5V, VIH = 4.5V, VOUT = VCC -0.4V, VIL = 0V	1	+25°C	-4.8	-	mA
			2, 3	+125°C, -55°C	-4.0	-	mA
Output Voltage Low	VOL	VCC = 4.5V, VIH = 2.25V, IOL = 50µA, VIL = 0.8V	1, 2, 3	+25°C, +125°C, -55°C	-	0.1	V
		VCC = 5.5V, VIH = 2.75V, IOL = 50µA, VIL = 0.8V	1, 2, 3	+25°C, +125°C, -55°C	-	0.1	V
Output Voltage High	VOH	VCC = 4.5V, VIH = 2.25V, IOL = -50µA, VIL = 0.8V	1, 2, 3	+25°C, +125°C, -55°C	VCC -0.1	-	V
		VCC = 5.5V, VIH = 2.75V, IOL = -50µA, VIL = 0.8V	1, 2, 3	+25°C, +125°C, -55°C	VCC -0.1	-	V
Input Leakage Current	IIN	VCC = 5.5V, VIN = VCC or GND	1	+25°C	-	±0.5	µA
			2, 3	+125°C, -55°C	-	±5.0	µA
Noise Immunity Functional Test	FN	VCC = 4.5V, VIH = 2.25V, VIL = 0.8V (Note 2)	7, 8A, 8B	+25°C, +125°C, -55°C	-	-	-

**NOTES:**

1. All voltages reference to device GND.
2. For functional tests VO ≥ 4.0V is recognized as a logic "1", and VO ≤ 0.5V is recognized as a logic "0".

## Specifications HCTS190MS

**TABLE 2. AC ELECTRICAL PERFORMANCE CHARACTERISTICS**

PARAMETER	SYMBOL	(NOTES 1, 2) CONDITIONS	GROUP A SUB- GROUPS	TEMPERATURE	LIMITS		UNITS
					MIN	MAX	
$\overline{PL}$ to Qn	TPLH	VCC = 4.5V	9	+25°C	2	32	ns
			10, 11	+125°C, -55°C	2	37	ns
	TPHL	VCC = 4.5V	9	+25°C	2	38	ns
			10, 11	+125°C, -55°C	2	44	ns
Pn to Qn	TPLH	VCC = 4.5V	9	+25°C	2	24	ns
			10, 11	+125°C, -55°C	2	28	ns
	TPHL	VCC = 4.5V	9	+25°C	2	36	ns
			10, 11	+125°C, -55°C	2	41	ns
CP to Qn	TPLH	VCC = 4.5V	9	+25°C	2	24	ns
			10, 11	+125°C, -55°C	2	29	ns
	TPHL	VCC = 4.5V	9	+25°C	2	23	ns
			10, 11	+125°C, -55°C	2	27	ns
CP to $\overline{RC}$	TPLH	VCC = 4.5V	9	+25°C	2	17	ns
			10, 11	+125°C, -55°C	2	19	ns
	TPHL	VCC = 4.5V	9	+25°C	2	26	ns
			10, 11	+125°C, -55°C	2	29	ns
CP to TC	TPLH	VCC = 4.5V	9	+25°C	2	33	ns
			10, 11	+125°C, -55°C	2	39	ns
	TPHL	VCC = 4.5V	9	+25°C	2	33	ns
			10, 11	+125°C, -55°C	2	39	ns
$\overline{U/D}$ to $\overline{RC}$	TPLH	VCC = 4.5V	9	+25°C	2	32	ns
			10, 11	+125°C, -55°C	2	36	ns
	TPHL	VCC = 4.5V	9	+25°C	2	34	ns
			10, 11	+125°C, -55°C	2	38	ns
$\overline{U/D}$ to TC	TPLH	VCC = 4.5V	9	+25°C	2	29	ns
			10, 11	+125°C, -55°C	2	33	ns
	TPHL	VCC = 4.5V	9	+25°C	2	35	ns
			10, 11	+125°C, -55°C	2	38	ns
$\overline{CE}$ to $\overline{RC}$	TPLH	VCC = 4.5V	9	+25°C	2	20	ns
			10, 11	+125°C, -55°C	2	21	ns
	TPHL	VCC = 4.5V	9	+25°C	2	29	ns
			10, 11	+125°C, -55°C	2	31	ns

**NOTES:**

1. All voltages referenced to device GND.
2. AC measurements assume  $R_L = 500\Omega$ ,  $C_L = 50pF$ , Input  $T_R = T_F = 3ns$ ,  $V_{IL} = GND$ ,  $V_{IH} = 3V$ .

# Specifications HCTS190MS

**TABLE 3. ELECTRICAL PERFORMANCE CHARACTERISTICS**

PARAMETER	SYMBOL	(NOTE 1) CONDITIONS	TEMPERATURE	LIMITS		UNITS
				MIN	MAX	
Capacitance Power Dissipation	CPD	VCC = 5.0V, f = 1MHz	+25°C	-	60	pF
			+125°C, -55°C	-	128	pF
Input Capacitance	CIN	VCC = 5.0V, f = 1MHz	+25°C	-	10	pF
			+125°C, -55°C	-	10	pF
Output Transition Time	TTHL TTLH	VCC = 4.5V	+25°C	-	15	ns
			+125°C, -55°C	-	22	ns
Maximum Operating Frequency (CPU, CPD)	FMAX	VCC = 4.5V	+25°C		30	MHz
			+125°C, -55°C		20	MHz
Setup Time Pn to $\overline{PL}$	TSU	VCC = 4.5V	+25°C	12	-	ns
			+125°C, -55°C	18	-	ns
Setup Time $\overline{CE}$ to CP	TSU	VCC = 4.5V	+25°C	12	-	ns
			+125°C, -55°C	18	-	ns
Setup Time $\overline{U/D}$ to CP	TSU	VCC = 4.5V	+25°C	18	-	ns
			+125°C, -55°C	27	-	ns
Hold Time Pn to $\overline{PL}$	TH	VCC = 4.5V	+25°C	2	-	ns
			+125°C, -55°C	2	-	ns
Hold Time $\overline{CE}$ to CP	TH	VCC = 4.5V	+25°C	2	-	ns
			+125°C, -55°C	2	-	ns
Hold Time $\overline{U/D}$ to CP	TH	VCC = 4.5V	+25°C	0	-	ns
			+125°C, -55°C	0	-	ns
Recovery Time	TREC	VCC = 4.5V	+25°C	12	-	ns
			+125°C, -55°C	18	-	ns
CP Pulse Width	TW	VCC = 4.5V	+25°C	16	-	ns
			+125°C, -55°C	24	-	ns
PLN Pulse Width	TW	VCC = 4.5V	+25°C	20		ns
			+125°C, -55°C	30		ns

NOTE:

- The parameters listed in Table 3 are controlled via design or process parameters. Min and Max Limits are guaranteed but not directly tested. These parameters are characterized upon initial design release and upon design changes which affect these characteristics.

**TABLE 4. DC POST RADIATION ELECTRICAL PERFORMANCE CHARACTERISTICS**

PARAMETER	SYMBOL	(NOTES 1, 2) CONDITIONS	TEMPERATURE	200K RAD LIMITS		UNITS
				MIN	MAX	
Quiescent Current	ICC	VCC = 5.5V, VIN = VCC or GND	+25°C	-	0.75	mA
Output Current (Sink)	IOL	VCC = 4.5V, VIN = VCC or GND, VOUT = 0.4V	+25°C	4.0	-	mA
Output Current (Source)	IOH	VCC = 4.5V, VIN = VCC or GND, VOUT = VCC -0.4V	+25°C	-4.0	-	mA

## Specifications HCTS190MS

**TABLE 4. DC POST RADIATION ELECTRICAL PERFORMANCE CHARACTERISTICS (Continued)**

PARAMETER	SYMBOL	(NOTES 1, 2) CONDITIONS	TEMPERATURE	200K RAD LIMITS		UNITS
				MIN	MAX	
Output Voltage Low	VOL	VCC = 4.5V and 5.5V, VIH = VCC/2, VIL = 0.8V, IOL = 50μA	+25°C	-	0.1	V
Output Voltage High	VOH	VCC = 4.5V and 5.5V, VIH = VCC/2, VIL = 0.8V, IOH = -50μA	+25°C	VCC -0.1	-	V
Input Leakage Current	IIN	VCC = 5.5V, VIN = VCC or GND	+25°C	-	±5	μA
Noise Immunity Functional Test	FN	VCC = 4.5V, VIH = 2.25V, VIL = 0.8V, (Note 3)	+25°C	-	-	-
$\overline{PL}$ to Qn	TPLH	VCC = 4.5V	+25°C	2	37	ns
	TPHL	VCC = 4.5V	+25°C	2	44	ns
Pn to Qn	TPLH	VCC = 4.5V	+25°C	2	24	ns
	TPHL	VCC = 4.5V	+25°C	2	41	ns
CP to Qn	TPLH	VCC = 4.5V	+25°C	2	29	ns
	TPHL	VCC = 4.5V	+25°C	2	27	ns
Cp to $\overline{RC}$	TPLH	VCC = 4.5V	+25°C	2	19	ns
	TPHL	VCC = 4.5V	+25°C	2	29	ns
CP to TC	TPLH	VCC = 4.5V	+25°C	2	39	ns
	TPHL	VCC = 4.5V	+25°C	2	39	ns
$\overline{U/D}$ to $\overline{RC}$	TPLH	VCC = 4.5V	+25°C	2	36	ns
	TPHL	VCC = 4.5V	+25°C	2	38	ns
$\overline{U/D}$ to TC	TPLH	VCC = 4.5V	+25°C	2	33	ns
	TPHL	VCC = 4.5V	+25°C	2	38	ns
$\overline{CE}$ to $\overline{RC}$	TPLH	VCC = 4.5V	+25°C	2	21	ns
	TPHL	VCC = 4.5V	+25°C	2	31	ns

**NOTES:**

1. All voltages referenced to device GND.
2. AC measurements assume RL = 500Ω, CL = 50pF, Input TR = TF = 3ns, VIL = GND, VIH = 3V.
3. For functional tests VO ≥ 4.0V is recognized as a logic "1", and VO ≤ 0.5V is recognized as a logic "0".

**TABLE 5. BURN-IN AND OPERATING LIFE TEST, DELTA PARAMETERS (+25°C)**

PARAMETER	GROUP B SUBGROUP	DELTA LIMIT
ICC	5	12μA
IOL/IOH	5	-15% of 0 Hour

# Specifications HCTS190MS

**TABLE 6. APPLICABLE SUBGROUPS**

CONFORMANCE GROUPS		METHOD	GROUP A SUBGROUPS	READ AND RECORD
Initial Test (Preburn-In)		100%/5004	1, 7, 9	ICC, IOL/H
Interim Test I (Postburn-In)		100%/5004	1, 7, 9	ICC, IOL/H
Interim Test II (Postburn-In)		100%/5004	1, 7, 9	ICC, IOL/H
PDA		100%/5004	1, 7, 9, Deltas	
Interim Test III (Postburn-In)		100%/5004	1, 7, 9	ICC, IOL/H
PDA		100%/5004	1, 7, 9, Deltas	
Final Test		100%/5004	2, 3, 8A, 8B, 10, 11	
Group A (Note 1)		Sample/5005	1, 2, 3, 7, 8A, 8B, 9, 10, 11	
Group B	Subgroup B-5	Sample/5005	1, 2, 3, 7, 8A, 8B, 9, 10, 11, Deltas	Subgroups 1, 2, 3, 9, 10, 11, (Note 2)
	Subgroup B-6	Sample/5005	1, 7, 9	
Group D		Sample/5005	1, 7, 9	

**NOTES:**

1. Alternate group A testing in accordance with method 5005 of MIL-STD-883 may be exercised.
2. Table 5 parameters only.

**TABLE 7. TOTAL DOSE IRRADIATION**

CONFORMANCE GROUPS	METHOD	TEST		READ AND RECORD	
		PRE RAD	POST RAD	PRE RAD	POST RAD
Group E Subgroup 2	5005	1, 7, 9	Table 4	1, 9	Table 4 (Note 1)

**NOTE:**

1. Except FN test which will be performed 100% Go/No-Go

**TABLE 8. STATIC AND DYNAMIC BURN-IN TEST CONNECTIONS**

OPEN	GROUND	1/2 VCC = 3V ± 0.5V	VCC = 6V ± 0.5V	OSCILLATOR	
				50kHz	25kHz
STATIC BURN-IN I TEST CONNECTIONS (Note 1)					
2, 3, 6, 7, 12, 13	1, 4, 5, 8 - 11, 14, 15	-	16	-	-
STATIC BURN-IN II TEST CONNECTIONS (Note 1)					
2, 3, 6, 7, 12, 13	8	-	1, 4, 5, 9 - 11, 14 - 16	-	-
DYNAMIC BURN-IN TEST CONNECTIONS (Note 2)					
-	1, 4, 5, 8 - 10, 15	2, 3, 6, 7, 12, 13	11, 16	14	-

**NOTES:**

1. Each pin except VCC and GND will have a resistor of 10KΩ ± 5% for static burn-in
2. Each pin except VCC and GND will have a resistor of 1KΩ ± 5% for dynamic burn-in

**TABLE 9. IRRADIATION TEST CONNECTIONS**

OPEN	GROUND	VCC = 5V ± 0.5V
2, 3, 6, 7, 12, 13	8	1, 4, 5, 9 - 11, 14 - 16

NOTE: Each pin except VCC and GND will have a resistor of 47KΩ ± 5% for irradiation testing.  
Group E, Subgroup 2, sample size is 4 dice/wafer 0 failures.

## HCTS190MS

### **Intersil Space Level Product Flow - 'MS'**

Wafer Lot Acceptance (All Lots) Method 5007 (Includes SEM)	100% Interim Electrical Test 1 (T1)
GAMMA Radiation Verification (Each Wafer) Method 1019, 4 Samples/Wafer, 0 Rejects	100% Delta Calculation (T0-T1)
100% Nondestructive Bond Pull, Method 2023	100% Static Burn-In 2, Condition A or B, 24 hrs. min., +125°C min., Method 1015
Sample - Wire Bond Pull Monitor, Method 2011	100% Interim Electrical Test 2 (T2)
Sample - Die Shear Monitor, Method 2019 or 2027	100% Delta Calculation (T0-T2)
100% Internal Visual Inspection, Method 2010, Condition A	100% PDA 1, Method 5004 (Notes 1 and 2)
100% Temperature Cycle, Method 1010, Condition C, 10 Cycles	100% Dynamic Burn-In, Condition D, 240 hrs., +125°C or Equivalent, Method 1015
100% Constant Acceleration, Method 2001, Condition per Method 5004	100% Interim Electrical Test 3 (T3)
100% PIND, Method 2020, Condition A	100% Delta Calculation (T0-T3)
100% External Visual	100% PDA 2, Method 5004 (Note 2)
100% Serialization	100% Final Electrical Test
100% Initial Electrical Test (T0)	100% Fine/Gross Leak, Method 1014
100% Static Burn-In 1, Condition A or B, 24 hrs. min., +125°C min., Method 1015	100% Radiographic, Method 2012 (Note 3)
	100% External Visual, Method 2009
	Sample - Group A, Method 5005 (Note 4)
	100% Data Package Generation (Note 5)

#### NOTES:

1. Failures from Interim electrical test 1 and 2 are combined for determining PDA 1.
2. Failures from subgroup 1, 7, 9 and deltas are used for calculating PDA. The maximum allowable PDA = 5% with no more than 3% of the failures from subgroup 7.
3. Radiographic (X-Ray) inspection may be performed at any point after serialization as allowed by Method 5004.
4. Alternate Group A testing may be performed as allowed by MIL-STD-883, Method 5005.
5. Data Package Contents:
  - Cover Sheet (Intersil Name and/or Logo, P.O. Number, Customer Part Number, Lot Date Code, Intersil Part Number, Lot Number, Quantity).
  - Wafer Lot Acceptance Report (Method 5007). Includes reproductions of SEM photos with percent of step coverage.
  - GAMMA Radiation Report. Contains Cover page, disposition, Rad Dose, Lot Number, Test Package used, Specification Numbers, Test equipment, etc. Radiation Read and Record data on file at Intersil.
  - X-Ray report and film. Includes penetrometer measurements.
  - Screening, Electrical, and Group A attributes (Screening attributes begin after package seal).
  - Lot Serial Number Sheet (Good units serial number and lot number).
  - Variables Data (All Delta operations). Data is identified by serial number. Data header includes lot number and date of test.
  - The Certificate of Conformance is a part of the shipping invoice and is not part of the Data Book. The Certificate of Conformance is signed by an authorized Quality Representative.



# HCTS190MS

## AC Timing Diagrams

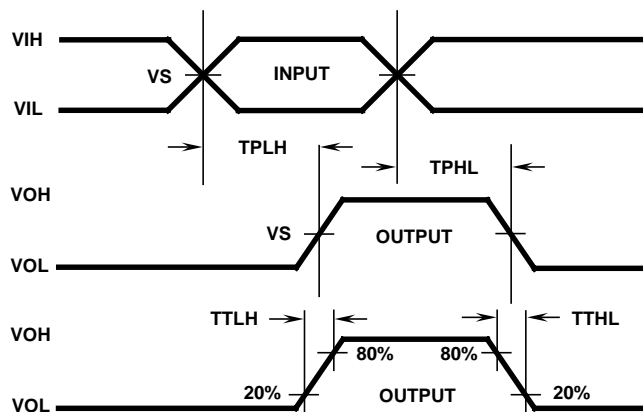

## AC Load Circuit

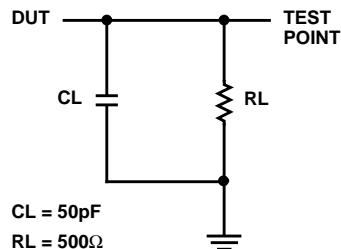

## AC VOLTAGE LEVELS

PARAMETER	HCTS	UNITS
VCC	4.50	V
$V_{IH}$	3.00	V
$V_S$	1.30	V
$V_{IL}$	0	V
GND	0	V

All Intersil semiconductor products are manufactured, assembled and tested under **ISO9000** quality systems certification.

*Intersil products are sold by description only. Intersil Corporation reserves the right to make changes in circuit design and/or specifications at any time without notice. Accordingly, the reader is cautioned to verify that data sheets are current before placing orders. Information furnished by Intersil is believed to be accurate and reliable. However, no responsibility is assumed by Intersil or its subsidiaries for its use; nor for any infringements of patents or other rights of third parties which may result from its use. No license is granted by implication or otherwise under any patent or patent rights of Intersil or its subsidiaries.*

For information regarding Intersil Corporation and its products, see web site <http://www.intersil.com>

## Sales Office Headquarters

### NORTH AMERICA

Intersil Corporation  
P. O. Box 883, Mail Stop 53-204  
Melbourne, FL 32902  
TEL: (321) 724-7000  
FAX: (321) 724-7240

### EUROPE

Intersil SA  
Mercure Center  
100, Rue de la Fusee  
1130 Brussels, Belgium  
TEL: (32) 2.724.2111  
FAX: (32) 2.724.22.05

### ASIA

Intersil (Taiwan) Ltd.  
Taiwan Limited  
7F-6, No. 101 Fu Hsing North Road  
Taipei, Taiwan  
Republic of China  
TEL: (886) 2 2716 9310  
FAX: (886) 2 2715 3029

# HCTS190MS

## Die Characteristics

### DIE DIMENSIONS:

104 x 86 mils

### METALLIZATION:

Type: AlSi

Metal Thickness:  $11\text{k}\text{\AA} \pm 1\text{k}\text{\AA}$

### GLASSIVATION:

Type:  $\text{SiO}_2$

Thickness:  $13\text{k}\text{\AA} \pm 2.6\text{k}\text{\AA}$

### WORST CASE CURRENT DENSITY:

$< 2.0 \times 10^5 \text{A/cm}^2$

### BOND PAD SIZE:

$100\mu\text{m} \times 100\mu\text{m}$

4 mils x 4 mils

## Metallization Mask Layout

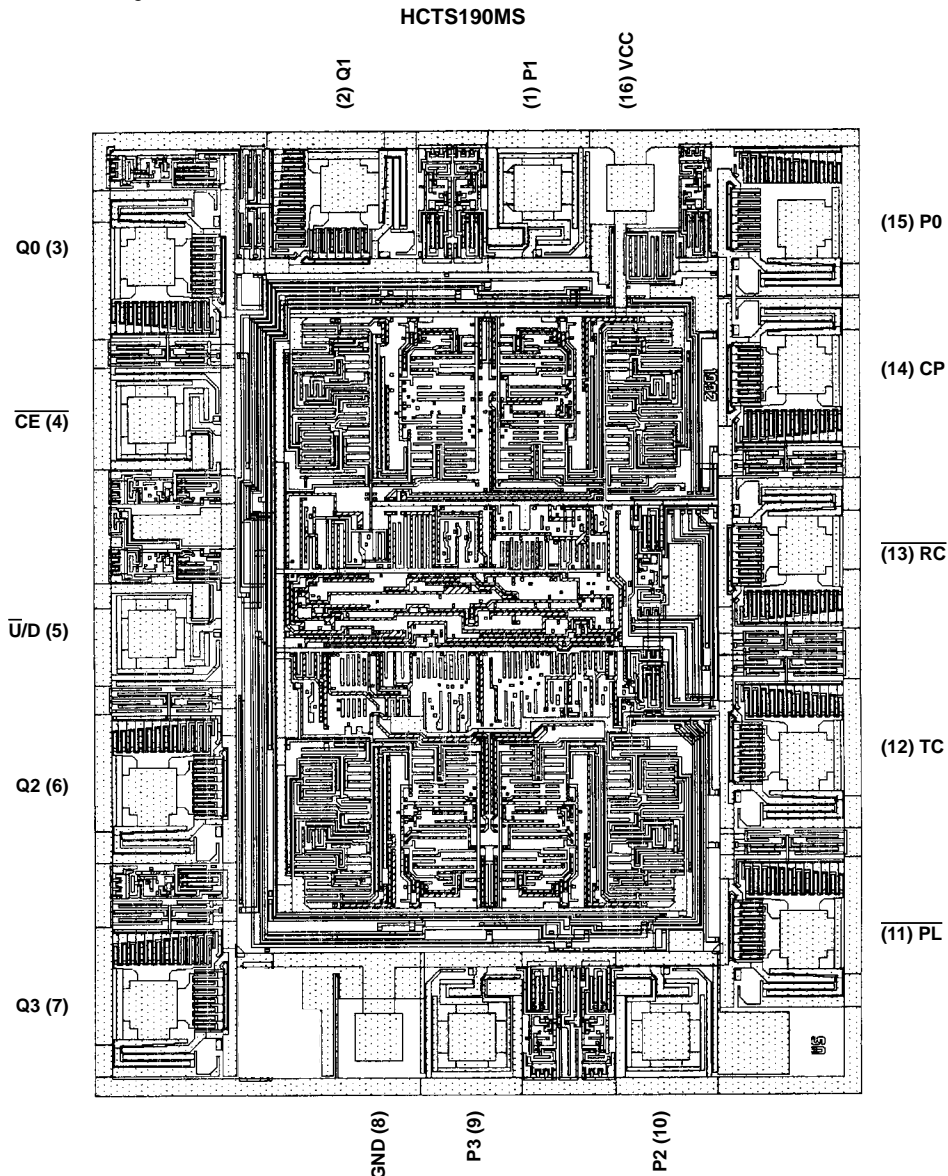

NOTE: The die diagram is a generic plot form a similar HCS device. It is intended to indicate approximate die size and bond pad location.  
The mask series for the HCTS190 is TA14444A.

Spec Number **518614**