

TSC693E
Memory Controller

User's Manual

For Embedded Real time 32-bit Computer
(ERC32)
for SPACE Applications

TABLE OF CONTENTS**Page**

1.	INTRODUCTION	4
1.1.	Scope	4
1.2.	Documents	5
1.2.1.	Applicable Documents	5
1.2.2.	Reference Documents	5
1.3.	Glossary	6
1.4.	Definitions	7
1.4.1.	Bit Numbering	7
1.4.2.	Signal Names	7
1.4.3.	Registers	7
2.	GENERAL OVERVIEW OF ERC32	8
2.1.	ERC32 Overview	8
3.	MEMORY CONTROLLER FUNCTIONS	10
3.1.	Data Types	12
3.2.	Memory Interface	12
3.2.1.	Memory Control Signals	12
3.2.2.	RAM	12
3.2.2.1.	Extended RAM	13
3.2.3.	Boot PROM	14
3.2.3.1.	Extended PROM	14
3.2.4.	Exchange Memory	15
3.2.5.	I/O	15
3.2.5.1.	Extended I/O	17
3.2.6.	MEC Memory Map	18
3.3.	DMA Interface	19
3.4.	Bus Arbiter	20
3.5.	Execution Modes	20
3.5.1.	Reset Mode	22
3.5.2.	Run Mode	22
3.5.3.	System Halt Mode	22
3.5.4.	Power-Down Mode	23
3.5.5.	Error Halt Mode	23
3.6.	Wait-State and Timeout Generator	23
3.7.	Memory Access Protection	24
3.7.1.	Unimplemented Areas	24
3.7.2.	RAM Write Access Protection	25
3.7.3.	Boot PROM Write Protection	26
3.8.	Register Access Protection	26
3.9.	EDAC	27
3.9.1.	Check Bit Generator	28
3.9.2.	Syndrome Generator	29
3.9.3.	Syndrome Detector	30

3.9.4.	Fault Injection	31
3.9.5.	Memory and I/O Parity	31
3.10.	Memory Redundancy	32
3.11.	Synchronous Traps	32
3.12.	Interrupts (Asynchronous Traps).....	33
3.13.	General Purpose and Real Time Clock Timers	36
3.14.	Watch Dog.....	38
3.15.	UART	40
3.16.	Parity Checking	41
3.17.	Error Handler.....	42
3.18.	System Availability	47
3.19.	Test mode and Test Access Port.....	47
3.19.1.	EDAC Test.....	47
3.19.2.	Parity Test	47
3.19.3.	Interrupt Test.....	47
3.19.4.	Error Test	48
3.19.5.	Test Access Port (TAP)	48
3.20.	System Clock.....	48
3.21.	MEC Registers	49
3.21.1.	Register Address Map.....	49
3.21.2.	Register Configuration and Bit Allocation	50
4.	MEMORY CONTROLLER SIGNAL DESCRIPTIONS	63
4.1.	Memory Controller Signal Summary	63
4.2.	MEC Detailed Signal Descriptions	65
4.2.1.	IU/FPU Interface Signals	65
4.2.2.	Memory System Interface Signals	71
4.2.3.	Interrupt and Control Signals.....	75
4.2.4.	Test Access Port Signals.....	77
4.2.5.	UART Interface.....	78
4.2.6.	Power and Clock Signals	79
5.	ELECTRICAL AND MECHANICAL SPECIFICATION.....	80
5.1.	Maximum Rating and DC Characteristics	80
5.1.1.	Maximum Ratings.....	80
5.1.2.	Operating Range	80
5.1.3.	DC Characteristics over the Operating Range	80
5.1.4.	Capacitance Ratings	81
5.2.	Package Description	81
5.2.1.	Pin Assignments.....	81
5.2.2.	Package Diagram	82

APPENDIX 1 - TIMING DIAGRAMS

1. INTRODUCTION

1.1. Scope

This document constitutes a functional specification of iteration two of the TSC693E Memory Controller (MEC) which is an element in the ERC32 microprocessor core. It is intended to function as a User's guide both for the software and hardware developers.

The document is divided into the following sections:

- **GENERAL OVERVIEW OF ERC32**
A short overview of a typical ERC32 based system.
- **TSC693E MEMORY CONTROLLER FUNCTIONS**
Detailed description of the MEC functions including software interface.
- **TSC693E MEMORY CONTROLLER SIGNAL DESCRIPTIONS**
Functional description of MEC signals.
- **TSC693E ELECTRICAL AND MECHANICAL SPECIFICATION**
- **TIMING DIAGRAMS (APPENDIX 1)**
Timing specifications and diagrams.

1.2. Documents

1.2.1. Applicable Documents

- AD1 ESA 32-Bit Microprocessor and Computer Development Programme
Statement of Work, WDI/JG/1317/NL, Issue 2.1, 28-05-1991.
- AD2 Specification for a 32-bit embedded computing core (ERC32),
WDI/JG/1334/NL, Issue 3, 29-05-1991.
- AD3 32-bit Microprocessor Software Tools Technical Requirements,
WDI/1339/FGM/NL, 05-06-1991.
- AD4 ERC32 Technical Specification, MCD/SPC/0001/SE, issue 7, 1 Apr 1994.

1.2.2. Reference Documents

- RD1 SPARC Standard Version 7
- RD2 TSC691E Integer Unit
- RD3 TSC692E Floating Point Unit User's Manual

1.3. Glossary

AD	Applicable Document
ASI	Address Space Identifier
ATAC	Ada TAsking Coprocessor
CS	Chip Select
DMA	Direct Memory Access
EDAC	Error Detection And Correction
EEPROM	Electrically Erasable Programmable Read Only Memory
ERC32	32 bit Embedded Real-time Computing Core
EXM	EXchange Memory
FAR	Failing Address Register
FPU	Floating Point Unit
I/O	Input/Output
ICR	Interrupt Clear Register
IFR	Interrupt Force Register
IMR	Interrupt Mask Register
IPR	Interrupt Pending Register
IU	Integer Unit
MEC	MEmory Controller
PROM	Programmable Read Only Memory
RAM	Random Access Memory
RD	Reference Document
ROM	Read Only Memory
RTC	Real Time Clock
SFSR	System Fault Status Register
SW	Software
TAP	Test Access Port
TBC	To Be Confirmed
TBD	To Be Defined
UART	Universal Asynchronous Receiver Transmitter
WD	Watch Dog

1.4. Definitions

1.4.1. Bit Numbering

In this document the following conventions are used:

- The most significant bit in a vector has the highest bit number and the leftmost position in a field.
- The least significant bit in a vector has the lowest bit number and the rightmost position in a field.

1.4.2. Signal Names

The following conventions are used for signal names:

- Signal names are written in capital letters, SIGNALNAME.
- Active low signals are named, SIGNALNAME*.

1.4.3. Registers

The following convention is used for registers.

- Register names are bolded, **Register Name**.

2. GENERAL OVERVIEW OF ERC32

2.1. ERC32 Overview

The objective of the ERC32 is to provide a high performance 32-bit computing core for on-board embedded real-time computers. The core is characterized by low circuit complexity and power consumption. Extensive concurrent error detection and support for fault-tolerance and reconfiguration is emphasized.

In addition to the main objective, the ERC32 core is possible to use for performance demanding research applications in deep space probes. In addition to the above characteristics the radiation tolerance and error masking are important. By including support for reconfigurable of the error handling the different demands from the applications can be optimized for the best purpose in each case.

The ERC32 is to be used as a building block only requiring memory and application specific peripherals to be added to form a complete on-board computer. All other system support functions are provided by the core.

The ERC32 incorporates the followings functions:

- Processor, which consists of one Integer Unit: TSC691E (called IU in this document) and one Floating Point Unit: TSC692E (called FPU in this document). The processor includes concurrent error detection facilities.
- Memory Controller: TSC693E (called MEC in this document), which is a unit consisting of all necessary support functions such as memory control and protection, EDAC, wait state generator, timers, interrupt handler, watch dog, UARTs, and test support. The unit also includes concurrent error detection facilities.
- One or two oscillator(s).
- Buffers necessary to interface with memory and peripherals.

Figure 1 schematically shows a basic ERC32 computer with external functions added to form a complete system.

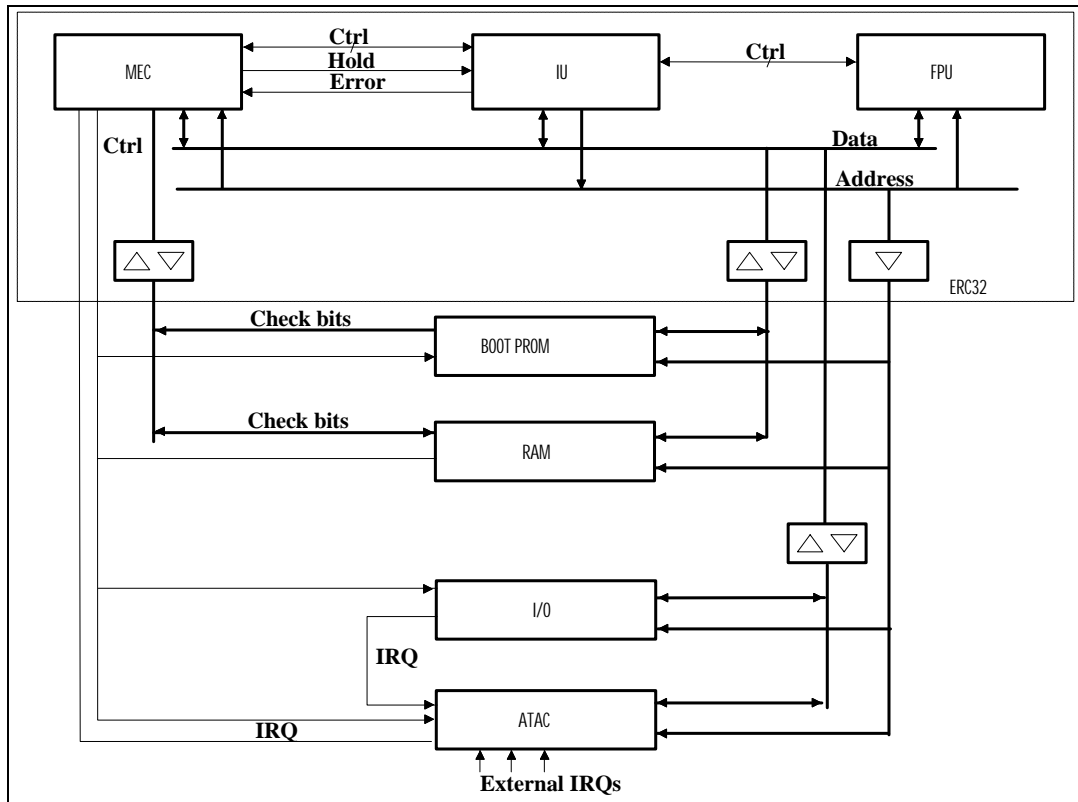

Figure 1 - ERC32 Computer with typical peripherals

3. MEMORY CONTROLLER FUNCTIONS

All support functions of the ERC32 except for the local clock/oscillator and address and data bus drivers (buffers and latches) are incorporated in one single chip memory controller unit (MEC).

The MEC is designed to interface the IU and the FPU to external memory and I/O units thus forming a system, with which computers for on-board embedded real-time applications can be built. In order to achieve this the MEC constitutes all necessary support and on-chip resources accordingly:

- System start up control and reset
- Power down mode control
- System clock
- Watchdog function
- Memory interface to RAM ranging from 256 Kbyte to 32 Mbyte
- Memory interface to PROM ranging from 128 Kbyte to 4 Mbyte
- I/O interface to exchange memory (e.g. DPRAM) ranging from 4 Kbyte to 512 Kbyte.
- I/O interface to four peripherals
- DMA interface
- Bus arbiter
- Programmable wait-state generator
- Programmable memory access protection
- Memory redundancy control
- EDAC, with byte and halfword write support
- Trap handler including 15-level interrupt controller
- One 32-bit general purpose timer with 16-bit scaler
- One 32-bit timer with 8-bit scaler (Real-Time-Clock)
- UART function with two serial channels
- Built-in concurrent error detection including support for master/slave checking of IU and FPU
- System error handler
- Parity control on system bus
- Test support including a minimal TAP interface

The MEC interfaces directly to the address, data, and control buses of the IU and FPU, requiring no additional components. It also interfaces directly to external memory and I/O units only requiring additional buffers for the address and data bus.

The architecture of the MEC is illustrated in Figure 2.

MEC Architecture

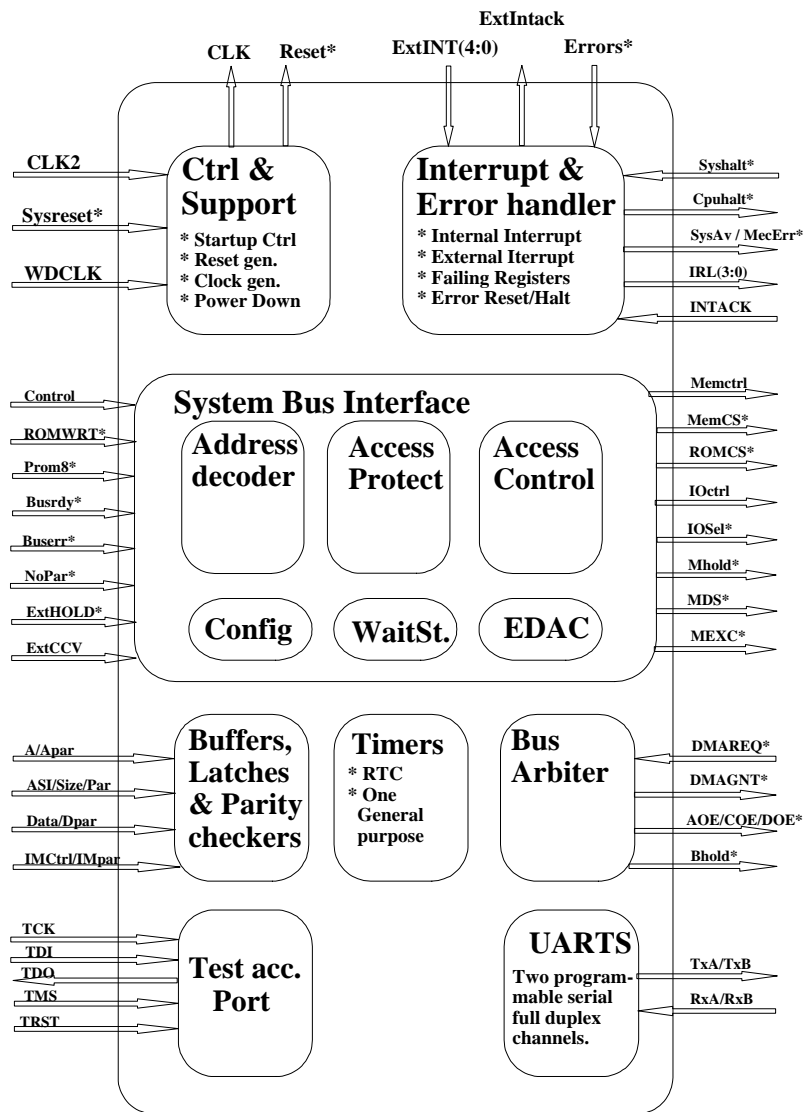

Figure 2 - MEC architecture

3.1. Data Types

Data type definitions follow the SPARC standard version 7. A byte is 8 bits wide, a halfword is 16 bits wide, a word is 32 bits wide, and a double word is 64 bits wide. Organization and addressing of data in memory follow the "Big-Endian" convention wherein lower addresses contain the high-order bytes. For a stored word, address N corresponds to the most significant byte and N+3 corresponds to the least significant byte.

3.2. Memory Interface

3.2.1. Memory Control Signals

The MEC asserts a system address latch enable signal, ALE*, when the IU address or the DMA address is valid. This signal is asserted once in every memory access cycle.

Four buffer enable signals are provided, RAMBEN*, ROMBEN*, MEMBEN* and IOBEN*. RAMBEN* is asserted during RAM access. ROMBEN* is asserted during boot PROM access. MEMBEN* is asserted both during RAM and boot PROM access. IOBEN* is asserted during I/O, Extended general area and exchange memory access.

DDIR and DDIR* are output by the MEC to indicate buffer direction.

As RAM chip select signals MEMCS*(9:0) are provided. The boot PROM chip select signal is ROMCS*. Four I/O device chip select signals are provided, IOSEL(3:0). EXMCS* is used as chip select signal for exchange memory.

For RAM and boot PROM write access two strobe pairs are provided, MEMWR1*(1:0) and MEMWR2*(1:0). MEMWR1* is used to strobe data, D(31:0) into memory. MEMWR2* is used to strobe check bits, CB(6:0) and parity, DPARIO, into memory.

For I/O and exchange memory write access the IOWR* strobe is provided.

As output enable to memory during read access, OE*(1:0) is provided.

BUSRDY* is used to control access cycle length when accessing I/O, exchange memory and extended areas.

BUSERR* is used to signal erroneous access to the MEC when accessing I/O, exchange memory and extended areas.

3.2.2. RAM

The MEC is reprogrammable to interface with a number of different RAM sizes and organisations. The table below shows all possible memory sizes and organisations:

Table 1 - Memory sizes and organizations, using 8-bit wide memory-chips

RAM Size	Chip org. 8 CS used = 32 (+ 8) chips	Chip org. 4 CS used = 16 (+ 4) chips	Chip org. 2 CS used = 8 (+ 2) chips	Chip org. 1 CS used = 4 (+ 1) chips
256 Kbyte	8k chips	16k chips	32k chips	64k chips
512 Kbyte	16k chips	32k chips	64k chips	128k chips
1 Mbyte	32k chips	64k chips	128k chips	256k chips
2 Mbyte	64k chips	128k chips	256k chips	512k chips
4 Mbyte	128k chips	256k chips	512k chips	1M chips
8 Mbyte	256k chips	512k chips	1M chips	2M chips
16 Mbyte	512k chips	1M chips	2M chips	4M chips
32 Mbyte	1M chips	2M chips	4M chips	8M chips

Selection of RAM size is performed by programming the Memory Configuration Register (see page 52). The default value after system reset is 256 Kbytes.

It is possible to divide the selected RAM size into one, two, four, or eight equally sized memory blocks by programming the Memory Configuration Register. The default value after system reset is one block. A memory block is a block composed of 32-bit data, parity bit, and 7-bit check code and controlled with one chip select signal.

The MEC provides eight RAM memory chip selects. One, two, four, or eight chip selects are possible to use corresponding to the programmed number of memory blocks. The default value after system reset is one chip select. The MEC also provides two additional RAM chip selects to handle memory redundancy. See paragraph 3.10.

In the RAM area a store subword (byte or half-word) is implemented as a read-modify-write since check bits must be generated over the whole word, see Figure 3 below.

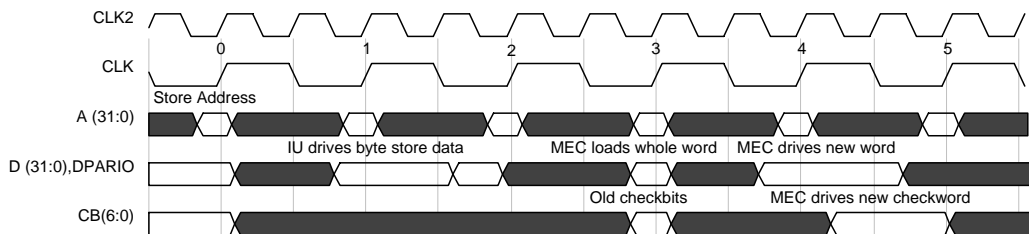

Figure 3 - RAM Store Subword sequence

3.2.2.1. Extended RAM

In addition to the nominal RAM area, an extended RAM area is reserved in the MEC memory map. The MEC does not provide any chip select signals for the extended RAM area, i.e. address decoding must be implemented with external logic. The extended RAM area is BUSRDY* controlled with the same number of waitstates as the RAM

area. In addition, one extra clock cycle is always introduced in the beginning of the cycle for the external address decoding. Byte, halfword and word access is allowed.

3.2.3. Boot PROM

The MEC allows software to be executed from a single byte-wide PROM. Alternatively, a full wide EDAC protected (40 bits) PROM can be used. Hereafter this start-up PROM is called boot PROM.

One extra clock cycle is always introduced in the beginning of the cycle for the address decoding. The IU supports byte operations on data, but for instruction fetches it needs a full 32 bit wide word. In the case that byte-wide boot PROM is used (selected by asserting the PROM8* input pin of the MEC), the MEC performs an 8 to 32 bit conversion of the boot PROM data during read access. This means that a word access to byte-wide boot PROM will correspond to four byte fetches. The total number of cycles required for each word read will then be equal to $4 \cdot (1 + \text{no. of boot PROM waitstates}) + 2$.

When 32-bit wide PROM is used both EDAC and parity bits **must** be supplied to the MEC.

During read operations, byte, halfword and word access is allowed. If the boot PROM is based on EEPROM devices, the MEC supports write access, but note that only byte write is supported if byte-wide EEPROM is used. The write access possibility is enabled by asserting the Prom Write Control signal (ROMWRT*).

The following sizes of the boot PROM are allowed: 128 Kbytes, 256 Kbytes, 512 Kbytes, 1 Mbytes, 2 Mbytes, 4 Mbytes, 8 Mbytes and 16 Mbytes. Selection of PROM size is to be performed by programming the **Memory Configuration Register** (see page 51). The default size of the boot PROM after system reset is the minimum size, 128 Kbytes. The MEC provides one PROM chip select output.

3.2.3.1. Extended PROM

In addition to the boot PROM area, an extended PROM area is reserved in the MEC memory map. The MEC does not provide any chip select signals for the extended PROM area, i.e. address decoding must be implemented with external logic. The extended PROM area is BUSRDY* controlled with the same number of waitstates as the boot PROM area. In addition, one extra clock cycle is always introduced in the beginning of the cycle for the external address decoding. The number of cycles is however always at least two even if the PROM area waitstate value has been programmed to zero. The same restrictions as for boot PROM apply regarding data width and write access.

3.2.4. Exchange Memory

The MEC supports a dedicated exchange memory area that can be used for system bus interchange of data.

The following sizes of the exchange memory are allowed: 4 Kbytes, 8 Kbytes, 16 Kbytes, 32 Kbytes, 64 Kbytes, 128 Kbytes, 256 Kbytes, and 512 Kbytes. Selection of exchange memory size is done by programming the **Memory Configuration Register** (see page 52). The default value of the exchange memory size after system reset is the minimum size, 4 Kbytes. The MEC provides one exchange memory chip select output.

Only word access is allowed in the exchange memory area. Any attempt to access byte or halfword data in the exchange memory will cause a memory exception.

In case the exchange memory includes EDAC check bits and parity bits, these protection bits will be treated in the same manner as for the main memory. If the exchange memory does not include any check bits, the MEC will generate the parity to the IU. The default is that no EDAC or parity is implemented in the exchange memory. If the exchange memory implements check bits, this must be defined in the **Memory Configuration Register** in the MEC during start up and initialization.

The MEC is designed to allow implementation of the exchange memory with a DPRAM. The BUSY signal from the DPRAM can then be connected to the BUSRDY* signal of the MEC. The MEC waits one cycle at the start of the access for the assertion of the BUSRDY* signal. If the BUSRDY* signal is asserted in the beginning of the second cycle, the normal data wait-state controlled access continues. If the BUSRDY* signal is deasserted during the wait-states, the MEC will delay the access until the BUSRDY* signal has been asserted and then continue with the normal data wait-state controlled access. If a cycle is prolonged to more than 256 clock cycles, the Bus Timeout function will signal a system bus error.

The minimum length of an exchange memory access is three clock cycles.

3.2.5. I/O

Four address decoded I/O select outputs are provided in the MEC.

The minimum length of an I/O access for each I/O select is programmable in the MEC. The BUSRDY* signal is used to prolong I/O access for devices with variable access time. The BUSERR* signal is used to signal to the MEC that a bus error has occurred.

Table 2 gives the encoding for the system bus transaction response signals. The transactions that signal a system bus error, set the corresponding bit in the **System Fault Status Register** (SFSR) of the MEC, which then responds by asserting Error to the interrupt logic. These bits describe system bus error cases, in addition the bus timeout is set if the internal bus time out timer causes abortion.

Table 2 - Bus Transaction Response Signals

BUSERR*	BUSRDY*	Action
H	H	Nothing (not ready)
H	L	Data Strobe (ready)
L	H	Nothing (not ready)
L	L	System Bus Error

* denotes an active low signal

An I/O cycle which is to be extended beyond that of the number of wait-states set in the MEC for the corresponding I/O select output, requires that the BUSRDY* signal is deasserted as input to the MEC. The BUSRDY* signal must be deasserted no later than the number of system clock cycles equal to the wait-states set in the MEC after start of the access.

The actual length of an IO cycle will equal the number of programmed waitstates, possibly extended a number of clock cycles by deassertion of the BUSRDY* signal. If a cycle is prolonged to more than 256 clock cycles, the Bus Timeout function will signal a system bus error. As the BUSRDY* signal is used to extend the IO cycle, one waitstate is minimum for I/O access. Programming the no. of IO waitstates to zero will have no effect, i.e. one waitstate is inserted anyway.

Each I/O unit is enabled by programming the **I/O Configuration Register** (see page 54). The default value after system reset is no I/O unit enabled.

Each of the four I/O units is programmable to following sizes: 512 bytes, 1 Kbyte, 2 Kbytes, 4 Kbytes, 8 Kbytes, 16 Kbytes, 32 Kbytes, 64 Kbytes, 128 Kbytes, 256 Kbytes, 512 Kbytes, 1 Mbyte, 2 Mbytes, 4 Mbytes, 8 Mbytes, 16 Mbytes.

Selection of each individual I/O unit size is performed by programming the **I/O Configuration Register** (see page 54). The default value after system reset is 512 bytes for all units.

In case the I/O unit includes a parity bit, the parity will be treated in the same manner as for the main memory. If the I/O unit does not include parity, the MEC will generate parity to the IU. The **I/O Configuration Register** (see page 54) is used to determine for each individual I/O unit if the MEC shall use parity checking and generation. The default is no parity is implemented for the I/O units.

Since the I/O unit never includes EDAC check bits, the store subword (half-word or byte) instruction in the I/O area is different from the store subword in the RAM area. In the RAM area a store subword is implemented as a read-modify-write since check bits must be generated over the whole word. In the I/O area a store subword is implemented as a store word from a timing point of view, but the subword (byte or halfword) is repeated by the IU on the other subwords in the full word, see Figure 4.

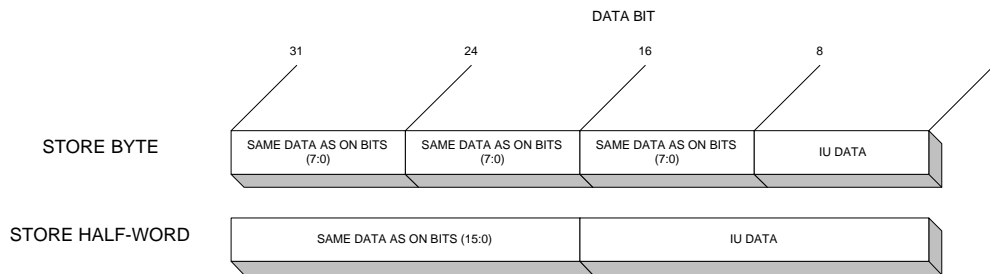

Figure 4 - Store Subword Data Layout

3.2.5.1. Extended I/O

In addition to the nominal I/O area, an extended I/O area is reserved in the MEC memory map. The MEC does not provide any chip select signals for the extended I/O area, i.e. address decoding must be implemented with external logic. The extended I/O area is BUSRDY* controlled with the same number of waitstates as the nominal I/O area. The number of waitstates is however always at least one even if the I/O area waitstate value has been programmed to zero. The same no. of waitstates and parity option as for I/O area 3 apply.

3.2.6. MEC Memory Map

The MEC memory map is shown in Table 3.

Table 3 - MEC Memory map

Address (hexadecimal)	Memory contents	Size (Bytes)	Data size and parity options
0x00000000	Boot PROM	128k - 16M	* 8-bit mode 8 to 32 bit conversion No parity Only byte write * 40-bit mode Parity+EDAC mandatory Only word write
0x01000000	<i>Extended PROM area BUSRDY* controlled¹⁾</i>	15M	<i>The same settings as for Boot PROM</i>
0x01F00000	<i>Exchange memory BUSRDY* controlled</i>	4k - 512k	<i>Parity/EDAC options Only word accesses</i>
0x01F80000	MEC Registers	512k (136 used)	Parity only Word write and Word/ Hword/ Byte read
0x02000000	RAM Memory (8 blocks)	8 * 32k - 8 * 4M	Parity/EDAC options All data sizes allowed
0x04000000	<i>Extended RAM area BUSRDY* controlled¹⁾</i>	192M	<i>The same settings as for RAM Memory</i>
0x10000000	I/O area 0	0 - 16M	Parity option All data sizes allowed
0x11000000	I/O area 1	0 - 16M	As above
0x12000000	I/O area 2	0 - 16M	As above
0x13000000	I/O area 3	0 - 16M	As above
0x14000000	<i>Extended I/O area BUSRDY* controlled¹⁾</i>	1728M	<i>The same settings as for I/O area 3</i>
0x80000000	<i>Extended general area BUSRDY* controlled¹⁾</i>	2G	<i>No parity/EDAC All data sizes allowed</i>

1) Neither access protection nor chip select generation is performed by the MEC for the extended areas. Note that these areas are only controlled by the BUSRDY* signal.

In the *I/O areas* and in the *Extended areas* one waitstate is always inserted, since the MEC has to wait for the BUSRDY* signal. In the *Exchange Memory area* two waitstates are always inserted to wait for the BUSRDY* signal. In the *I/O areas* and in the *Extended areas* the BUSRDY* signal works as a ready signal to tell the accessing unit that data is ready. In the *Exchange Memory area* the BUSRDY* signal works as a busy signal to tell the accessing unit that the access can not yet start.

3.3. DMA Interface

The MEC supports Direct Memory Access (DMA). The DMA unit requests access to the processor bus by asserting the DMA request signal, DMAREQ*. When the DMA unit receives the DMAGNT* signal in response, the processor bus is granted. In case the processor is in the power down mode the IU is permanent three-stated, and a DMAREQ* will directly give a DMAGNT*. The detailed timing for DMA accesses is defined in Appendix A.

It is possible to enable/disable DMA access to the system bus by programming the **MEC Control Register** (see page 51). The default status after system reset is DMA enabled (i.e. permitted).

If DMA is enabled, the MEC asserts BHOLD* and deasserts AOE*, COE*, and DOE* following an DMA Request and then asserts DMA Grant.

A memory cycle started by the processor is not interrupted by a DMA access before it is finished. The following signals shall be used by the DMA unit during the access:

- DMAREQ* to be generated by the DMA unit asking for access
- DMAGNT* generated by the MEC when DMA access is granted
- SYSCLK from the MEC to be used as synchronizing clock
- A[31:0], ASI[3:0] address and SIZE[1:0], WRT, WE*, RD, DXFER, LDSTO, LOCK to be generated by the DMA unit.
- SIZE0 and SIZE1, to be driven by the DMA during DMA transfers. Note that only word transfers are allowed in DMA mode, which means that the values of the size bits must always be driven to SIZE0 = 0 and SIZE1 = 1 in DMA mode.
- APAR, ASPAR and IMPAR parity bits, to be generated by the DMA unit in case parity is enabled for the DMA
- D[31:0] data generated by the DMA unit in case of write cycle or fetched by the DMA unit during read cycle
- DPARIO, data parity, to be generated and possibly checked by the DMA unit in case parity is enabled for the DMA
- DMAAS line used for address strobe to be generated by the DMA unit when the address is valid. Assertion of this signal will initiate the memory access.
- DRDY* line used for indicating data ready for the DMA unit or data written on write. It is generated by the MEC
- MEXC* generated by the MEC indicating a memory access exception when no valid data can be supplied from the memory system, e.g. access violation or error.

If no subsequent DMA cycles are to be issued the DMA unit shall remove the DMAREQ* signal as soon as it has fetched the data on read after that it has received

DRDY*, or when DRDY* is removed on write. The MEC will then remove the DMAGNT* signal.

It is possible to enable/disable DMA parity by programming the **MEC Control Register** (see page 54). The default status after system reset is that DMA parity is disabled. If DMA parity is enabled it has to be generated during write and possibly checked by the DMA during read. If DMA parity is not enabled the MEC generates the parity bit to be stored in the memory in case of write accesses.

Memory access protection is active also during DMA, i.e. attempted write access to protected memory segments will lead to a memory exception, depending on how the ASI bits are driven by the DMA unit (user or supervisor mode).

Normally, the same restrictions apply to DMA access of MEC registers as for the IU in User mode, see page 49. However during system halt (i.e. CPUHALT signal active), the DMA has the same access rights as the IU in supervisor mode for MEC register access. With register write access, memory protection could be changed to permit DMA to access all areas.

The MEC includes a DMA session timeout function preventing the DMA unit to lockout the IU/FPU by asserting DMAREQ* for a long time. If the DMA Request input is not deasserted within 1024 system clock cycles after the assertion of DMA Grant, the memory exception output is asserted and the DMA Grant is removed. The DMA session timeout function is possible to enable or disable by programming the **MEC Control Register** (see page 54). After system reset the timeout function is enabled.

Note that the DMA session timeout function is not the same as a bus timeout, rather an session scheme timeout. In case of a bus timeout during DMA, the MEC asserts the Memory Exception output and removes the Bus Grant. For further actions taken see paragraph 3.17.

3.4. Bus Arbiter

The IU and the FPU always have the lowest priority to the system bus and are denied access to memory in case of a request from a DMA unit, unless the IU is performing a locked access or after a DMA exception cycle to allow interrupt handling.

Thus the DMA is granted access to the system bus provided this has been enabled by the IU in the MEC. In other words the IU has the capability to prevent DMA accesses by disabling DMA in the MEC.

3.5. Execution Modes

The execution modes of the ERC32 as controlled by the MEC is shown in Figure 5.

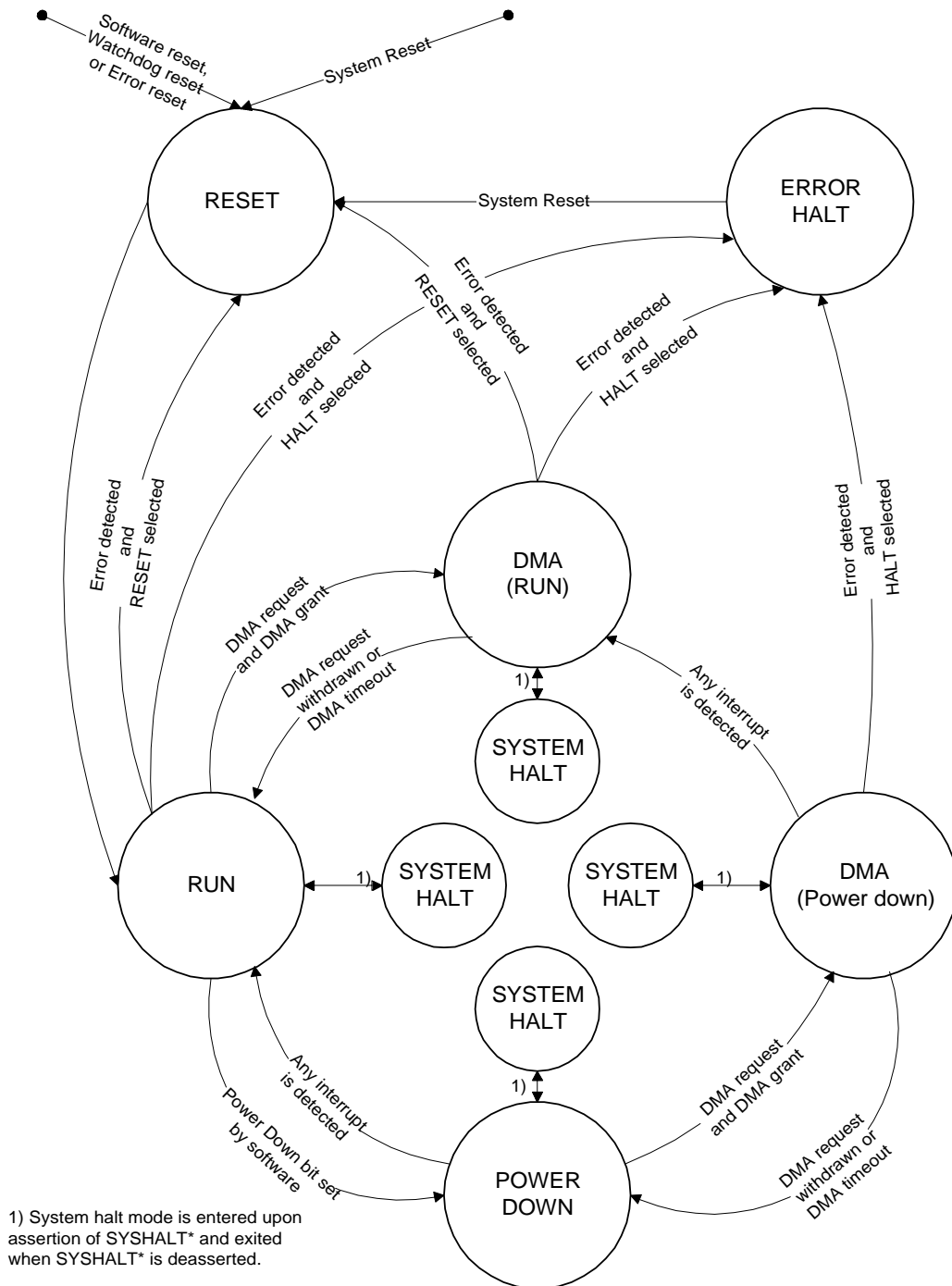

Figure 5 - ERC32 Execution Modes

3.5.1. Reset Mode

When the SYSRES* input is asserted, the MEC issues a reset of itself and asserts the RESET* output which is intended be used as reset signal to all other components in the system (e.g. IU and FPU). The SYSRES* signal shall be applied for at least four clock cycles.

After the assertion of SYSRES*, the MEC starts the ERC32 system in the reset mode which means that all MEC registers will be initialized to their reset contents.

The reset signal from the MEC to the IU/FPU etc., RESET*, is minimum 16 clock cycles long, i.e. it will remain asserted 16 system clock cycles after SYSRES* has been deasserted.

Reset mode is also entered when the RESET* output of the MEC is asserted from any other reason than SYSRES* :

- Software reset which is caused by the software writing to a **Software Reset Register** (see page 52).
- Watchdog reset which is caused by a Watchdog counter timeout (see paragraph 3.14.)
- Error reset which is caused by a hardware parity error, EDAC uncorrectable error or a comparison error (see paragraph 3.17.)

When the reset cause is one of the above, all MEC registers will be initialized to their reset contents except the **Error and Reset Status Register** (see page 61) which contains the source of the last processor reset (System reset, software reset, error reset, watch dog reset). By reading that register upon reset, the IU can determine the cause of the reset.

3.5.2. Run Mode

In this mode the IU/FPU is executing, all timers of the MEC are running (if software enabled) and the UART is running.

3.5.3. System Halt Mode

System Halt mode is entered when the SYSHALT* input of the MEC is asserted. The CPUHALT* output is asserted, freezing IU/FPU execution. All timers are halted and the UART operation is stopped.

The MEC allows DMA accesses during system halt mode, in which DMA has permanent access to the system, i.e. DMAGNT* is asserted immediately on DMA request.

When SYSHALT* is deasserted, the previous mode is entered.

3.5.4. Power-Down Mode

This mode is entered by writing to the **Power Down Register** (see page 52) in the MEC, which will cause the MEC bus arbiter to remove the bus ownership from the IU. The entering of power-down mode must first be permitted by programming the **MEC Control Register** (see page 51).

In power-down mode the MEC asserts and maintains the BHOLD* and deasserts and maintains the AOE*, COE*, and DOE* output signals. If an external interrupt is asserted whilst being in power down mode the MEC deasserts the BHOLD* and asserts the AOE*, COE*, and DOE* output signals. And thereafter ensures that all data at all inputs to the IU/FPU are the same as it was before BHOLD* was asserted. The IU gets back the bus ownership and the MEC leaves the power-down mode.

The MEC allows DMA accesses during power-down mode, in which DMA has permanent access to the system, i.e. DMAGNT* is asserted immediately on DMA request.

3.5.5. Error Halt Mode

Error Halt mode is entered under the following circumstances:

- A hardware parity error, EDAC uncorrectable error or a comparison error (see paragraph 3.17.) has occurred.
- The IU enters error mode (by asserting the ERROR* output)

In Error Halt mode, the CPUHALT* and SYSERR* outputs of the MEC are asserted (note that SYSERR* is also asserted if a masked error occurs even though Error Halt mode is not entered in this case). All timers are halted and the UART operation is stopped in this mode. The only way to exit Error Halt Mode is through Cold Reset by asserting SYSRES*.

The MEC allows DMA accesses during error halt mode, in which DMA has permanent access to the system, i.e. DMAGNT* is asserted immediately on DMA request.

Error Halt Mode can be induced by software by first setting the EWE bit in the **Test Control Register** (see page 61) and then write an error to the **Error and Reset Status Register** (see page 61). Note however that this also requires that the Reset/Halt bit for the chosen error is set to halt in the **MEC Control Register**.

3.6. Wait-State and Timeout Generator

It is possible to control the wait state generation by programming a **Waitstate Configuration Register** (see page 55) in the MEC. The maximum programmable number of wait-states is applied as default at reset.

It is possible to program the number of wait states for the following combinations:

- RAM read
- RAM write
- PROM read
- PROM write (i.e. EEPROM write)
- ExM read/write (i.e. Exchange memory read/write)
- Four individual I/O peripherals read/write

The MEC supports wait state generation by asserting the MHOLD* output in the second memory access cycle.

On exchange memory accesses the MEC will sense the bus ready signal (BUSRDY*) after the first two cycles of the access. If the bus ready signal is asserted at this time the MEC will continue with the programmed no. of wait states. However, if the bus ready signal is deasserted, the start of the access is put on hold. Once the bus ready signal is asserted again, the access will start with the programmed no. of waitstates.

On I/O and extended area accesses the MEC will sense the bus ready signal (BUSRDY*) after the first cycle of the access. If the bus ready signal is asserted at this time the MEC will continue with the programmed no. of wait states. If the bus ready signal is deasserted at this time, the MEC will introduce wait states until the bus ready signal is again asserted.

Note the difference between wait state handling for exchange memory and wait state handling for I/O. For exchange memory, the access will *start* when BUSRDY* is asserted, i.e. after BUSRDY* is asserted an access with the programmed no. of wait states will be performed. BUSRDY* is then handled as for the I/O and extended area. On the other hand, during I/O and extended area access, assertion of BUSRDY* signals the *end* of the access, i.e. the access will finish one cycle after BUSRDY* has been asserted (at the earliest after the programmed no. of wait states).

A bus timeout function of 256 or 1024 system clock cycles is provided for the bus ready controlled memory areas, 256 system clocks in the Extended RAM, Extended General and Extended I/O areas and 1024 system clocks in the Extended PROM area. The **MEC Control Register** (see page 51) is used to select this function. The default after system reset is that the bus timeout function is enabled.

The bus timeout counter will start when the access is initiated. If the bus ready signal is not asserted before a valid number of system clock cycles, a memory exception will occur. For further actions taken see paragraph 3.17.

3.7. Memory Access Protection

3.7.1. Unimplemented Areas

Accesses to all unimplemented memory areas are handled by the MEC and detected as illegal, according to Table 3 (page 18). The memory and I/O configuration registers define the size of memory and I/O areas. The unused area of the memory space, dependent on the programming of the memory size, is decoded as illegal.

If an access from the IU is attempted to an illegal area, the memory exception output is asserted. If an access from the DMA is attempted to an illegal area, the memory exception output (MEXC*) and the DMA access error interrupt output are asserted.

For the extended areas no access protection is implemented. However, since these areas are bus ready(BUSRDY*) controlled the bus timeout function will detect an access to an unimplemented extended area.

When the IU issues the trap service routine, the contents of the MEC **System Fault Status Register** (SFSR) give the cause of the exception.

When a memory data access violation error occurs (RAM write protection or illegal area) the associated bus address is latched in a separate register, MEC **Failing Address Register** (FAR). With memory data access is meant IU operand fetch or DMA. An IU instruction fetch error will not latch the bus address.

For further actions taken see paragraph 3.17.

3.7.2. RAM Write Access Protection

In addition to the access protection defined by the fixed memory map in the MEC which will detect any access to unimplemented and illegal addresses, the MEC can be programmed to detect and mask write accesses in any part of the RAM. The protection scheme is enabled *only for data area*, not for the instruction area.

The programmable write access protection is segment based. A segment defines an area where write cycles are allowed. Any write cycle outside a segment is trapped and does not change the memory contents. Two segments are implemented. Each segment is implemented with two registers: the **Segment Base Register** and the **Segment End Register**. The segment base register contains the start address of the segment, and enabling bits for supervisor/user mode (SE/UE). The segment end register contains the first address outside the segment, i.e. last address of segment plus one word. Only word aligned addresses are supported. The segments are only active during RAM access, i.e. they can only be mapped to the RAM area.

If both the SE and UE bits of the **Segment Base Register** are cleared, write protection is effectively disabled for that segment.

The segment access protection can also be used as a block protect function by setting the BP bit in the **MEC Control Register**. The BP bit inverts the address criterion for the protection function so that any access *within* the segment is detected.

If a write access protection error is detected a memory exception is generated and the **SFSR** and **Failing Address Register** is updated as for unimplemented area accesses, see also paragraph 3.17.

In normal mode, (BP=0), a memory exception is generated only if *both* segments indicated a write protection error. In block protect mode (BP=1), a memory exception is generated if *any* of the segments indicate a write protection error.

3.7.3. Boot PROM Write Protection

The MEC supports PROM write only when it is qualified by the external enable signal ROMWRT and the enable bit in the **Memory Configuration Register** (see page 52). The MEC only supports byte write operations for an 8-bit wide PROM and only word write operations for a 40-bit wide PROM.

If a write access to PROM is attempted when any of the above conditions are not fulfilled, the **SFSR** and **Failing Address Register** is updated as for unimplemented area accesses, see also paragraph 3.17.

3.8. Register Access Protection

All MEC registers except the UART RX and TX registers are readable in all access modes: user, supervisor, and DMA. The UART RX and TX registers are only readable in supervisor mode. The MEC allows word, halfword and byte accesses when a register is read. The total 32-bit data (together with the parity bit) are thus always issued on the data bus.

All MEC registers which are writeable, are writeable only in supervisor mode or in DMA mode if the CPUHALT* is active and only as full 32-bit size data write accesses to the registers.

If a register access violation is performed by the IU, the memory exception output is asserted. If a register access violation is performed by the DMA, the memory exception output (MEXC*) and the DMA access error interrupt output are asserted.

3.9. EDAC

The MEC includes a 32-bit EDAC (Error Detection And Correction). Seven bits (CB[6:0]) are used as check bits over the data bus. The Data Bus Parity Input/Output signal (DPARIO) is used to check and generate the odd parity over the 32-bit data bus. This means that altogether 40 bits are used when the EDAC is enabled.

The MEC EDAC uses a seven bit Hamming code which detects any double bit error on the 40-bit bus as a non-correctable error. In addition, the EDAC detects all bits stuck-at-one and stuck-at-zero failure for any nibble¹ in the data word as a non-correctable error. Stuck-at-one and stuck-at-zero for all 32 bits of the data word is also detected as a non-correctable error.

The EDAC corrects any single bit data error on the 40-bit bus. However, in order to correct any error in memory (e.g. Single Event Upset induced) the data has to be read and re-written by software as the MEC does not automatically write back the corrected data.

¹ A nibble is defined as a bit group of four within the data word, D(3:0), D(7:4) etc.

3.9.1. Check Bit Generator

The Check Bit Generator generates the seven check bits plus parity bit that is to be fed to a multiplexer. The output from the multiplexer is either the check bits generated by the Check Bit Generator or the contents of the check bits in the **Test Control register**.

(CB = checkbit, DPARIO = parity bit)

$$\text{CB0} = \text{D31 xor D30 xor D29 xor D28 xor D24 xor D21 xor D20 xor D19 xor D15 xor D11 xor D10 xor D09 xor D08 xor D05 xor D04 xor D01}$$

$$\text{CB1} = \text{D30 xor D28 xor D25 xor D24 xor D20 xor D17 xor D16 xor D15 xor D13 xor D12 xor D09 xor D08 xor D07 xor D06 xor D04 xor D03}$$

$$\text{CB2} = \text{not (D31 xor D26 xor D22 xor D19 xor D18 xor D16 xor D15 xor D14 xor D10 xor D08 xor D06 xor D05 xor D04 xor D03 xor D02 xor D01)}$$

$$\text{CB3} = \text{D31 xor D30 xor D27 xor D23 xor D22 xor D19 xor D15 xor D14 xor D13 xor D12 xor D10 xor D09 xor D08 xor D07 xor D04 xor D00}$$

$$\text{CB4} = \text{not (D30 xor D29 xor D27 xor D26 xor D25 xor D24 xor D21 xor D19 xor D17 xor D12 xor D10 xor D09 xor D04 xor D03 xor D02 xor D00)}$$

$$\text{CB5} = \text{D31 xor D26 xor D25 xor D23 xor D21 xor D20 xor D18 xor D14 xor D13 xor D11 xor D10 xor D09 xor D08 xor D06 xor D05 xor D00}$$

$$\text{CB6} = \text{D31 xor D30 xor D29 xor D28 xor D27 xor D23 xor D22 xor D19 xor D18 xor D17 xor D16 xor D15 xor D11 xor D07 xor D02 xor D01}$$

$$\text{DPARIO} = \text{Odd parity over D31 to D0} = \text{not (D31 xor D30 xor ... xor D01 xor D00)}$$

3.9.2. Syndrome Generator

The Syndrome Generator generates the internally used and externally observable syndrome bits (SY(7:0)). It uses the read data bits and the eight read check bits. The coding of the syndrome is given below:

$$\text{SY7} = \text{CB6(Read Data)} \text{ xor } \text{CB5(Read Data)} \text{ xor } \text{not}(\text{CB4(Read Data)}) \text{ xor } \text{CB3(Read Data)} \text{ xor } \text{not}(\text{CB2(Read Data)}) \text{ xor } \text{CB1(Read Data)} \text{ xor } \text{CB0(Read Data)} \text{ xor } \text{Read Parity}$$

$$\text{SY6} = \text{CB6(Read Data)} \text{ xor } \text{Read Checkbit6}$$

$$\text{SY5} = \text{CB5(Read Data)} \text{ xor } \text{Read Checkbit5}$$

$$\text{SY4} = \text{CB4(Read Data)} \text{ xor } \text{Read Checkbit4}$$

$$\text{SY3} = \text{CB3(Read Data)} \text{ xor } \text{Read Checkbit3}$$

$$\text{SY2} = \text{CB2(Read Data)} \text{ xor } \text{Read Checkbit2}$$

$$\text{SY1} = \text{CB1(Read Data)} \text{ xor } \text{Read Checkbit1}$$

$$\text{SY0} = \text{CB0(Read Data)} \text{ xor } \text{Read Checkbit0}$$

3.9.3. Syndrome Detector

If there is a correctable error in the read data word, the correction is performed according to the following procedure:

In case of Syndrome(7:0)

```
when "00111000" => Corrected Data = Data xor "00000000000000000000000000000001"
when "01000101" => Corrected Data = Data xor "00000000000000000000000000000010"
when "01010100" => Corrected Data = Data xor "00000000000000000000000000000100"
when "00010110" => Corrected Data = Data xor "000000000000000000000000000001000"
when "00011111" => Corrected Data = Data xor "0000000000000000000000000000010000"
when "00100101" => Corrected Data = Data xor "00000000000000000000000000000100000"
when "00100110" => Corrected Data = Data xor "000000000000000000000000000001000000"
when "01001010" => Corrected Data = Data xor "0000000000000000000000000000010000000"
when "00101111" => Corrected Data = Data xor "00000000000000000000000000000100000000"
when "00111011" => Corrected Data = Data xor "000000000000000000000000000001000000000"
when "00111101" => Corrected Data = Data xor "0000000000000000000000000000010000000000"
when "01100001" => Corrected Data = Data xor "0000000000000000000000000000010000000000"
when "00011010" => Corrected Data = Data xor "00000000000000000000000000000100000000000"
when "00101010" => Corrected Data = Data xor "000000000000000000000000000001000000000000"
when "00101100" => Corrected Data = Data xor "0000000000000000000000000000010000000000000"
when "01001111" => Corrected Data = Data xor "0000000000000000000000000000010000000000000"
when "01000110" => Corrected Data = Data xor "00000000000000000000000000000100000000000000"
when "01010101" => Corrected Data = Data xor "00000000000000000000000000000100000000000000"
when "01100100" => Corrected Data = Data xor "000000000000000000000000000001000000000000000"
when "01011101" => Corrected Data = Data xor "000000000000000000000000000001000000000000000"
when "00100011" => Corrected Data = Data xor "0000000000000000000000000000010000000000000000"
when "00110001" => Corrected Data = Data xor "0000000000000000000000000000010000000000000000"
when "01001100" => Corrected Data = Data xor "00000000000000000000000000000100000000000000000"
when "01101000" => Corrected Data = Data xor "00000000000000000000000000000100000000000000000"
when "00010011" => Corrected Data = Data xor "000000000000000000000000000001000000000000000000"
when "00110010" => Corrected Data = Data xor "0000000000000000000000000000010000000000000000000"
when "00110100" => Corrected Data = Data xor "00000000000000000000000000000100000000000000000000"
when "01011000" => Corrected Data = Data xor "000000000000000000000000000001000000000000000000000"
when "01000011" => Corrected Data = Data xor "0000000000000000000000000000010000000000000000000000"
when "01010001" => Corrected Data = Data xor "00010000000000000000000000000000000000000000"
when "01011011" => Corrected Data = Data xor "00100000000000000000000000000000000000000000"
when "01101101" => Corrected Data = Data xor "01000000000000000000000000000000000000000000"
when "00000000" => Corrected Data = Data xor "1000000000000000000000000000000000000000"
when "10000000" => Corrected Data = Data xor "0000000000000000000000000000000000000000" (no error)
```

A correctable error is detected if

Syndrome(7:0) = "00111000" | "01000101" | "01010100" | "00010110" | "00011111"
 | "00100101" | "00100110" | "01001010" | "00101111" | "00111011"
 | "00111101" | "01100001" | "00011010" | "00101010" | "00101100"
 | "01001111" | "01000110" | "01010010" | "01100100" | "01011101"
 | "00100011" | "00110001" | "01001100" | "01101000" | "00010011"
 | "00110010" | "00110100" | "01011000" | "01000011" | "01010001"
 | "01011011" | "01101101" | "00000000" | "10000001" | "10000010"
 | "10000100" | "10001000" | "10010000" | "10100000" | "11000000".

The non correctable error is detected if

Syndrome(7:0) are not equal to "00111000" | "01000101" | "01010100" | "00010110"
 | "00100101" | "00100110" | "01001010" | "00101111" | "00111011"
 | "00111101" | "01100001" | "00011010" | "00101010" | "00101100"
 | "01001111" | "01000110" | "01010010" | "01100100" | "01011101"
 | "00100011" | "00110001" | "01001100" | "01101000" | "00010011"
 | "00110010" | "00110100" | "01011000" | "01000011" | "01010001"
 | "01011011" | "01101101" | "00000000" | "10000001" | "10000010"
 | "10000100" | "10001000" | "10010000" | "10100000" | "11000000"
 | "10000000" | "00011111".

3.9.4. Fault Injection

Moved to paragraph 3.19.

3.9.5. Memory and I/O Parity

The MEC handles parity towards memory and I/O in a special way. The MEC can be programmed to use no parity, only parity or parity and EDAC protection towards memory. Towards I/O, the MEC can be programmed to use no parity or only parity.

The signal used for the parity bit is DPARIO. This pin is used by the MEC to check and generate the odd parity over the 32-bit data bus according to Table 4 below.

Table 4 - MEC parity handling

Accessed memory area	Memory parity enabled	Read	Write
RAM and exchange memory	No	G	C
RAM and exchange memory	Yes	C	C
ROM, 8-bit access	No	G	C
ROM, 40-bit access	Yes	C	C
MEC registers	Yes	G	C
IO areas	No	G	C
IO areas	Yes	C	C
Extended general area	No	G	C
DMA access with DMA parity enabled	Yes	C	C
DMA access with DMA parity enabled	No	G	C
DMA access with DMA parity disabled	Yes	C	G
DMA access with DMA parity disabled	No	N	N

G = parity generated, C = parity checked, N= parity not checked nor generated

Note: When a correctable error occurs in the RAM or exchange memory
MEC generates parity (G) even if parity is enabled.

3.10. Memory Redundancy

The MEC dedicates chip selects for two redundant memory banks for replacement of faulty banks. A memory bank is a block composed of 32-bit data, parity and a 7-bit checkcode and controlled with one chip select signal. The size of the redundant memory banks are dependent of the memory size register.

Exclusion of a faulty memory block and selection of a redundant memory block is performed by programming the **Memory Configuration Register** (see page 52). This remapping has no influence on the performance.

3.11. Synchronous Traps

Memory access error are signaled by the MEC by assertion of the MEXC* signal. This event will force the IU to vector to either an instruction access exception or a data access exception, see [RD2].

Upon detecting an instruction or data exception, the IU enters the corresponding trap. The trap handler software can identify the synchronous fault with the aid from the Error Handler functions included in the MEC (see paragraph 3.17.).

The MEC is capable of handling 9 different fault events which all will result in a synchronous trap of the type instruction access exception or data access exception in the IU by assertion of the MEXC* signal.

Parity error on control bus

This occurs if the MEC detects a parity error on the external control bus.

Parity error on the data bus

This trap occurs if the MEC detects a parity error on the external data bus.

Parity error on address bus

This trap occurs if the MEC detects a parity error on the external address bus.

Access to protected area

This trap occurs if any addressing device performs an access which does not match the memory protection scheme.

Access to unimplemented area

This trap occurs if any addressing device performs an access with invalid address to an unimplemented area.

MEC register access violation

This trap occurs if an illegal access is attempted to an internal MEC register.

Uncorrectable error in memory

The trap occurs if the EDAC detects a non-correctable error.

Bus time-out

This trap occurs if the ready generation times out i.e. if, during a BUSRDY* controlled access, BUSRDY* is not asserted within 256 clock cycles.

System bus error

This trap occurs if the Bus error (BUSERR*) input is asserted.

3.12. Interrupts (Asynchronous Traps)

The MEC handles 15 different events corresponding to asynchronous traps.

The MEC allocates each specific interrupt to an interrupt level. The interrupt allocation is in accordance with the scheme in Table 5 (page 35).

The following interrupts, representing asynchronous traps, asserts the Interrupt Request Level (IRL) inputs of the processor:

Watch Dog time-out

This interrupt occurs if the watchdog timer times out.

DMA time-out

This interrupt occurs if the DMA session exceeds permitted time.

DMA access error

This interrupt occurs if the DMA performs an access violation or illegal access.

UART error

This interrupt is generated by the UARTs if an error is detected.

UART A and B Data Ready or Transmitter Ready

These interrupts are generated by the UARTs each time a data word has been correctly received and each time a data word has been sent.

Real Time Clock

This interrupt is issued by the real time clock timer tick.

General purpose timer

This interrupt is issued by the general purpose timer.

Correctable error in memory

This interrupt occurs if the EDAC detects and corrects an error.

Masked Hardware Errors

This occurs when there is a hardware error set in the **Error and Reset Status Register** (see page 61) and the error is masked (an unmasked hardware error leads to an Error Halt or Warm Reset instead of an interrupt, see paragraph 3.5.).

5 external individually prioritized interrupts

The sources of these interrupts are located outside the ERC32. Consequently these interrupts are inputs to the MEC.

The interrupt allocation for the asynchronous traps is in accordance with the scheme in Table 5 (page 35).

It is possible to mask each individual interrupt (except interrupt 15) by setting the corresponding bit in the **Interrupt Mask Register** (see page 57).

The MEC includes a specific register called **Interrupt Pending Register** (see page 56), which reflects the pending interrupts. It is possible to clear pending interrupts by setting the corresponding bit in the **Interrupt Clear Register** (see page 57).

(Interrupt test description moved to paragraph 3.19.)

The interrupts in the IPR are cleared automatically when the interrupt is acknowledged. The MEC will sample the trap address in order to know which bit to clear.

Upon receiving an interrupt, external or forced, the MEC issues a request on its IRL outputs to the IU with the corresponding interrupt level. If two or more interrupts occur

simultaneously, the interrupt with the highest priority level is issued to the IU. If a higher level interrupt is recognized by the MEC before the lower level interrupt request is acknowledged, the higher level interrupt will replace the lower level interrupt request.

By programming the **Interrupt Shape Register** (see page 56), it is possible to define the external interrupts to be either active low or active high and to define the external interrupts to be either edge or level sensitive. Also, by programming the ISR, it is possible to make one of the external interrupts generate a pulse on the EXTINTACK output when the IU acknowledges the interrupt.

The external interrupt inputs are filtered such that both level and edge sensitive interrupts are detected only if the external interrupt is active for at least two system clock cycles.

Edge sensitive interrupts will be detected only when a transition occurs (from high to low if programmed to be active low and vice-versa), i.e. the corresponding bit in IPR will be set.

Level sensitive interrupts will be detected, i.e. the corresponding bit in IPR will be set as long as the interrupt line is asserted. When the interrupt line is deasserted, the corresponding bit in IPR will be cleared.

Table 5 - Interrupt Trap Type and default priority assignments

Trap	Priority	Trap Type	Interrupt level/no
Watch Dog time-out	13	0x1F	15
Ext. Interrupt 4	14	0x1E	14
Real Time Clock	15	0x1D	13
General purpose timer	16	0x1C	12
Ext. Interrupt 3	17	0x1B	11
Ext. Interrupt 2	18	0x1A	10
DMA time-out	19	0x19	9
DMA access error	20	0x18	8
UART error	21	0x17	7
Correctable error in mem.	22	0x16	6
UART B Data Ready or Transmitter Ready	23	0x15	5
UART A Data Ready or Transmitter Ready	24	0x14	4
Ext. Interrupt 1	25	0x13	3
Ext. Interrupt 0	26	0x12	2
Masked Hardware errors	27	0x11	1

3.13. General Purpose and Real Time Clock Timers

Two timers (apart from the special Watchdog timer) are available in the MEC. These timers provide, in addition to a generalized counter mechanisms, a mechanism for setting the step size in which actual time counts are performed (a two-stage counter). Each timer/counter pulse generator consists of two parts:

- pre-SCALER
- COUNTER

SCALER is a counter to adjust the step size in which COUNTER does the actual time count.

COUNTER is a counter to actually count time in steps as set by the value in SCALER. COUNTER is decrements when SCALER reaches zero.

The implementation is shown in Figure 6.

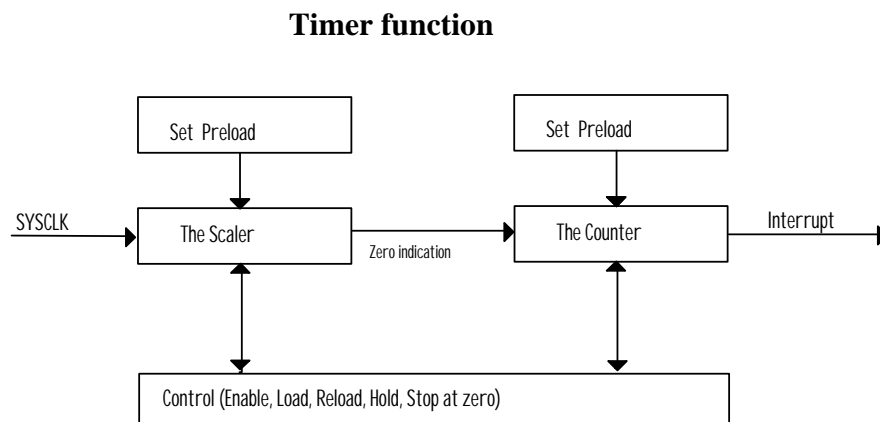

Figure 6 - Timer implementation

Both timers are clocked by the internal system clock. The timers are programmable by writing to the **Timer Control Register** (see page 59). They are possible to program to be either of single-shot type or periodical type, in both cases generate an interrupt when the delay time has elapsed. If the timer is not programmed with a new value when set to periodical type, it restarts from the latest programmed value and continue to count down, thus generating interrupts periodically. The **Real Time Clock Timer** interrupt has higher priority than the **General Purpose Timer** interrupt. It is possible to halt and restart the timers by writing to the **Timer Control Register**. The only functional difference between the two timers is that the **Real Time Clock Timer** has an 8-bit scaler while the **General Purpose Timer** has a 16-bit scaler providing a wider range.

While the signal CPUHALT* is active, the timers are temporary halted.

The **Real Time Clock Timer** (see page 58) is implemented as one down counting 8-bit scaler and one down counting 32-bit counter. The current value of the scaler and counter of the Real Time Clock can be read.

The timer scaler load value is programmable in **Real Time Clock Program Register <Scaler>** (see page 58). The timer count load value is programmable in **Real Time Clock Program Register <Counter>** (see page 58). The value of these registers will not be altered unless reprogrammed or reset. After system reset the Real Time Clock is not running and must be programmed as required.

The **General Purpose Timer** (see page 58) is implemented as one down counting 16-bit scaler and one down counting 32-bit counter. The current value of the scaler and counter of the General Purpose Timer can be read.

The timer scaler load value is programmable in **General Purpose Timer Program Register <Scaler>** (see page 58). The timer count load value is programmable in **General Purpose Timer Program Register <Counter>** (see page 58). The value of these registers will not be altered unless reprogrammed or reset. After system reset the General Purpose Timer is not running and must be programmed as required.

3.14. Watch Dog

The watch dog function consists of a **Watchdog Timer** (see page 57). The watch dog is supplied from a separate external input (WDCLK) which must have a frequency which is at least three times lower than SYSCLK. This input could be divided by 16 in a prescaler or routed directly to the scaler of the watch dog as set in the **MEC Control Register** (see page 51).

The WDCLK input consists of a Schmitt-trigger to allow clock supply from an external RC oscillator.

It is possible to program the timer by setting a specific value in the **Watchdog Program and Timeout Acknowledge Register** (see page 57). The register consists of one scaler field and one counter field corresponding directly to the scaler field and the counter field of the watchdog timer.

After system reset or processor reset, the timer is enabled and starts running. The default value is the scaler set to maximum and the counter set to maximum. By writing to the **Trap Door Set** (see page 57) after system reset, the timer can be disabled. After the disabling of the watch dog timer a write operation to the **Watchdog Program and Timeout Acknowledge Register** (see page 57) starts the timer counting with the value of the specified fields. Note that the Watchdog cannot be disabled once the **Watchdog Program and Timeout Acknowledge Register** has been written.

If the timer is refreshed by writing to **Watchdog Program and Timeout Acknowledge Register** (see page 57) before the counter reaches zero value, the timer restarts the counting with the new delay value. If the timer is not refreshed (reprogrammed) before the counter reaches zero value, an interrupt is issued to the IU. Simultaneously, the timer starts counting a reset timeout period with the programmed delay time. Then, if the timer is acknowledged by writing to **Watchdog Program and Timeout Acknowledge Register** (see page 57) with a new programmed value before the reset timeout period elapses again, the timer restarts counting with the new delay value, but if the timer is not acknowledged before the reset timeout period elapses, a processor reset is issued by the MEC.

The Watchdog is temporary halted when the CPUHALT* signal is active.

Figure 7 explains all the states and transitions of the watchdog timer.

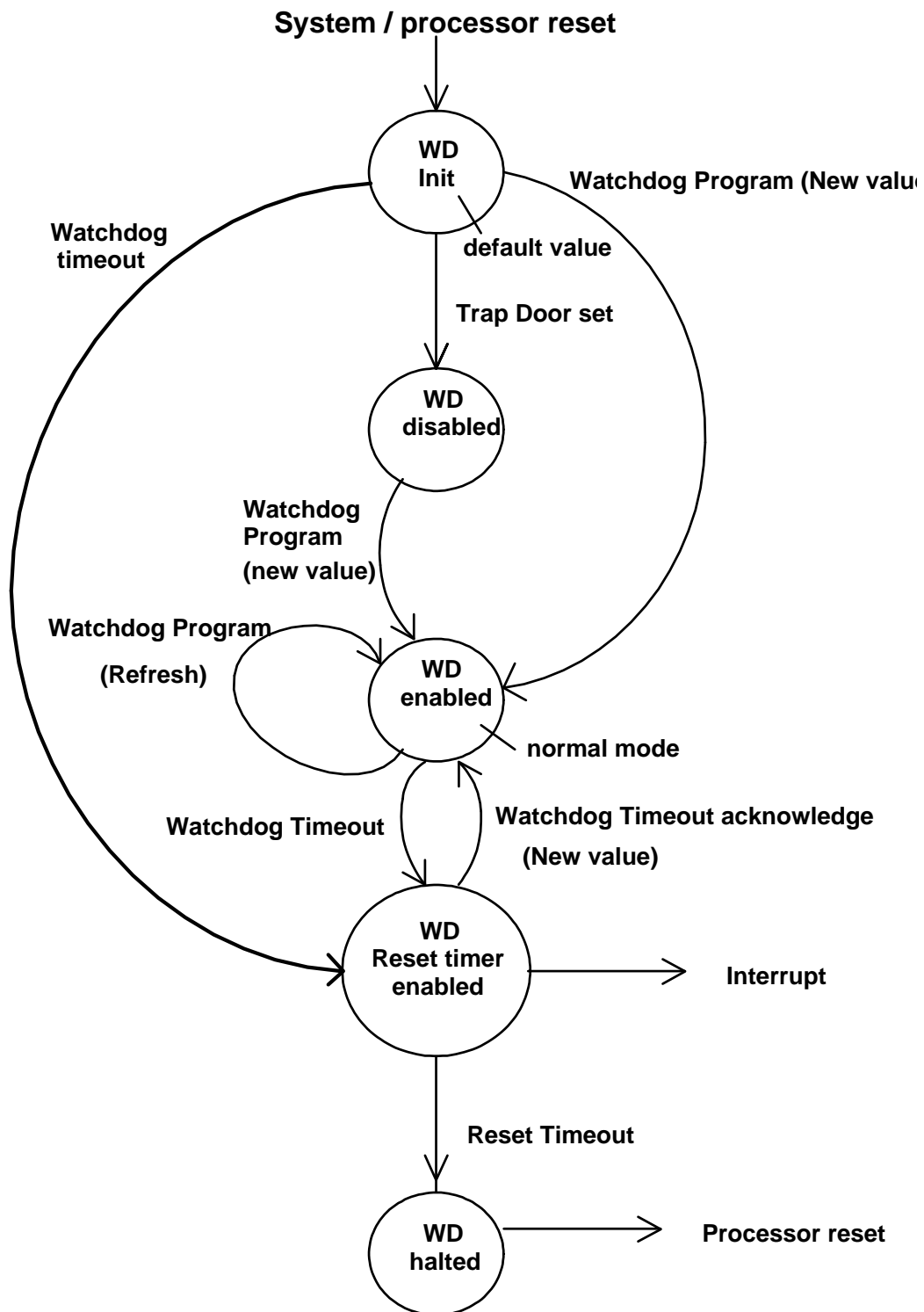

Figure 7 - Watchdog timer states and transitions

3.15. UART

The MEC includes two full duplex asynchronous receiver transmitters (UARTs).

The data format of the UARTs is eight bits. It is possible to choose between even or odd parity, or no parity, and between one and two stop bits by programming the **MEC Control Register** (see page 51). After system reset odd parity and one stop bit are set. The baud rate of the UART is set by programming the **MEC Control Register** (see page 51). After system reset the baud rate is set to system clock frequency divided by 32 which is probably not a usable baud rate. It follows that the baud rate in the **MEC Control Register** must be programmed after system reset.

The UARTs provides double buffering, i.e. each UART consists of a transmitter holding register, a receiver holding register, a transmitter shift register, and a receiver shift register. Each of these registers has a width of 8 bits. For each UART a **RX and TX Register** (see page 62) is provided. There is also a common **UART Status Register** (see page 62).

Figure 9 - removed

The receiver converts serial start bit, data word, parity bit and stop bit(s) into parallel form. The transmitter converts parallel data into serial form automatically adding start bit, parity bit, and stop bit(s).

To output a byte on the serial output the following procedure should be followed. First, the **UART Status Register** should be read in order to check that the transmitter holding register (THE, bit 2 and bit 18 respectively for channel A and B) is empty. Otherwise, the previous byte to be output may be lost (note that the TSE bit is not useful for the purpose of checking if a character may be written to the RX/TX register). Then, the byte to be output (RTD, bits 0-7) is written in the RX and TX register. The byte written will then automatically be transferred to the transmitter send register and converted to serial form also adding start bit, parity bit, and stop bit(s). The above described sequence can be part of a trap handler for the UART interrupt.

When a data byte has been received on the serial interface an interrupt is issued to the IU. The byte received is converted to parallel form and loaded into the receiver data register. Framing error, i.e. the stop bit is not of correct polarity, parity error, and overrun error, i.e. the preceding byte has not been read before a complete following byte is received, are indicated by the bits FE, PE, and OE, respectively in the **UART status register**.

A correctly received byte is indicated by the Data Ready bits for channel A and B (DRA, bit 0 and DRB, bit 16) when reading the **UART status register**.

The UARTs generate an interrupt each time a data word has been received, a data word has been sent, and if an error is detected. There is one interrupt from each UART (A and B) to indicate that data is correctly received or that the transmitter register is empty.

There is another interrupt to indicate errors, but this interrupt is common for both UART channels.

The UART uses an internal clock which is 16 times faster than the baud-rate, and samples each bit 16 times, to ensure error free reception. The clock is derived either from the system clock or can use the watchdog clock with a UART oscillator input.

The baudrate of the UARTs can be programmed in the Scaler field and UBR bit of the **MEC Control Register**. The scaler shall be set to:

$$\text{Scaler} = \frac{\text{Clock}}{32 * \text{Baudrate} * (2 - \text{UBR})} - 1$$

Where Clock is either the frequency of the system clock (SYSCLK) or the watchdog clock (WDCLK) selected by UCS (bit 23 in **MEC Control Register**). UBR is the value of the UBR bit. Baudrate is the desired baudrate. Note that the resulting actual baudrate will probably not be exactly the desired one. This is due to the fact that Scaler is an integer number, and the above given equation may yield a non-integer result, depending on the Clock frequency.

The UART is temporary halted when CPUHALT* is active and no transmission is performed by the UART.

The external UART interfaces consist of one transmit data output for each UART channel (TXA and TXB) and one receive data input for each UART channel (RXA and RXB).

Note that no hardware handshake signals, such as CTS or RTS are implemented. Any handshaking must be implemented in software (e.g. using XON/XOFF).

3.16. Parity Checking

The MEC includes parity checking and generation if required on the external data bus (DPARIO). It includes parity checking on the external address bus (APAR). It also includes parity checking on ASI and SIZE (ASPAR) together with parity generation and checking on all internal registers. The MEC also includes parity generation and checking on the external control bus to the IU (IMPAR). If a parity error is detected on the external data bus, the external address, the external ASI and SIZE, the external control bus, the memory exception output (MEXC*) is asserted. If a memory exception event occurs the **System Fault Status Register** (see page 60) is updated and reflects the type and location of parity errors.

All external parity checking can be disabled using the NOPAR* signal.

3.17. Error Handler

The MEC has one error output signal (SYSERR*) which indicates that an unmasked error has occurred. Any error signaled on the error inputs from the IU and the FPU is latched and reflected in the **Error and Reset Status Register** (see page 61).

It is possible to program an error mask in the **MEC Control Register** for each type of error in order to determine whether the specific error shall lead to the MEC ignoring the error or asserting a processor halt or processor reset. It is possible to choose either a processor halt or processor reset by programming the **MEC Control Register** (see page 51). As default, an error leads to a processor halt.

All unmasked errors, asserts the SYSERR* pin and this pin is asserted until all the unmasked error bits in the **Error and Reset Status Register** (see page 61) are cleared.

In Figure 8 a schematic view of the error handler is shown.

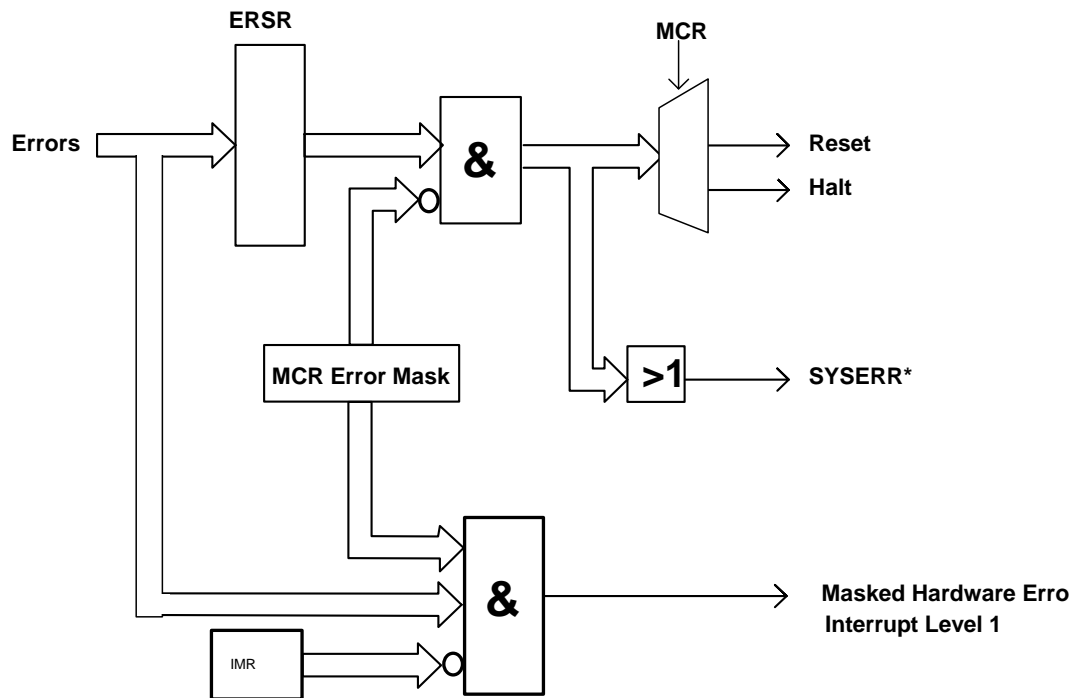

Figure 8 - Error Handler Schematic

A MEC hardware error occurs, if a parity error is detected on the internal registers. A detected MEC hardware error will cause the MEC to assert the MECHWERR* and SYSERR* signals. The memory exception output (MEXC*) is not asserted in this case.

The MEC provides inputs for handling of the following IU and FPU errors (see RD2 and RD3):

- IU Error Mode (IUERR*)
- IU Hardware Error (IUHWERR*)
- IU Comparison Error (IUCMPERR*)
- FPU Hardware Error (FPUHWERR*)
- FPU Comparison Error (FPUCMPERR*)

A detected error on those inputs will cause the MEC to assert the SYSERR* signal. IU, FPU and MEC errors are latched even if previous errors are latched.

The MEC also provides inputs for handling of master/slave checking for the IU/FPU.

In Figure 9 a system is shown where master checkers are used on both the IU and FPU.

Master Checker on IU and FPU

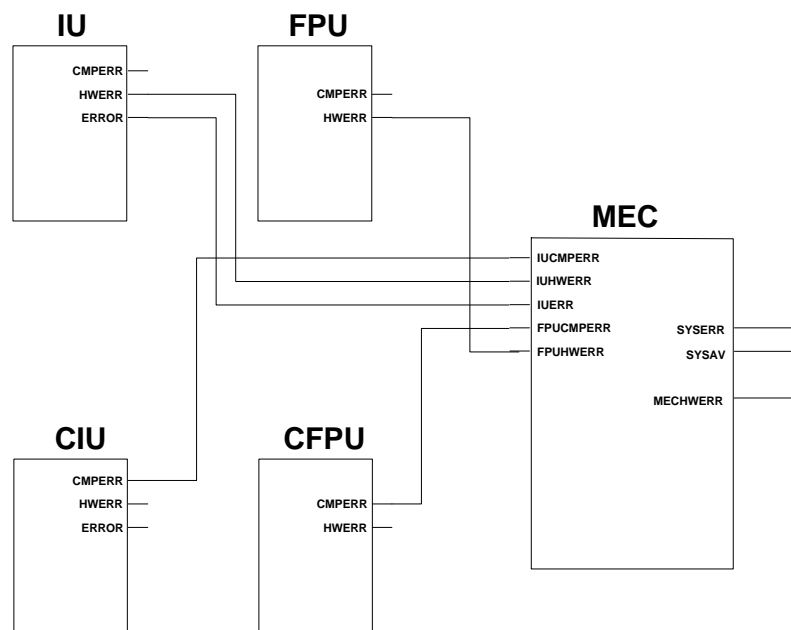

Figure 9 - Master/Slave configuration on IU and FPU

A detected comparison error (CMPERR) from either of the checking devices will cause the MEC to assert the SYSERR* signal if the comparison error is unmasked.

The MEC detects illegal register access, e.g. write to internal register in non supervisor mode. The memory exception output (MEXC*) is asserted by the MEC, if such an access is made or if an access to an internal MEC register with erroneous data size is attempted.

A list of all events (synchronous traps) that cause a MEXC* is found on page 33. Less critical errors and some other events are called asynchronous traps. These events do not cause a MEXC* but only an interrupt. A list of all asynchronous traps is found on page 33. The MEC always completes the current cycle when an error is detected and the MEXC* is generated in the beginning of the next cycle.

Apart from issuing MEXC* and/or interrupt, synchronous and asynchronous events also cause the MEC to latch some internal registers to hold information about the occurred error. If a trap event occurs the **System Fault Status Register** (see page 60) is updated and reflects the type of error in accordance with the conditions in the table. Also the **Error and Reset Status Register** (see page 61) is updated reflecting the type of error in accordance with the conditions in the table. The associated bus address is latched in the **Failing Address Register** (see page 60) in accordance with the conditions in the table.

IU data fault valid and asynchronous fault valid are implemented in the **System Fault Status Register**. DMA errors will not overwrite the **System Fault Status Register** if IU data fault valid bit is set.

If a data access results in an error, the **Failing Address Register** is always updated, even if an error has already been latched before. With data access is meant an IU operand fetch or a DMA, i.e. the ASI bits indicate an ongoing data load/store cycle.

The following figure shows all possible latching scenarios for the **SFSR** and **FAR** registers.

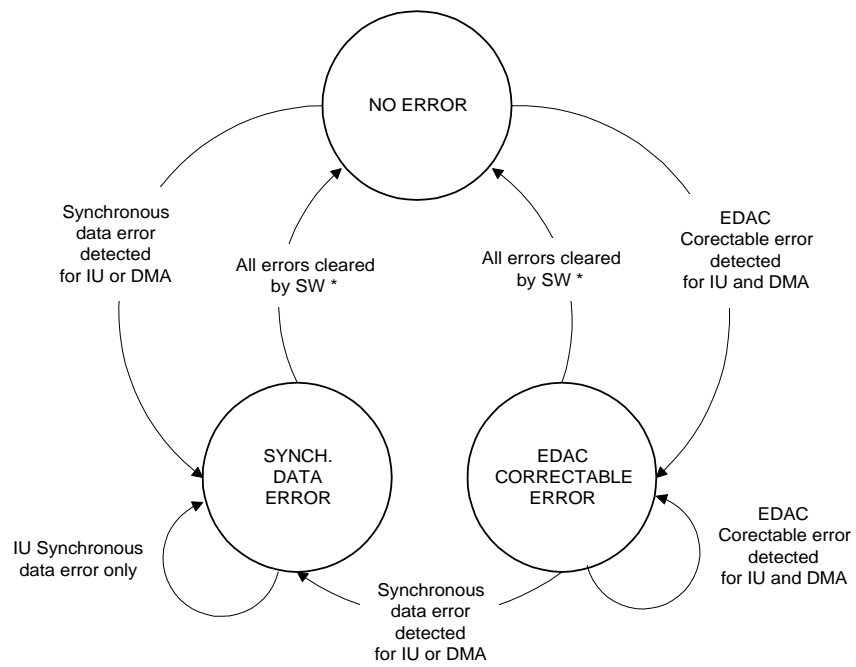

Each transition will update the SFSR and FAR registers
* FAR will keep its old value

Figure 12 - Error Handler Modes

The following tables show when updating of the registers is made.

Synchronous trap events	SFSR	FAR
Control bus parity error	U	U
Address bus parity error	U	U
Data bus parity error	U	U
Memory access protection error	U	U
Unimplemented address violation	U	U
MEC register violation error	U	U
EDAC uncorrectable error	U	U
Bus time-out	U	U
System bus error	U	U

Asynchronous trap events	SFSR	ERSR	FAR
Watchdog timeout *	U	U	
Ext. interrupt 4			
Real time clock interrupt			
General purpose timer interrupt			
Ext. interrupt 3			
Ext. interrupt 2			
DMA session timeout	U		
DMA access error	U		U
UART error interrupt	U		
EDAC correctable error	U		U
UART B data received or transmitter ready interrupt			
UART A data received or transmitter ready interrupt			
Ext. interrupt 1			
Ext. interrupt 0			
Masked hardware error interrupt		U	

U : register updated, parity updated

SFSR : System Fault Status register

ERSR : Error and Reset Status Register

FAR : Failing Address Register

* SFSR is updated at the time of Watchdog interrupt while ERSR is only updated if the Watchdog elapsed causes a halt or reset.

3.18. System Availability

The SYSAV bit in the **Error and Reset Status Register** (see page 61) can be used by software to indicate system availability. The SYSAV bit is cleared by reset and is programmable by software. Note that the SYSAV output of the MEC will be asserted only if the SYSAV bit is set *and* SYSERR* is deasserted, i.e. no error has been detected.

3.19. Test mode and Test Access Port

The MEC includes a number of test facilities such as EDAC test, Parity test, Interrupt test, Error test and a simple Test Access Port. These test functions are controlled using the **Test Control Register** (TCR) (see page 61).

3.19.1. EDAC Test

The EDAC function allows fault injection for memory test purposes and also test of the EDAC function itself. By enabling EDAC test mode in TCR (ET=1), the bits in the CB field of TCR will substitute the normal checkbits during store cycles.

3.19.2. Parity Test

The MEC register parity function allows fault injection for parity test purposes. By enabling parity test mode in TCR (PT=1), wrong parity will be generated when any MEC register is read.

3.19.3. Interrupt Test

It is possible to test and force interrupts by setting the corresponding bit in the **Interrupt Force Register** (page 57). Clearing of interrupts by setting the corresponding bit in the **Interrupt Clear Register** (ICR) will always clear the corresponding bit(s) in the **Interrupt Pending Register** (IPR), but will never affect the interrupts set in the **Interrupt Force Register** (IFR). However, it is possible to remove these interrupts by clearing the corresponding bit in IFR.

If the MEC is in interrupt test mode the handling of IFR and IPR is different:

When "Interrupt test" is not enabled:

- Setting or clearing a bit in IFR will only affect IFR. The corresponding interrupt will not be forced.
- When the interrupt is acknowledged, the MEC will automatically clear the bit in the IPR corresponding to the trap address as described above.

When "Interrupt test" is enabled:

- Setting a bit in IFR will force the corresponding interrupt if it is not masked in IMR.

- When the interrupt is acknowledged, the MEC will automatically clear the corresponding bit in the IFR if this bit is set, otherwise it will clear the corresponding bit in the IPR. In this way no external interrupts are lost.

Interrupt test mode is enabled in the **Test Control Register** (see page 61).

3.19.4. Error Test

The MEC error detection and handling allows fault injection for test purpose. By enabling Error test mode in TCR (EWE=1), an error could be simulated by writing to the Error and Reset Status Register, bits 5-0.

3.19.5. Test Access Port (TAP)

The MEC includes a Test Access Port (TAP) interface (IEEE standard 1149.1) for debugging and test purposes. The TAP does however not implement any scan function in the present version of the MEC, and only implements the Bypass register.

The timing of the TAP signals is according to IEEE 1149.1. This means that TDI and TMS are sampled by the ERC32 devices on the rising edge of TCK, and that TDO is driven on the falling edge .

Figure 12 - removed

3.20. System Clock

The MEC provides a system clock signal (SYSCLK) with a nominal 50 % duty cycle for the IU/FPU and the rest of the system.

The system clock is obtained by dividing an external clock signal (CLK2) by two. Please note that the MEC itself uses both SYSCLK and CLK2 directly. Some MEC output signals are clocked by the CLK2 negative edge which means that the CLK2 duty cycle has a direct impact on the system performance.

When interfacing peripherals (I/O interface, DMA interface etc.) it is highly recommended that only SYSCLK rising edge is used as reference as far as possible. CLK2 should be used as input to the MEC only.

3.21. MEC Registers

The writeable registers of the MEC are only writeable in the supervisor mode or in DMA mode during CPUHalt*. All registers except the UART RX and TX are readable in every access mode. The UART RX and TX registers are only readable in supervisor mode or in DMA mode during CPUHalt*. Read/write byte, halfword are not allowed in any mode and will generate Memory Exception, MEXC*.

3.21.1. Register Address Map

MEC Register	Address (hex)
MEC Control Register	01F8 0000
Software Reset Register	01F8 0004
Power Down Register	01F8 0008
Unimplemented area	01F8 000C
Memory Configuration Register	01F8 0010
I/O Configuration Register	01F8 0014
Waitstate Configuration Register	01F8 0018
Unimplemented area	01F8 001C
Access Protection Segment 1 Base Register	01F8 0020
Access Protection Segment 1 End Register	01F8 0024
Access Protection Segment 2 Base Register	01F8 0028
Access Protection Segment 2 End Register	01F8 002C
Unimplemented area	01F8 0030 - 01F8 0040
Interrupt Shape Register	01F8 0044
Interrupt Pending Register	01F8 0048
Interrupt Mask Register	01F8 004C
Interrupt Clear Register	01F8 0050
Interrupt Force Register	01F8 0054
Unimplemented area	01F8 0058 - 01F8 005C
Watchdog Program and Timeout Acknowledge Register	01F8 0060
Watchdog Trap Door Set	01F8 0064
Unimplemented area	01F8 0068 - 01F8 007C
Real Time Clock Timer <Counter>	01F8 0080
Real Time Clock Program Register <Counter>	01F8 0080
Real Time Clock <Scaler>	01F8 0084
Real Time Clock Program Register <Scaler>	01F8 0084
General Purpose Timer <Counter>	01F8 0088
General Purpose Timer Program Register <Counter>	01F8 0088
General Purpose Timer <Scaler>	01F8 008C
General Purpose Timer Program Register <Scaler>	01F8 008C
Unimplemented area	01F8 0090 - 01F8 0094
Timer Control Register	01F8 0098
Unimplemented area	01F8 009C
System Fault Status Register	01F8 00A0
Failing Address Register	01F8 00A4
Unimplemented area	01F8 00A8 - 01F8 00AC
Error and Reset Status Register	01F8 00B0
Unimplemented area	01F8 00B4 - 01F8 00CC
Test Control Register	01F8 00D0
Unimplemented area	01F800D4 - 01F800DC
UART Channel A RX and TX Register	01F8 00E0
UART Channel B RX and TX Register	01F8 00E4
UART Status Register	01F8 00E8
Unimplemented area	01F8 00EC - 01FF FFFF

3.21.2. Register Configuration and Bit Allocation

For each register the following information is given:

- **Address** of the register
- **Bits** is the bit allocation of the register. A bit can either have a unique function or a number of bits can be grouped together into a specific field.
- **Name** is the abbreviation for each bit or field.
- **Reset value** states the value for each bit or field to be obtained after the assertion of system reset.
- **Function** explains the function and use of each bit or field.
- **r/w** explains if the bit or field can be read and/or written.

Note that in some cases only part of the 32-bit register is used. The non usable bits are marked as **reserved** and will always have a fix value (generally zero) when being read and can thus not be altered by a write operation.

NOTE !! All reserved bits have to be written with zeros in order to avoid parity error resulting in a MEC internal error.

Certain registers below are not true registers in the sense that they only correspond to a write operation with any data. Any data may be used when writing to these registers. Nevertheless, they are part of the register memory map and therefore included.

MEC Control Register

01F8 0000 H

Bits	Name	Reset value	Function	r/w
0	PRD	0	Power-down 1 : enabled (allowed) 0 : disabled	r/w
1	SWR	0	Software reset 1 : enabled (allowed) 0 : disabled	r/w
2	BTO	1	Bus timeout 1 : enabled 0 : disabled	r/w
3	BP	0	Block protection instead of normal access protection 1 : enabled 0 : disabled	r/w
4	WDCS	1	Watchdog clock supply 1 : external clock with prescaler (divide by 16) 0 : external clock, no prescaler	r/w
5	IUEMMSK	0	IU Error Mode Mask 1 : Error masked (= disabled) 0 : Error not masked	r/w
6	RHIUEM	0	Reset or Halt when IU error mode (ERROR*) 1 : Reset 0 : Halt	r/w
7	IUHEMSK	0	IU Hardware Error Mask 1 : Error masked (= disabled) 0 : Error not masked	r/w
8	RHIUHE	0	Reset or Halt when IU Hardware Error (HWERR*) 1 : Reset 0 : Halt	r/w
9	IUCMPMSK	0	IU Comparison Error Mask 1 : Error masked (= disabled) 0 : Error not masked	r/w
10	RHIUCMP	0	Reset or Halt when IU comparison error 1 : Reset 0 : Halt	r/w
11	FPUCMPMSK	0	FPU Comparison Error Mask 1 : Error masked (= disabled) 0 : Error not masked	r/w
12	RHFPUAMP	0	Reset or Halt when FPU comparison error 1 : Reset 0 : Halt	r/w
13	MECHEMSK	0	MEC HW Error Mask 1 : Error masked (= disabled) 0 : Error not masked	r/w
14	RHMECHE	0	Reset or Halt when MEC HW Error (MECHWERR) 1 : Reset 0 : Halt	r/w
15	reserved	0	Not used	r
16	DMAE	1	DMA 1 : enabled 0 : disabled	r/w
17	DPE	0	DMA Parity Enabled 1 : enabled 0 : disabled	r/w
18	DST	1	DMA session timeout 1 : enabled 0 : disabled	r/w
19	UBR	0	UART baud rate(1) 1 : No change of UART scaler baudrate 0 : Divide UART scaler baudrate by two	r/w
20	UPE	1	UART parity enable 1 : parity enabled 0 : no parity	r/w
21	UP	1	UART parity 1 : odd parity 0 : even parity	r/w
22	USB	0	UART stop bits 1 : two stop bits 0 : one stop bit	r/w
23	UCS	1	UART clock supply 1 : system clock 0 : external clock	r/w
31-24	Scaler	00000001	UART scaler, (1) 1 - 255: Divide factor 0: stops the UART clock	r/w

- 1) The scaler shall be set to: $Scaler = \frac{Clock}{32 * Baudrate * (2 - UBR) - 1}$
 Where **Clock** is either the frequency of the system clock (SYSCLK) or the watchdog clock (WDCLK) selected by UCS (bit 23 in MEC Control Register). **UBR** is the value of the UBR bit. **Baudrate** is the desired baudrate. Note that the resulting actual baudrate will probably not be exactly the desired one. This is due to the fact that **Scaler** is an integer number, and the above given equation may yield a non-integer result, depending on the **Clock** frequency.

Software Reset Register **01F8 0004 H**

Write only with any data. A write to this register will cause the MEC to issue the RESET* signal if the software reset function is enabled in the MEC Control register. If the software reset function is not enabled, a write to this register will have no effect.

Power Down Register **01F8 0008 H**

Write only with any data. A write to this register will cause the system to enter power down mode (see paragraph 3.5.4.) if the power down function is enabled in the MEC Control Register. If the power down function is not enabled, a write to this register will have no effect.

Memory Configuration Register **01F8 0010 H**

Bits	Name	Reset value	Function	r/w
1-0	RBCS	00	Number of RAM blocks (chip selects used) 00 : MEMCS<0> active 01 : MEMCS<1:0> active 10 : MEMCS<3:0> active 11 : MEMCS<7:0> active	r/w
2	RBS0	0	Redundant RAM block0 selected. 0 : not selected 1 : selected	r/w
5-3	RBR0	000	Redundant RAM block0 can replace any of the RAM blocks. The MEMCS corresponding to the replaced block will be inactive and MEMCS<8> will be active instead. 000 : MEMCS<0> inactive and replaced 001 : MEMCS<1> inactive and replaced 010 : MEMCS<2> inactive and replaced 011 : MEMCS<3> inactive and replaced 100 : MEMCS<4> inactive and replaced 101 : MEMCS<5> inactive and replaced 110 : MEMCS<6> inactive and replaced 111 : MEMCS<7> inactive and replaced	r/w
6	RBS1	0	Redundant RAM block1 selected. 0 : not selected 1 : selected	r/w
9-7	RBR1 (1)	000	Redundant RAM block1 can replace any of the RAM blocks. The MEMCS corresponding to the replaced block will be inactive and MEMCS<9> will be active instead. 000 : MEMCS<0> inactive and replaced 001 : MEMCS<1> inactive and replaced 010 : MEMCS<2> inactive and replaced 011 : MEMCS<3> inactive and replaced 100 : MEMCS<4> inactive and replaced 101 : MEMCS<5> inactive and replaced 110 : MEMCS<6> inactive and replaced 111 : MEMCS<7> inactive and replaced	r/w
12-10	RSIZ	000	RAM size 000 : 256 Kbyte 001 : 512 Kbyte 010 : 1 Mbyte 011 : 2 Mbyte 100 : 4 Mbyte 101 : 8 Mbyte 110 : 16 Mbyte 111 : 32 Mbyte	r/w
13	RPA (3)	0	RAM memory parity protected 1 : enabled 0 : disabled	r/w
14	REC	0	RAM EDAC protected 1 : enabled 0 : disabled (Note: When EDAC is enabled parity is enabled independent of RPA)	r/w
15	Reserved	0	Not used	r
16	PWR	1	PROM write function 1 : enabled if external ROMWRT* present 0 : disabled	r/w

17	P8 (2)	*	PROM 8-bit wide 1 : 40-bit wide, EDAC and Parity 0 : 8-bit wide, Parity generation	r
20-18	PSIZ	000	PROM size 000 : 128 Kbyte 001 : 256 Kbyte 010 : 512 Kbyte 011 : 1 Mbyte 100 : 2 Mbyte 101 : 4 Mbyte 110 : 8 Mbyte 111 : 16 Mbyte	r/w
23-21	Reserved	000	Not used	r
26-24	ESIZ	000	Exchange memory size 000 : 4 Kbyte 001 : 8 Kbyte 010 : 16 Kbyte 011 : 32 Kbyte 100 : 64 Kbyte 101 : 128 Kbyte 110 : 256 Kbyte 111 : 512 Kbyte	r/w
27	EPA (3)	0	Exchange memory parity protected 1 : enabled 0 : disabled	r/w
28	EEC	0	Exchange memory EDAC protected 1 : enabled 0 : disabled (Note: When EDAC is enabled parity is enabled independent of EPA)	r/w
29	EEX	0	Exchange memory exists 1 : exists 0 : exists not	r/w
31-30	Reserved	00	Not used	r

- 1) If RBR0 and RBR1 are set to the same value, RBR1 settings will have no effect.
- 2) Is at reset automatically written with same value as PROM8 input pin to MEC. A write operation to this bit has no effect (is don't care).
- 3) If the NOPAR* signal is asserted, data parity is not checked even if enabled in this register.

I/O Configuration Register

01F8 0014 H

Bits	Name	Reset value	Function	r/w
3-0	SIZ0	0000	I/O unit<0> size. 0000 : 512 bytes 0001 : 1 Kbytes 0010 : 2 Kbytes 0011 : 4 Kbytes 0100 : 8 Kbytes 0101 : 16 Kbytes 0110 : 32 Kbytes 0111 : 64 Kbytes 1000 : 128 Kbytes 1001 : 256 Kbytes 1010 : 512 Kbytes 1011 : 1 Mbytes 1100 : 2 Mbytes 1101 : 4 Mbytes 1110 : 8 Mbytes 1111 : 16 Mbytes	r/w
4	IO0	0	I/O unit <0> enabled1 : enable 0 : disabled	r/w
5	PA0	0	Parity supplied by I/O unit <0> 1 : Yes (Note: MEC checks parity) 0 : No (Note: MEC generated parity)	r/w
6	Reserved	0	Not used	r
7	Reserved	0	Not used	r
11-8	SIZ1	0000	I/O unit<1> size. Coded as for I/O unit<0>	r/w
12	IO1	0	I/O unit<1> enabled 1 : enabled 0 : disabled	r/w
13	PA1	0	Parity supplied by I/O unit <1> 1 : Yes (Note: MEC checks parity) 0 : No (Note: MEC generated parity)	r/w
14	Reserved	0	Not used	r
15	Reserved	0	Not used	r
19-16	SIZ2	0000	I/O unit<2> size. Coded as I/O unit<0>	r/w
20	IO2	0	I/O unit<2> enabled 1 : enabled 0 : disabled	r/w
21	PA2	0	Parity supplied by I/O unit <2> 1 : Yes (Note: MEC checks parity) 0 : No (Note: MEC generated parity)	r/w
22	Reserved	0	Not used	r
23	Reserved	0	Not used	r
27-24	SIZ3	0000	I/O unit<3> size. Coded as I/O unit<0>	r/w
28	IO3	0	I/O unit<3> enabled 1 : enabled 0 : disabled	r/w
29	PA3	0	Parity supplied by I/O unit <3> 1 : Yes (Note: MEC checks parity) 0 : No (Note: MEC generated parity)	r/w
30	Reserved	0	Not used	r
31	Reserved	0	Not used	r

Waitstate Configuration Register 01F8 0018 H

Bits	Name	Reset value	Function	r/w
1-0	RAR	11	RAM read, no. of waitstates. 00 : 0 WS 01 : 1 WS 10 : 2 WS 11 : 3 WS	w
3-2	RAW	11	RAM write, no of waitstates. 00 : 0 WS 01 : 1 WS 10 : 2 WS 11 : 3 WS	w
7-4	PRR	1111	PROM read, no. of waitstates. 0000 : 0 WS 0001 : 0 WS 0010 : 1 WS .. 1111 : 14 WS	w
11-8	PRW	1111	PROM write, no. of waitstates. 0000 : 0 WS 0001 : 0 WS 0010 : 1 WS .. 1111 : 15 WS	
15-12	EXRW	1111	Exchange memory read/write, no. of waitstates. 0000 : 0 WS 0001 : 0 WS 0010 : 1 WS .. 1111 : 15 WS	w
19-16	IO0RW	1111	IO 0 read/write, no. of waitstates. 0000 : "0 WS" See Note 1 below 0001 : 0 WS 0010 : 1 WS .. 1111 : 14 WS	w
23-20	IO1RW	1111	IO 1 read/write, no. of waitstates. 0000 : "0 WS" See Note 1 below 0001 : 0 WS 0010 : 1 WS .. 1111 : 14 WS	w
27-24	IO2RW	1111	IO 2 read/write, no. of waitstates. 0000 : "0 WS" See Note 1 below 0001 : 0 WS 0010 : 1 WS .. 1111 : 14 WS	w
31-28	IO3RW	1111	IO 3 read/write, no. of waitstates. 0000 : "0 WS" See Note 1 below 0001 : 0 WS 0010 : 1 WS .. 1111 : 14 WS	w

Note 1) In the I/O area the MEC will always insert one waitstate to wait for the BUSRDY* signal, even when "0 WS" is programmed in the above register.

Access Protection Segment 1 Base Register 01F8 0020 H

Access Protection Segment 2 Base Register 01F8 0028 H

Bits	Name	Reset value	Function	r/w
22-0	SEGBASE	0	Segment start address. The base address for the segment is calculated according to the formula $BASEADDR = 0x02000000 + SEGBASE * 4$	r/w
23	UE	0	0 = access protection disabled in user mode 1 = access protection enabled in user mode	r/w
24	SE	0	0 = access protection disabled in supervisor mode 1 = access protection enabled in supervisor mode	r/w
31-25		0	Not used	r/w

Note) The Access Protection is enable only for data write cycles.

Access Protection Segment 1 End Register 01F8 0024 H

Access Protection Segment 2 End Register 01F8 002C H

Bits	Name	Reset value	Function	r/w
22-0	SEGEND	0x000000	Segment end address denoting the first address outside the segment. The end address for the segment is calculated according to the formula $ENDADDR = 0x02000000 + SEGEND * 4$	r/w
31-23		0	Not used	r/w

Interrupt Shape Register 01F8 0044 H

Bits	Name	Reset value	Function	r/w
4-0	EDGE	00000	External interrupts edge or level triggered xxxx1 : external interrupt 0 edge triggered xxxx0 : external interrupt 0 level triggered xxx1x : external interrupt 1 edge triggered xxx0x : external interrupt 1 level triggered .. 1xxxx : external interrupt 4 edge triggered 0xxxx : external interrupt 4 level triggered	r/w
7-5	ACK	000	Acknowledge on external interrupt. 000 : No action 001 : external interrupt 0 acknowledged 010 : external interrupt 1 acknowledged 011 : external interrupt 2 acknowledged 100 : external interrupt 3 acknowledged 101 : external interrupt 4 acknowledged 110 : No action 111 : No action	r/w
12-8	POL	00000	External interrupts polarity xxxx1 : external interrupt 0 active high xxxx0 : external interrupt 0 active low xxx1x : external interrupt 1 active high xxx0x : external interrupt 1 active low .. 1xxxx : external interrupt 4 active high 0xxxx : external interrupt 4 active low	r/w
31-13	Reserved	0h	Not used	r

Interrupt Pending Register 01F8 0048 H

Bits	Name	Reset value	Function	r/w
0	Reserved	0	Not used	r
15-1	IP	0h	Pending interrupts bit 1 = 1 : interrupt 1 pending bit 1 = 0 : interrupt 1 not pending .. bit 15 = 1 : interrupt 15 pending bit 15 = 0 : interrupt 15 not pending	r
31-16	Reserved	0h	Not used	r

Interrupt Mask Register

01F8 004C H

Bits	Name	Reset value	Function	r/w
0	Reserved	0	Not used	r
14-1	IM	3FFFh	Masked interrupts bit 1 = 1 : interrupt 1 masked bit 1 = 0 : interrupt 1 not masked .. bit 14 = 1 : interrupt 14 masked bit 14 = 0 : interrupt 14 not masked	r/w
31-15	Reserved	0h	Not used	r

Interrupt Clear Register

01F8 0050 H

Bits	Name	Reset value	Function	r/w
0	Reserved	0	Not used	-
15-1	IC	0h	Cleared interrupts bit 1 = 1 : interrupt 1 cleared bit 1 = 0 : interrupt 1 not cleared .. bit 15 = 1 : interrupt 15 cleared bit 15 = 0 : interrupt 15 not cleared	w
31-16	Reserved	0h	Not used	-

Interrupt Force Register

01F8 0054 H

Bits	Name	Reset value	Function	r/w
0	Reserved	0	Not used	r
15-1	IF	0h	Forced interrupts bit 1 = 1 : interrupt 1 forced bit 1 = 0 : interrupt 1 not forced .. bit 15 = 1 : interrupt 15 forced bit 15 = 0 : interrupt 15 not forced	r/w
31-16	Reserved	0h	Not used	r

Watchdog Program and Timeout Acknowledge Register 01F8 0060 H

Bits	Name	Reset value	Function	r/w
15-0	WDC	FFFFh	Preset 16-bit counter value	w
23-16	WDS	FFh	Preset 8-bit scaler value	w
31-24	WDR	FFh	Preset 8-bit reset counter value	w

The timeout for the watchdog before the watchdog interrupt occurs is calculated as:

$$\text{Timeout} = (16^{\text{WDCS}} \cdot (\text{WDS} + 1) \cdot (\text{WDC} + 1)) / \text{WDCLK}$$

The timeout for the watchdog before warm reset occurs is calculated as:

$$\text{Reset timeout} = \text{Timeout} + 16^{\text{WDCS}} \cdot (\text{WDS} + 1) \cdot (\text{WDR} + 1) / \text{WDCLK}$$

Where WDCS is the Watchdog Clock Supply bit of the MEC Control Register and WDCLK is the frequency of the WDCLK input signal.

Watchdog Trap Door Set

01F8 0064 H

Write only with any data. A write to this register after reset but before the watchdog has elapsed will disable the watchdog. The watchdog will stay disabled until it is reprogrammed by writing to the Watchdog Program and Timeout Acknowledge Register.

Real Time Clock Timer <Counter> 01F8 0080 H

Bits	Name	Reset value	Function	r/w
31-0	RTCC	FFFFFFFFh	Down counting 32-bit counter	r

Real Time Clock Program Register <Counter> 01F8 0080 H

Bits	Name	Reset value	Function	r/w
31-0	RTCC	FFFFFFFFh	Programmed 32-bit counter value	w

Real Time Clock <Scaler> 01F8 0084 H

Bits	Name	Reset value	Function	r/w
7-0	RTCS	FFh	Down counting 8-bit scaler	r
31-8	Reserved	0h	Not used	-

Real Time Clock Program Register <Scaler> 01F8 0084 H

Bits	Name	Reset value	Function	r/w
7-0	RTCS	FFh	Programmed 8-bit scaler value	w
31-8	Reserved	0h	Not used	-

The timeout for the real time clock before the interrupt occurs is calculated as:

$$\text{Timeout} = (\text{RTCC}) \cdot (\text{RTCS} + 1) / \text{SYSCLK}$$

where SYSCLK is the system clock frequency.

General Purpose Timer <Counter> 01F8 0088 H

Bits	Name	Reset value	Function	r/w
31-0	GPTC	FFFFFFFFh	Down counting 32-bit counter	r

General Purpose Timer Program Register <Counter> 01F8 0088 H

Bits	Name	Reset value	Function	r/w
31-0	GPTC	FFFFFFFFh	Programmed 32-bit counter value	w

General Purpose Timer <Scaler> 01F8 008C H

Bits	Name	Reset value	Function	r/w
15-0	GPTS	FFFFh	Down counting 16-bit scaler	r
31-16	Reserved	0h	Not used	-

General Purpose Timer Program Register <Scaler>

01F8 008C H

Bits	Name	Reset value	Function	r/w
15-0	GPTS	FFFFh	Programmed 16-bit scaler value	w
31-16	Reserved	0h	Not used	-

The timeout for the general purpose timer before the interrupt occurs is calculated as:

$$\text{Timeout} = ((\text{GPTC}) \cdot (\text{GPTS} + 1)) / \text{SYSCLK}$$

where SYSCLK is the system clock frequency.

Timer Control Register

01F8 0098 H

Bits	Name	Reset value	Function	r/w
0	GCR	0	General Purpose Timer Counter Reload 1 : reload counter at zero and restart 0 : stop counter at zero	w
1	GCL	0	General Purpose Timer counter load 1 : load counter with preset value and start if enabled 0 : no function	w
2	GSE	0	General Purpose Timer enable 1 : enable counting 0 : hold scaler (and counter)	w
3	GSL	0	General Purpose Timer Scaler load 1 : load scaler with preset value and start if enabled 0 : no function	w
4	Reserved	0	Not used	r
5	Reserved	0	Not used	r
6	Reserved	0	Not used	r
7	Reserved	0	Not used	r
8	RTCCR	1	Real Time Clock Counter Reload 1 : reload counter at zero and restart 0 : stop counter at zero	w
9	RTCCL	0	Real Time Clock counter load 1 : load counter with preset value and start if enabled 0 : no function	w
10	RTCSE	0	Real Time Clock Scaler enable 1 : enable counting 0 : hold scaler (and counter)	w
11	RTCSL	0	Real Time Clock Scaler load 1 : load scaler with preset value and start if enabled 0 : no function	w
31-12	Reserved	0h	Not used	-

System Fault Status Register

01F8 00A0 H

Bits	Name	Reset value	Function	r/w
1-0	Reserved	00	Not used	r
2	SDFV	0	IU data fault valid 1 : valid 0 : not valid	r/w
6-3	SRFT	1111	Data fault type or DMA error type 0000 : Parity error on control bus 0001 : Parity error on data bus 0010 : Parity error on address bus 0011 : Access to protected area 0100 : Access to unimplemented area 0101 : MEC register parity error 0110 : MEC register access violation 0111 : Uncorrectable error in memory 1000 : Bus time-out 1001 : System bus error 1010 to 1110 : Not used 1111 : Reset value	r/w
7	Reserved	0	Not used	r
8	ASFV	0	Asynchronous fault valid 1 : valid 0 : not valid	r/w
10-9	ASFT	00	Asynchronous fault type 00 : Watch Dog time-out 01 : DMA time-out/access error 10 : UART error 11 : Correctable error in memory	r/w
11	Reserved	0	Not used	r
15-12	AT	0000	Access type see table below	r/w
31-16	Reserved	0h	Not used	r

Note 1 If this register is written the data is irrelevant. The register is set to the value 00000078 hex.

Note 2 DMA errors will not overwrite the System Fault Status Register if IU data fault valid bit is set.

Note 3 The information about ASFT can be extracted by SW from the IPR as well.

Access type

AT	Access Type	Access Mode	ASI
0000	Load	User Data RAM/ROM/Register	0xA
0001	Load	Supervisor Data RAM/ROM/Register	0xB
0010	-	Not used	-
0011	-	Not used	-
0100	Load	DMA RAM/ROM/Register	Do not care
0101	Load/execute	User I/O/Exchange	0xA, 0x8
0110	Load/execute	Supervisor I/O/Exchange	0xB, 0x9
0111	Load	DMA I/O/Exchange	Do not care
1000	Store	User Data RAM/ROM/Register	0xA
1001	Store	Supervisor Data RAM/ROM/Register	0xB
1010	-	Not used	-
1011	-	Not used	-
1100	Store	DMA RAM/ROM/Register	Do not care
1101	Store	User I/O/Exchange	0xA, 0x8
1110	Store	Supervisor I/O/Exchange	0xB, 0x9
1111	Store	DMA I/O/Exchange	Do not care

Note: Accesses in the "Extended general area" are treated as RAM Accesses from an Access Type point of view.

Failing Address Register 01F8 00A4 H

Bits	Name	Reset value	Function	r/w
31-0	FFA	0h	Failing address	r

Error and Reset Status Register 01F8 00B0 H

Bits	Name	Reset value	Function	r/w
0	IUEM	0	IU error mode 1 : error 0 : no error	r/w
1	IUHE	0	IU hardware error 1 : error 0 : no error	r/w
2	IUCMP	0	IU comparison error 1 : error 0 : no error	r/w
3	FPUHE	0	FPU hardware error (no MEC action) 1 : error 0 : no error	r/w
4	FPUCMP	0	FPU comparison error 1 : error 0 : no error	r/w
5	MECHE	0	MEC hardware error. 1 : Internal parity error 0 : no error	r/w
11 - 6		0	Not used	r/w
12	SYSAV	0	ERC32 System availability 1 : System available 0 : System not available	r/w
13	HLT	0	IU/FPU halted 1 : active 0 : not active	r
15-14	RSTC	xx	Reset cause. 00 : system reset 01 : software reset 10 : error reset 11 : watchdog reset	r
31-16	Reserved	0h	Not used	r

Note: Bit 5-0 are only writeable when the EWE bit in the Test Control Register is set

Test Control Register 01F8 00D0 H

Bits	Name	Reset value	Function	r/w
6-0	CB	0	Check bits	r/w
16-7		0	Not used	r
17	ET	0	EDAC test enable 0: Testing disabled 1: Memory test enabled	r/w
18	PT	0	Parity test 1 : test enabled 0 : test disabled	r/w
19	IT	0	Interrupt Force Register Write Enable 1 : enabled 0 : disabled	r/w
20	EWE	0	Error Write Enable 1: Write to Error and Reset Status Register enabled 0: Write to Error and Reset Status Register disabled	r/w
31-21		0	Not used	r

UART Channel A RX and TX Register

01F8 00E0 H

Bits	Name	Reset value	Function	r/w
7-0	RTD	0h	Rx/Tx data	r/w
31-8	Reserved	0h	not used	r

UART Channel B RX and TX Register

01F8 00E4 H

Bits	Name	Reset value	Function	r/w
7-0	RTD	0h	Rx/Tx data	r/w
31-8	Reserved	0h	not used	r

UART Status Register

01F8 00E8 H

Bits	Name	Reset value	Function	r/w
0	DRA	0	Data Ready in channel A	r
1	TSEA	1	Transmitter A Send Register Empty (no data to send)	r
2	THEA	1	Transmitter A Holding register Empty (ready to load data)	r
3	Reserved	0	Not used	r
4	FEA	0	Framing Error in receiver A	r
5	PEA	0	Parity Error in receiver A	r
6	OEA	0	Overrun Error in receiver A	r
7	CUA	0	Clear UART A (bit read as zero)	r/w
15-8	Reserved	0h	Not used	r
16	DRB	0	Data Ready in channel B	r
17	TSEB	1	Transmitter B Send Register Empty (no data to send)	r
18	THEB	1	Transmitter B Holding register Empty (ready to load data)	r
19	Reserved	0	Not used	r
20	FEB	0	Framing Error in receiver B	r
21	PEB	0	Parity Error in receiver B	r
22	OEB	0	Overrun Error in receiver B	r
23	CUB	0	Clear UART B (bit read as zero)	r/w
31-24	Reserved	0h	not used	r

4. MEMORY CONTROLLER SIGNAL DESCRIPTIONS

4.1. Memory Controller Signal Summary

Table 6 lists the MEC signals. They are listed according to the signal name; the number of pins allocated; the input (I), output(O) operating modes; a signal description; if it is protected by parity (P); and the classification and grouping related to electrical characteristics.

An asterisk *, after the signal name indicates that the signal is active low (true at a logic 0 level).

Table 6 - MEC Signal Summary

Signal	#Pins	I/O/Z	Description	Par	Pin Type
<i>IU/FPU Interface Signals</i>					
A[31:0]	32	I	Address Bus	P	TTL
APAR	1	I	Address Bus Parity	P	TTL
ASI[3:0]	4	I	Address Space Identifier	P	TTL
SIZE[1:0]	2	I	Bus Transaction Size	P	TTL
ASPAR	1	I	ASI and SIZE Parity	P	TTL
D[31:0]	32	I/O	Data Bus	P	TTL/CMOS
DPARIO	1	I/O	Data Bus Parity Input/Output	P	TTL/CMOS
DMAAS	1	I	DMA Address Strobe		TTL
DRDY*	1	O	Data Ready during DMA access		TTL
EXTHOLD*	1	I	External Hold Input (FHOLD*)		TTL
EXTCCV	1	I	External CCV Input (FCCV)		TTL
INULL	1	I	Integer Unit Nullify Cycle		TTL
DXFER	1	I	Data Transfer	P	TTL
LDSTO	1	I	Atomic Load-Store	P	TTL
LOCK	1	I	Bus Lock	P	TTL
RD	1	I	Read Access	P	TTL
WE*	1	I	Write Enable	P	TTL
WRT	1	I	Advanced Write	P	TTL
IMPAR	1	I	IU to MEC Control Parity	P	TTL
AOE*	1	O	Address Output Enable		CMOS
COE*	1	O	Control Output Enable		CMOS
DOE*	1	O	Data Output Enable		CMOS
BHOLD*	1	O	Bus Hold		CMOS
MDS*	1	O	Memory Data Strobe		CMOS
MEXC*	1	O	Memory Exception		CMOS

MHOLD*	1	O	Memory Bus Hold	CMOS
<i>Memory System Interface Signals</i>				
BA[1:0]	2	O	Latched Address used for 8-bit Wide Boot PROM	CMOS
CB[6:0]	7	I/O	Check Bits	TTL/CMOS
ALE*	1	O	Address Latch Enable	CMOS
PROM8*	1	I	Select 8-bit Wide PROM	TTL
ROMCS*	1	O	PROM Chip Select	CMOS
MEMCS*[9:0]	10	O	Memory Chip Select	CMOS
OE*[1:0]	2	O	Output Enable	CMOS
MEMWR1*[1:0]	2	O	Memory Write Strobe	CMOS
MEMWR2*[1:0]	2	O	Check Bit Memory Write Strobe	CMOS
RAMBEN*	1	O	RAM Buffer Enable	CMOS
ROMBEN*	1	O	ROM Buffer Enable	CMOS
MEMBEN*	1	O	Memory Buffer Enable	CMOS
DDIR	1	O	Buffer Data Direction	CMOS
DDIR*	1	O	Buffer Data Direction	CMOS
IOSEL*[3:0]	4	O	IO Chip Select	CMOS
IOWR*	1	O	IO and Exchange Memory Write Strobe	CMOS
IOBEN*	1	O	IO and Exchange Mem.Buf.Enable	CMOS
EXMCS*	1	O	Exchange Memory Chip Select	CMOS
BUSRDY*	1	I	Bus Ready	TTL
BUSERR*	1	I	Bus Error	TTL
DMAREQ*	1	I	DMA Request	TTL
DMAGNT*	1	O	DMA Grant	CMOS
<i>Interrupt and Control Signals</i>				
IRL[3:0]	4	O	Interrupt Request Level	CMOS
INTACK	1	I	Interrupt Acknowledge	TTL
EXTINT[4:0]	5	I	External Interrupt	TTL
EXTINTACK	1	O	External Interrupt Acknowledge	CMOS
SYSRESET*	1	I	System Reset	SCH_TR
RESET*	1	O	Reset	CMOS
IUERR*	1	I	IU Error	TTL
IUHWERR*	1	I	IU Hardware Error	TTL
IUCMPERR*	1	I	IU Comparison Error	TTL
FPUHWERR*	1	I	FPU Hardware Error	TTL
FPUCMPERR*	1	I	FPU Comparison Error	TTL
MECHWERR*	1	O	MEC Hardware Error	CMOS
SYSERR*	1	O	System Error	CMOS
SYSAV	1	O	System Availability	CMOS
SYSHALT*	1	I	System Halt	TTL
NOPAR*	1	I	No Parity	TTL

ROMWRT*	1	I	ROM Write Enable		TTL
CPUHALT*	1	O	Processor (IU and FPU) Halt		CMOS
<i>Test Access Port Signals</i>					
TCK	1	I	Test Clock		TTL
TRST*	1	I	Test Reset		TTL
TMS	1	I	Test Mode Select		TTL
TDI	1	I	Test Data Input		TTL
TDO	1	O	Test Data Output		CMOS
<i>UART Interface</i>					
WDCLK	1	I	Watch Dog Clock		TTL
RXA	1	I	Receive Data channel		TTL
RXB	1	I	Receive Data channel B		TTL
TXA	1	O	Transmit Data channel A		CMOS
TXB	1	O	Transmit Data channel B		CMOS
<i>Power and Clock Signals</i>					
CLK2	1	I	Double Frequency Clock		TTL
SYSCLK[1:0]	2	O	System Clock		TTL/CMOS
VCCI	5	I	Main internal VCC		
VCCO	17	I	Output driver VCC		
VSSI	5	I	Main internal VSS		
VSSO	17	I	Output driver VSS		
Number of pins	218				

4.2. MEC Detailed Signal Descriptions

4.2.1. IU/FPU Interface Signals

A[31:0] - Address Bus (input)

The address bus for the MEC is an input-only bus. The MEC uses the address bus to perform decoding, to generate select signals, and to check against the memory access protection scheme. It is also used to address the MEC registers. In case of Direct Memory Access, DMA, the address bus is driven by the DMA unit.

APAR - Address Bus Parity (input)

This input is used by the MEC to check the odd parity over the 32-bit address bus. In case of Direct Memory Access, DMA, this signal must be driven by the DMA unit in case DMA parity is enabled.

ASI[3:0] - Address Space Identifier (input)

These four bits constitute the Address Space Identifier (ASI), which identifies the memory address space to which the memory access is being directed. The ASI bits are latched by the MEC and are used to detect supervisor mode, instruction or data access, etc. A DMA unit must supply these bits.

SIZE[1:0] - Bus Transaction Size (input)

The coding on these pins specifies for the MEC the size of the data being transferred during a memory access. A DMA unit must drive these bits to '10', since only word transfers are allowed in DMA mode.

ASPAR - ASI and SIZE Parity (input)

This input is used by the MEC to check the odd parity over the ASI[3:0] and the SIZE[1:0] signals. A DMA unit must supply this bit in case DMA parity is enabled. Note that although ASI[7:0] exist in the IU, only ASI[3:0] are connected to the MEC. This means that from the IU, only alternate address space accesses with ASI[7:4] containing 0, 2 or 4 ones may be used (ASI[7:4] = 0000, 0011, 0101, 0110, 1001, 1010, 1100 or 1111), otherwise an ASI and SIZE parity error will be detected in the MEC, as the IU computes ASPAR over the full ASI[7:0] range.

D[31:0] - Data Bus (bi-directional)

These pins form a 32-bit bi-directional data bus that serves as the interface between the IU and the MEC. It is driven by the MEC only during read of its internal registers, when reading the boot PROM in 8-bit mode, and when a single bit error is detected by the EDAC. When implementing a system with an 8-bit PROM, the PROM shall be connected to bits D[7:0]. In case of Direct Memory Access, DMA, it is driven or read by the DMA unit.

DPARIO - Data Bus Parity Input/Output (bi-directional)

This pin is used by the MEC to check and generate the odd parity over the 32-bit data bus during write cycles. A DMA unit must supply this bit in case DMA parity is enabled. See also Table 4 on page 32.

DMAAS - DMA Address Strobe (input)

During DMA transfers (when the external DMA is bus master) this input is used to inform the MEC that the address from the DMA is valid and that the access cycle shall start. DMAAS can be asserted multiple times during DMA grant.

DRDY* - Data Ready during DMA access (output)

During DMA read transfers (when the external DMA is bus master) this output is used to inform the DMA unit that the data are valid. During DMA write transfers this signal indicates that data have been written into memory.

INULL - Integer Unit Nullify Cycle (input)

INULL is output from the IU to indicate that the current memory access is nullified. See further the IU signal description.

ExtHOLD* - External unit Hold (input)

This signal input is used to synchronize coprocessor compare instructions with branch instructions. The MEC shall use this signal for prolonging of ongoing cycle. See further the FPU FHold / CHold signal description.

ExtCCV - External unit Condition Codes Valid (input)

This signal input is used to hold the MEC when a coprocessor can not continue execution. The MEC shall use this signal for prolonging of ongoing cycle. See further the FPU FCCV / CCCV signal description.

DXFER - Data Transfer (input)

DXFER is used to differentiate between the addresses being sent out for instruction fetches and the addresses of data fetches. DXFER is asserted by the processor during the address cycles of all bus data transfer cycles, including both cycles of store single and all three cycles of store double and atomic load-store. DXFER is sent out unlatched and is latched in the MEC before it is used. A DMA unit must supply this signal during a DMA session.

LDSTO - Atomic Load-Store (input)

This signal is used to identify an atomic load-store to the system and is asserted by the integer unit during all the data cycles (the load cycle and both store cycles) of atomic load-store instructions. LDSTO is sent out unlatched and is latched in the MEC before it is used. A DMA unit must supply this signal during a DMA session.

LOCK -Bus Lock (input)

LOCK is asserted by the processor when it needs to retain control of the bus (address and data) for multiple cycle transactions (Load Double, Store Single and Double, Atomic Load-Store). The bus will not be granted to another bus master as long as LOCK is asserted. Note that BHOLD* should not be asserted in the processor clock cycle which follows a cycle in which LOCK is asserted. LOCK is sent out unlatched and must be latched externally before it is used. A DMA unit must supply this signal during a DMA session.

RD - Read Access (input)

RD is used in conjunction with SIZE[1:0], ASI[3:0] and LDSTO to determine the type of transfer and to check the write access rights of bus transactions. It may also be used to turn off the output drivers of data RAMs during a store operation. A DMA unit must supply this signal during a DMA session, deasserted low for write and asserted high for read accesses.

WE* - Write Enable (input)

WE* is asserted by the integer unit during the cycle in which the store data is on the data bus. For a store single instruction, this is during the second store address cycle; the second and third store address cycles of store double instructions, and the third load-store address cycle of atomic load-store instructions. It is sent out unlatched and is latched in the MEC before it is used. To avoid writing to memory during memory exceptions, WE* is internally qualified by MHOLD* and MEXC*. A DMA unit must supply this signal during a DMA session, asserted low for write and deasserted high for read accesses.

WRT - Advanced Write (input)

WRT is an early write signal, asserted by the processor during the first store address cycle of integer single or double store instructions, the first store address cycle of floating-point single or double store instructions, and the second load-store address cycle of atomic load-store instructions. WRT is sent out unlatched and is latched in the MEC before it is used. A DMA unit must supply this signal during a DMA session, deasserted low for read and asserted high for write accesses.

IMPAR - IU to MEC Control Parity (input)

This input is used by the MEC to check the odd parity over the LDSTO, DXFER, LOCK, WRT, RD, and WE* signals. This signal must be driven by the DMA if DMA uses parity.

AOE* - Address Output Enable (output)

The MEC deasserts this signal when an external master (DMA unit) uses the address bus.

COE* - Control Output Enable (output)

The MEC deasserts this signal when an external master (DMA unit) uses the control bus.

DOE* - Data Output Enable (output)

The MEC deasserts this signal when an external master (DMA unit) uses the data bus.

BHOLD* - Bus Hold (output)

The MEC asserts this signal during DMA accesses.

MDS* - Memory Data Strobe (output)

During nominal execution with the IU as bus master, MDS* is asserted by the MEC to enable the clock to the instruction register of the IU (during an instruction fetch) or to the load result register (during a data fetch) while the pipeline is frozen with an MHOLDA/B*.

MEXC* - Memory Exception (output)

Assertion of this signal by the MEC initiates an instruction access exception or data access exception trap and indicates to the IU that the memory system was unable to supply a valid instruction or data. It is asserted when a parity error, uncorrectable EDAC error, access violation, bus time-out or system bus error is detected. If this signal is asserted during a DMA transfer, the DMA must withdraw its DMA request and end the DMA cycle.

MHOLD* - Memory Bus Hold (output)

MHOLD* is used to freeze the clock to both the IU and floating-point unit during a cache miss (for systems with cache memory) or when accessing a slow memory. It is generated by the MEC to insert wait states during memory or I/O accesses.

4.2.2. Memory System Interface Signals

BA[1:0] - Boot PROM Latched Address used for 8-bit Wide PROM (output)

These outputs are used when 8-bit wide PROM is connected to the MEC. During a read access to the PROM, the BA[1:0] will be asserted four times in order to get the four bytes needed to generate a 32-bit word. The MEC will assert the BA[1:0] in the sequence according to Table 7.

Table 7 - BA[1:0] Sequence

BA[1:0]	Bits in the 32-bit word
11	[7:0]
10	[15:8]
01	[23:16]
00	[31:24]

CB[6:0] - Check Bits (bi-directional)

CB[6:0] is the EDAC checkword over the 33-bit data bus consisting of D[31:0] and the parity bit (DPARIO). When IU performs a write operation to the main memory, the MEC will assert the EDAC checkword on the CB[6:0]. During read access from the main memory, CB[6:0] are input signals and will be used for checking and correction of the data word and the parity bit. During read access to areas which do not generate a parity bit, the MEC will latch the data from the accessed address and drive the correct parity bit on the DPARIO pin.

ALE* - Address Latch Enable (output)

This output is asserted when the address from the IU or a DMA unit is to be latched by an external latch. The signal is intended to be used to enable the clock input of a flip-flop used to latch the address from the IU.

PROM8* - Select 8-bit Wide PROM (input)

This input indicates that only 8-bit wide PROM is connected to the MEC. The eight data lines from the PROM is to be connected to the D[7:0] signals. The MEC will perform a 8-bit to 32-bit conversion when the IU reads from the PROM. There is no EDAC or parity checking on accesses to the PROM when PROM8 is asserted, and EDAC and parity bits must be supplied by the PROM when PROM8 is deasserted.

ROMCS* - PROM Chip Select (output)

This output is asserted whenever there is an access to the PROM. It can be connected directly to the PROM chip select pins.

MEMCS*[9:0] - Memory Chip Select (output)

MEMCS*[9:0] is asserted during an access to the main memory. MEMCS*[9:8] are redundant signals, used to substitute any of the nominal memory banks when memory connected to any of MEMCS*[7:0] malfunctions.

OE*[1:0] - Output Enable (output)

OE*[1:0] are asserted during read accesses to the main memory and is used to control memory devices with output enable features. Two signals are provided in order to avoid an external buffer, since a single OE* signal would be too heavily loaded in typical system.

MEMWR1*[1:0] - Memory Write (output)

MEMWR1* is asserted during write access to RAM, extended RAM, boot PROM extended boot PROM. It is intended to be used as write strobe to the memory devices. If latching buffers are used for the data bus, this signal can be used as a strobe to latch the data and the MEMWR2* signal can be used to write the data into the main memory. Two signals are provided in order to avoid an external buffer, since a single signal would be too heavily loaded in typical system.

MEMWR2*[1:0] - Check Bit Write (output)

MEMWR2* is asserted during write access to RAM, extended RAM, boot PROM extended boot PROM and exchange memory. It is intended to be used as write strobe to check bit memory devices, if implemented. If latching buffers are used for the data bus, this signal can be used to write both the check bits into the check bit memory and the data bits into the main memory. Two signals are provided in order to avoid an external buffer, since a single signal would be too heavily loaded in typical system.

RAMBEN* - RAM Buffer Enable (output)

RAMBEN* is asserted during memory accesses to RAM. It is intended to be used as buffer enable for data and check bit buffers in the RAM.

ROMBEN* - Boot PROM Buffer Enable (output)

ROMBEN* is asserted during memory accesses to boot PROM. It is intended to be used as buffer enable for data and check bit buffers in the boot PROM areas.

MEMBEN* - Memory Buffer Enable (output)

MEMBEN* is asserted during memory accesses to both RAM and boot PROM. It is intended to be used as buffer enable for data and check bit buffers in the RAM and boot PROM areas if RAM and boot PROM share the same buffers.

DDIR - Data Direction (output)

DDIR is used for determining the direction of the data buffers connected between the local ERC32 bus and the ERC32 system bus. The DDIR is asserted when the data flows from the local bus to the system bus i.e. during write operations. It is valid during all memory accesses.

DDIR* - Data Direction (output)

DDIR* is used for determining the direction of the data buffers connected between the local ERC32 bus and the ERC32 system bus. The DDIR* is asserted when the data flows from the local bus to the system bus i.e. during write operations. It is valid during all memory accesses.

IOSEL*[3:0] - IO Chip Select (output)

These four select signals are used to enable one of four possible I/O address areas.

IOWR* - IO Write (output)

IOWR* is asserted during write operations to the I/O area, extended I/O area and the exchange memory area.

IOBEN* - IO Buffer Enable (output)

IOBEN* is asserted during I/O access, extended I/O area extended general area and exchange memory access in order to enable the data buffers for the I/O and exchange memory.

EXMCS* - Exchange Memory Chip Select (output)

EXMCS* is asserted when the exchange memory is accessed.

BUSRDY* - Bus Ready (input)

BUSRDY* is to be generated by a unit in the I/O area, exchange memory area or in the extended areas, which requires extended time when accessed in addition to the preprogrammed number of wait states. (Note however that waitstates can not be preprogrammed for units in the extended general area, only for extended I/O, boot PROM and RAM)

BUSERR* - Bus Error (input)

BUSERR* is to be generated together with BUSRDY* by a unit in the I/O area, exchange memory area or in the extended areas if an error is detected by the accessed unit during an access.

DMAREQ* - DMA Request (input)

DMAREQ* is to be issued by a unit requesting the access to the processor bus as a master.

DMAGNT* - DMA Grant (output)

DMAGNT* is generated by the MEC as a response to a DMAREQ*. DMAGNT* is sent after that the MEC has asserted BHOLD* and deasserted AOE*, DOE*, and COE* for holding and three-stating the IU.

4.2.3. Interrupt and Control Signals

IRL[3:0] - Interrupt Request Level (output)

The state of these pins defines the Interrupt Request Level (IRL). IRL[3:0] = 0000 indicates that no external interrupts are pending and is the normal state of the IRL pins. IRL[3:0] = 1111 signifies a nonmaskable interrupt. All other interrupt levels are maskable by the Processor Interrupt Level (PIL) field of the Processor State Register (PSR). External interrupts are latched and prioritized by the MEC before they are passed to the IU.

INTACK - Interrupt Acknowledge (input)

INTACK is asserted by the IU when an external interrupt is taken, not when it is sampled and latched. The MEC will clear the corresponding pending interrupt when INTACK is asserted.

EXTINT[4:0] - External Interrupt (input)

The five external interrupt inputs are programmable to be level or edge sensitive, and active high (rising) or active low (falling).

EXTINTACK - External Interrupt Acknowledge (output)

EXTINTACK is for giving acknowledge to an interrupting unit which requires such a signal. It is programmable to which of the five external interrupt input it is associated. It is issued as soon as the IU has recognized the interrupt by asserting the INTACK signal.

SYSRESET* - System Reset (input)

Assertion of this pin will reset the MEC. Following this the MEC will then assert RESET* for a minimum of sixteen clock cycles. SYSRESET* must be asserted for a minimum of four clock cycles.

RESET* - Reset (output)

RESET* will be asserted when the IU and the FPU is to be synchronously reset. This occurs when either SYSRESET* is asserted or the MEC initiate a reset due to an error or a programming command.

IUERR* - IU Error (input)

This input is connected to the ERROR* output of the (master) IU and is asserted when the (master) IU enters error mode.

IUHWERR* - IU Hardware Error (input)

This input is connected to the HWERR* output of the (master) IU and is asserted when the IU detects an internal hardware error.

IUCMPERR* - IU Comparison Error (input)

This input is connected to the CMPERR* signal of the slave IU in a master/slave configuration and is asserted when there is a comparison error.

FPUHWERR* - FPU Hardware Error (input)

This input is connected to the HWERROR* output of the (master) FPU and is asserted whenever there is an error in the (master) FPU.

FPUCMPERR* - FPU Comparison Error (input)

This input is connected to the CMPERR* signal of the slave FPU in a master/slave configuration and is asserted when there is a comparison error.

MECHWERR* - MEC Hardware Error (output)

MECHWERR is an output indicating that a hardware error has been detected in the MEC.

SYSERR* - System Error (output)

This output is asserted whenever an unmasked error is set in the ERSR register. It stays asserted until the ERSR is cleared. The error can originate from either the IU, the FPU, or the MEC itself. SYSERR* is used to signal to the system outside the ERC32 based computer.

SYSAV - System Availability (output)

This signal is asserted whenever the system is available, i.e. when the SYSAV bit in the ERSR is set and the CPUHALT* and SYSERR* signals are deasserted. The SYSAV bit is cleared by reset and is programmable by software.

SYSHALT* - System Halt (input)

SYSHALT* is used by the system outside to halt the ERC32. By asserting this signal, the MEC will assert CPUHALT* halting the IU and the FPU. This signal could be used for testing through the DMA or the TAP interface.

NOPAR* - No Parity (input)

Assertion of this signal will disable the parity checking of all signals related to the ERC32 local buses. The parity generation on the data bus (towards memory and IO units) is not affected by this signal, but note that parity checking is disabled if NOPAR* is asserted. This is a static signal and shall not change when running.

ROMWRT* - ROM Write Enable (input)

Assertion of this signal will validate (allow) programming (write operations) of the boot PROM when EEPROM devices are used.

CPUHALT* - Processor (IU and FPU) Halt (output)

This output is intended to be connected to the HALT* inputs of the IU and of the FPU and is used to halt the IU, the FPU and possibly other units in the system.

4.2.4. Test Access Port Signals

The following Test Access Port interface (IEEE standard 1149.1) is used to perform boundary scan for test and debugging purposes.

TCK - Test Clock (input)

Test clock for scan registers.

TRST* - Test Reset (input)

Reset the TAP controller.

TMS - Test Mode Select (input)

Selects test mode of the TAP controller.

TDI - Test Data Input (input)

Test scan register data input.

TDO - Test Data Output (output)

Test scan register data output, not affected by MODE.

4.2.5. UART Interface

WDCLK - Watch Dog Clock (input)

WDCLK is the WD clock input but this clock can also be used as a clock input for the UART interface. The clock frequency of WDCLK must be less than the clock frequency of SYSCLK, i.e. $f_{WDCLK} < f_{SYSCLK}$.

RXA - Receive Data channel A (input)

RXA is the serial data input for channel A of the UART.

RXB - Receive Data channel B (input)

RXB is the serial data input for channel B of the UART.

TXA - Transmit Data channel A (output)

TXA is the serial data output for channel A of the UART.

TXB - Transmit Data channel B (output)

TXB is the serial data output for channel B of the UART.

4.2.6. Power and Clock Signals

CLK2 - Double Frequency Clock (input)

CLK2 is the input clock to the ERC32 hardware. The frequency of this clock must be twice the clock frequency used to clock the IU and the FPU. Note that the external timing of the MEC is affected by the duty cycle of CLK2, as some MEC output signals are latched with respect to the edges of CLK2.

SYSCLK[1:0] - Clock (output)

SYSCLK is a nominally 50% duty-cycle clock generated by the MEC from CLK2 and is used for clocking the IU and the FPU as well as other system logic. The SYSCLK is used as input clock during MEC slave mode.

VCCI, VCCO - Power (inputs)

These pins provide +5 V power to various sections of the MEC. Power is supplied on two different buses to provide clean, stable power to each section: output drivers, and the main internal circuitry. VCCO pins supply the output driver bus; and the VCCI pins supply main internal circuitry.

VSSI, VSSO - Ground (inputs)

These pins provide ground return for the power signals. Ground is supplied on different buses to match the power signals to each section: VSSO pins for the output driver bus; VSSI pins for the main internal circuitry bus.

5. ELECTRICAL AND MECHANICAL SPECIFICATION

5.1. Maximum Rating and DC Characteristics

5.1.1. Maximum Ratings

Storage Temperature	-65°C to 150°C
Ambient Temperature with power applied	-55°C to 125°C
Supply Voltage ^[1]	-0.5 V to +7.0 V
Input Voltage	-0.5 V to +7.0 V

5.1.2. Operating Range

Range	Ambient Temperature ^[2]	Vcc
Military	-55°C to 125°C	5 V ±10%

5.1.3. DC Characteristics over the Operating Range

Parameters	Description	Test Conditions	Min	Max	Units
VOH	Output HIGH Voltage	Vcc=Min, Ioh=-2.0mA	3.7		V
VOL	Output LOW Voltage	Vcc=Min		0.5	V
VIH	Input HIGH Voltage		2.1	Vcc	V
VIL	Input LOW Voltage		-0.5	0.8	V
IIZ	Input Leakage Current	Vcc=Max, Vss≤VIN≤Vcc	-10	10	µA
IOZ	Output Leakage Current	Vcc=Max, Vss≤Vout≤ Vcc	-15	15	µA
ISC	Output Short Circuit Current	Vcc=Max, Vout=0V	-30	-350	mA
ICCop	Supply Current (All outputs loaded to 50 pF)	Vcc=5V, f=20 MHz	-	100	mA
ICCs b	Standby Current	Vcc=5V, f=0 MHz	-	1	mA

Notes:

1. All power and ground pins must be connected before power is applied.
2. Ambient temperature is defined as the 'instant on' case temperature.

5.1.4. Capacitance Ratings

ERC32 MEC		
Parameters	Description	Max. (pF)
CIN	Input Capacitance	8
CIO	Input/Output Bus Capacitance	10

5.2. Package Description

5.2.1. Pin Assignments

Signal	Pin	Signal	Pin	Signal	Pin	Signal	Pin	Signal	Pin	Signal	Pin
A0	189	ASI3	190	D21	30	IOSEL3*	113	ROMCS*	111	VCCO15	26
A1	185	ASPAR	195	D22	29	IOWR*	119	ROMWRT*	251	VCCO16	20
A2	182	BA0	76	D23	28	IRL0	208	RXA	186	VCCO17	14
A3	181	BA1	71	D24	23	IRL1	205	RXB	184	VSSI1	192
A4	180	BHOLD*	148	D25	24	IRL2	206	SIZE0	199	VSSI2	163
A5	179	BUSERR*	130	D26	21	IRL3	203	SIZE1	198	VSSI3	144
A6	178	BUSRDY*	134	D27	22	IUCMPERR*	247	SYSAV	138	VSSI4	136
A7	177	CB0	9	D28	17	IUERR*	245	SYSCLK_0	236	VSSI5	64
A8	176	CB1	10	D29	18	IUHWERR*	246	SYSCLK_1	235	VSSO1	252
A9	174	CB2	12	D30	15	LDSTO	223	SYSERR*	129	VSSO2	210
A10	175	CB3	8	D31	16	LOCK	220	SYSHALT*	250	VSSO3	122
A11	172	CB4	7	DDIR	99	MDS*	254	SYSRESET*	70	VSSO4	106
A12	173	CB5	6	DDIR*	98	MECHWERR*	200	TCK	141	VSSO5	94
A13	170	CB6	5	DMAAS	232	MEMBEN*	104	TDI	133	VSSO6	88
A14	171	CLK2	239	DMAGNT*	231	MEMCS0*	92	TDO	131	VSSO7	82
A15	168	COE*	143	DMAREQ*	228	MEMCS1*	91	TMS	139	VSSO8	69
A16	167	CPUHALT*	202	DOE*	142	MEMCS2*	90	TRST*	137	VSSO9	58
A17	166	D0	66	DPARIO	253	MEMCS3*	89	TXA	191	VSSO10	52
A18	165	D1	62	DRDY*	227	MEMCS4*	86	TXB	187	VSSO11	46
A19	164	D2	63	DXFER	222	MEMCS5*	83	VCCI1	248	VSSO12	41
A20	162	D3	60	EXMCS*	110	MEMCS6*	84	VCCI2	211	VSSO13	33
A21	161	D4	59	EXTCCV	226	MEMCS7*	81	VCCI3	140	VSSO14	27
A22	160	D5	56	EXTHOLD*	225	MEMCS8*	80	VCCI4	68	VSSO15	19
A23	159	D6	54	EXTINT0	128	MEMCS9*	75	VCCI5	1	VSSO16	13
A24	158	D7	55	EXTINT1	127	MEMWR1_0*	103	VCCO1	2	VSSO17	4
A25	157	D8	50	EXTINT2	126	MEMWR1_1*	102	VCCO2	242	WDCLK	238
A26	155	D9	51	EXTINT3	125	MEMWR2_0*	101	VCCO3	209	WE*	215
A27	154	D10	48	EXTINT4	124	MEMWR2_1*	100	VCCO4	121	WRT	219
A28	153	D11	49	EXTINTACK	132	MEXC*	255	VCCO5	105		
A29	152	D12	45	FPUCMPERR*	244	MHOLD*	256	VCCO6	93		
A30	150	D13	42	FPUHWERR*	243	NOPAR*	147	VCCO7	85		
A31	151	D14	43	IMPAR	237	OE0*	213	VCCO8	79		
ALE*	95	D15	40	INTACK	214	OE1*	212	VCCO9	65		
AOE*	145	D16	37	INULL	224	PROM8*	146	VCCO10	61		
APAR	197	D17	36	IOBEN*	118	RAMBEN*	107	VCCO11	53		
ASIO	196	D18	35	IOSEL0*	116	RESET*	3	VCCO12	47		
ASH	193	D19	34	IOSEL1*	115	RD	216	VCCO13	38		
ASI2	194	D20	31	IOSEL2*	112	ROMBEN*	108	VCCO14	32		

5.2.2. Package Diagram

APPENDIX 1
TIMING DIAGRAMS

(SYSCLK @ 10 MHz)

Figure	Diagram Name	Issue
1.	CLK2 to SYSCLK Skew	3
2.	RAM Load-Store sequence at 0 WS with EDAC and/or Parity Protection	4
3.	RAM Load at 1 waitstate with EDAC and/or Parity Protection	3
4.	RAM Store at 1 waitstate with EDAC and/or Parity Protection	4
5.	RAM Load with Correctable Error	3
6.	RAM Load with Uncorrectable Error	3
7.	RAM Load at 1 Waitstate with Access Violation	3
8.	RAM Store at 1 Waitstate with Access Violation	3
9.	RAM Store at 0 Waitstate with Access Violation	3
10.	RAM Store Byte/Halfword with No Error / Correctable Error	4
11.	RAM Store Byte/Halfword with Uncorrectable Error	4
12.	RAM Store Double	4
13.	RAM Store Double with exception in 2:nd word	4
14.	PROM bytewise Load at 2 waitstates	3
15.	PROM bytewise Store at 1 waitstate	4
16.	PROM 40-bit wide Load at 2 waitstate	3
17.	PROM 40-bit wide Store at 1 waitstate	3
18.	MEC Register Load	3
19.	MEC Register Store	4
20.	Exchange Memory Load with no parity or EDAC protection	3
21.	Exchange Memory Store with EDAC and/or parity protection	4
22.	Exchange Memory Load with Busy and with EDAC and/or parity protection	3
23.	Exchange Memory Store with Busy and with EDAC and/or parity protection	4
24.	IO Load at 3 waitstates	3
25.	IO Store at 2 waitstates	4
26.	IO Load with Busy	3
27.	IO Store at 0 waitstate with Busy	4
28.	Extended Area Load with Busy	3
29.	Extended Area Store with Busy	4
30.	DMA RAM Load	3
31.	DMA RAM Store	4
32.	DMA IO Load	3
33.	DMA IO Store	4
34.	DMA IO Load with Exception	3
35.	DMA RAM Load with Correctable Error	3
36.	DMA RAM Load with Uncorrectable Error	3
37.	Power Down Mode after writing to Power Down Register	4
38.	TAP Control Timing	3
39.	Reset Timing	3
40.	Halt Timing	3
41.	External Error with Reset Timing	3
42.	External Error with CPUHALT Timing	3
43.	Internal MEC Error with Reset Timing	3
44.	Internal MEC Error with CPUHALT Timing	3
45.	Edge Triggered Interrupt Timing	3
46.	Level Triggered Interrupt Timing	3

Name	Min	Max	Comment	Reference Edge
t1	56		SYSCLK period	
t2	0,45*t3	0,55*t3	CLK2, high and low pulse width	
t3	28		CLK2 period	
t4	15		Address Input Setup Time	SYSCLK+
t5	4		Address Input Hold Time	SYSCLK+
t6	15		ASI(7:0), SIZE(1:0), RD, WRT, WE*, LOCK, LDSTO, DXFER Input Setup Time	SYSCLK+
t7	4		ASI(7:0), SIZE(1:0), RD, WRT, WE*, LOCK, LDSTO, DXFER Input Hold Time	SYSCLK+
t8		15	ALE* Output Delay	SYSCLK-
t9 *)		20	Address Valid to MEC Internal Chip Select Delay	Address Valid
t10*)		15	MEMCS*(9:0), ROMCS*, EXMCS* Maximum Clock to Output Delay	SYSCLK+
t11	1		MEMCS*(9:0), ROMCS*, EXMCS* Minimum Clock to Output Delay	SYSCLK+
t12 *)		8	MEMCS*(9:0), ROMCS*, EXMCS* Output Latch Propagation Delay	
t13		35	MEMBEN*, RAMBEN*, ROMBEN* Output Delay	CLK2+ (lo->hi), CLK2- (hi->lo)
t14		35	DDIR Output Delay	CLK2+
t15		35	MEMWR1*, MEMWR2*, IOWR* Output Delay	CLK2-
t16		35	OE* Output Delay	CLK2+ (lo->hi), CLK2- (hi->lo)
t17		20	Boot PROM Address (BA) Output Delay	SYSCLK+
t18		30	IOSEL*(3:0) Clock to Output Delay	SYSCLK- (lo->hi), SYSCLK+ (hi->lo)
t19	20		Data Setup Time During Store	SYSCLK-
t20	1		Data Hold Time During Store	SYSCLK-
t21		20	MEC Data and DPARIO Maximum Output Delay	SYSCLK-
t22	2		MEC Data and DPARIO Valid to High-Z Delay	SYSCLK+
t23		35	CB* Output Maximum Delay	SYSCLK+
t24	2		CB* Output Valid to High-Z Delay	SYSCLK+
t25		20	MEXC* Output Delay	SYSCLK-
t26		20	MHOLD*, BHOLD* Output Delay	SYSCLK+
t27 **)		20	AOE*, COE*, DOE*, TOE* Output Delay	SYSCLK+
t28	8		INTACK Input Setup Time	SYSCLK+
t29	4		INTACK Input Hold Time	SYSCLK+
t30	8		SYSRESET*, SYSHALT* Input Setup	SYSCLK+
t31	4		SYSRESET*, SYSHALT* Input Hold	SYSCLK+
t32		15	RESET*, CPUHALT* Output Delay	SYSCLK+
t35	35		INULL Input Setup	SYSCLK+
t36	4		INULL Input Hold	SYSCLK+
t37		15	MDS/DRDY* Output Delay	SYSCLK+
t38	15		BUSRDY*, BUSERR* Input Setup	SYSCLK+
t39	4		BUSRDY*, BUSERR* Input Hold	SYSCLK+
t40	15		DMAREQ* Input Setup Time	SYSCLK+
t42		15	DMAGNT* Output Delay	SYSCLK+
t43		15	IRL(3:0), EXTINTACK Output Delay	SYSCLK-
t44	8		EXTINT(4:0) Input Setup	SYSCLK-
t45	4		EXTINT(4:0) Input Hold	SYSCLK+
t46	8		IUERR*, IUHWERR, IUCMPERR*, FPUHWERR*, FPUCMPERR* Input Setup	SYSCLK+
t47	4		IUERR*, IUHWERR, IUCMPERR*, FPUHWERR*, FPUCMPERR* Input Hold	SYSCLK+
t48		15	SYSERR*, SYSAV, MECHWERR* Output Delay	SYSCLK+
t49	8		NOPAR, ROMWRT*, PROM8* Input Setup Time	SYSRESET-
t50	4		NOPAR, ROMWRT*, PROM8* Input Hold Time	SYSRESET+
t53	15		APAR, ASPAR, IMPAR Input Setup Time	SYSCLK+
t54	4		APAR, ASPAR, IMPAR Input Hold Time	SYSCLK+

t55	100	1000	TCLK Period Time	
t56	15		TRST* Input Setup	TCLK +
t57	4		TRST* Input Hold	TCLK +
t58	15		TMS Input Setup	TCLK +
t59	4		TMS Input Hold	TCLK +
t60	15		TDI Input Setup	TCLK +
t61	4		TDI Input Hold	TCLK +
t62		15	TDO Output Delay	TCLK +
t63	>t1		WDCLK Clock Period Time	
t66		35	DPARIO generation Time including Output Delay	Data Valid
t68	22		ExtHold, ExtCCV Input Setup	SYSClk+
t69		20	SYSClk High to Low Output Delay	CLK2+
t70		20	SYSClk Low to High Output Delay	CLK2+
t71	3		Data and checkbits Setup Time MEC during load	SYSClk+
t73		35	Data Valid to MHOLD* Delay when MEC checks parity and checkbits	Data Valid
t74	0		DMAAS Input Setup	SYSClk+
t75	4		DMMAS Input Hold	SYSClk-
t78	1		Data, Parity and Checkbits Hold during Load	SYSClk+

*) For the chip select timing the following formula applies:
 If (address valid before SYSClk+) > t9 then (chip select output delay time) = t10
 else (chip select output delay time) = t9+t12

**) DOE* is deasserted on SYSClk- during store byte/halfword

Abbreviations used in the timing diagrams :

FAn: Fetch address n, LAn: Load address n,
 SAN: Store address n, TAn: Trapp address n

FDn: Fetch data n, LDn: Load data n,
 SDn: Store data n, TDn: Trapp data n,

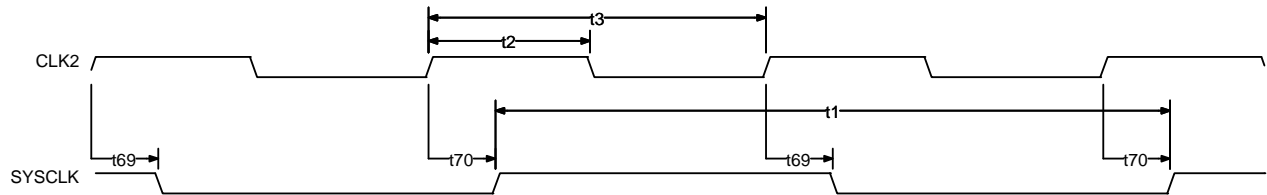

Figure 1) CLK2 to SYSCLK Skew

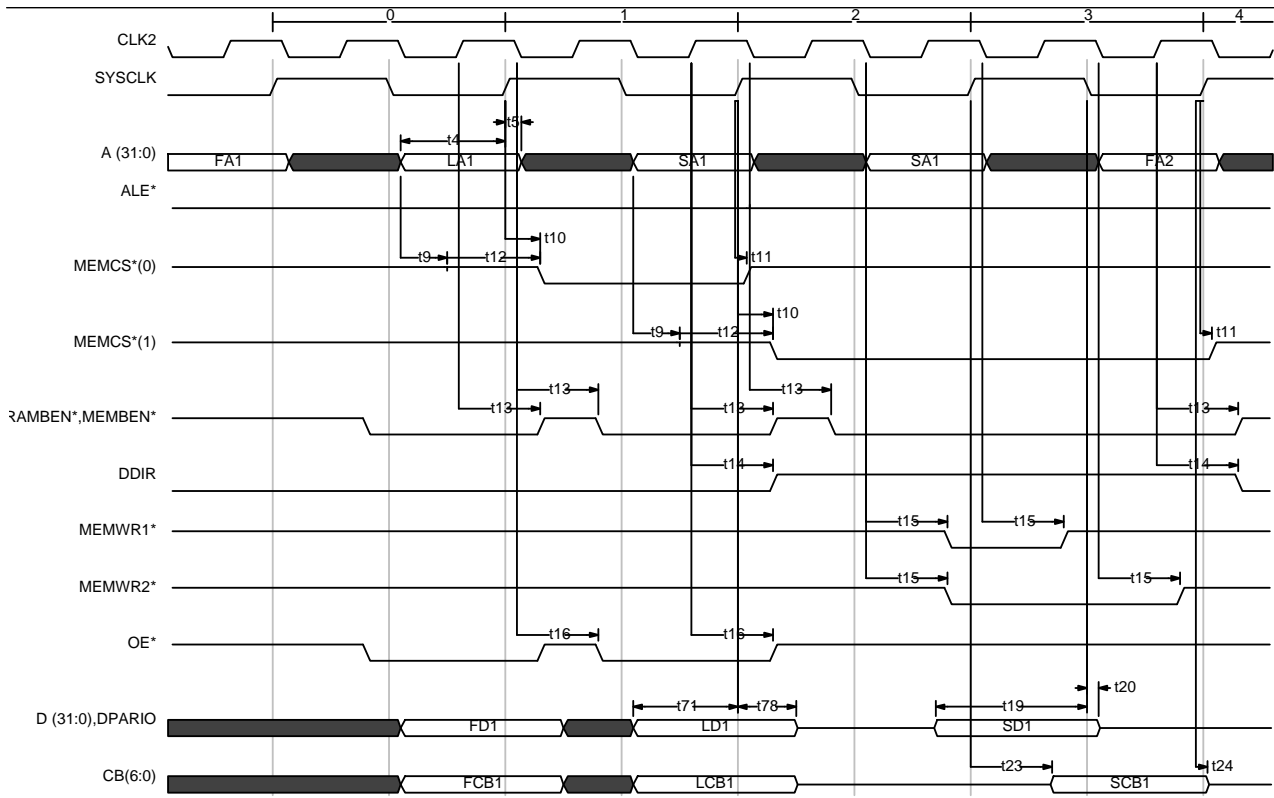

Figure 2) RAM Load-Store Sequence at 0 Waitstates with EDAC and/or Parity Protection

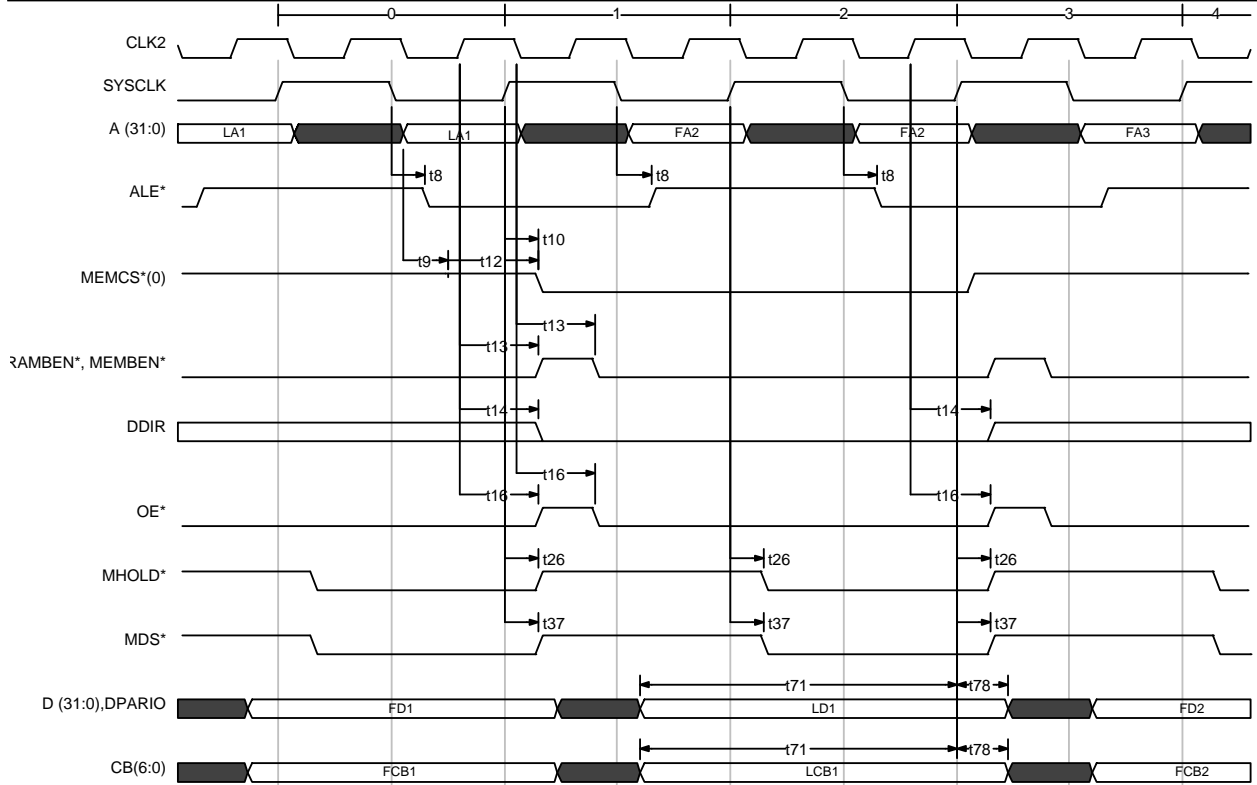

Figure 3) RAM Load at 1 waitstate with EDAC and/or Parity Protection

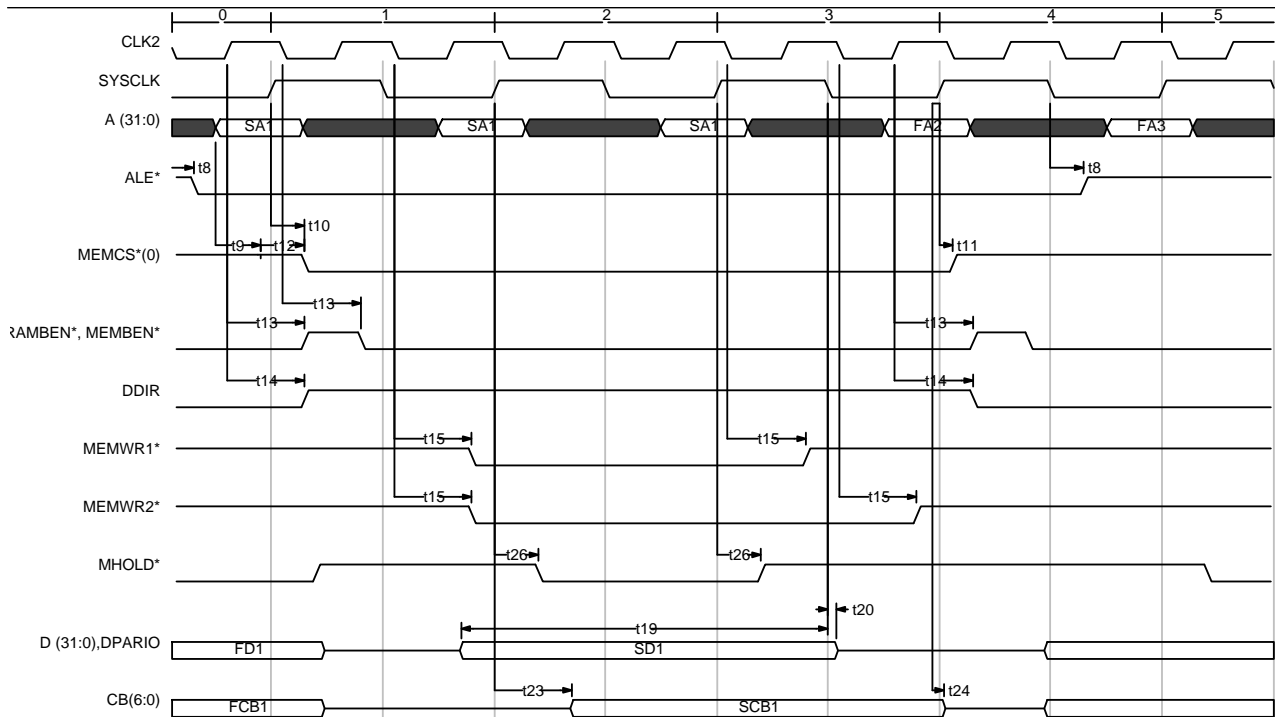

Figure 4) RAM Store at 1 waitstate with EDAC and/or Parity Protection

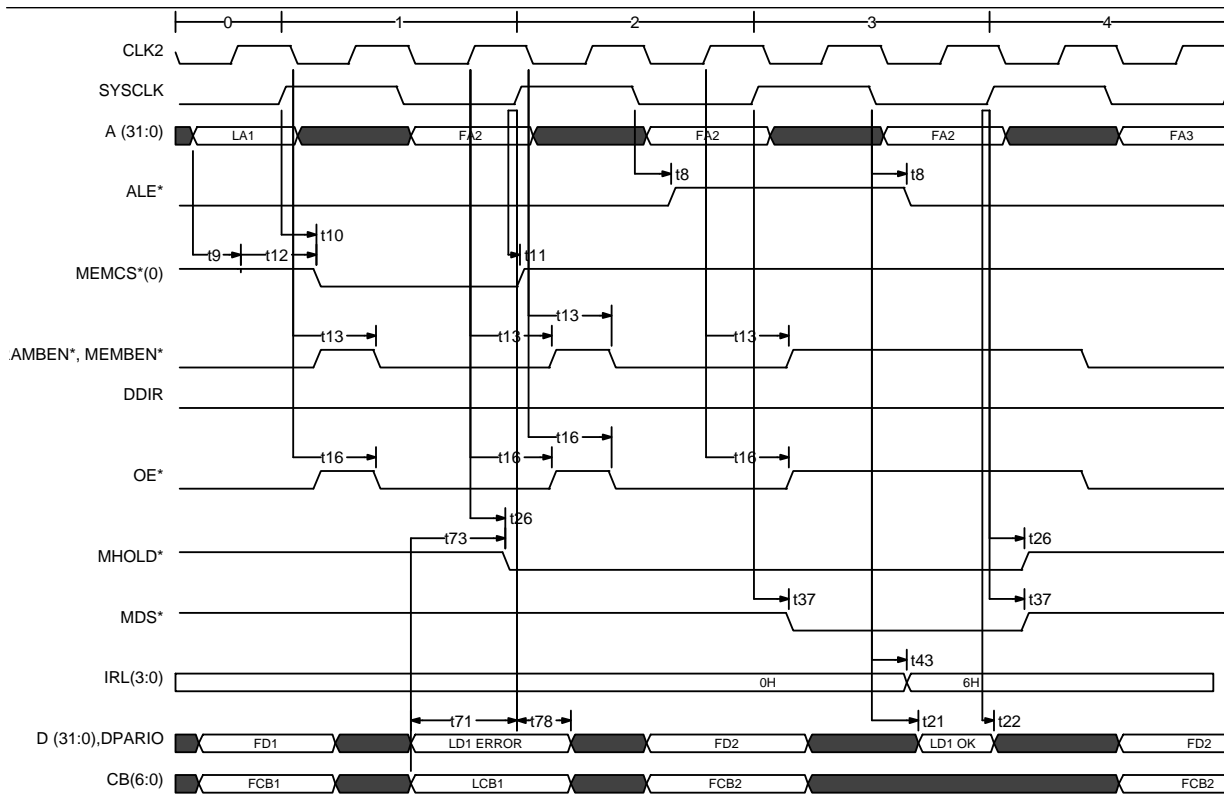

Figure 5) RAM Load at 0 waitstate with Correctable Error

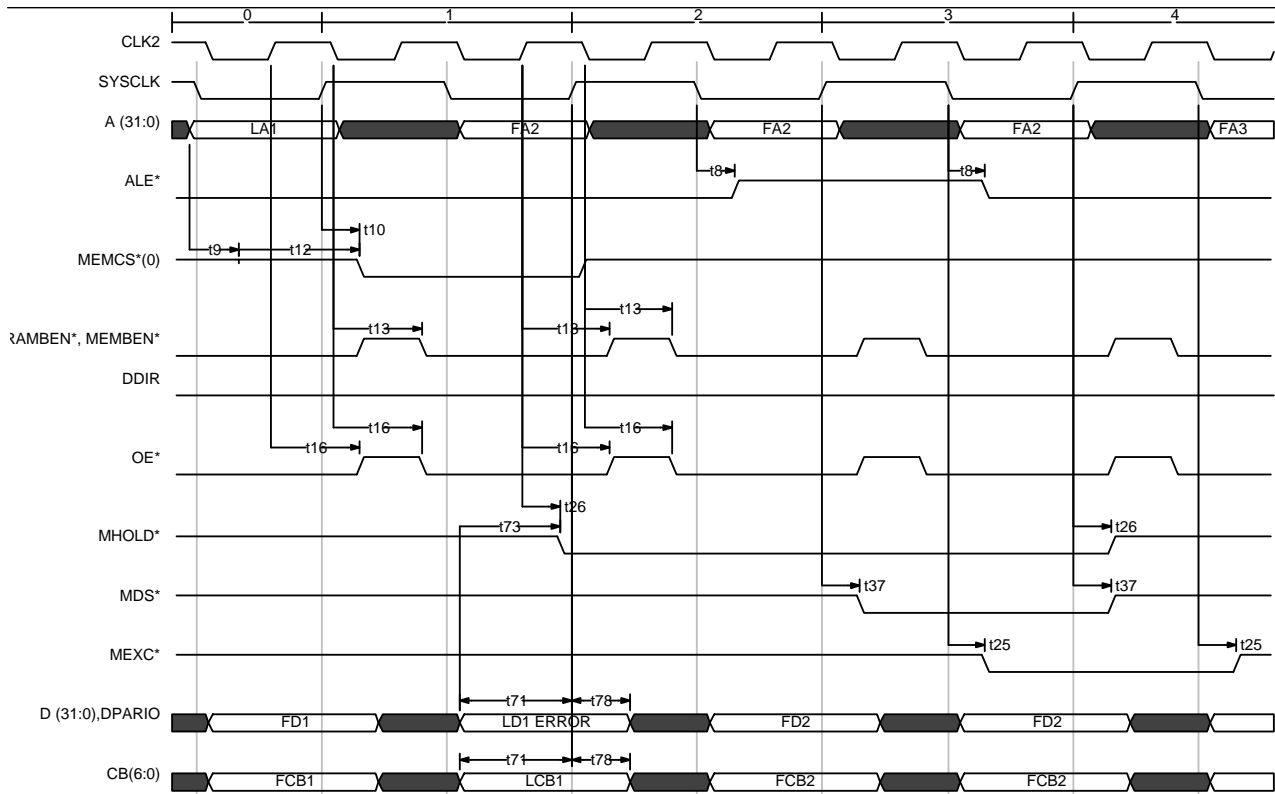

Figure 6) RAM Load with Uncorrectable Error at 0 WS

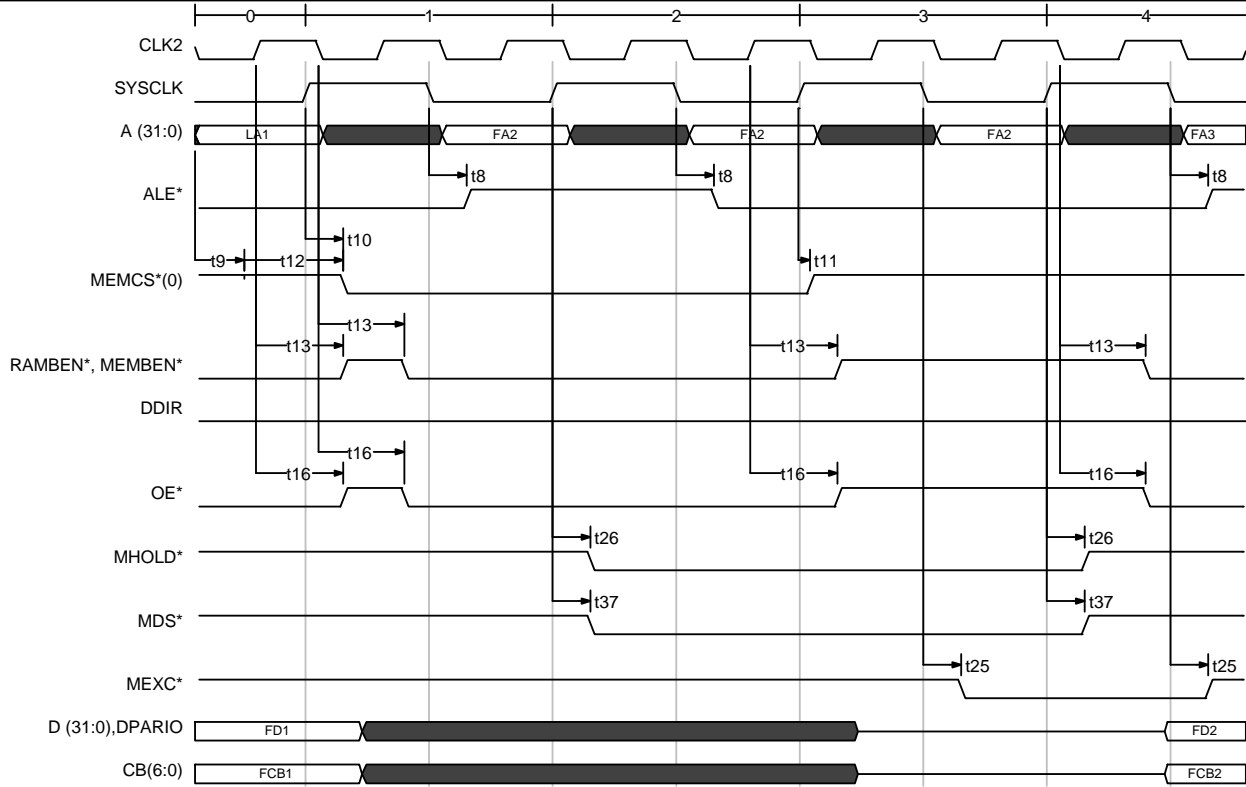

Figure 7) RAM Load at 1 Waitstate with Access Violation

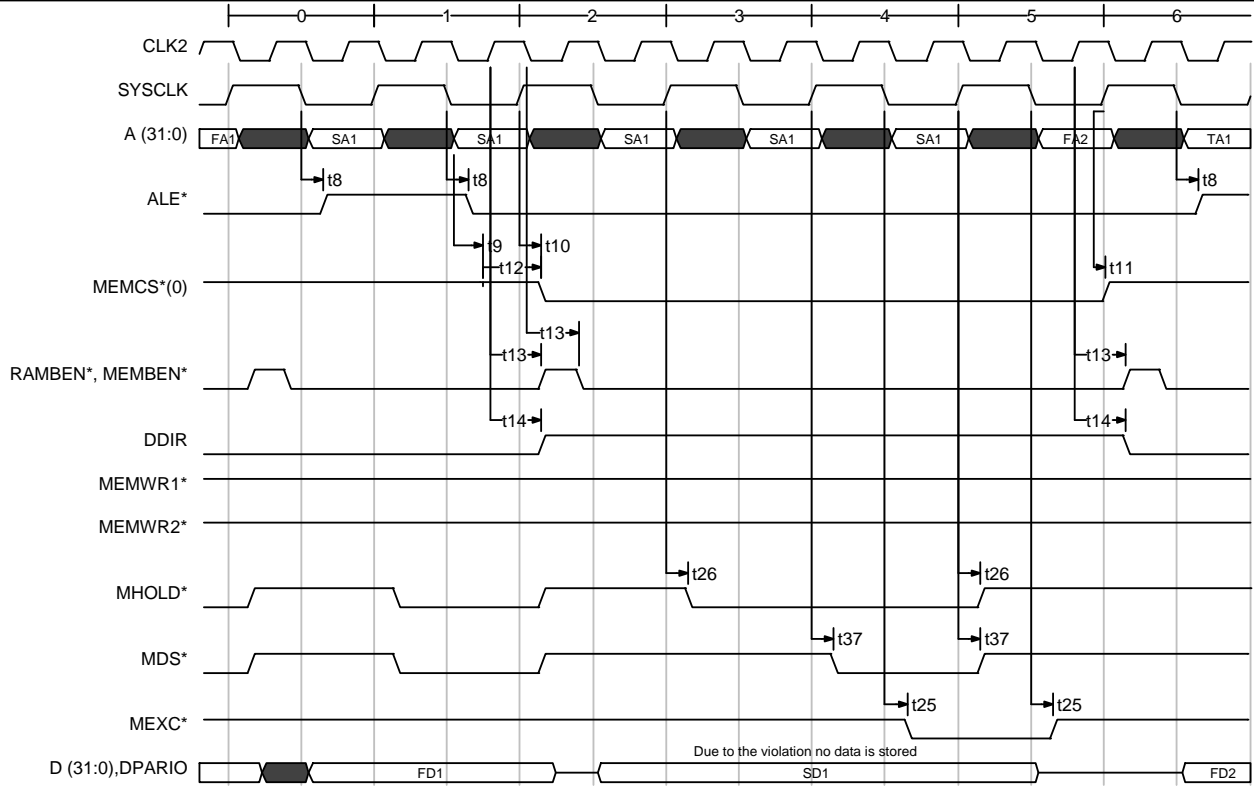

Figure 8) RAM Store at 1 waitstate with Access Violation

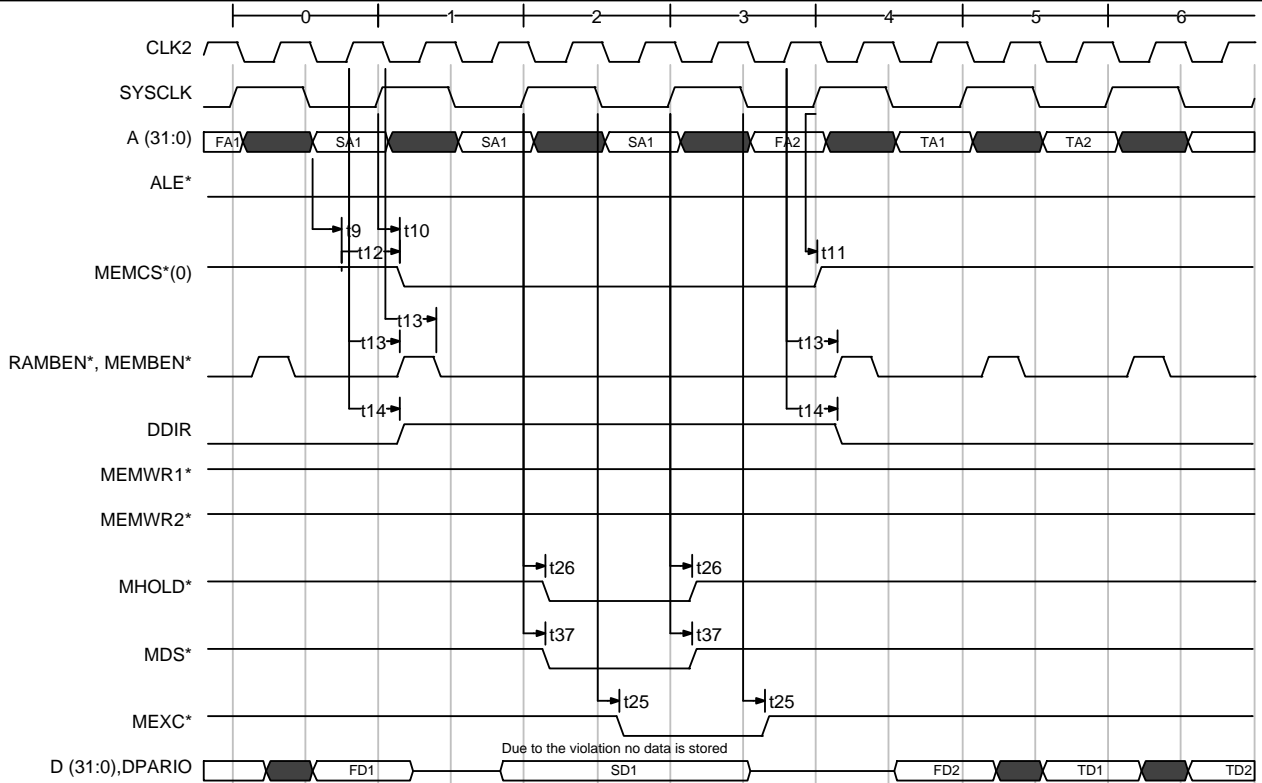

Figure 9) RAM Store at 0 waitstate with Access Violation

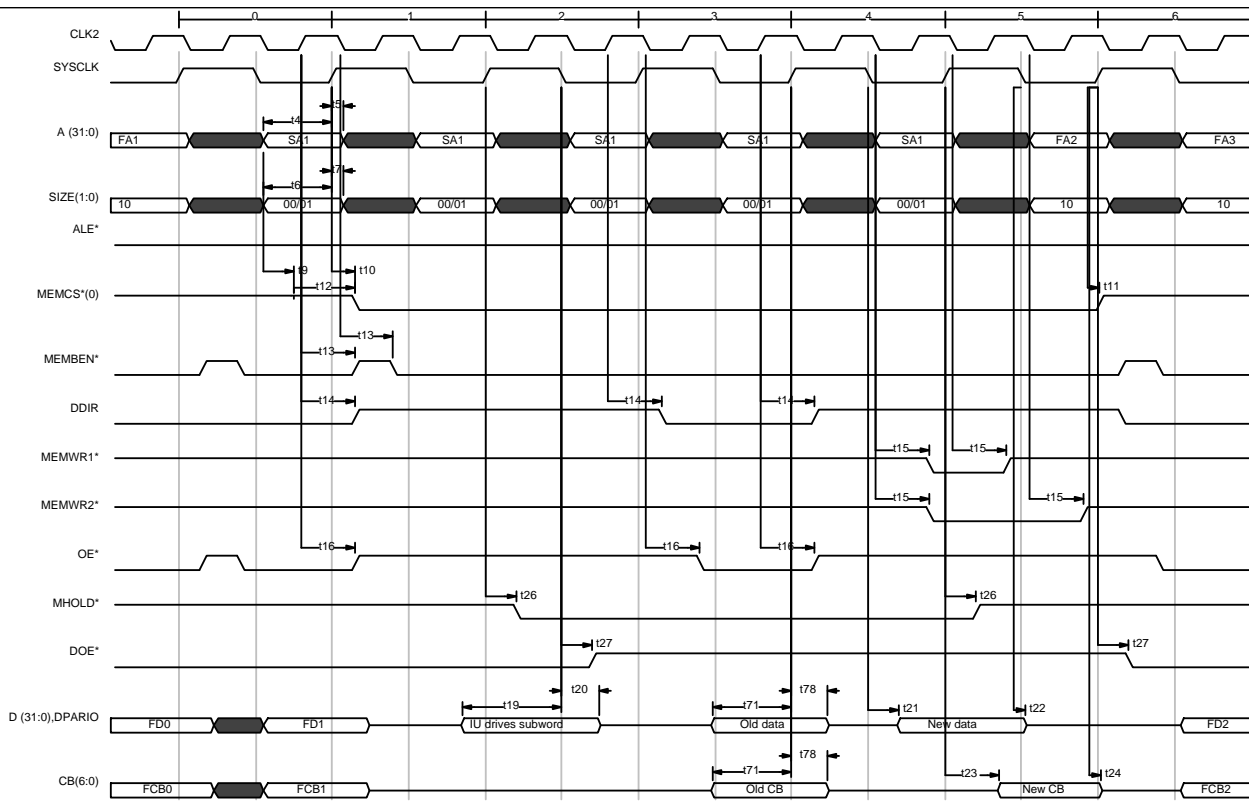

Figure 10) RAM Store Byte/Halfword with No Error / Correctable Error

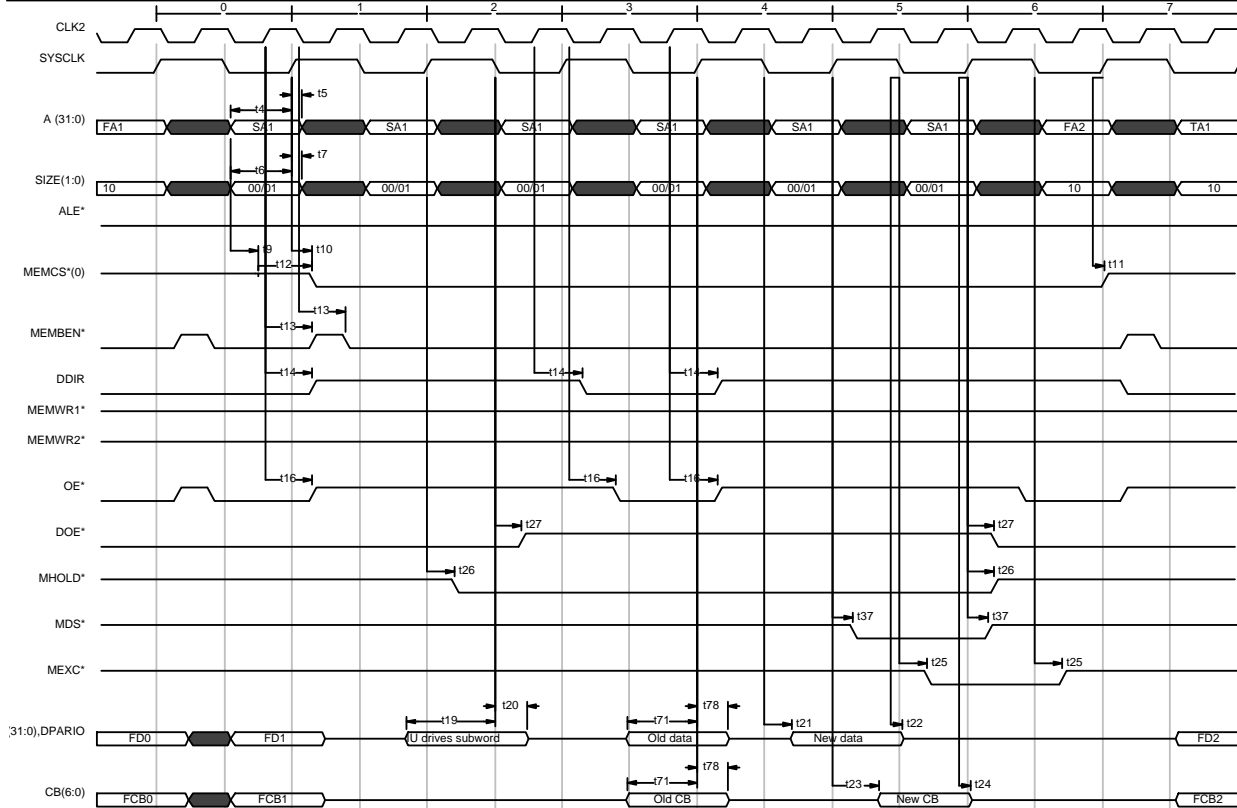

Figure 11) RAM Store Byte/Halfword with Uncorrectable Error

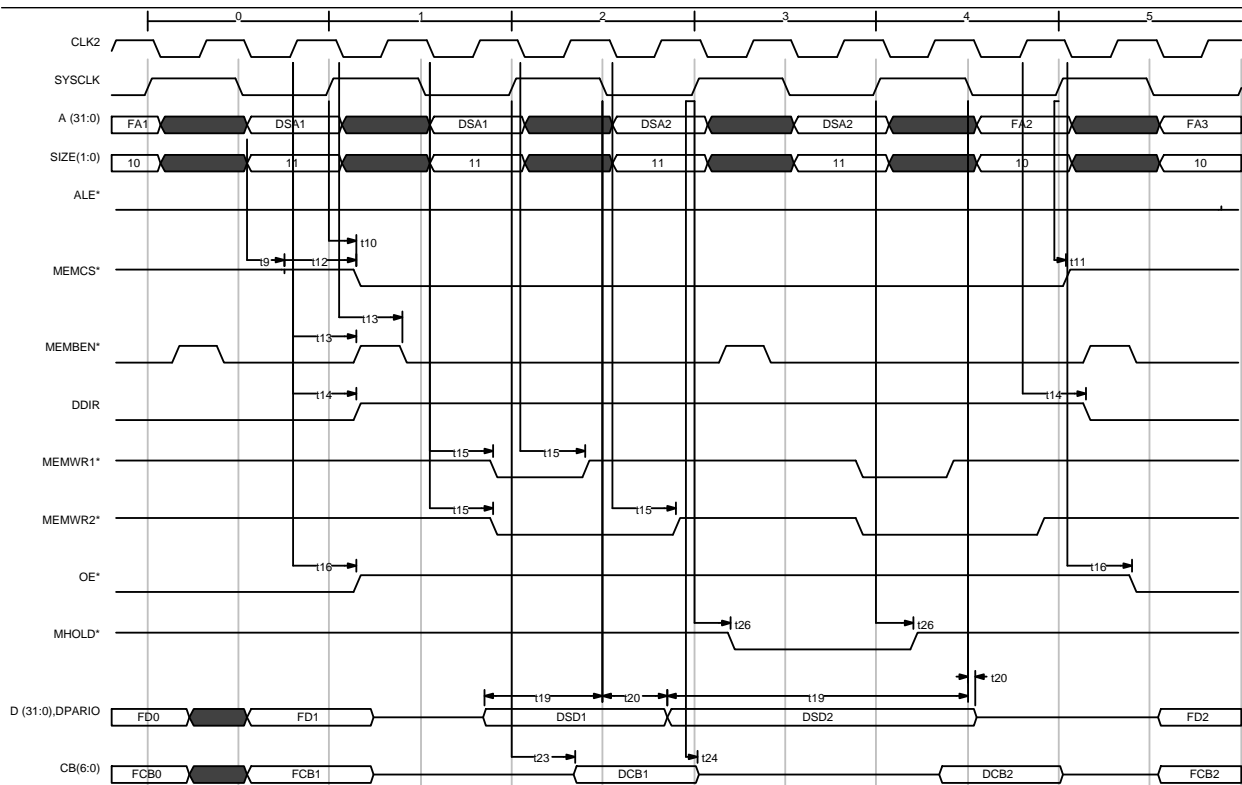

Figure 12) RAM Store Double at 0 WS

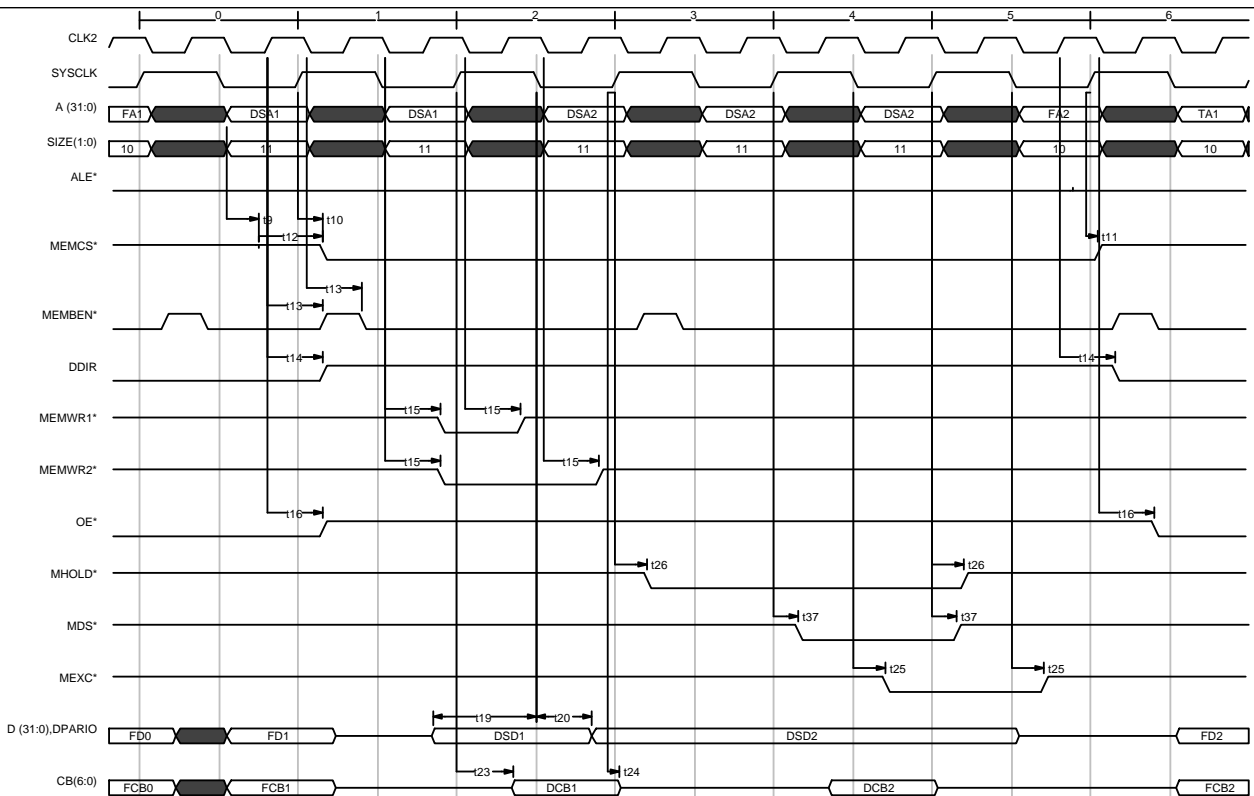

Figure 13) RAM Store Double at 0 WS with exception in 2:nd word

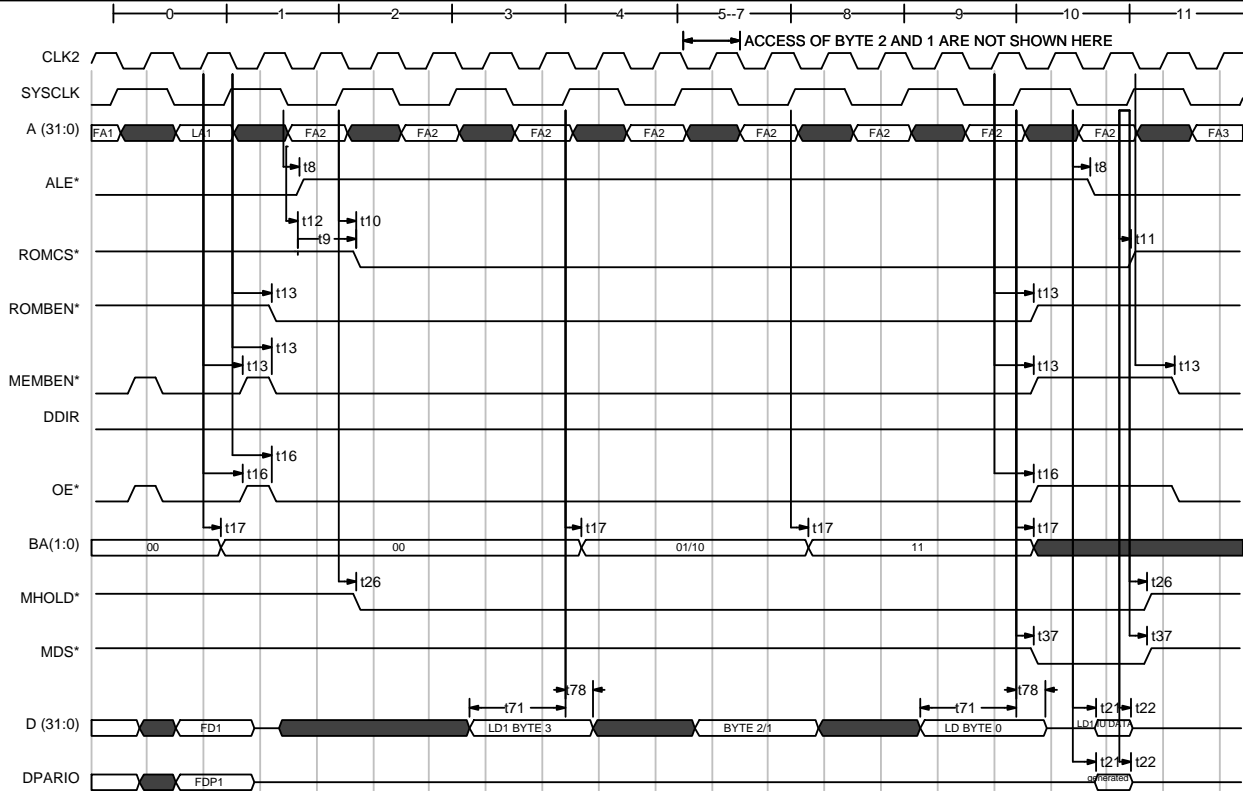

Figure 14) PROM bitwise Load at 2 waitstates

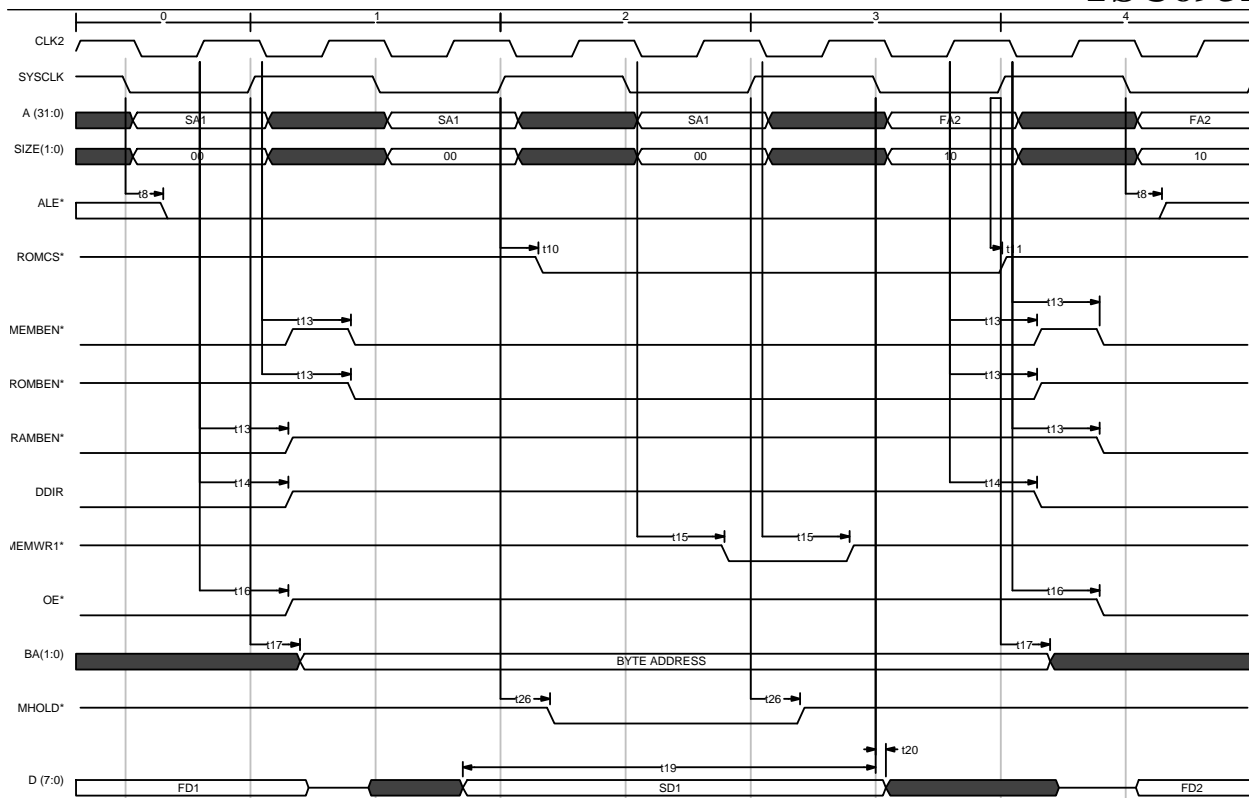

Fig 15) PROM Byte-wide Store at 1 WS

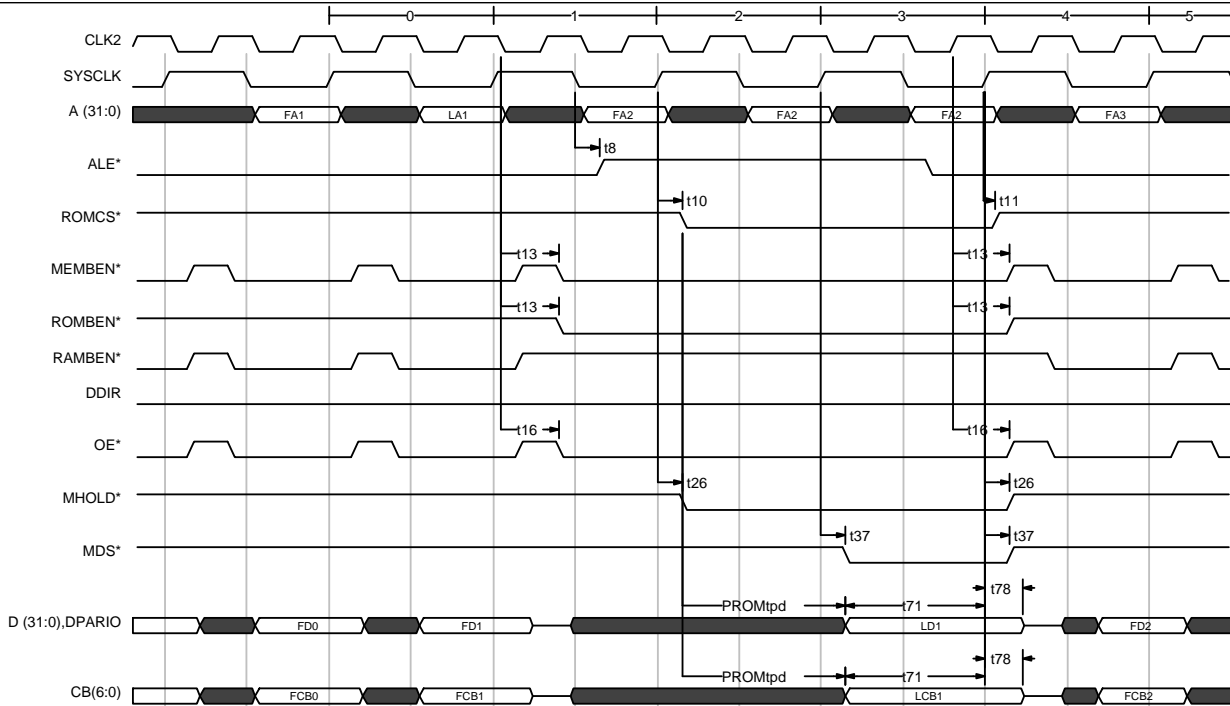

Fig 16) PROM 40 bit wide load at 2 WS

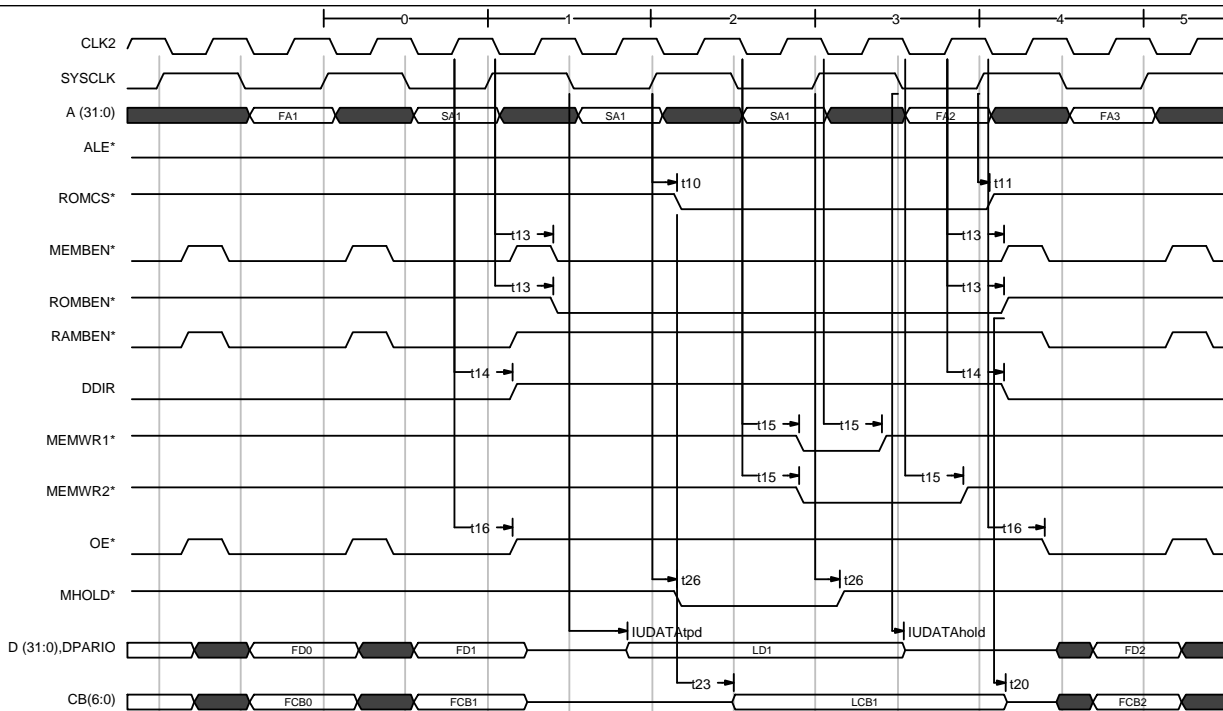

Fig 17) PROM 40 bit wide store at 1 WS

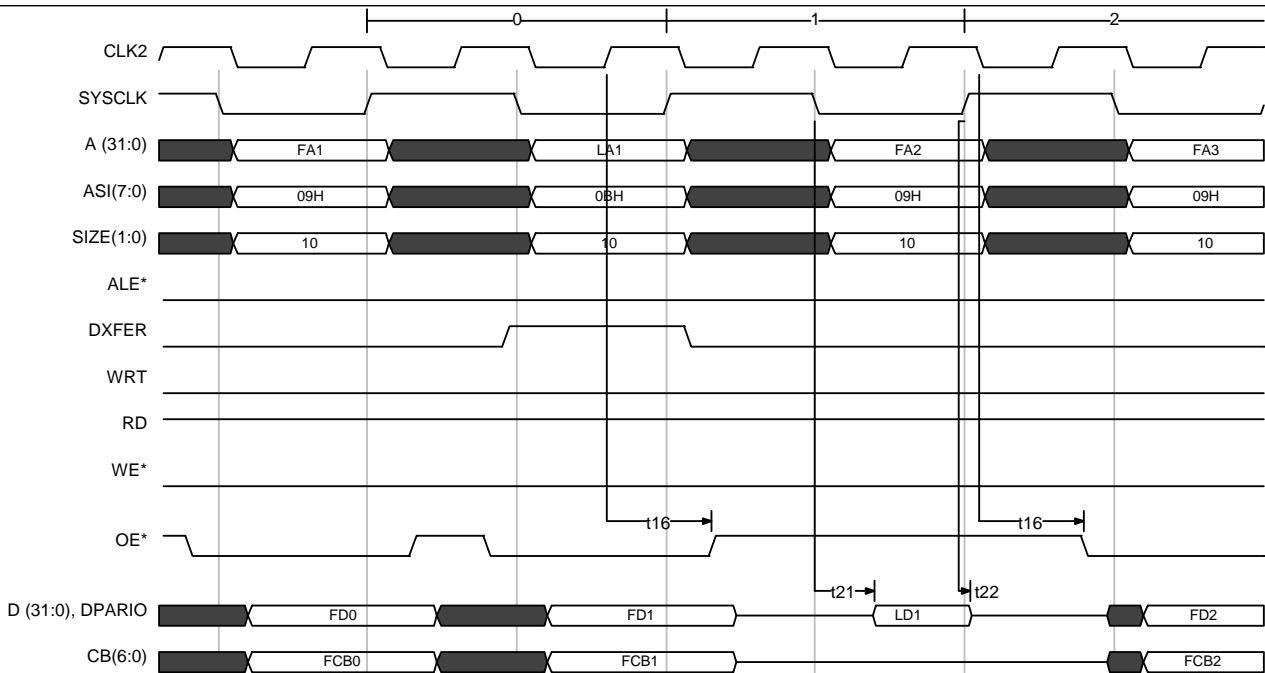

Fig 18) MEC Register Load

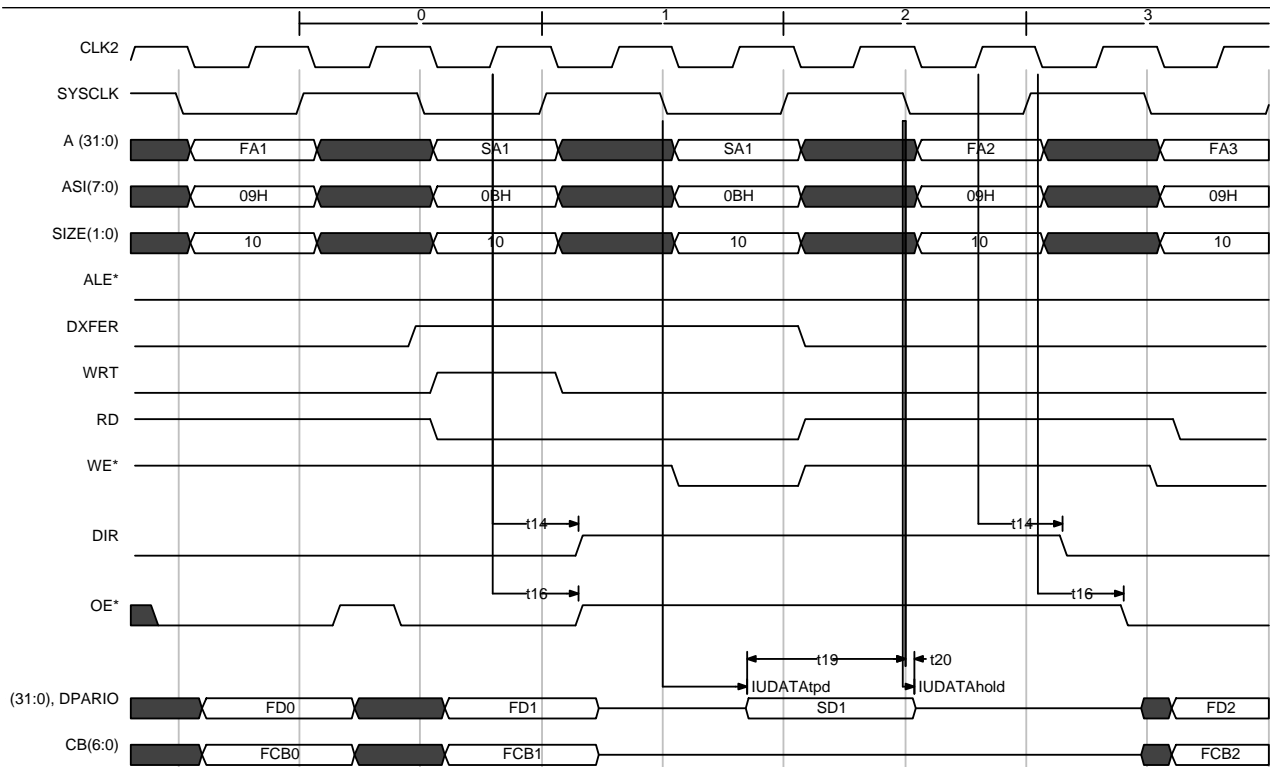

Fig 19) MEC Register Store

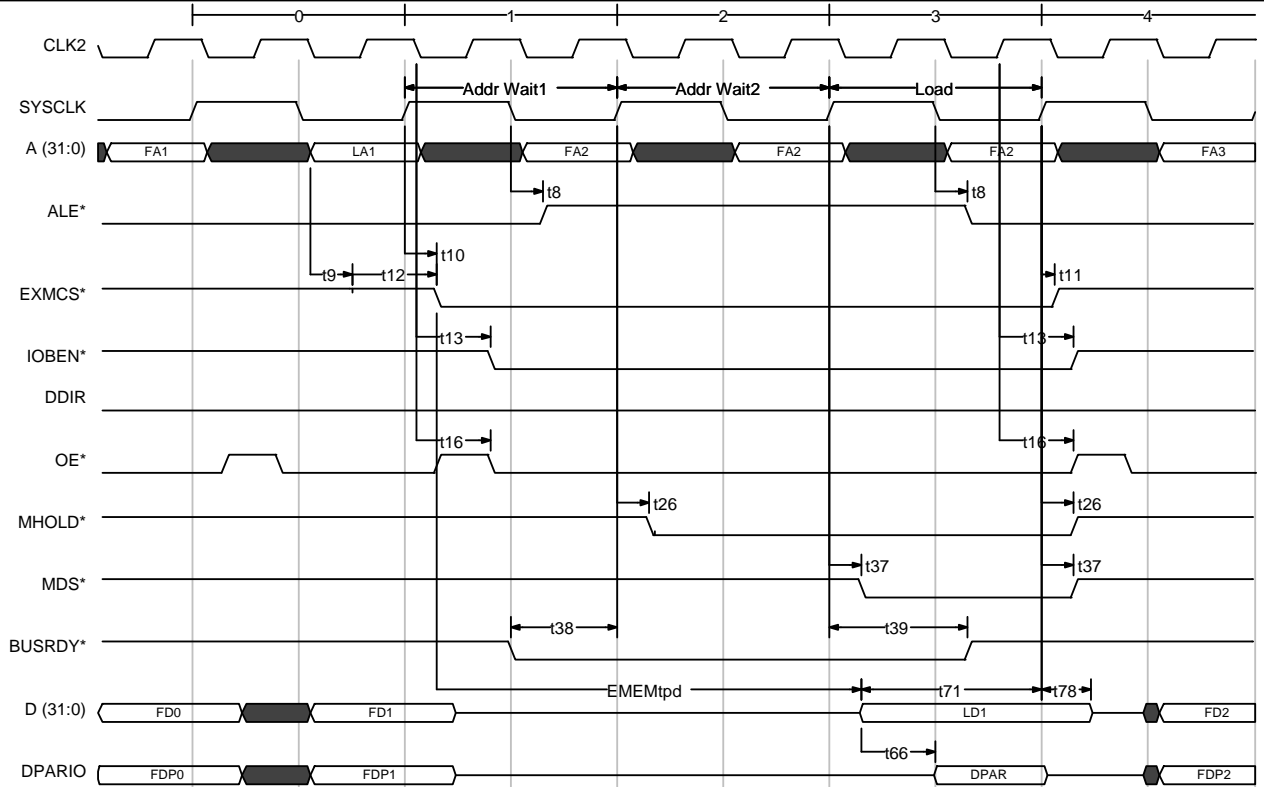

Fig 20) Exchange Memory Load with no Parity or EDAC Protection

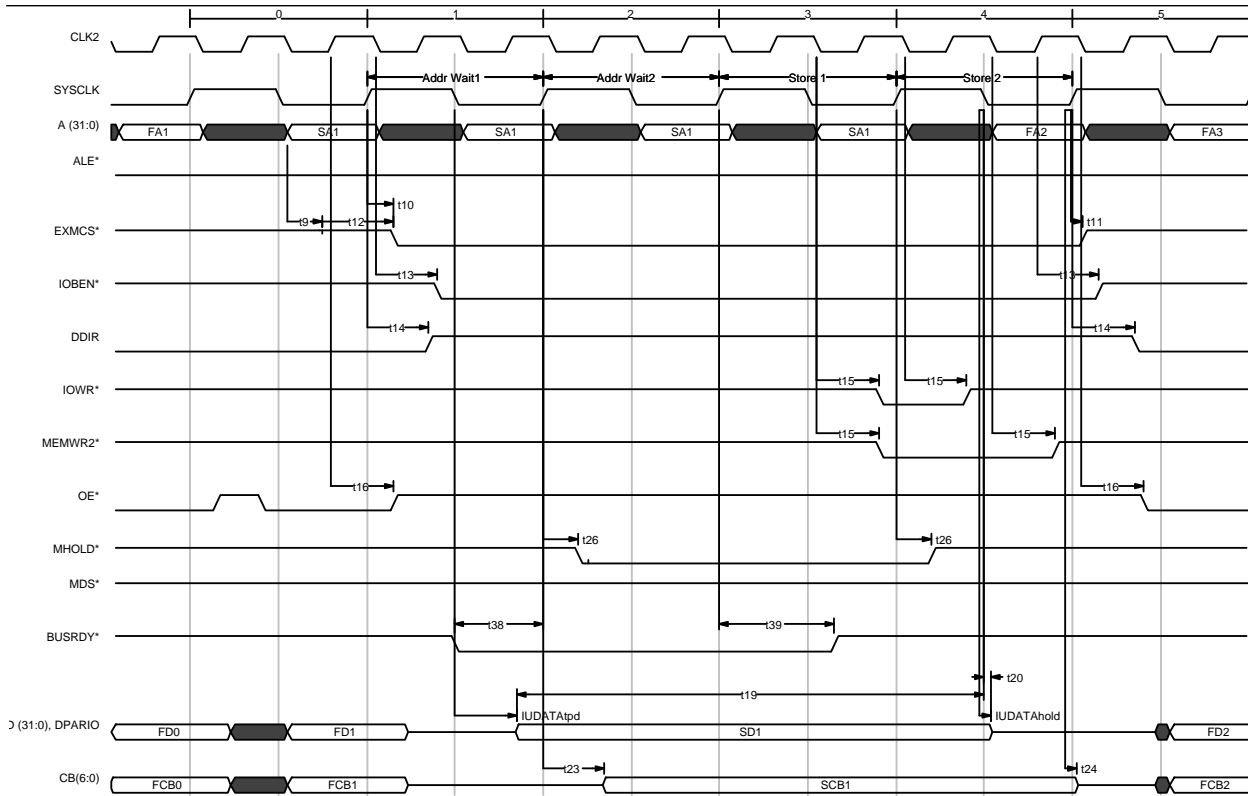

Fig 21) Exchange Memory Store with EDAC and/or Parity Protection

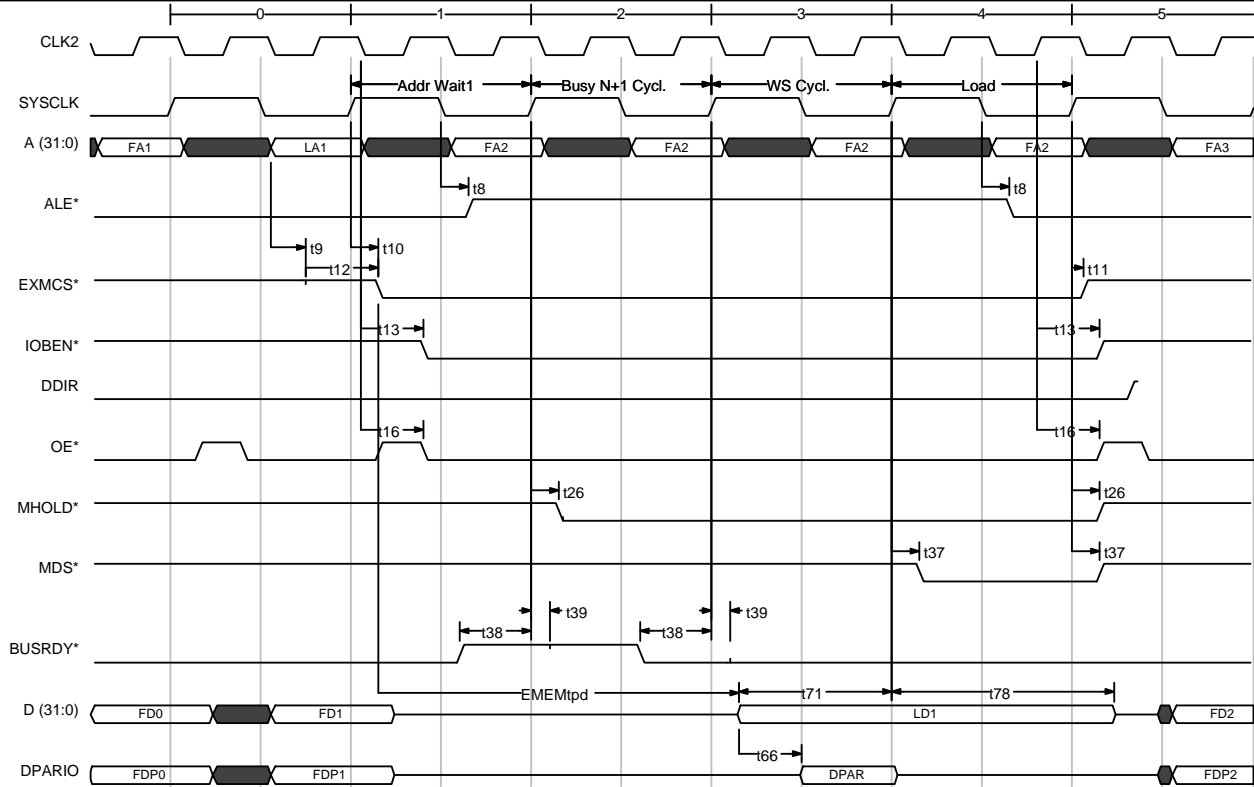

Fig 22) Exchange Memory Load Busy with EDAC and/or Parity Protection

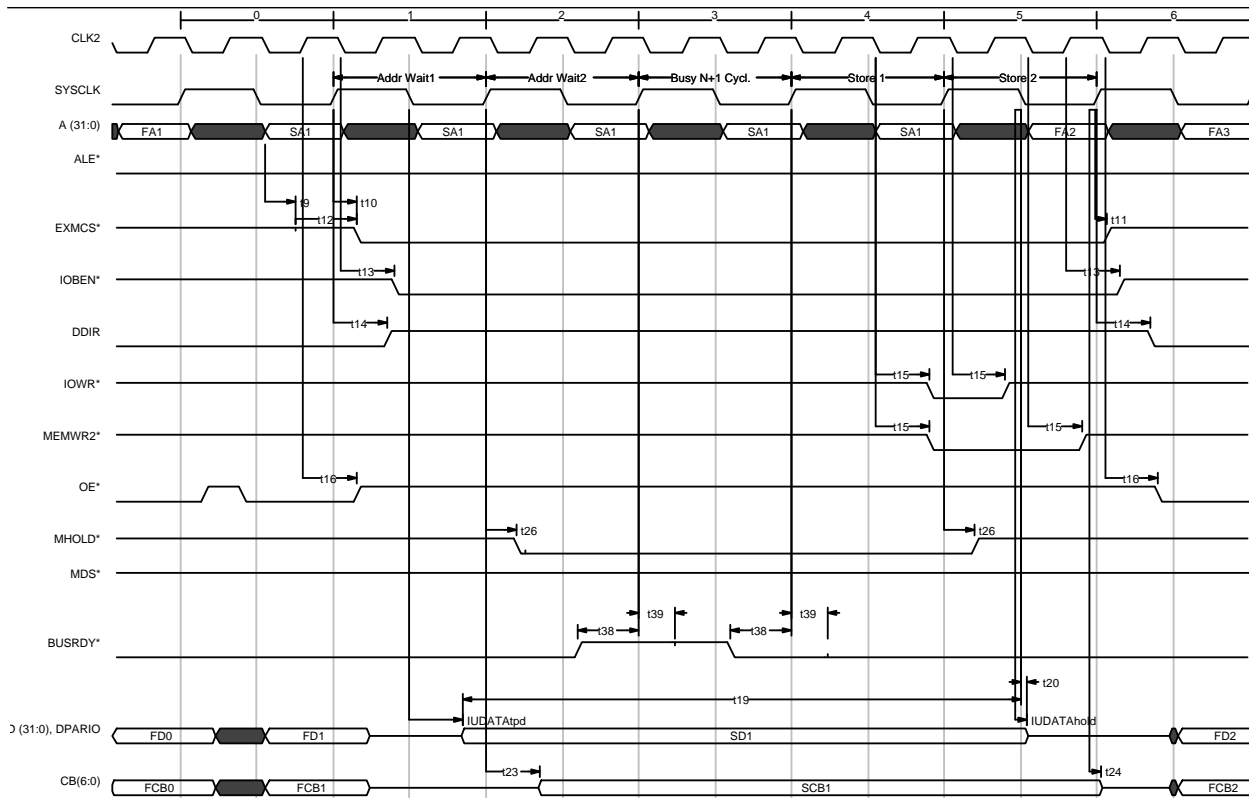

Fig 23) Exchange Memory Store with Busy and with EDAC and/or Parity Protection

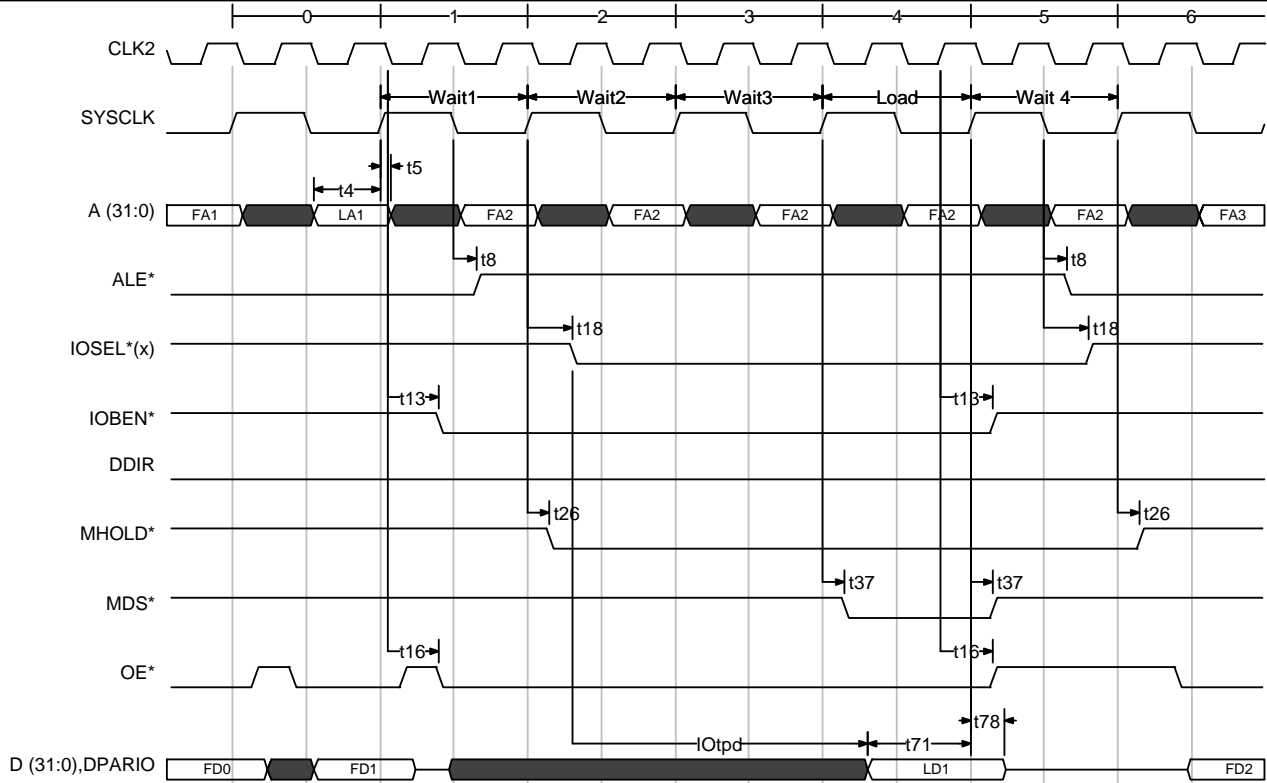

Fig 24) IO Load at 3 waitstates

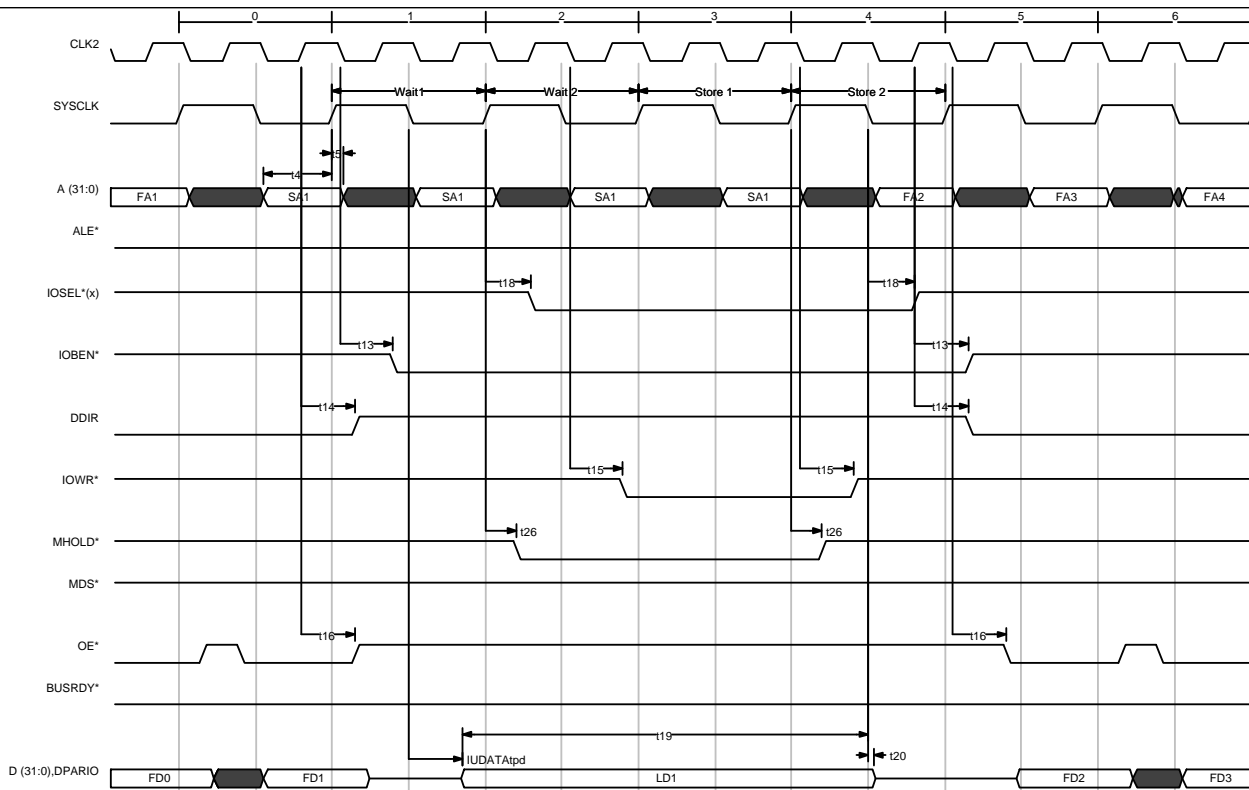

Fig 25) IO Store at 2 waitstates

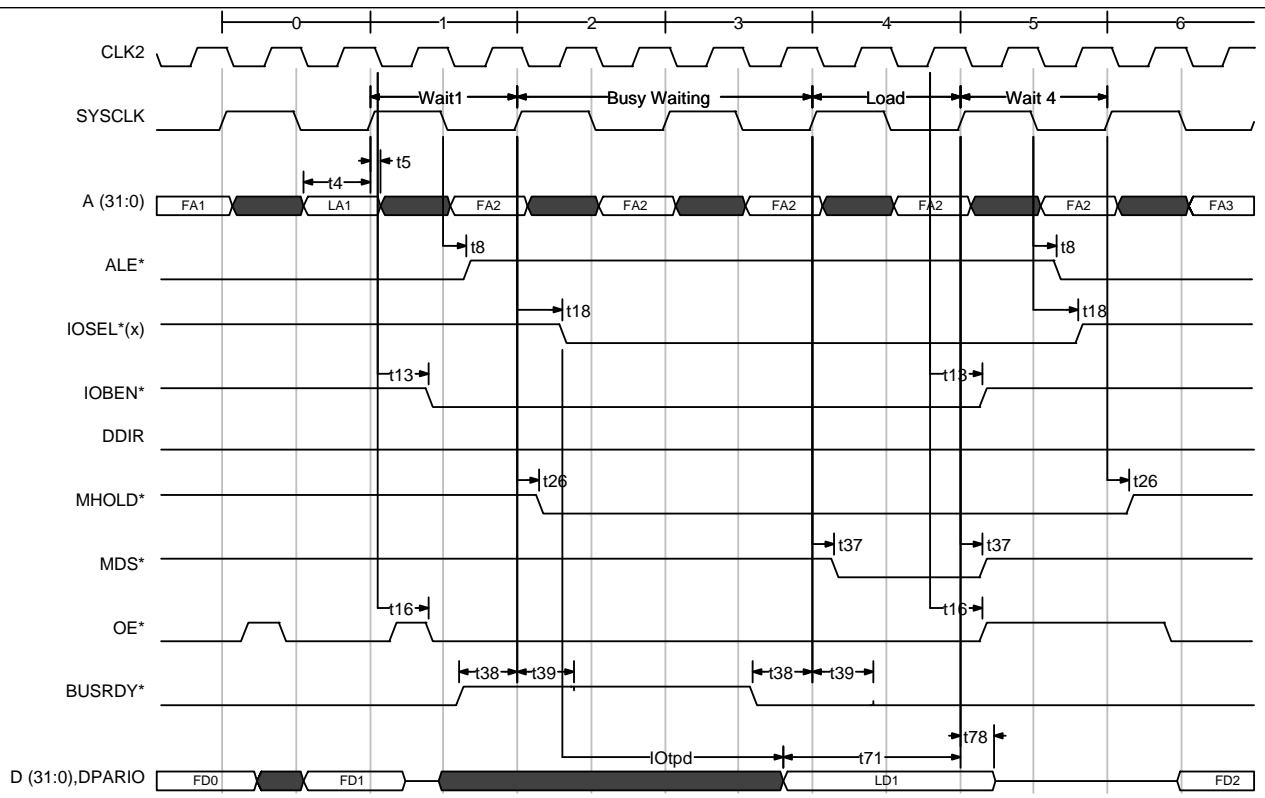

Fig 26) IO Load with Busy

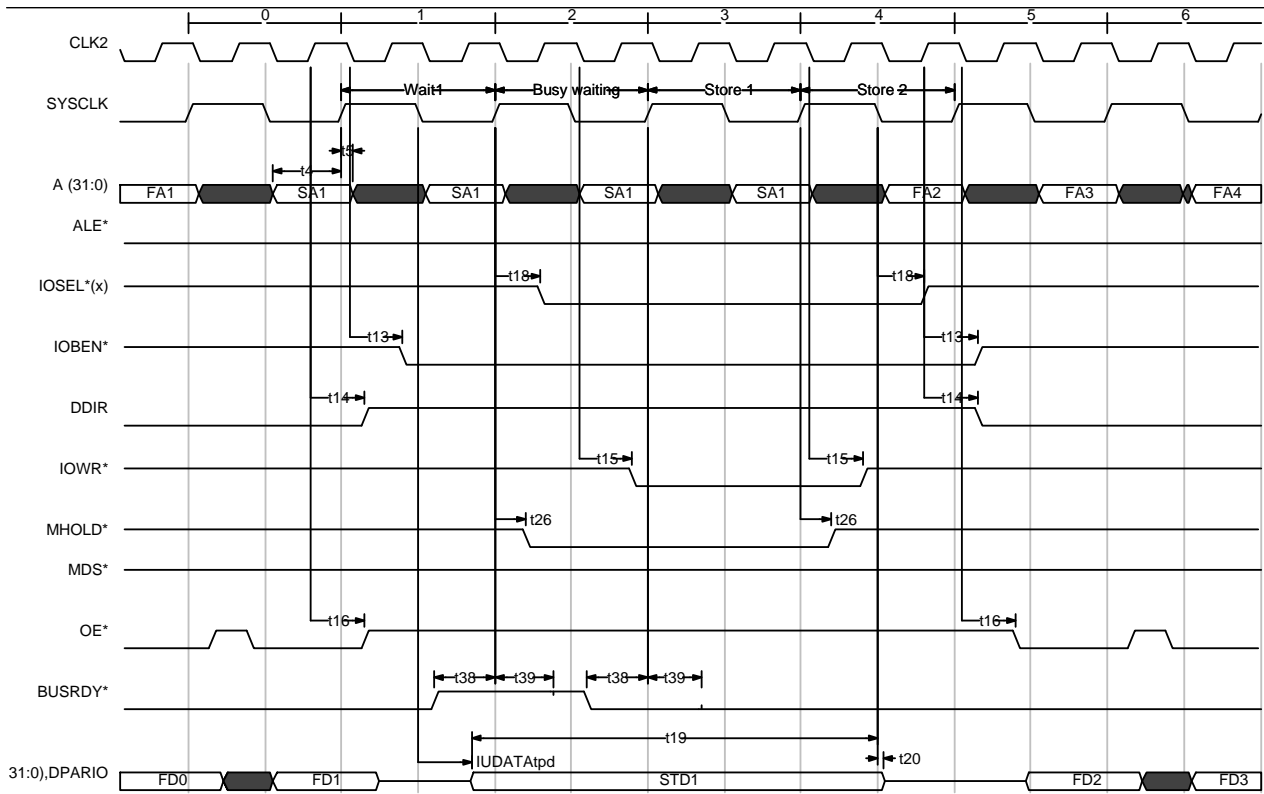

Fig 27) IO Store at 0 waitstates with Busy

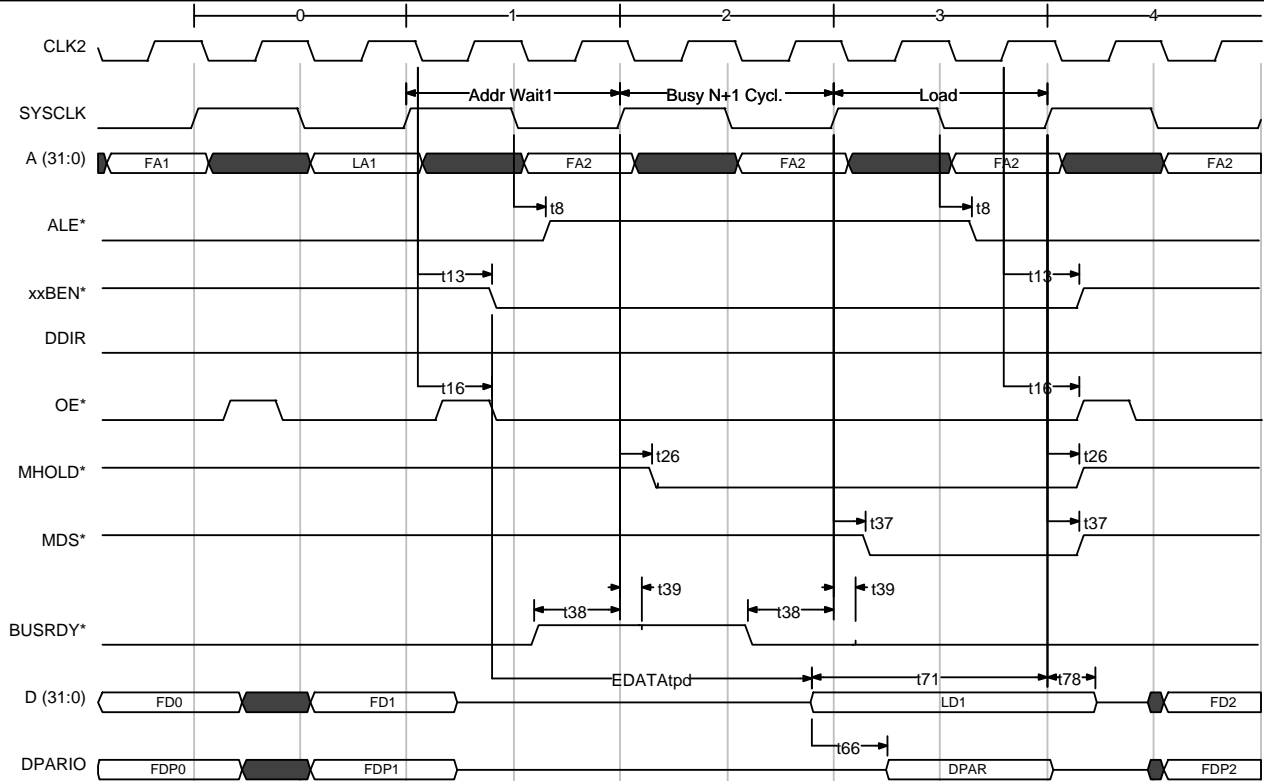

Fig 28) Extended Area Load with Busy

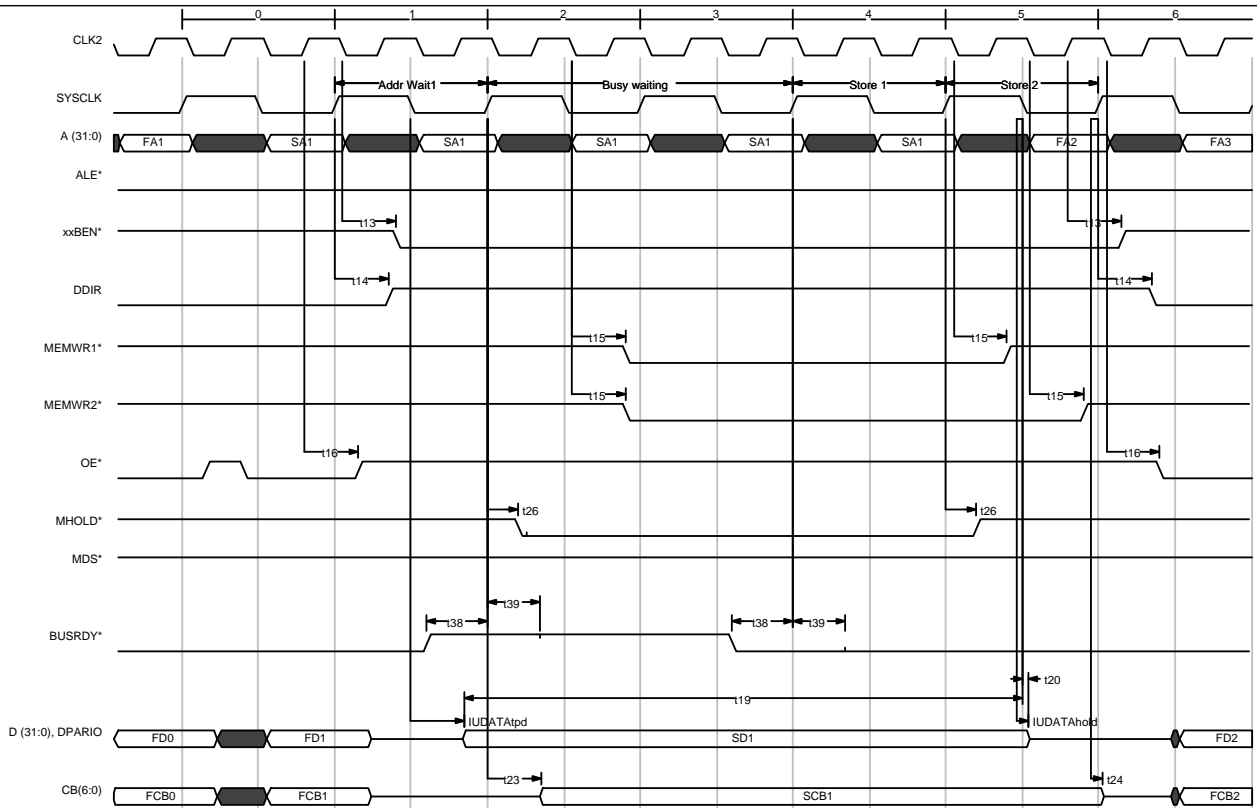

Fig 29) Extended Area Store with Busy

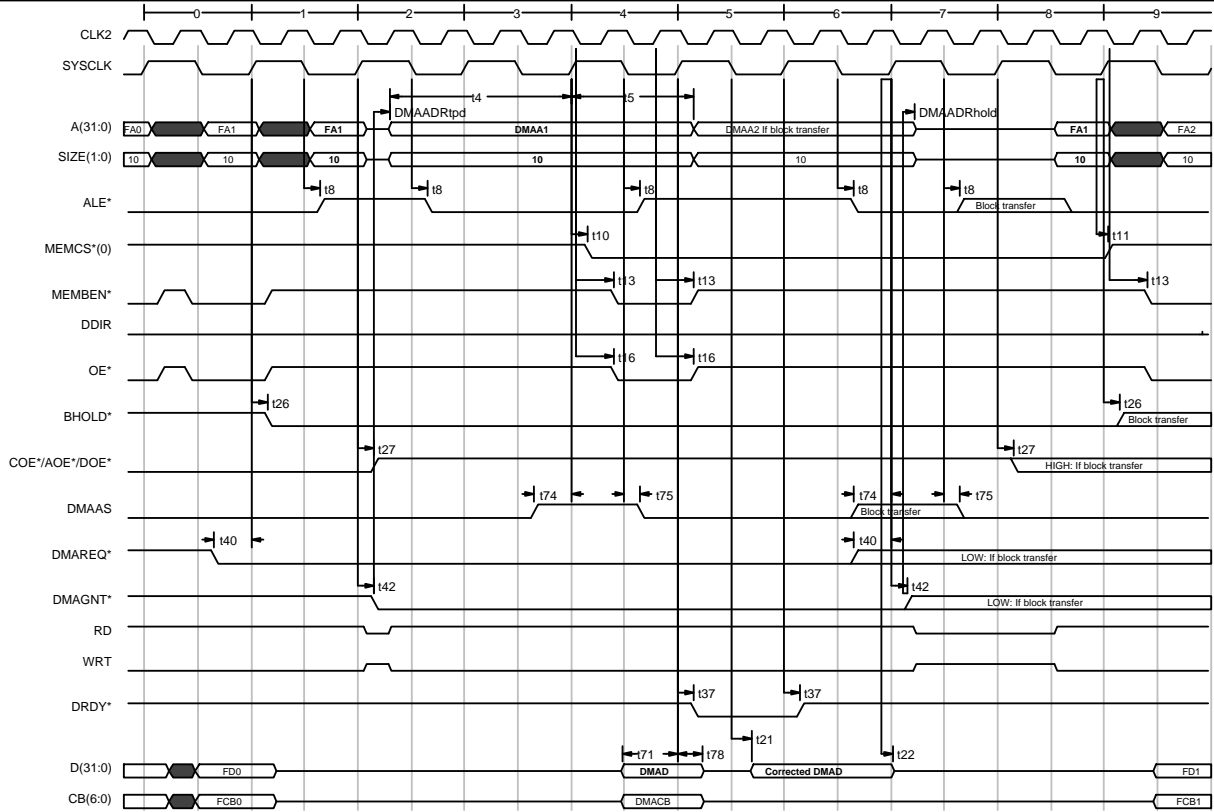

Fig30) DMA RAM Load

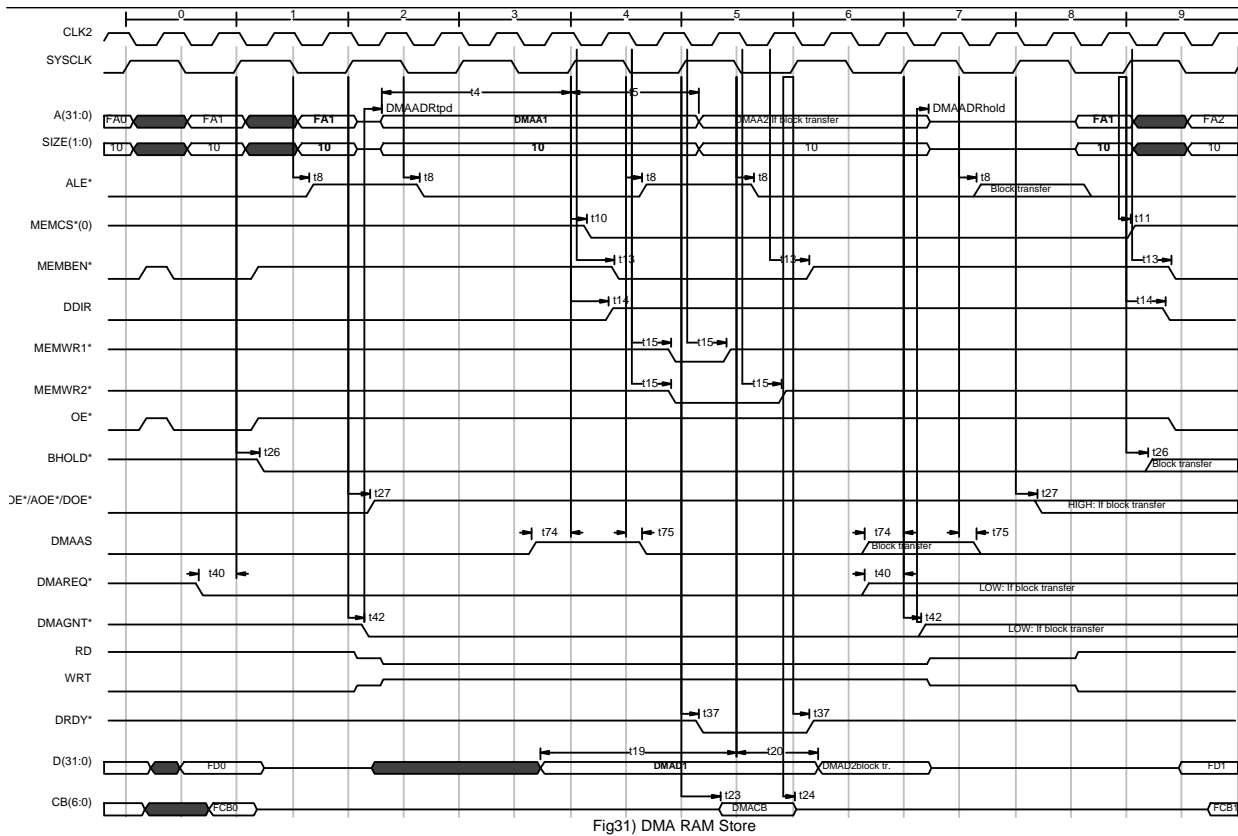

Fig31) DMA RAM Store

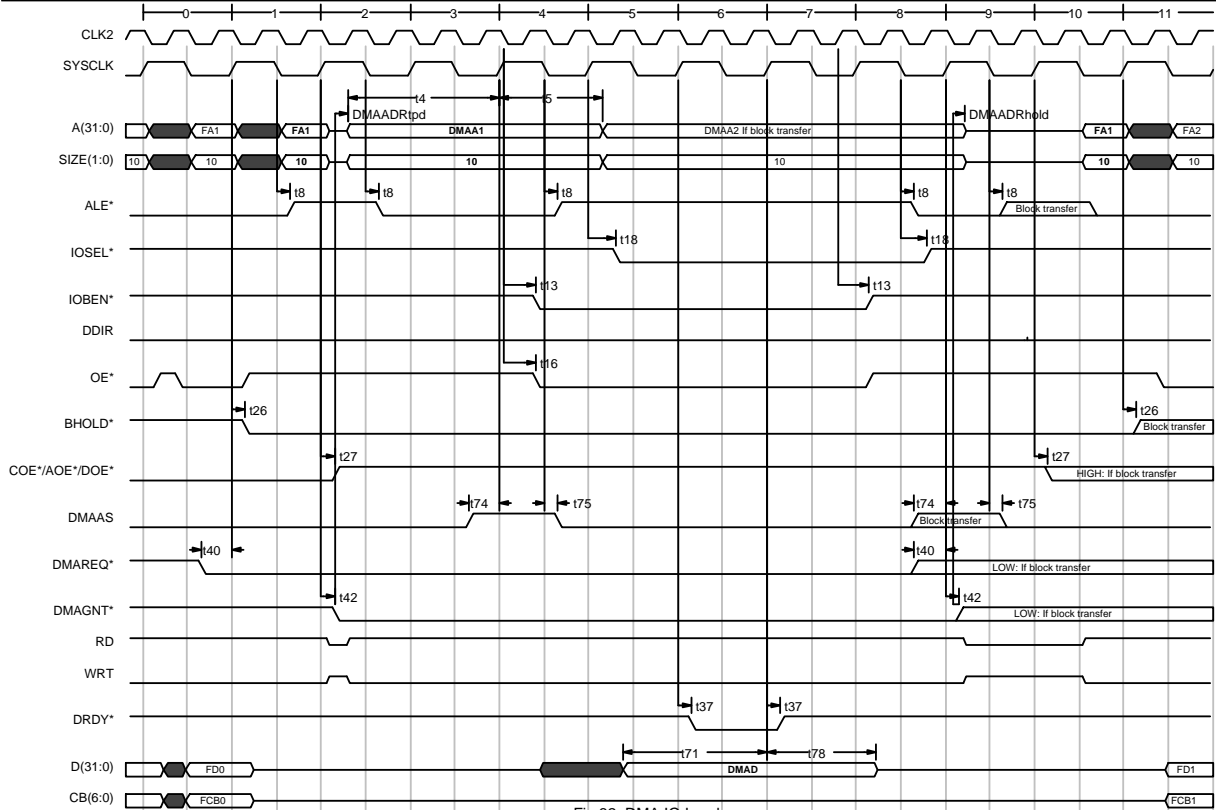

Fig 32: DMA IO Load

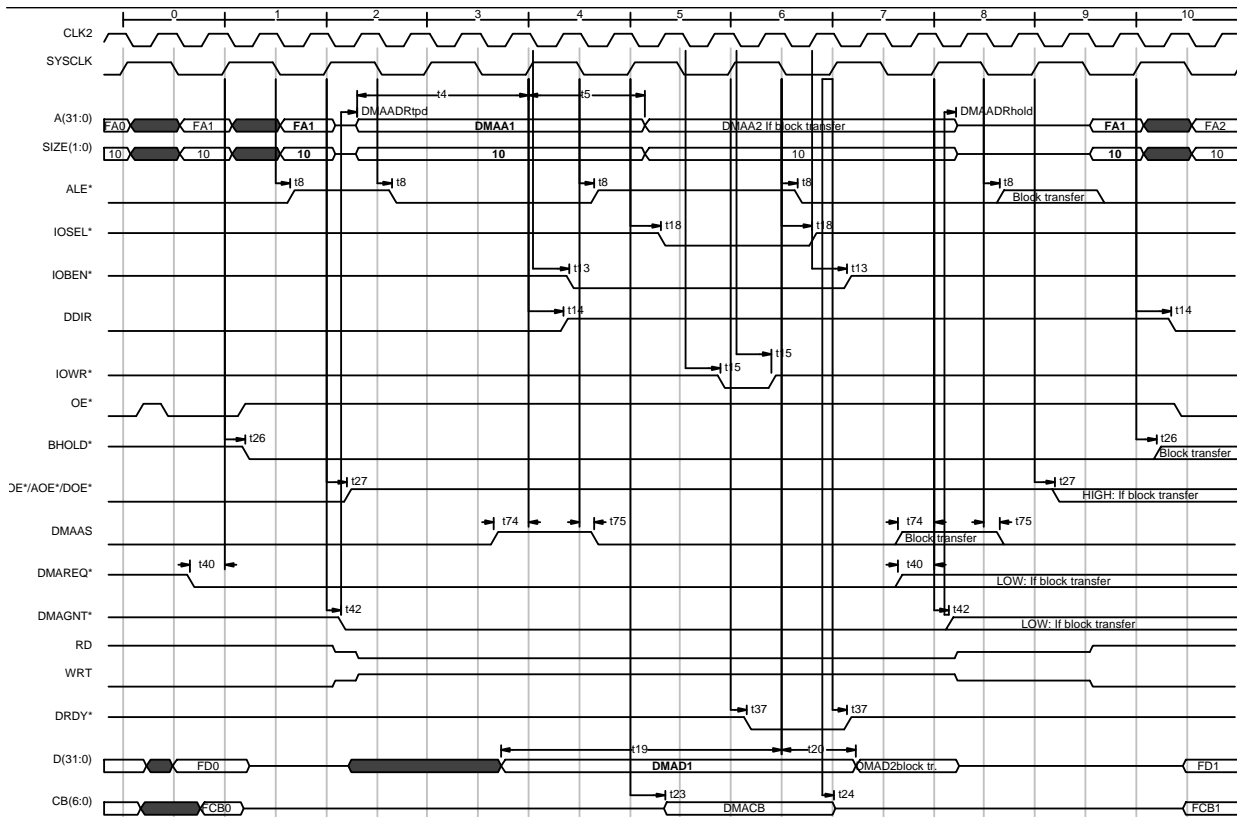

Fig33) DMA IO Store

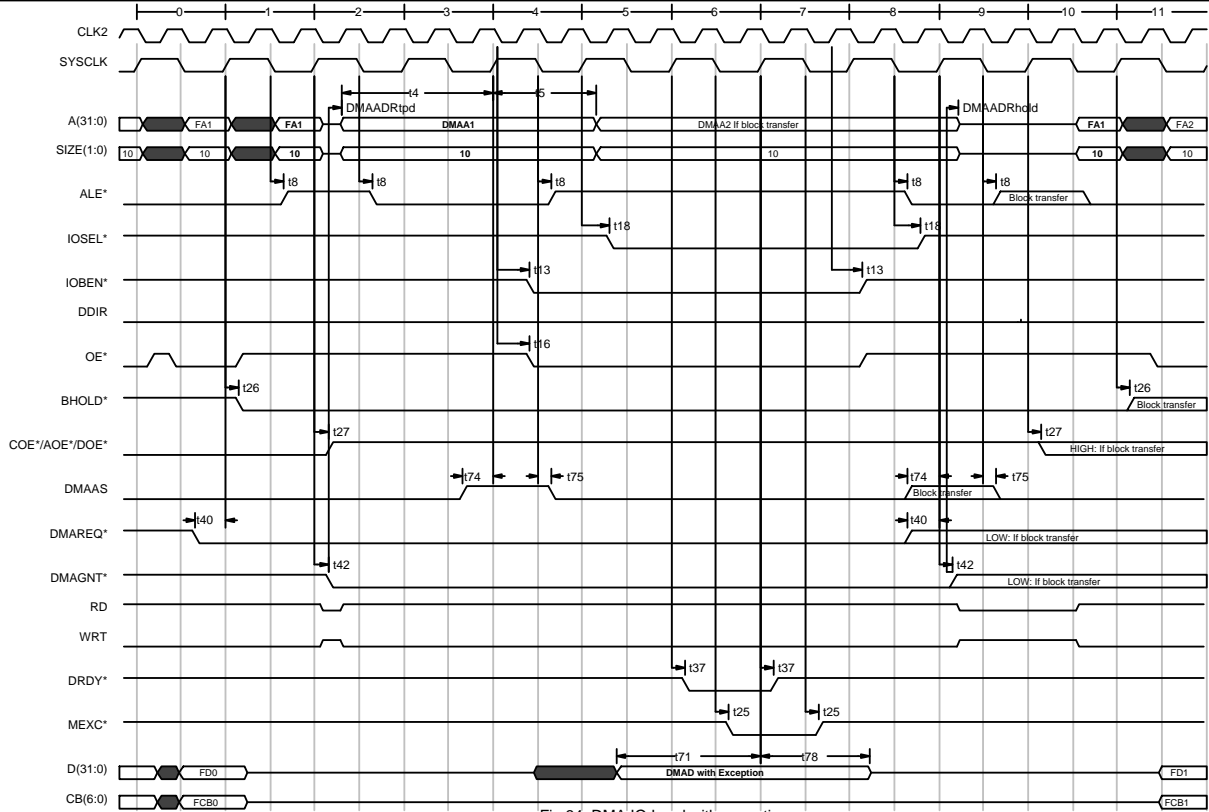

Fig 34: DMA IO Load with exception

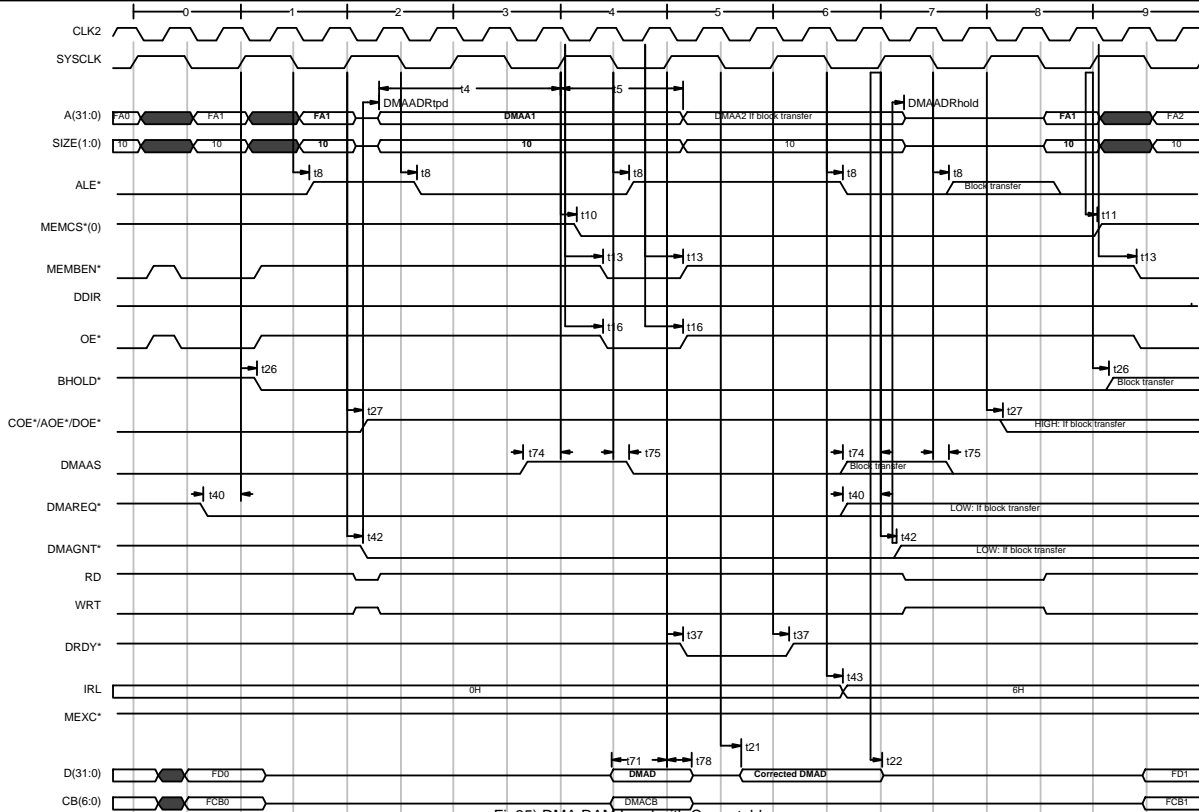

Fig35) DMA RAM Load with Correctable error

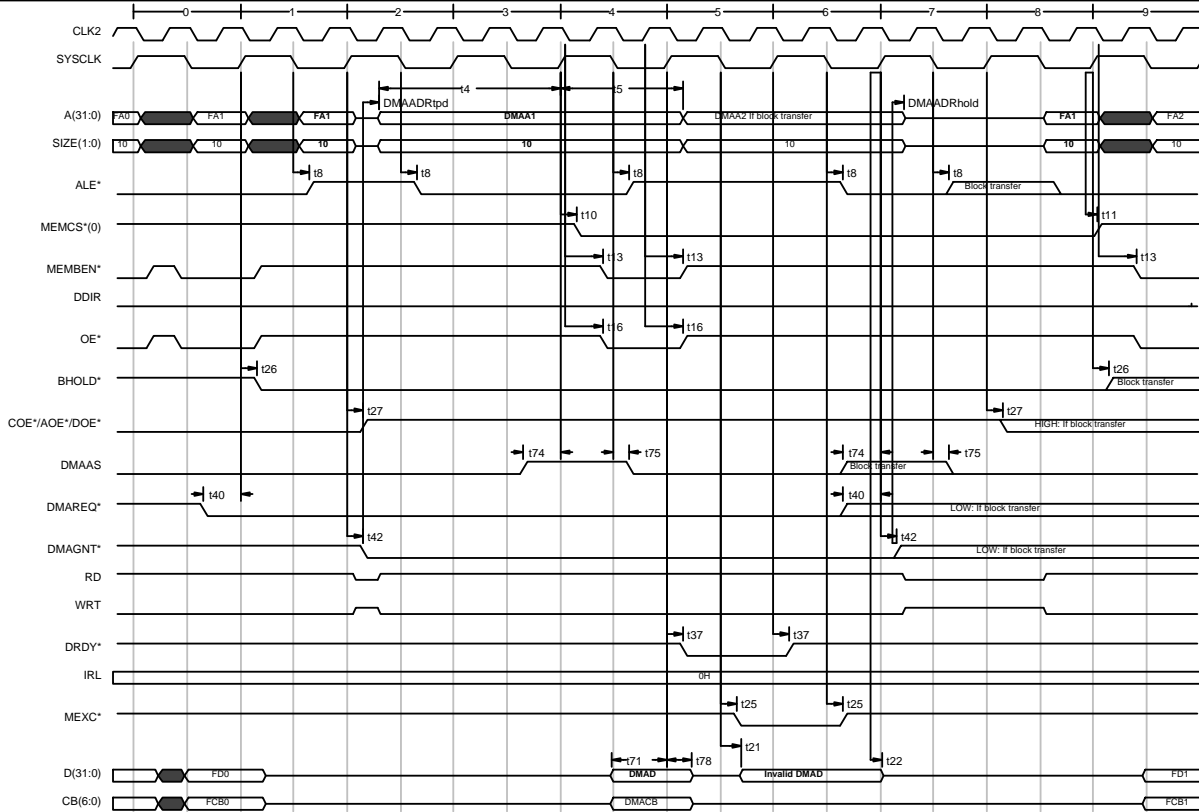

Fig36) DMA RAM Load with Uncorrectable error

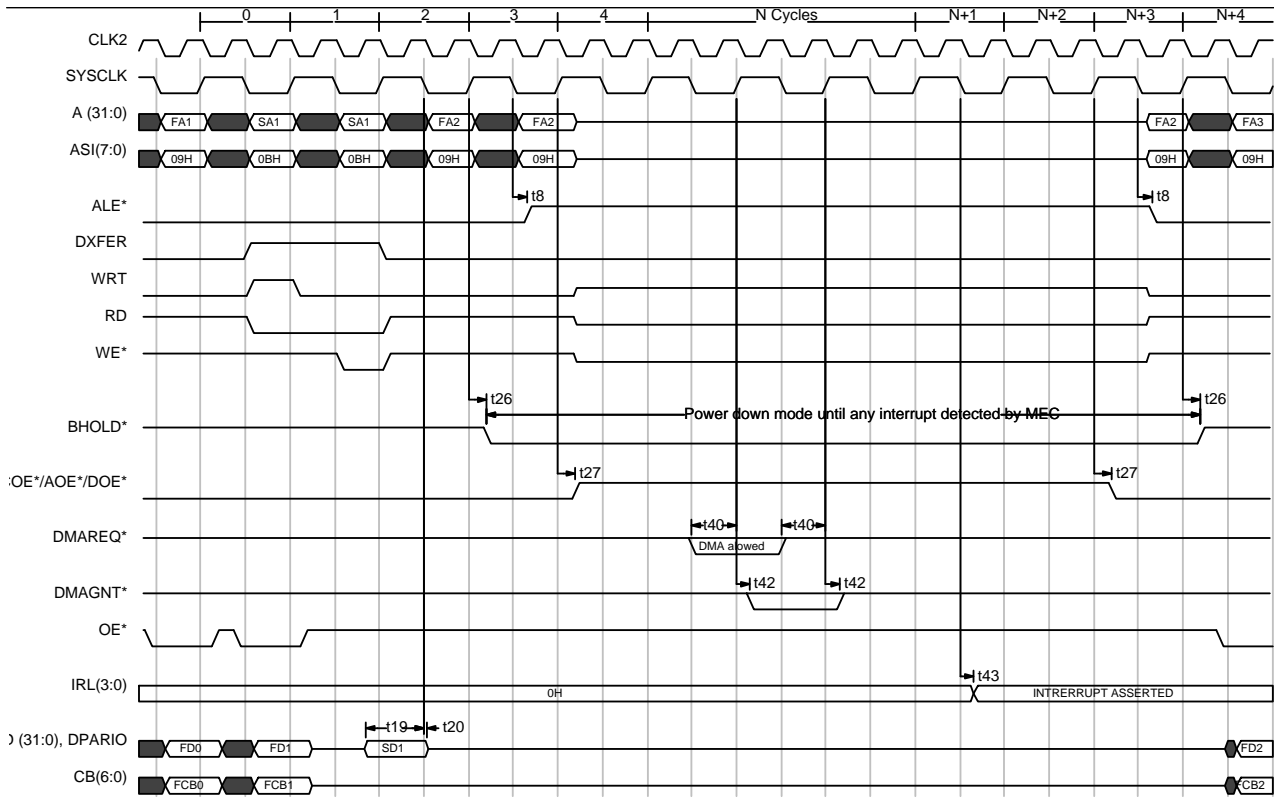

Fig 37) Power down mode after writing to MEC Power Down Register

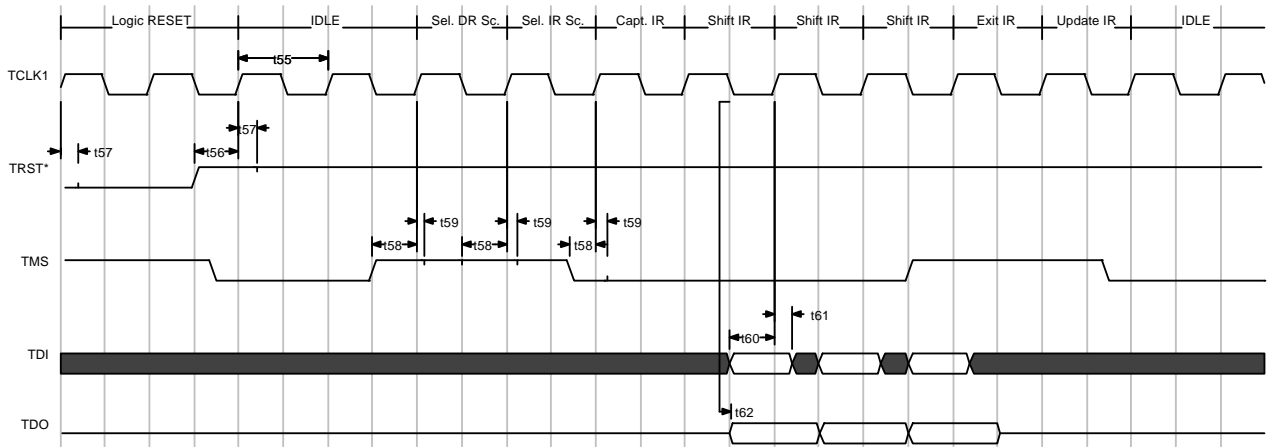

Fig 38) TAP Control Timing

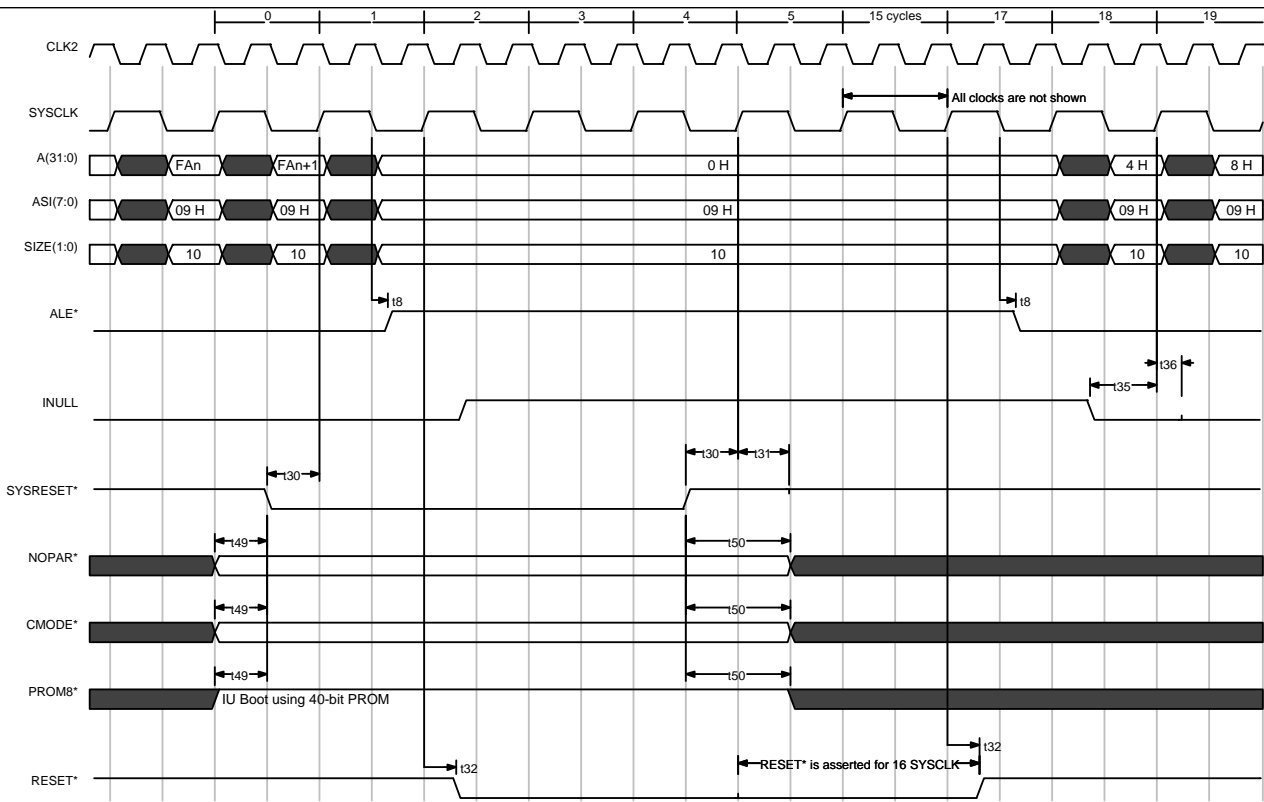

Fig 39) Reset Timing

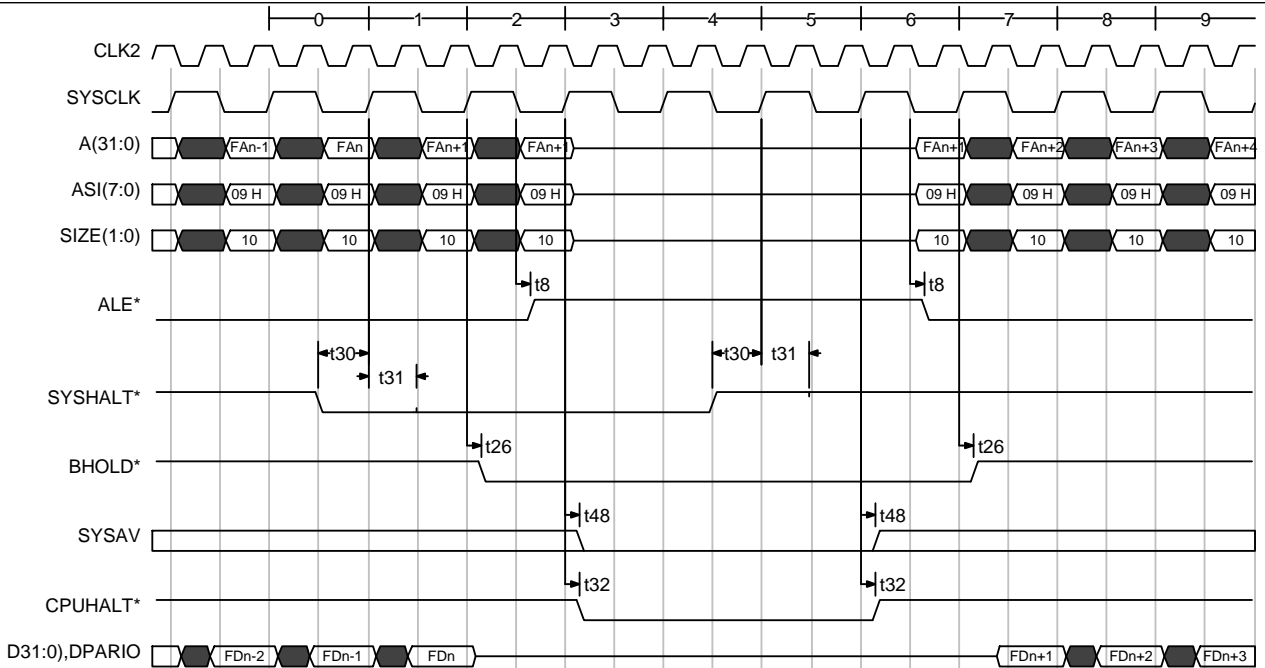

Fig 40) Halt Timing

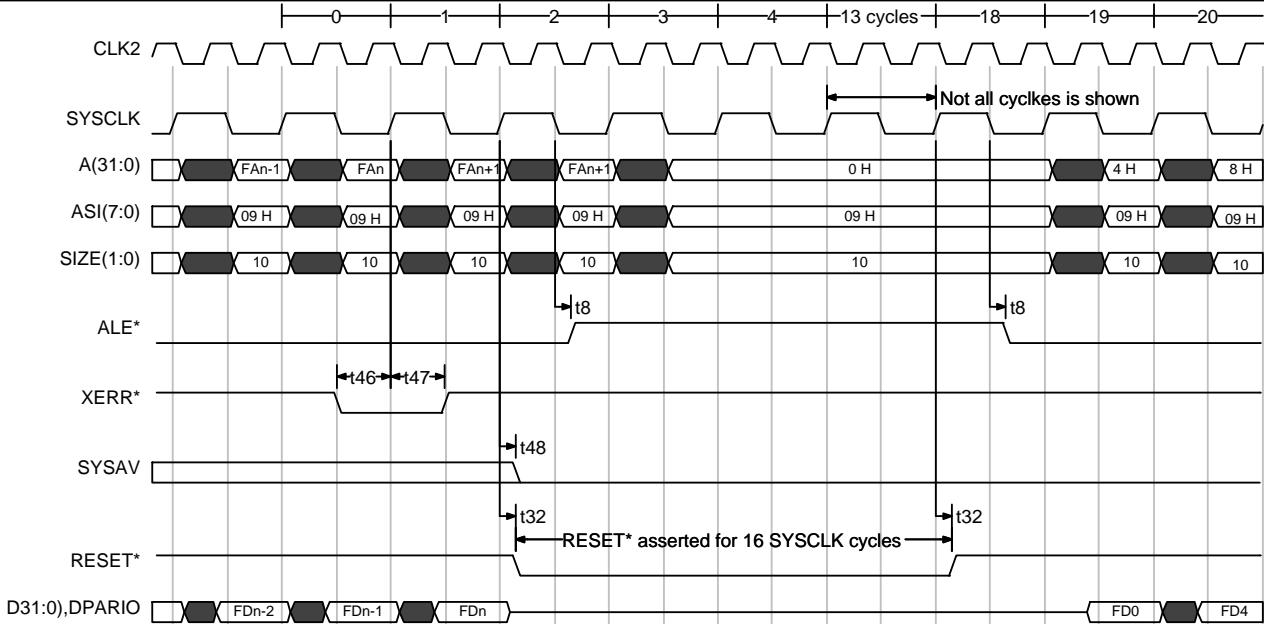

Fig 41) External Error with Reset Timing

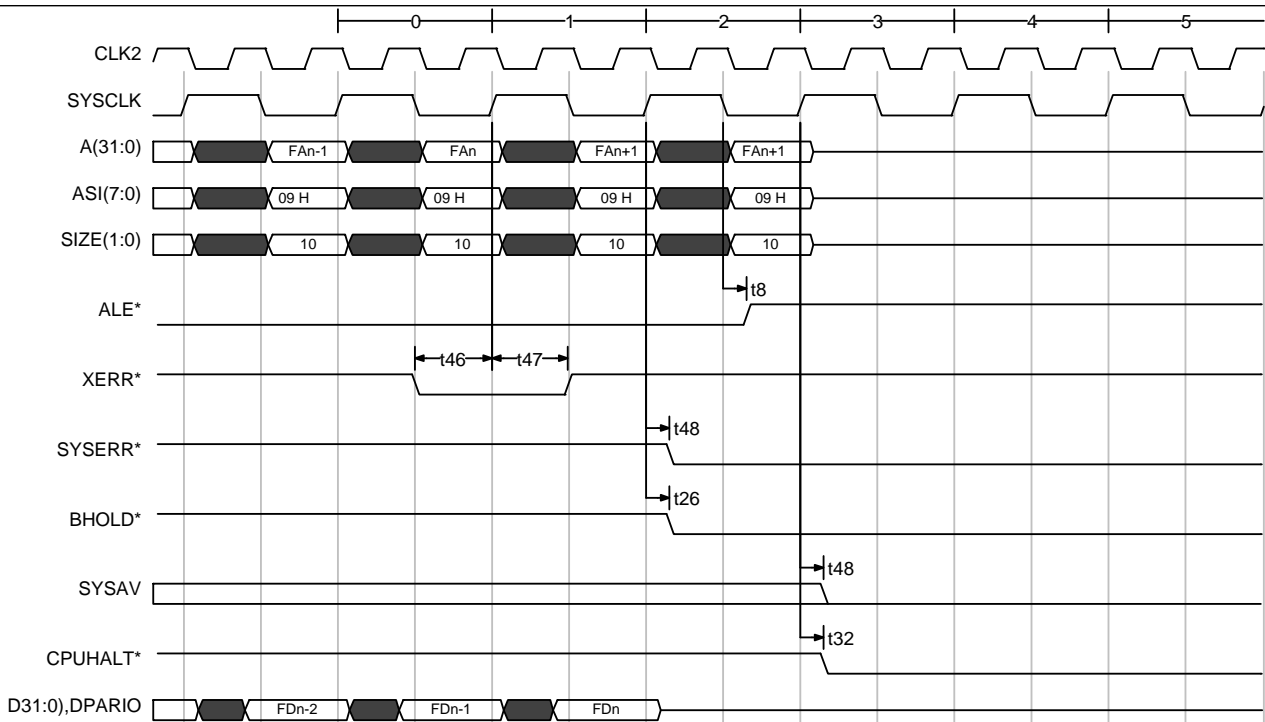

Fig 42) External Error with Halt Timing

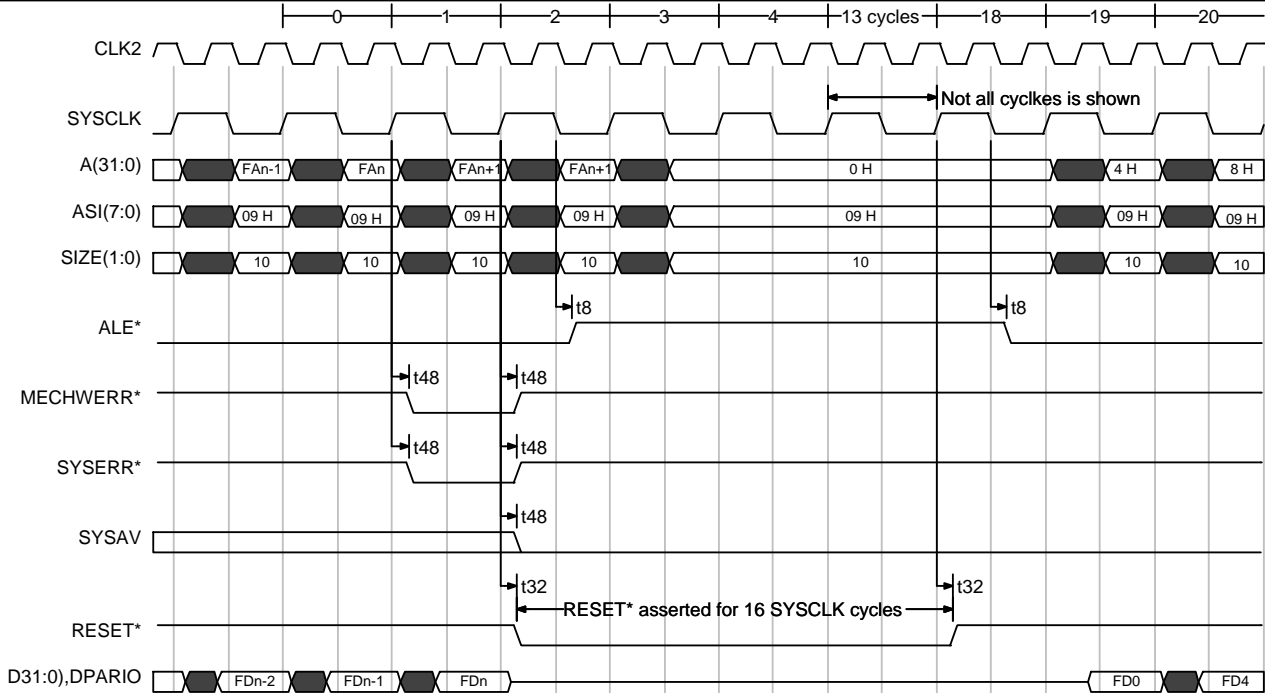

Fig 43) Internal MEC Error with Reset Timing

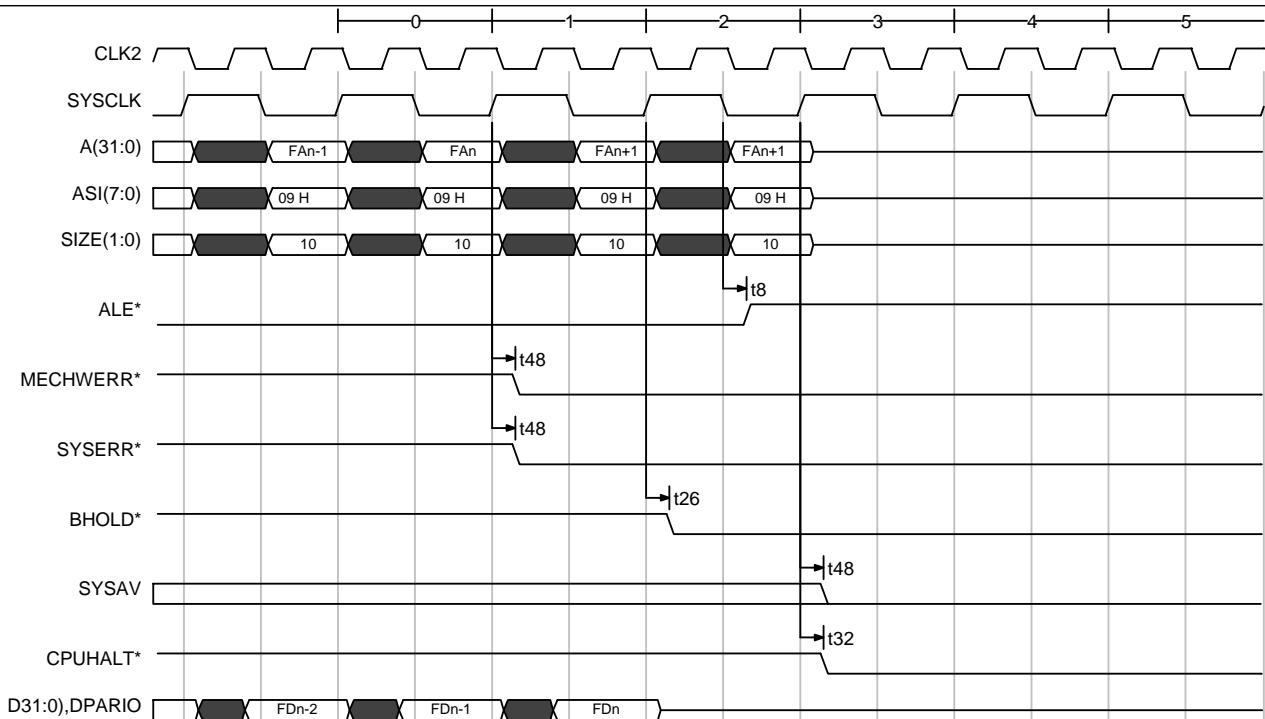

Fig 44) Internal MEC Error with Halt Timing

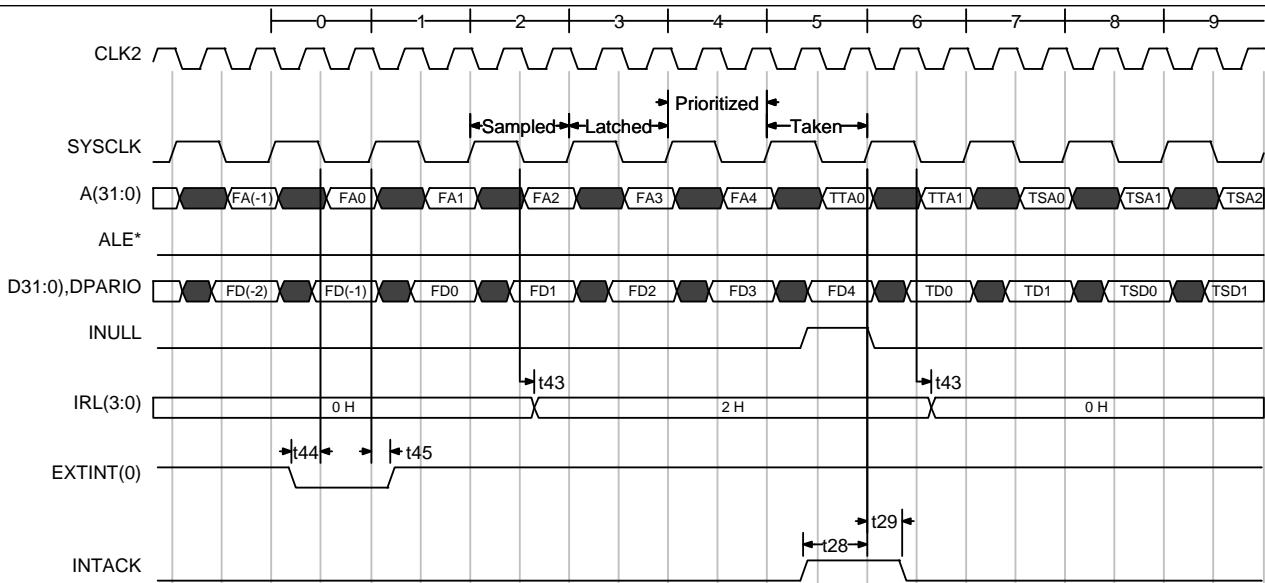

Fig 45) Edge triggered interrupt Timing

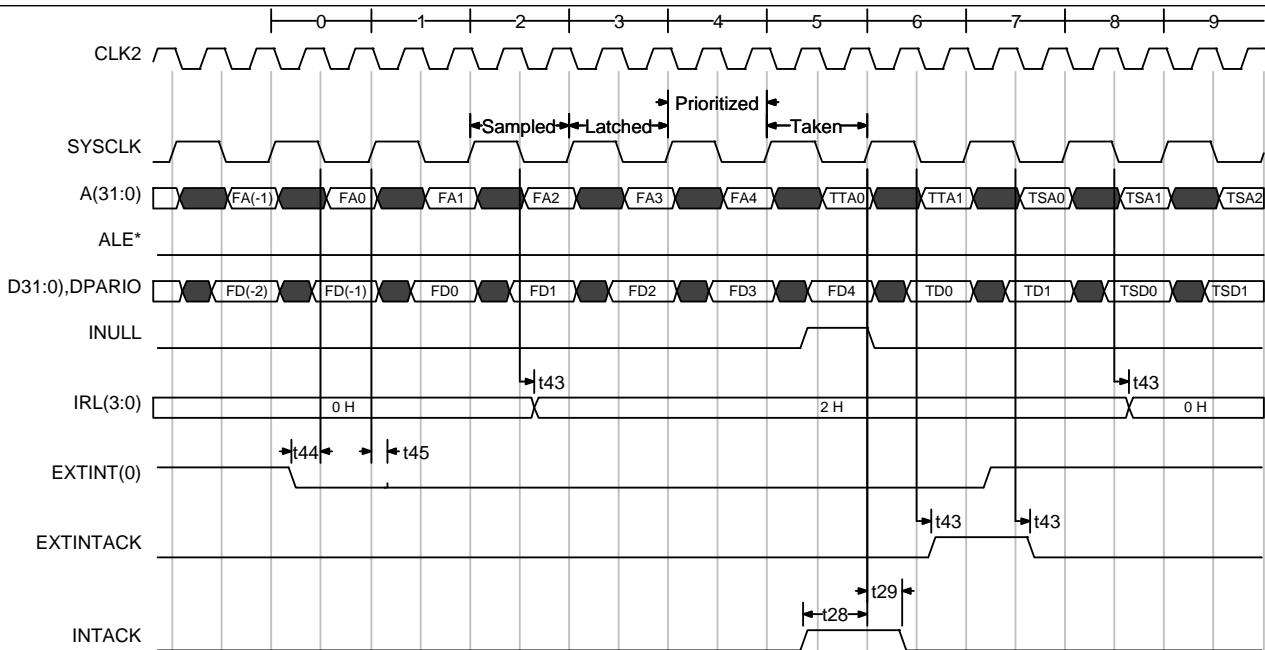

Fig 46) Level triggered interrupt Timing