

TA7318P

WIDE RANGE PEAK POWER METER DRIVER

- Dynamic Range=40dB (Typ.)
- With built-in two channels excellent in matching characteristics for stereo.
- Wide range meter for the 1/4 root compression circuit.
- Single and dual power supply operation.
- Built-in Zener diode providing stable operation to variations in supply voltage (Zener voltage: $\pm 8.5V$)

Unit in mm

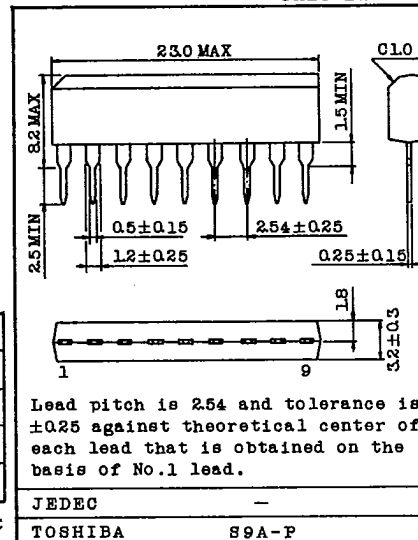

MAXIMUM RATINGS (Ta=25°C)

| CHARACTERISTIC | SYMBOL | RATING | UNIT |
|--------------------------|--------|-----------|------|
| Supply Current | ICC | 20 | mA |
| Power Dissipation (Note) | Pd | 700 | mW |
| Operating Temperature | Topr | -25 ~ 75 | °C |
| Storage Temperature | Tstg | -55 ~ 125 | °C |

Note: Derated above Ta=25°C in the proportion of 7mW/°C

ELECTRICAL CHARACTERISTICS

(VCC-V_{EE}=±25V, Ta=25°C, f=1kHz)

| CHARACTERISTIC | SYMBOL | TEST CIRCUIT | TEST CONDITION | MIN. | TYP. | MAX. | UNIT |
|------------------------------|------------------------|--------------|---|------|------|------|------|
| Quiescent Current | ICCQ | 1 | I _{IN} =0, V ₉ =7V, V ₅ =-7V | - | 2.1 | 3.0 | mA |
| Quiescent Output Current | IOQ | 1 | Input short | - | - | 1 | μA |
| Channel Balance | CH.B | 1 | I _{IN} =-100μA | - | - | 1.4 | dB |
| Input-Resistance | RIN | 1 | - | - | 2 | - | kΩ |
| Channel Separation | I _{OUT} (sep) | 1 | I _{IN} =-1mA | - | -60 | - | dB |
| Output Current | I _{OUT} | 1 | I _{IN} =-100μA | 1.6 | 2.1 | 2.6 | mA |
| Min. Input Current | I _{IN} (Min) | 1 | - | - | 7 | - | μA |
| Max. Input Current | I _{IN} (Max) | 1 | - | - | - | 2 | mA |
| Hold Terminal Voltage (Note) | V _H | 2 | Input short | 25 | - | 150 | mV |

The hold terminal voltage is classified into two ranks as follows:
 V_H-1 : 25~65mV, V_H-2 : 45~150mV

EQUIVALENT BLOCK DIAGRAM

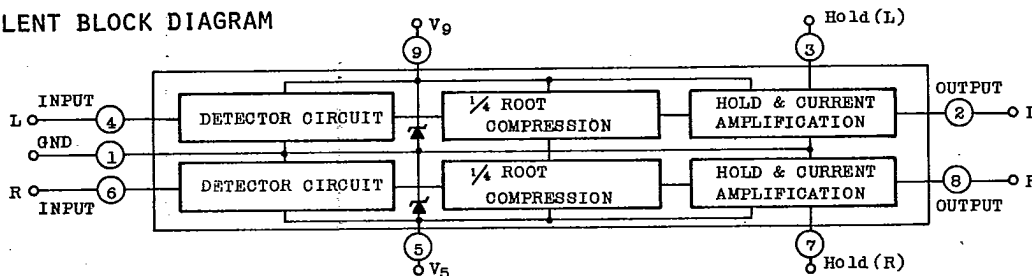

TOSHIBA

TA7318P

TEST CIRCUIT 1.

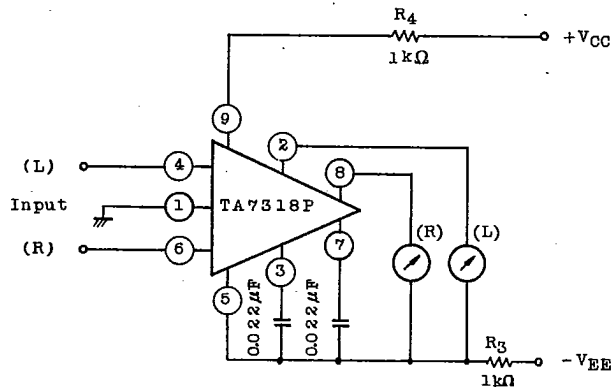

TEST CIRCUIT 2.

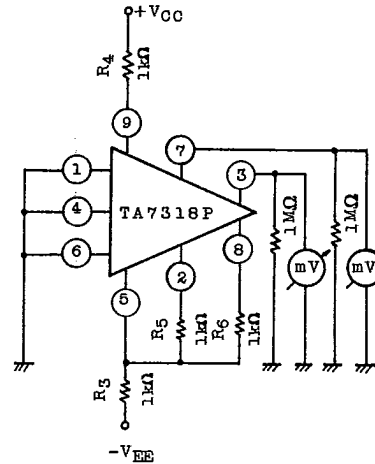

APPLICATION CIRCUIT

1. APPLICATION TO POWER METER

(Use of Dual-power supply)

2. USE OF SINGLE POWER SUPPLY

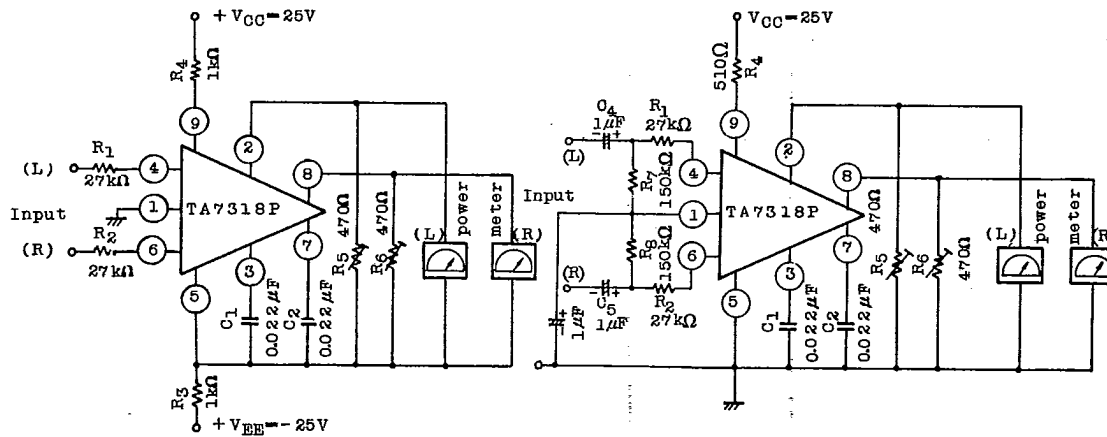

Power meter

Sensitivity: 1.1mA

Impedance: 1.5kΩ

C₁, C₂: Mylar film capacitor is used.

(Note) In case of using single power supply, the meter deflects the current charged to C₁ and C₂ at power ON.

AUDIO LINEAR IC

TA7318P

APPLICATION

Method of deciding each constant

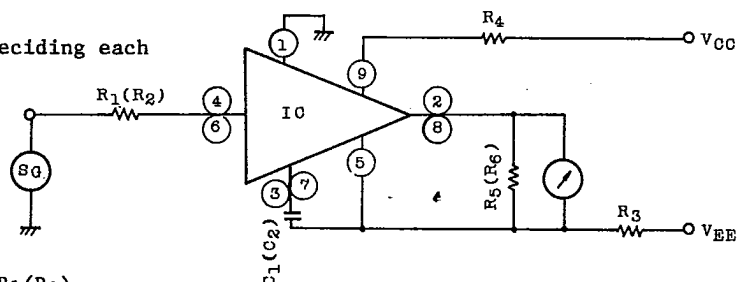

1. DECISION OF $R_1(R_2)$

$R_1(R_2)$ is a resistance that decides input current, by which the IC input is decided to be about 1mA. For example, when full scale is 100W, if $R_L = 8\Omega$ load, $R_1(R_2)$ is expressed as follows:

$$P_{OUT} = \frac{V^2 (V.rms)}{R_L (8\Omega)} \quad V = \sqrt{P \times R_L} = \sqrt{100 \times 8} = 28.28V_{rms}$$

$$V_{IN} = 1mA \times R_1(R_2) = 28.28V$$

$$R_1(R_2) = 28.28k\Omega \quad \dots\dots 27k\Omega \text{ is used for } R_1(R_2)$$

2. DECISION OF $R_5(R_6)$

$R_5(R_6)$ is a shunt resistance that decides angle of a meter, by which the meter is adjusted so as to become full scale when the IC input is 1mA.

For example, when 1mA enters the input, the output is about 4mA. (Refer to $I_{IN} - I_{OUT}$ characteristics shown in the attached sheet.) Therefore, if a meter of 1mA in meter sensitivity and 680 Ω in internal impedance is used, the following equation is expressed:

$$R_5(R_6) = \frac{680}{3} = 226.7 \div 220\Omega$$

Since $R_5(R_6)$ has meter variations, the use of variable resistance enables right and left adjustments to be made more easily.

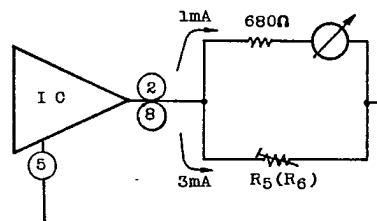

TA7318P

3. DECISION OF $R_3(R_4)$

$R_3(R_4)$ is a resistance that decides supply current, by which pin 9 and pin 5 are fixed to GND (Pin 1) at $\pm 8.5V$ respectively. Therefore, the value of $R_3(R_4)$ should be decided so that the current flown into IC by supply voltage may become $10mA \sim 20mA$.

For example, when $R_3(R_4)$ is used at $V_{CC} = 25V$ and $V_{EE} = -25V$, if it has 10% supply voltage variation, the following equation is obtained:

$$R_3(R_4) \geq \frac{25 \times 1.1 - 8.5V}{20mA} \text{ k}\Omega = 0.95\text{k}\Omega$$

If $R_3(R_4)$ is $1k\Omega$, the supply current becomes $19mA$.

In this case, if $R_3(R_4)$ is $1.2k\Omega$ by taking the power and variation into consideration, the supply current is expressed as follows:

$$I = \frac{25 - 8.5}{1.2k\Omega} = 13.8mA$$

Since $P = I^2R = 13.8^2mA \times 1.2k\Omega \doteq 230mW$, the resistance of $1/4W$ type is sufficient. (Refer to I_{CC} - I_{OUT} shown in the data sheet.)

4. DECISION OF $C_1(C_2)$

$C_1(C_2)$ is a capacity that decides the recovery time of a meter. A capacitor to be used should be lower in variation; for example, it is recommended that mylar film capacitor be used. The capacitor is classified into two ranks according to recovery time variations.

The typical values are shown as follows: (The recovery time from $0dB \rightarrow -40dB$ is about. $2 \sim 4sec.$)

| Classification | $C_1(C_2)$ |
|----------------|---------------|
| TA7318P-1 | $0.0068\mu F$ |
| TA7318P-2 | $0.022\mu F$ |

(Refer to $C_1(C_2)$ -TRECA shown in the data sheet.)

TA7318P

5. PRECAUTIONS AT TURN OF METER SENSITIVITY

When the signal source impedance R_1 (R_2) is remarkably changed, the variations in amplification at the time of small input to the meter are apt to generate; therefore, these variations must be attenuated without changing the impedance.

In this case, however, $r < R_1$ (R_2).

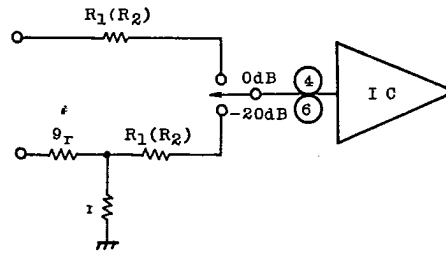

6. CONNECTION OF R_1 AND R_7 TO CIRCUIT WHICH RELAY IS USED FOR OUTPUT TERMINAL

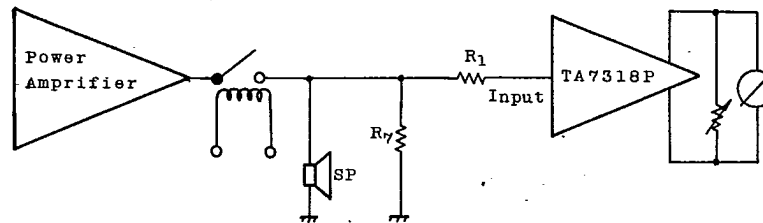

The resistance (R_7) should be inserted between input and ground as shown in the above figure. This is because the resistance prevents the occurrence of such a phenomenon as, as long as the relay is turned OFF, the input impedance of TA7318P becomes high to be liable to receive the surrounding noise.

It is recommended that R_1 and R_7 be arranged close to the IC as far as possible.

TA7318P

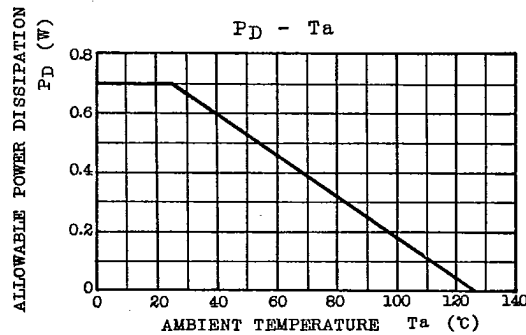
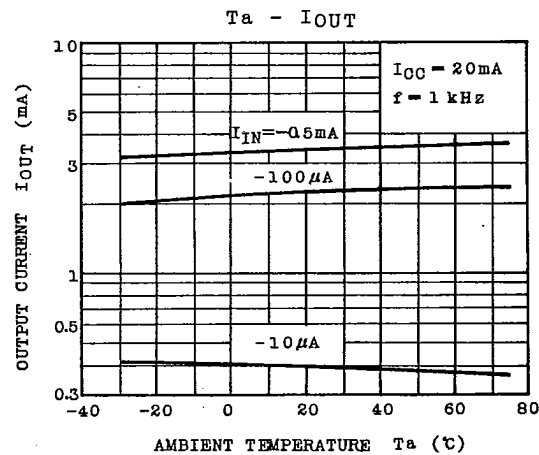
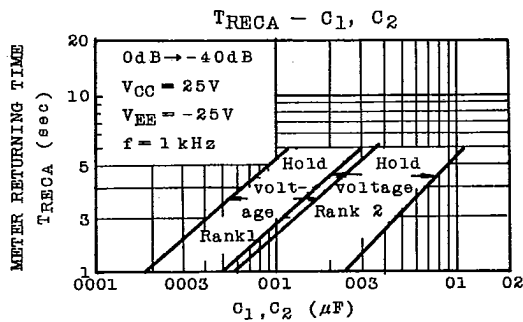
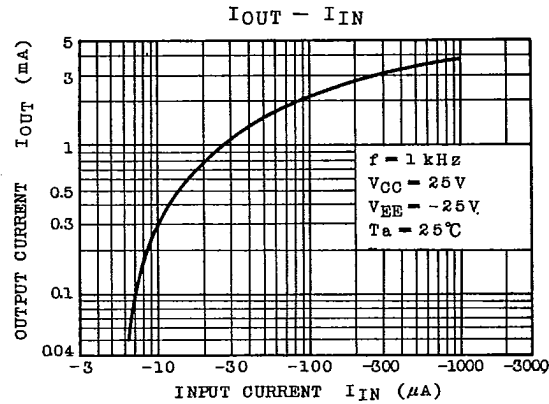
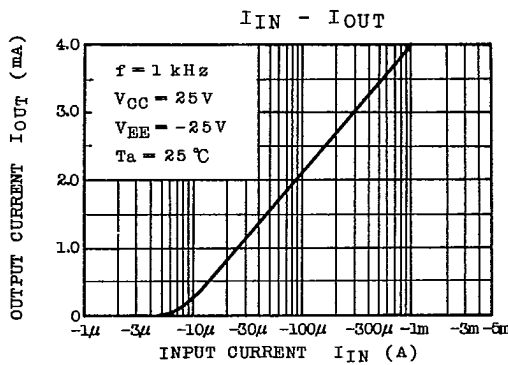
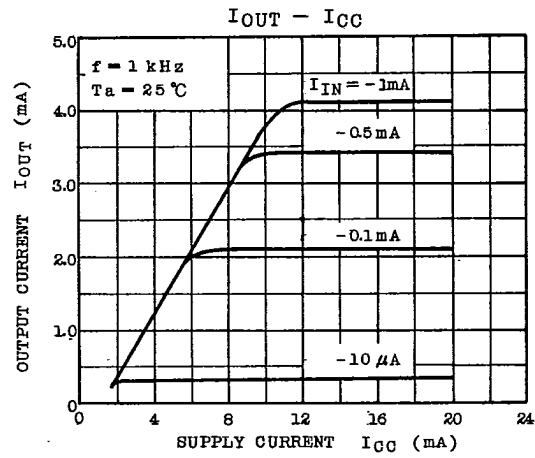
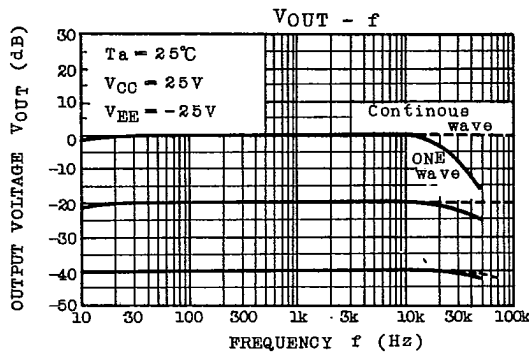

AUDIO LINEAR IC