

TA7358APG

FM Front-End

The TA7358APG is designed for a FM front-end application, which is suitable to a portable radio or a radio cassette.

Comparing with conventional types, supply voltage dependence, overload characteristics and spurious radiation characteristics are improved.

Features

- Wide supply voltage range : $V_{CC} = 1.6\sim 6.0V$
- Excellent supply voltage dependence of local oscillator : Oscillation stop
: $V_{CC} = 0.9V$ (typ.)
- Improved inter-modulation characteristics by double balanced type mixer circuit.
- Low spurious radiation.
- Built-in clamping diode for the local oscillator output.

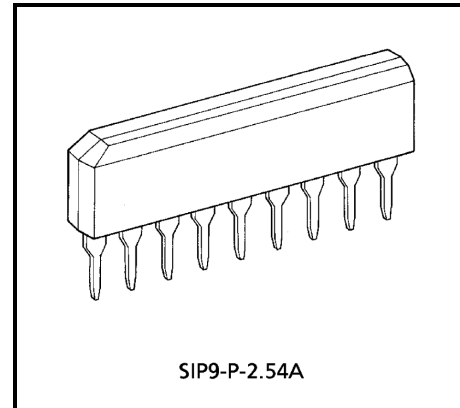

Weight: 0.92g (typ.)

Block Diagram

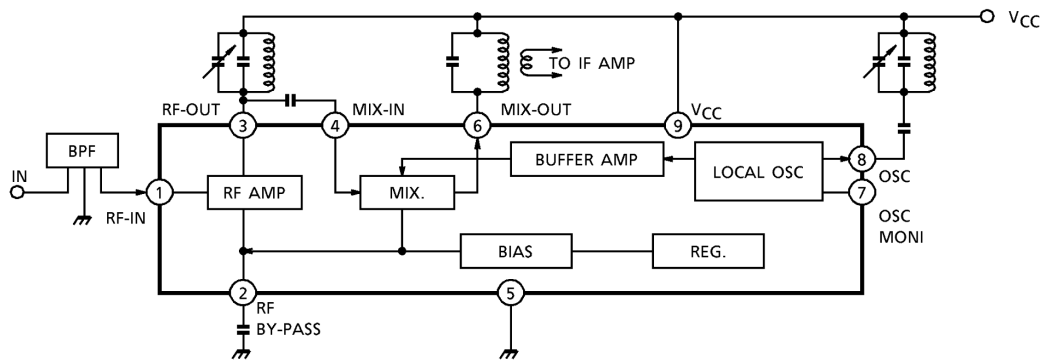

Explanation Of Terminals (terminal voltage is DC voltage at Ta = 25°C, VCC = 5V, and no signal)

Pin No.	Symbol	Internal	Terminal Voltage (V)
1	FM-RF IN		0.8
2	BY PASS		1.5
3	FM-RF OUT		5.0
4	MIX IN		1.5
5	GND	—	0
6	MIX OUT	cf. pin(4)	5.0
7	OSC MONITOR		4.3
8	OSC		5.0
9	VCC	—	5.0

Absolute Maximum Ratings (Ta = 25°C)

Characteristic	Symbol	Rating	Unit
Supply voltage	V _{CC}	8	V
Power dissipation	P _D (Note)	500	mW
Operating temperature	T _{opr}	-25~75	°C
Storage temperature	T _{stg}	-55~150	°C

(Note) Derated above 25°C in the proportion of 4mW / °C.

Electrical Characteristics (V_{CC} = 3V, f = 83MHz, f_m = 1kHz, Δf = ±22.5kHz, Ta = 25°C)

Characteristic		Symbol	Test Cir-cuit	Test Condition	Min.	Typ.	Max.	Unit
Supply current		I _{CC}	2	V _{in} = 0	—	5.2	8.0	mA
-3dB limiting sensitivity		V _{in(lim)}	2	—	—	3.0	7.0	dBμV EMF
Quiescent sensitivity		Q _S	2	—	—	11.0	—	dBμV EMF
Conversion gain		G _C	—	—	—	31	—	dB
Local OSC voltage		V _{OSC}	1	f _{OSC} = 60MHz	90	165	220	mV _{rms}
Pin (1) impedance	Parallel input resistance	r _{ip1}	3	f = 83MHz	—	57	—	Ω
Pin (3) impedance	Parallel output resistance	r _{op3}	3		—	25	—	kΩ
	Parallel output capacitance	c _{op3}			—	2.0	—	pF
Pin (4) impedance	Parallel input resistance	r _{ip4}	3		—	2.7	—	kΩ
	Parallel input capacitance	c _{ip4}			—	3.3	—	pF
Pin (6) impedance	Parallel output resistance	r _{op6}	3		f = 10.7MHz	—	100	—
	Parallel output capacitance	c _{op6}		—		4.8	—	pF
Local OSC stop voltage		V _{stop}	1	—	—	0.9	1.3	V

Test Circuit 1

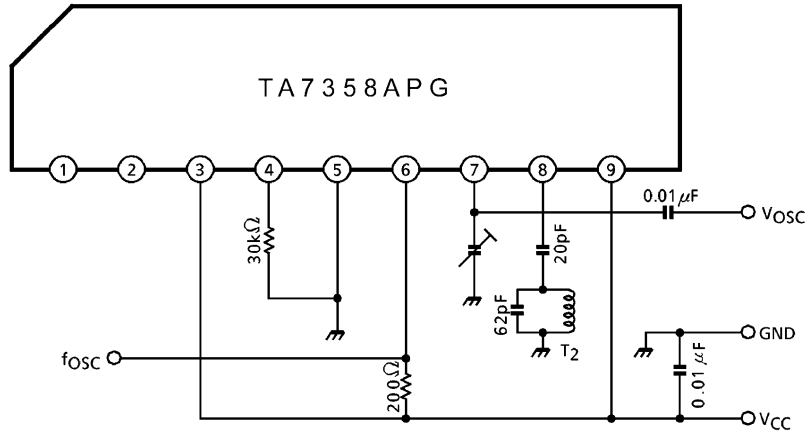

Test Circuit 2

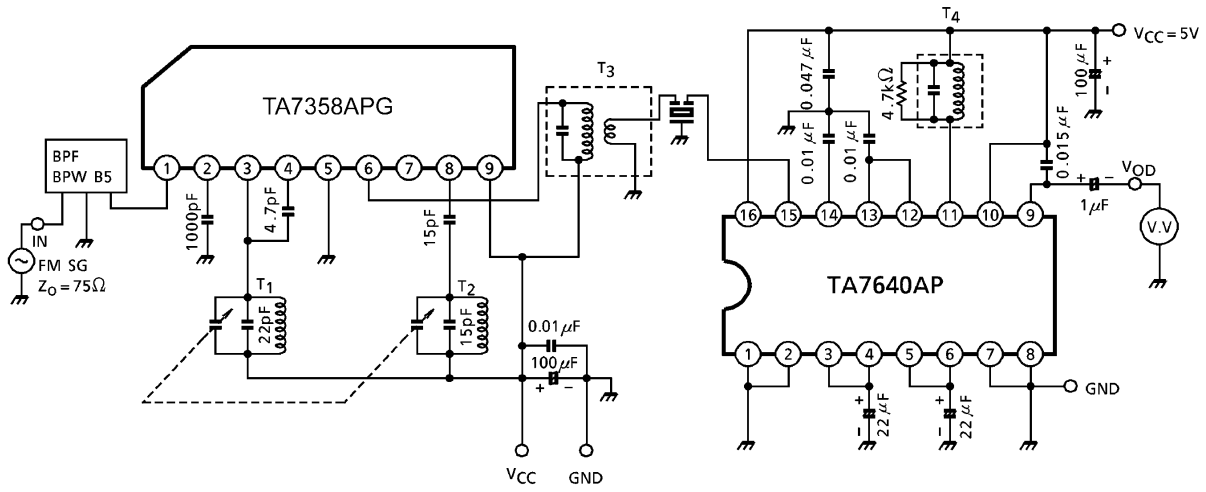

Test Circuit 3

Input output impedance

(1) r_{ip1} , c_{ip1}

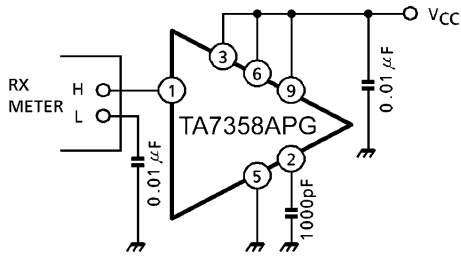

(2) r_{op3} , c_{op3}

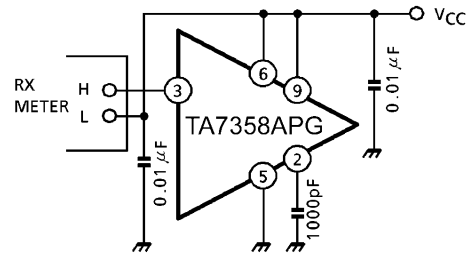

(3) r_{ip4} , c_{ip4}

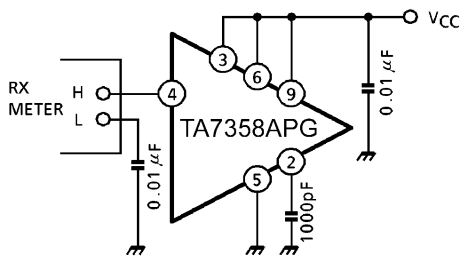

(4) r_{op6} , c_{op6}

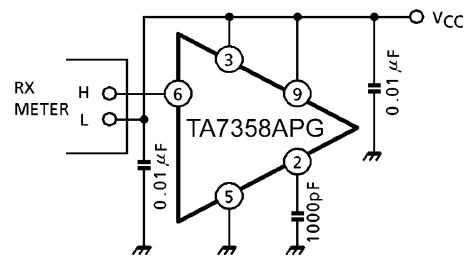

Test Circuit Coil Data (Japan band for 76.0MHz to 108.0MHz)

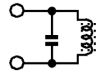
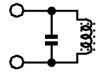
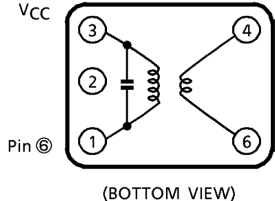
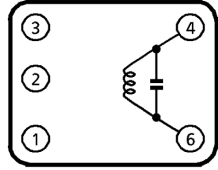
Coil	f_o	Q_o	Turns	Capacitance	
T ₁ RF coil	100MHz	100	0.5mm ϕ 2 $\frac{1}{4}$ T Center tap (Japan band)	15pF (external)	 FERRITE CORE
T ₂ OSC coil	100MHz	100	0.5mm ϕ 2 $\frac{1}{2}$ T (Japan band)	15pF (external)	 FERRITE CORE
T ₃ IFT coil	10.7MHz	115	(1)-(3) 12T (4)-(6) 1T Wire 0.12mm ϕ UEW SUMIDA ELECTRIC Co., LTD 5764 or equivalent	75pF	 (BOTTOM VIEW)
T ₄ Quad coil	10.7MHz	150	(4)-(6) 14T Wire 0.12mm ϕ UEW SUMIDA ELECTRIC Co., LTD 44M-933A or equivalent	47pF	 (BOTTOM VIEW)

Band pass filter (BPF)

SOSHIN ELECTRIC Co., LTD. BPWB5

Tuning capacitor

ALPS ELECTRIC Co., LTD. CB41EL933

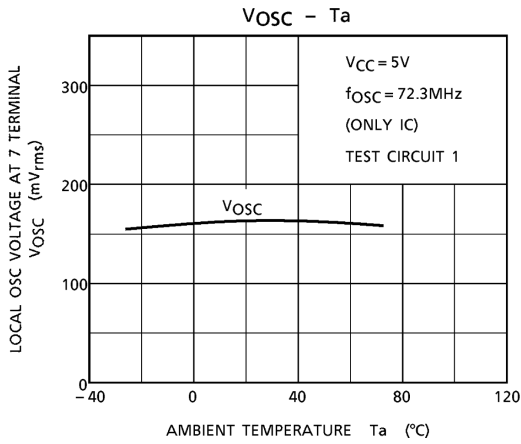
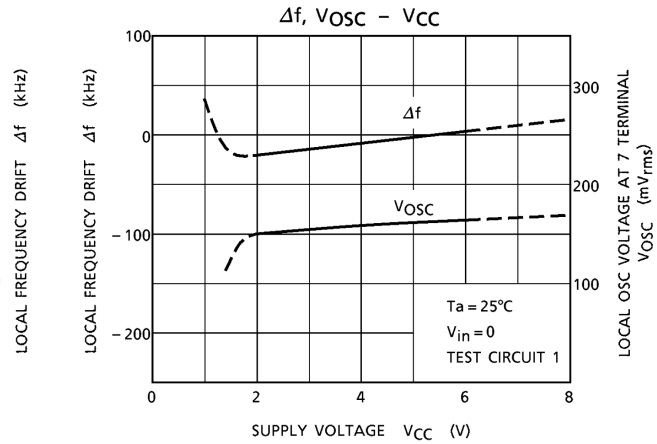
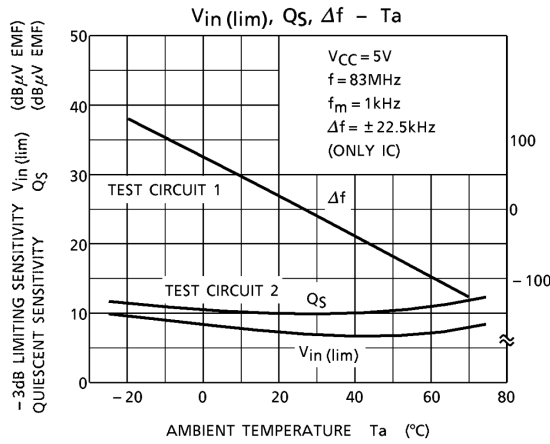
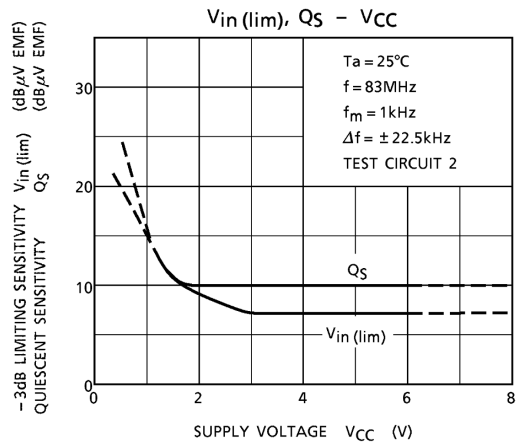
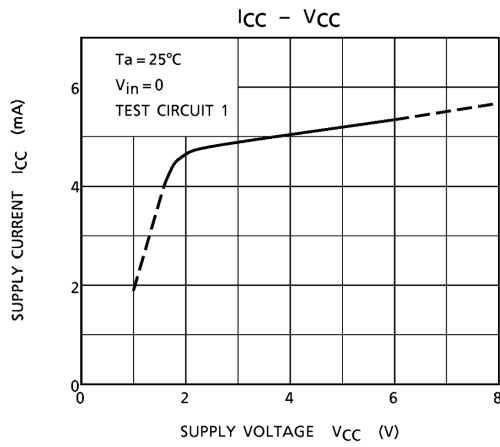

Package Dimensions

SIP9-P-2.54A

Unit : mm

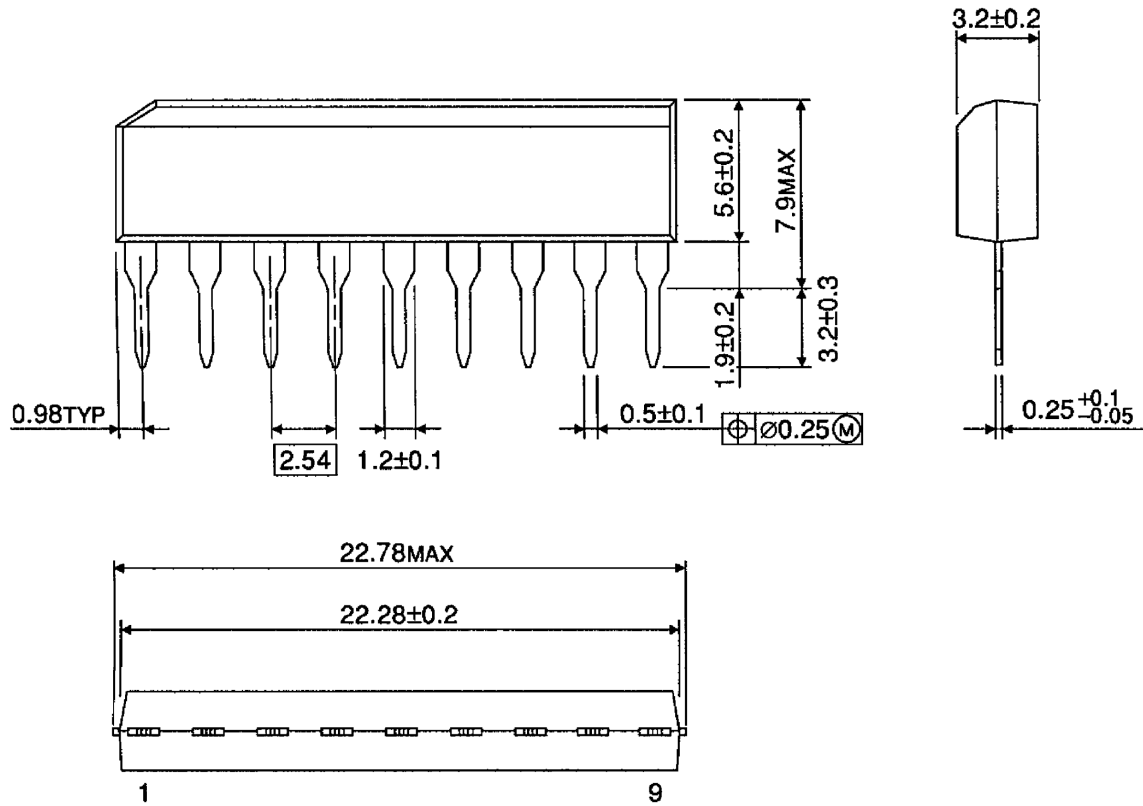

Weight : 0.92g (typ.)

RESTRICTIONS ON PRODUCT USE

060116EBA

- The information contained herein is subject to change without notice. 021023_D
- TOSHIBA is continually working to improve the quality and reliability of its products. Nevertheless, semiconductor devices in general can malfunction or fail due to their inherent electrical sensitivity and vulnerability to physical stress. It is the responsibility of the buyer, when utilizing TOSHIBA products, to comply with the standards of safety in making a safe design for the entire system, and to avoid situations in which a malfunction or failure of such TOSHIBA products could cause loss of human life, bodily injury or damage to property.
In developing your designs, please ensure that TOSHIBA products are used within specified operating ranges as set forth in the most recent TOSHIBA products specifications. Also, please keep in mind the precautions and conditions set forth in the "Handling Guide for Semiconductor Devices," or "TOSHIBA Semiconductor Reliability Handbook" etc. 021023_A
- The TOSHIBA products listed in this document are intended for usage in general electronics applications (computer, personal equipment, office equipment, measuring equipment, industrial robotics, domestic appliances, etc.). These TOSHIBA products are neither intended nor warranted for usage in equipment that requires extraordinarily high quality and/or reliability or a malfunction or failure of which may cause loss of human life or bodily injury ("Unintended Usage"). Unintended Usage include atomic energy control instruments, airplane or spaceship instruments, transportation instruments, traffic signal instruments, combustion control instruments, medical instruments, all types of safety devices, etc. Unintended Usage of TOSHIBA products listed in this document shall be made at the customer's own risk. 021023_B
- The products described in this document shall not be used or embedded to any downstream products of which manufacture, use and/or sale are prohibited under any applicable laws and regulations. 060106_Q
- The information contained herein is presented only as a guide for the applications of our products. No responsibility is assumed by TOSHIBA for any infringements of patents or other rights of the third parties which may result from its use. No license is granted by implication or otherwise under any patent or patent rights of TOSHIBA or others. 021023_C
- The products described in this document are subject to the foreign exchange and foreign trade laws. 021023_E

About solderability, following conditions were confirmed

- Solderability
 - (1) Use of Sn-37Pb solder Bath
 - solder bath temperature = 230°C
 - dipping time = 5 seconds
 - the number of times = once
 - use of R-type flux
 - (2) Use of Sn-3.0Ag-0.5Cu solder Bath
 - solder bath temperature = 245°C
 - dipping time = 5 seconds
 - the number of times = once
 - use of R-type flux