

## DUAL ADVANCED MODULATION SATELLITE RECEIVER

### FEATURES

- **Dual direct conversion satellite tuners**
  - Direct conversion architecture in standard CMOS process
  - Supports QPSK and 8PSK demodulation
  - Input frequency range: 250 to 2150 MHz
  - Integrated 8-bit A/D converters
- **Dual advanced demodulation decoders**
  - DVB-S2 Broadcast, DVB-S, 8PSK Turbo
- **Data Rates:**
  - DVB-S: 1-45 Msps
  - DVB-S2: 5-33 Msps
  - 8PSK Turbo: 2-30 Msps
- **Code Rates:**  $1/4, 1/3, 2/5, 1/2, 3/5, 2/3, 3/4, 4/5, 5/6, 8/9, 9/10$
- **Integrated dual DiSEqC 2.x transceivers**
- **Programmable FSK transceiver**
- **On-chip microcontroller for acquisition and tracking**
- **128-pin eLQFP package**

### SUMMARY OF BENEFITS

- **Highly integrated, cost effective front-end solution for advanced modulation satellite systems in a single package**
- **Ideal for next-generation PVR satellite systems and Home Media Centers, supporting DVB-S2 Broadcast while maintaining backward-compatible support for DVB-S legacy transmissions.**
- **Advanced design architecture requires no external RAM.**
- **MPEG-2 transport output interfaces provide glueless system integration with Broadcom® integrated audio/video decoders.**
- **Integrated microcontroller for receiver operations, including configuration, acquisition and performance monitoring.**
- **Host interface operates via high-level API to reduce software development time and to simplify system integration.**
- **Small footprint and low power consumption**

### BCM4506 System Block Diagram Example

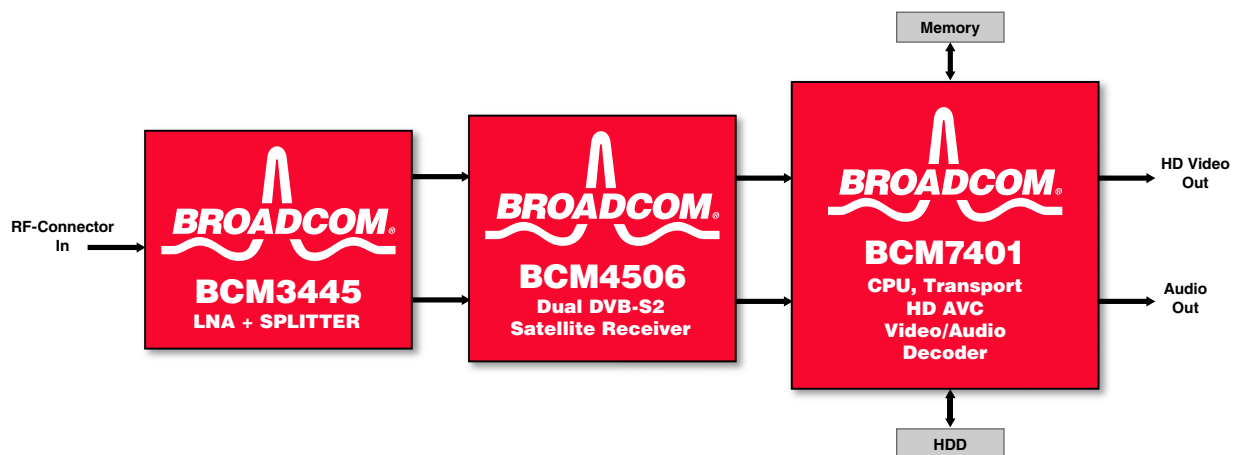

# OVERVIEW

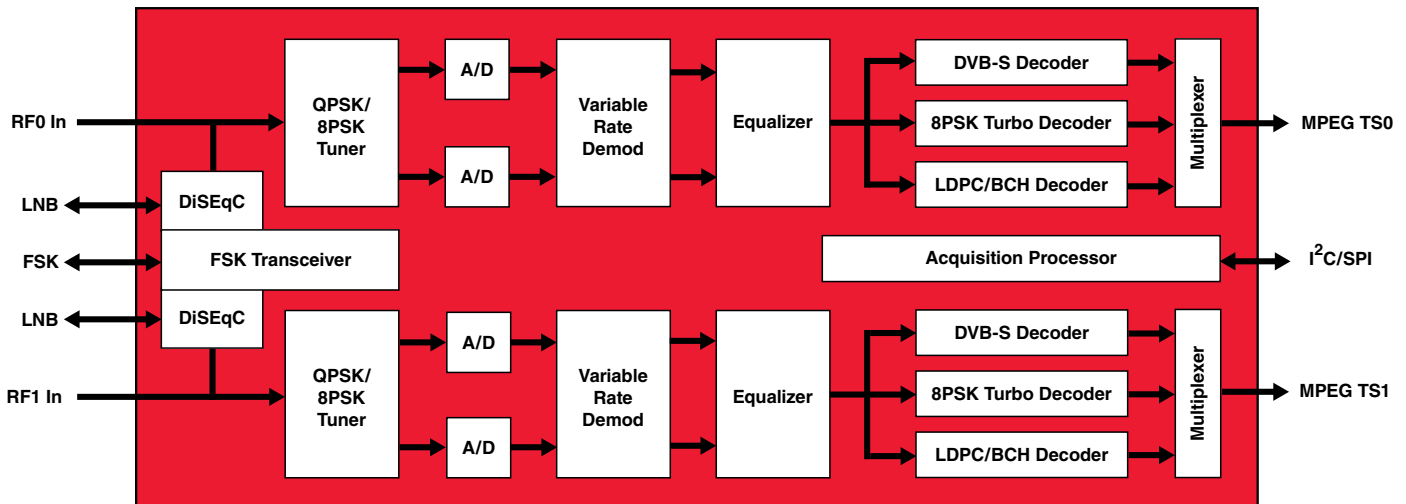

**BCM4506 Block Diagram**

The BCM4506 is a fully integrated dual satellite receiver single-chip solution targeted at multituner advanced-modulation satellite receiver systems and ideally suited for new-generation PVR-satellite receivers and integrated multifunction Home Media Centers.

The BCM4506 integrates dual CMOS tuners and dual advanced modulation decoders supporting DVB-S2 Broadcast, DVB-S, DIRECTV®, and 8PSK Turbo applications. The highly integrated tuner sections are based on existing, volume-production Broadcom technologies and a direct-conversion technology to reduce external components and increase performance.

The BCM4506 is designed to support the full 1-45 Msps DVB operating range with support for 250 to 2150 MHz input frequencies.

It contains four 8-bit A/D converters, all digital variable rate QPSK/8PSK receivers, an advanced modulation LDPC/BCH and Turbo FEC decoder, and a DVB-S compliant FEC decoder. All required RAM is integrated and all required clocks are generated on-chip from a single reference crystal. The baseband IQ analog waveforms from the tuner

sections are sampled by the integrated 8-bit A/D converters and resampled by the integrated interpolative digital filter banks.

Optimized soft decisions are then fed into either a DVB-S-compliant FEC decoder, or an advanced modulation DVB-S2 LDPC/BCH or Turbo decoder. The final error-corrected output is delivered in MPEG-2 transport format. The output clock is generated by an on-chip PLL for low-jitter operation and glueless integration with Broadcom's high definition audio video subsystems, such as the BCM7400 and the BCM7401.

The communication link sections include an on-chip microcontroller for all system configuration, acquisition, control, monitoring and diagnostics functions, as well as dual integrated DiSEqC2.x controllers for 2-way communication with LNBS, and a single FSK transceiver for communication with ODUs that support multiple LNB configurations over a single coax connection.

The BCM94506 reference design is available for easy system design and testing using the BCM4506 dual advanced modulation satellite receiver chip. Schematics, Gerber files and evaluation software are available.

Broadcom®, the pulse logo, Connecting everything®, and the Connecting everything logo are among the trademarks of Broadcom Corporation and/or its affiliates in the United States, certain other countries and/or the EU. Any other trademarks or trade names mentioned are the property of their respective owners.

Connecting  
everything®



**BROADCOM CORPORATION**

5300 California Avenue  
Irvine, California 92617

© 2007 by BROADCOM CORPORATION. All rights reserved.

4506-PB00-R 07/16/07

Phone: 949-926-5000  
Fax: 949-926-5203  
E-mail: info@broadcom.com  
Web: www.broadcom.com