

RAD-HARD QUAD 2 CHANNEL MULTIPLEXER (3-STATE)

- HIGH SPEED:
 $t_{PD} = 11 \text{ ns (TYP.) at } V_{CC} = 6V$
- LOW POWER DISSIPATION:
 $I_{CC} = 4\mu A(\text{MAX.}) \text{ at } T_A = 25^\circ C$
- HIGH NOISE IMMUNITY:
 $V_{NIH} = V_{NIL} = 28\% V_{CC} (\text{MIN.})$
- SYMMETRICAL OUTPUT IMPEDANCE:
 $|I_{OH}| = I_{OL} = 6mA (\text{MIN})$
- BALANCED PROPAGATION DELAYS:
 $t_{PLH} \cong t_{PHL}$
- WIDE OPERATING VOLTAGE RANGE:
 $V_{CC} (\text{OPR}) = 2V \text{ to } 6V$
- PIN AND FUNCTION COMPATIBLE WITH 54 SERIES 257
- SPACE GRADE-1: ESA SCC QUALIFIED
- 50 krad QUALIFIED, 100 krad AVAILABLE ON REQUEST
- NO SEL UNDER HIGH LET HEAVY IONS IRRADIATION
- DEVICE FULLY COMPLIANT WITH SCC-9408-047

DESCRIPTION

The M54HC257 is a high speed CMOS QUAD 2 CHANNEL MULTIPLEXER (3-STATE) fabricated with silicon gate C²MOS technology.

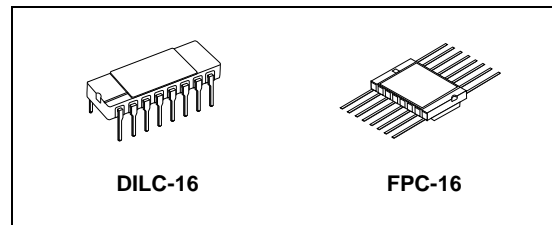

ORDER CODES

PACKAGE	FM	EM
DILC	M54HC257D	M54HC257D1
FPC	M54HC257K	M54HC257K1

This IC is composed of an independent 2-channel multiplexer with common SELECT and ENABLE (OE) input.

The M74HC257 is a non-inverting multiplexer. When the ENABLE input is held "High", outputs of the IC become in a High-Impedance state. If SELECT input is held low, "A" data is selected, when SELECT is high, "B" data is chosen.

All inputs are equipped with protection circuits against static discharge and transient excess voltage.

PIN CONNECTION

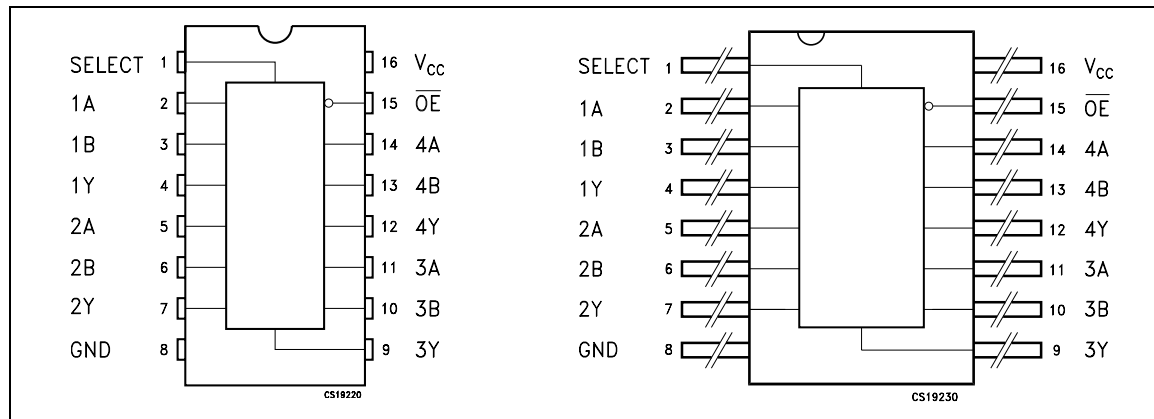

IEC LOGIC SYMBOLS

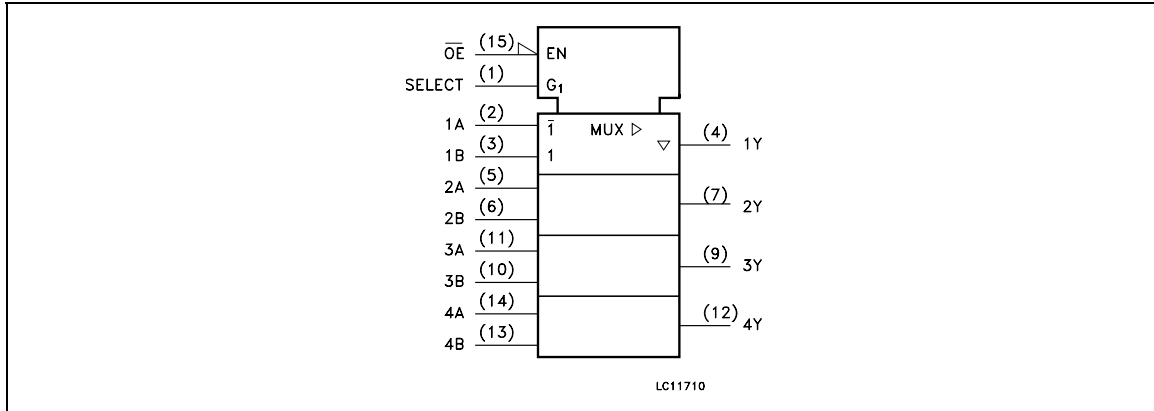

INPUT AND OUTPUT EQUIVALENT CIRCUIT

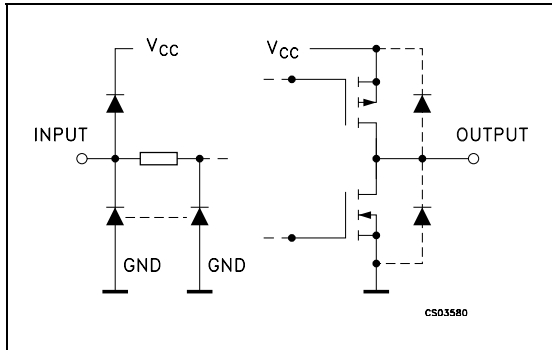

PIN DESCRIPTION

PIN N°	SYMBOL	NAME AND FUNCTION
1	SELECT	Common Data Select Input
2, 5, 14, 11	1A to 4A	Data Input From Source A
3, 6, 13, 10	1B to 4B	Data Input From Source B
4, 7, 12, 9	1Y to 4Y	3 State Multiplexer Outputs
15	\overline{OE}	3 State Output Enable Inputs (Active Low)
8	GND	Ground (0V)
16	V _{CC}	Positive Supply Voltage

TRUTH TABLE

INPUTS				OUTPUT
\overline{OE}	SELECT	A	B	Y
H	X	X	X	Z
L	L	L	X	L
L	L	H	X	H
L	H	X	L	L
L	H	X	H	H

X : Don't Care
Z : High Impedance

LOGIC DIAGRAM

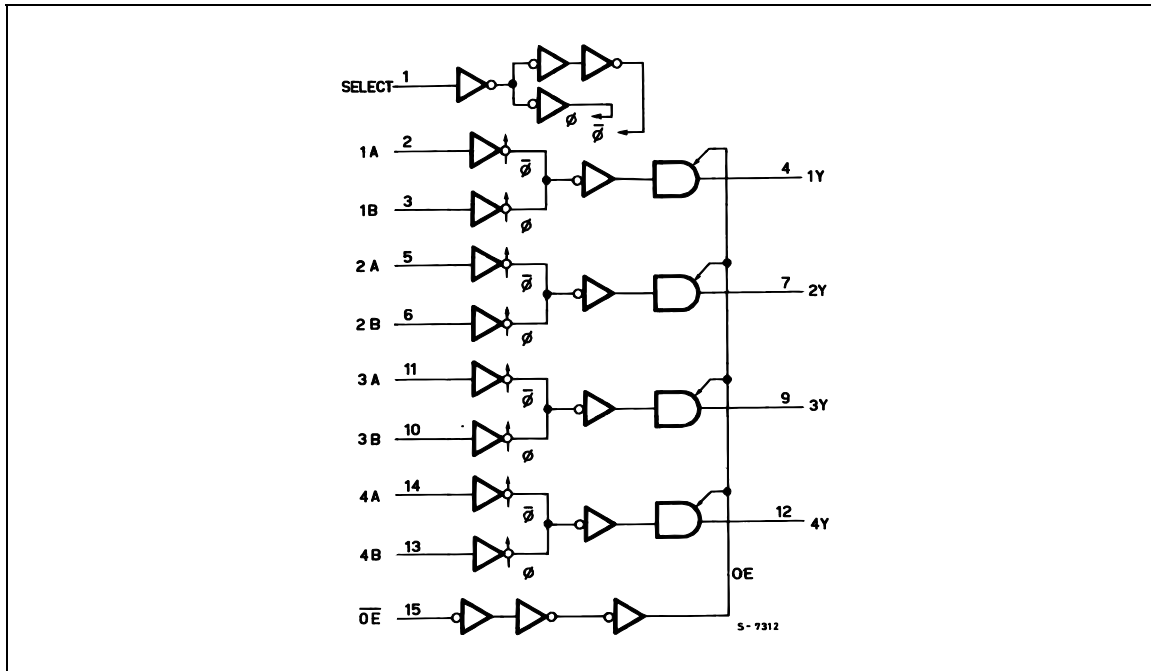

This logic diagram has not be used to estimate propagation delays

ABSOLUTE MAXIMUM RATINGS

Symbol	Parameter	Value	Unit
V_{CC}	Supply Voltage	-0.5 to +7	V
V_I	DC Input Voltage	-0.5 to $V_{CC} + 0.5$	V
V_O	DC Output Voltage	-0.5 to $V_{CC} + 0.5$	V
I_{IK}	DC Input Diode Current	± 20	mA
I_{OK}	DC Output Diode Current	± 20	mA
I_O	DC Output Current	± 35	mA
I_{CC} or I_{GND}	DC V_{CC} or Ground Current	± 70	mA
P_D	Power Dissipation	420	mW
T_{stg}	Storage Temperature	-65 to +150	$^{\circ}\text{C}$
T_L	Lead Temperature (10 sec)	265	$^{\circ}\text{C}$

Absolute Maximum Ratings are those values beyond which damage to the device may occur. Functional operation under these conditions is not implied

M54HC257

RECOMMENDED OPERATING CONDITIONS

Symbol	Parameter	Value	Unit	
V_{CC}	Supply Voltage	2 to 6	V	
V_I	Input Voltage	0 to V_{CC}	V	
V_O	Output Voltage	0 to V_{CC}	V	
T_{op}	Operating Temperature	-55 to 125	°C	
t_r, t_f	Input Rise and Fall Time	$V_{CC} = 2.0V$	0 to 1000	ns
		$V_{CC} = 4.5V$	0 to 500	ns
		$V_{CC} = 6.0V$	0 to 400	ns

DC SPECIFICATIONS

Symbol	Parameter	Test Condition		Value						Unit	
		V_{CC} (V)		$T_A = 25^\circ C$			-40 to 85°C		-55 to 125°C		
				Min.	Typ.	Max.	Min.	Max.	Min.		Max.
V_{IH}	High Level Input Voltage	2.0		1.5			1.5		1.5		V
		4.5		3.15			3.15		3.15		
		6.0		4.2			4.2		4.2		
V_{IL}	Low Level Input Voltage	2.0				0.5		0.5		0.5	V
		4.5				1.35		1.35		1.35	
		6.0				1.8		1.8		1.8	
V_{OH}	High Level Output Voltage	2.0	$I_O = -20 \mu A$	1.9	2.0		1.9		1.9		V
		4.5	$I_O = -20 \mu A$	4.4	4.5		4.4		4.4		
		6.0	$I_O = -20 \mu A$	5.9	6.0		5.9		5.9		
		4.5	$I_O = -6.0 mA$	4.18	4.31		4.13		4.10		
		6.0	$I_O = -7.8 mA$	5.68	5.8		5.63		5.60		
V_{OL}	Low Level Output Voltage	2.0	$I_O = 20 \mu A$		0.0	0.1		0.1		0.1	V
		4.5	$I_O = 20 \mu A$		0.0	0.1		0.1		0.1	
		6.0	$I_O = 20 \mu A$		0.0	0.1		0.1		0.1	
		4.5	$I_O = 6.0 mA$		0.17	0.26		0.33		0.40	
		6.0	$I_O = 7.8 mA$		0.18	0.26		0.33		0.40	
I_I	Input Leakage Current	6.0	$V_I = V_{CC}$ or GND			± 0.1		± 1		± 1	μA
I_{OZ}	High Impedance Output Leakage Current	6.0	$V_I = V_{IH}$ or V_{IL} $V_O = V_{CC}$ or GND			± 0.5		± 5		± 10	μA
I_{CC}	Quiescent Supply Current	6.0	$V_I = V_{CC}$ or GND			4		40		80	μA

AC ELECTRICAL CHARACTERISTICS ($C_L = 50 \text{ pF}$, Input $t_r = t_f = 6 \text{ ns}$)

Symbol	Parameter	Test Condition			Value						Unit	
		V_{CC} (V)			$T_A = 25^\circ\text{C}$			$-40 \text{ to } 85^\circ\text{C}$		$-55 \text{ to } 125^\circ\text{C}$		
					Min.	Typ.	Max.	Min.	Max.	Min.		Max.
t_{TLH} t_{THL}	Output Transition Time	2.0	50			25	60		75		90	ns
		4.5				7	12		15		19	
		6.0				6	10		13		15	
t_{PLH} t_{PHL}	Propagation Delay Time (A, B - Y)	2.0	50			45	100		125		150	ns
		4.5				13	20		25		30	
		6.0				11	17		21		26	
		2.0	150			62	140		175		210	ns
		4.5				18	28		35		42	
		6.0				15	24		30		36	
t_{PLH} t_{PHL}	Propagation Delay Time (SELECT - Y)	2.0	50			45	100		125		150	ns
		4.5				13	20		25		30	
		6.0				11	17		21		26	
		2.0	150			62	140		175		210	ns
		4.5				18	28		35		42	
		6.0				15	24		30		36	
t_{PZL} t_{PZH}	High Impedance Output Enable Time	2.0	50	$R_L = 1 \text{ K}\Omega$		40	110		140		165	ns
		4.5				12	22		28		33	
		6.0				10	19		24		28	
		2.0	150	$R_L = 1 \text{ K}\Omega$		57	150		190		225	ns
		4.5				17	30		38		45	
		6.0				14	26		32		38	
t_{PLZ} t_{PHZ}	High Impedance Output Disable Time	2.0	50	$R_L = 1 \text{ K}\Omega$		28	140		175		210	ns
		4.5				14	28		35		42	
		6.0				13	24		30		36	

CAPACITIVE CHARACTERISTICS

Symbol	Parameter	Test Condition			Value						Unit	
		V_{CC} (V)			$T_A = 25^\circ\text{C}$			$-40 \text{ to } 85^\circ\text{C}$		$-55 \text{ to } 125^\circ\text{C}$		
					Min.	Typ.	Max.	Min.	Max.	Min.		Max.
C_{IN}	Input Capacitance					5	10		10		10	pF
C_{OUT}	Output Capacitance					10						pF
C_{PD}	Power Dissipation Capacitance (note 1)					47						pF

1) C_{PD} is defined as the value of the IC's internal equivalent capacitance which is calculated from the operating current consumption without load. (Refer to Test Circuit). Average operating current can be obtained by the following equation. $I_{CC(opr)} = C_{PD} \times V_{CC} \times f_{IN} + I_{CC}/4$ (per Channel)

TEST CIRCUIT

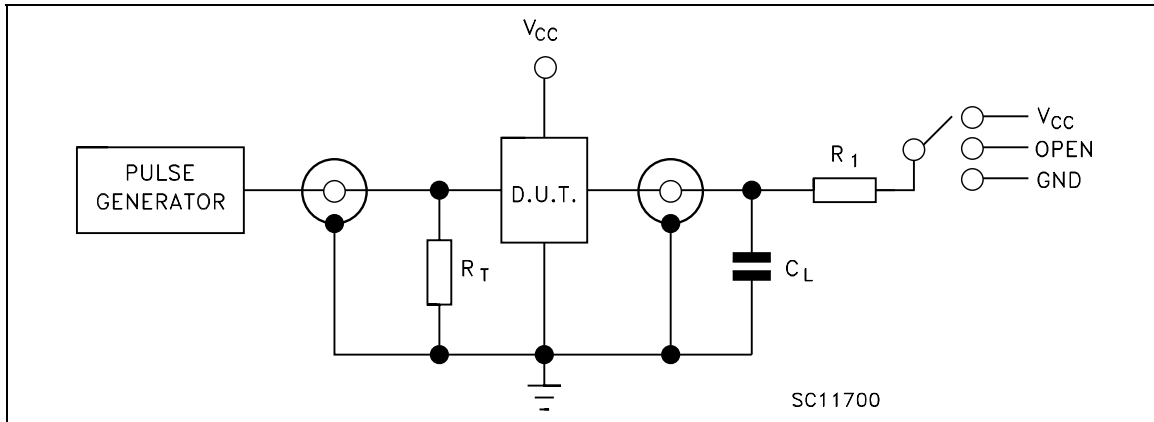

TEST	SWITCH
t_{PLH} , t_{PHL}	Open
t_{PZL} , t_{PLZ}	V_{CC}
t_{PZH} , t_{PHZ}	GND

C_L = 50pF/150pF or equivalent (includes jig and probe capacitance)
 R_1 = 1K Ω or equivalent
 R_T = Z_{OUT} of pulse generator (typically 50 Ω)

WAVEFORM 1: PROPAGATION DELAY TIME (f=1MHz; 50% duty cycle)

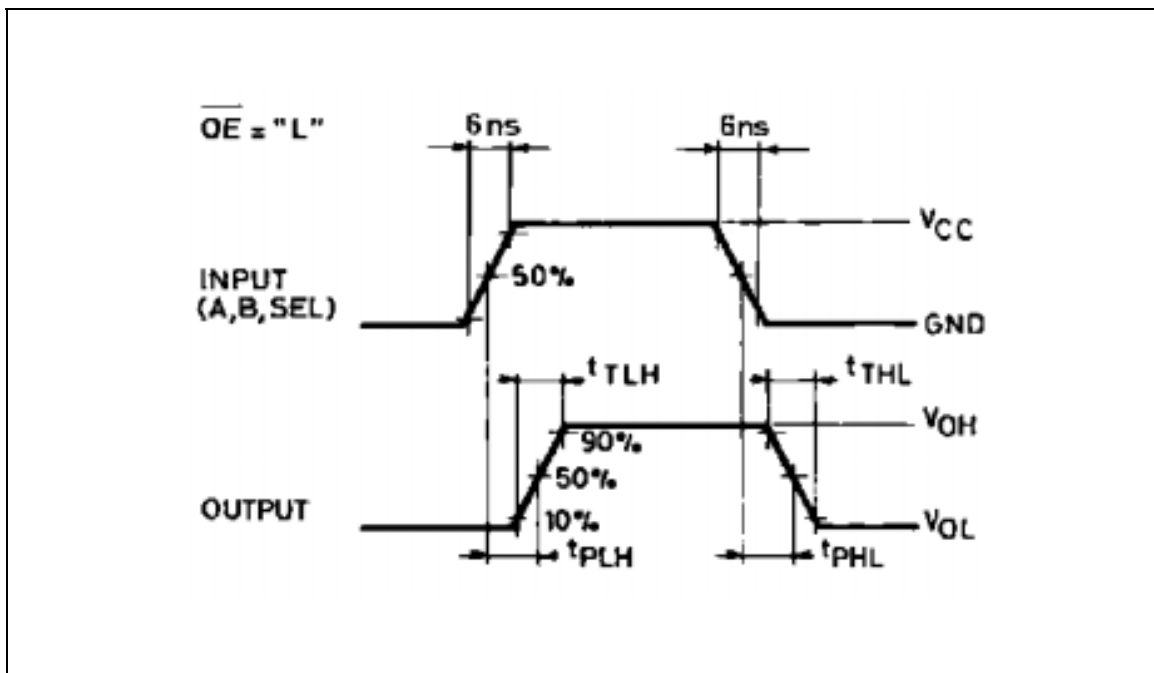

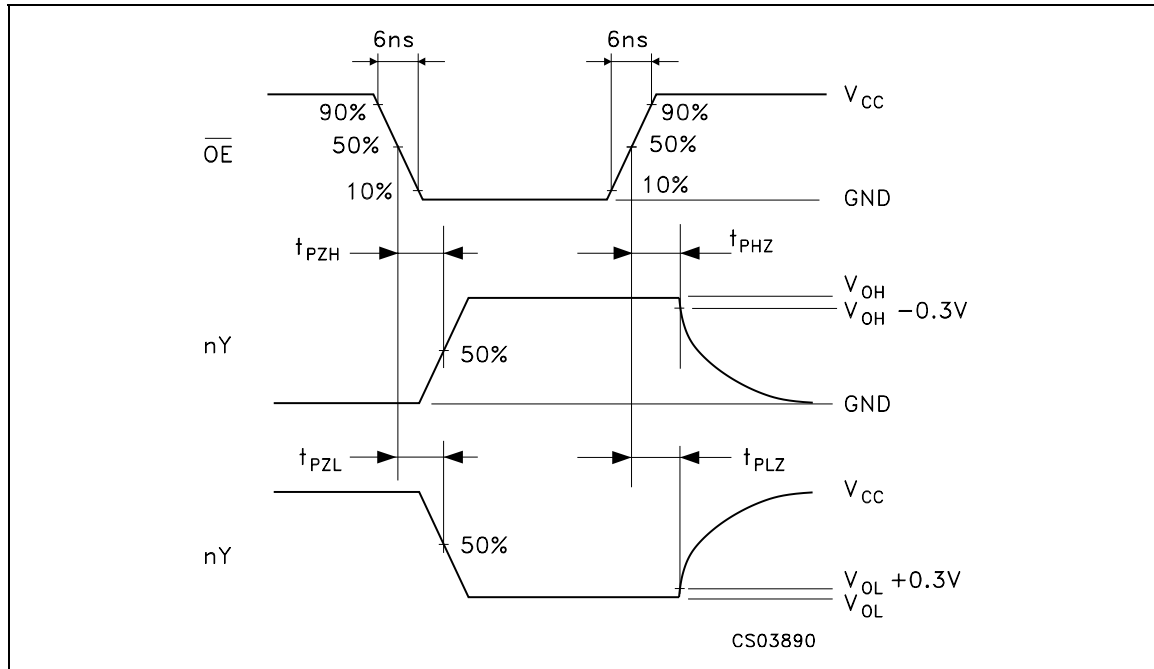
WAVEFORM 2: OUTPUT ENABLE AND DISABLE TIME ($f=1\text{MHz}$; 50% duty cycle)

DILC-16 MECHANICAL DATA

DIM.	mm.			inch		
	MIN.	TYP	MAX.	MIN.	TYP.	MAX.
A	2.1		2.71	0.083		0.107
a1	3.00		3.70	0.118		0.146
a2	0.63	0.88	1.14	0.025	0.035	0.045
B	1.82		2.39	0.072		0.094
b	0.40	0.45	0.50	0.016	0.018	0.020
b1	0.20	0.254	0.30	0.008	0.010	0.012
D	20.06	20.32	20.58	0.790	0.800	0.810
e	7.36	7.62	7.87	0.290	0.300	0.310
e1		2.54			0.100	
e2	17.65	17.78	17.90	0.695	0.700	0.705
e3	7.62	7.87	8.12	0.300	0.310	0.320
F	7.29	7.49	7.70	0.287	0.295	0.303
I			3.83			0.151
K	10.90		12.1	0.429		0.476
L	1.14		1.5	0.045		0.059

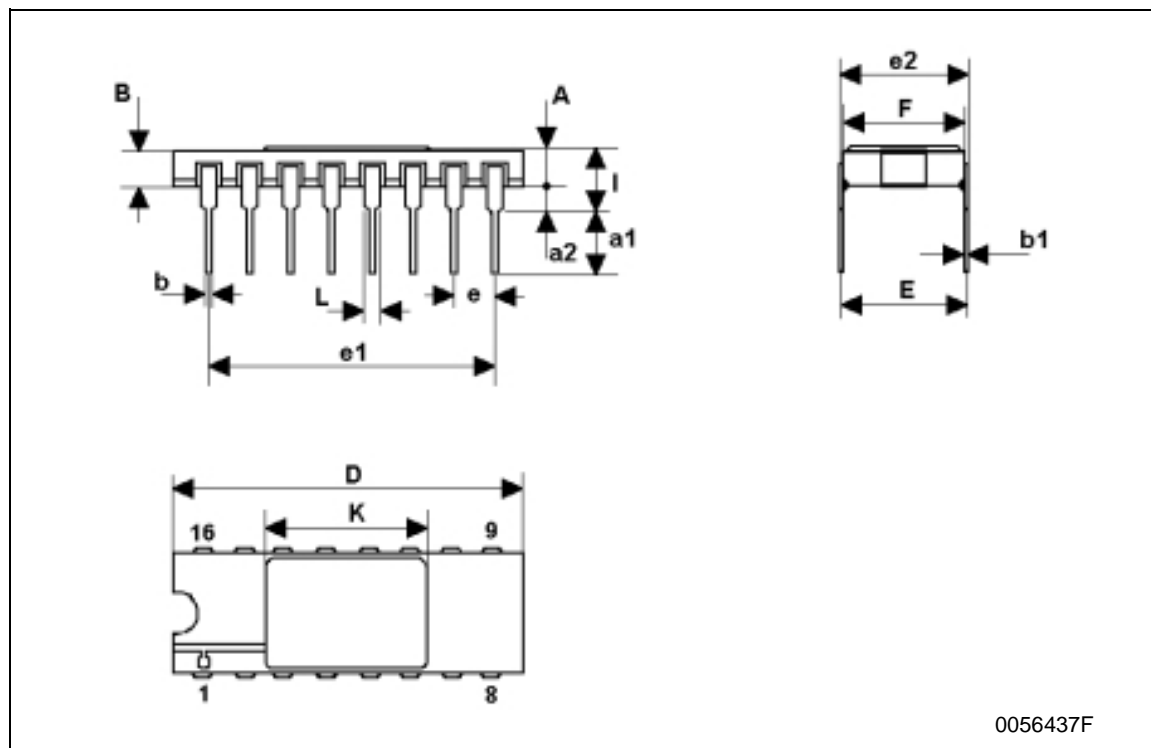

FPC-16 MECHANICAL DATA

DIM.	mm.			inch		
	MIN.	TYP	MAX.	MIN.	TYP.	MAX.
A	6.75	6.91	7.06	0.266	0.272	0.278
B	9.76	9.94	10.14	0.384	0.392	0.399
C	1.49		1.95	0.059		0.077
D	0.102	0.127	0.152	0.004	0.005	0.006
E	8.76	8.89	9.01	0.345	0.350	0.355
F		1.27			0.050	
G	0.38	0.43	0.48	0.015	0.017	0.019
H	6.0			0.237		
L	18.75		22.0	0.738		0.867
M	0.33	0.38	0.43	0.013	0.015	0.017
N		4.31			0.170	

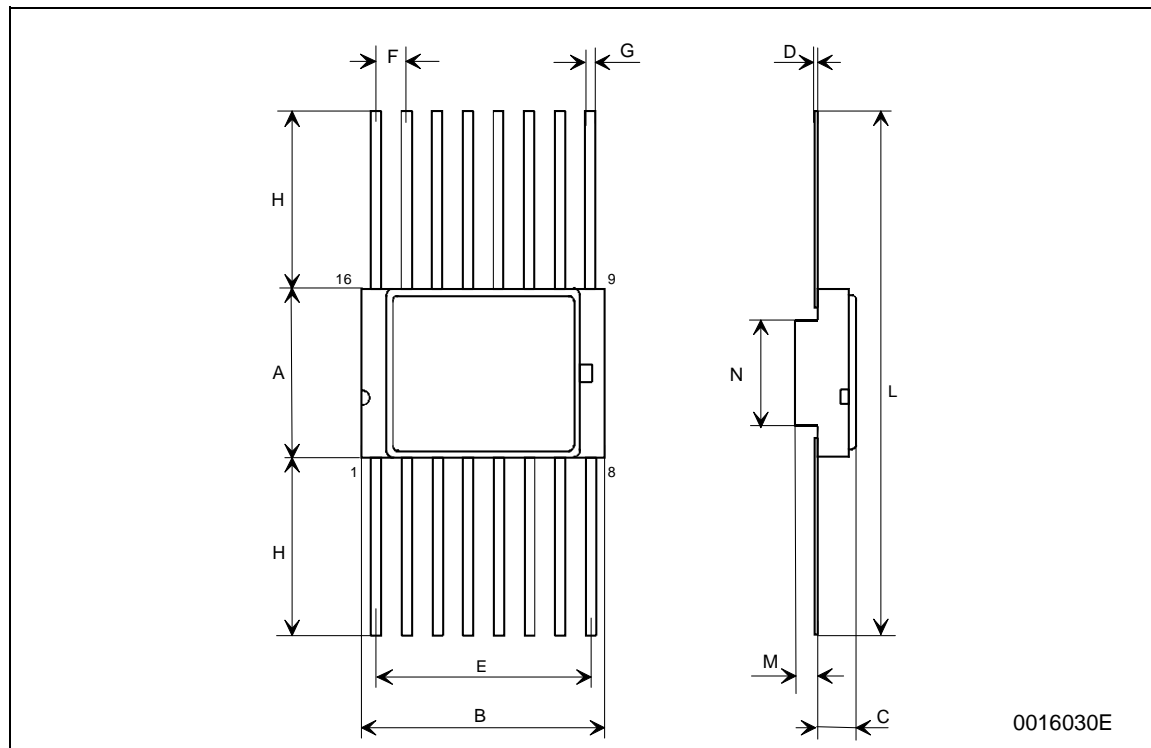

Information furnished is believed to be accurate and reliable. However, STMicroelectronics assumes no responsibility for the consequences of use of such information nor for any infringement of patents or other rights of third parties which may result from its use. No license is granted by implication or otherwise under any patent or patent rights of STMicroelectronics. Specifications mentioned in this publication are subject to change without notice. This publication supersedes and replaces all information previously supplied. STMicroelectronics products are not authorized for use as critical components in life support devices or systems without express written approval of STMicroelectronics.

The ST logo is a registered trademark of STMicroelectronics
All other names are the property of their respective owners

© 2004 STMicroelectronics - All Rights Reserved
STMicroelectronics GROUP OF COMPANIES

Australia - Belgium - Brazil - Canada - China - Czech Republic - Finland - France - Germany - Hong Kong - India - Israel - Italy - Japan - Malaysia - Malta - Morocco - Singapore - Spain - Sweden - Switzerland - United Kingdom - United States.

<http://www.st.com>