

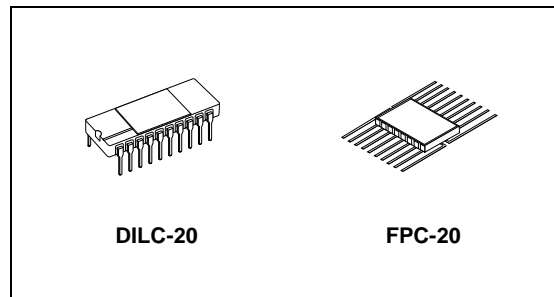

M54HC245

RAD-HARD OCTAL BUS TRANSCEIVER WITH 3 STATE OUTPUTS (NON INVERTED)

- HIGH SPEED:
 $t_{PD} = 10\text{ns}$ (TYP.) at $V_{CC} = 6\text{V}$
- LOW POWER DISSIPATION:
 $I_{CC} = 4\mu\text{A}$ (MAX.) at $T_A=25^\circ\text{C}$
- HIGH NOISE IMMUNITY:
 $V_{NIH} = V_{NIL} = 28\% V_{CC}$ (MIN.)
- SYMMETRICAL OUTPUT IMPEDANCE:
 $|I_{OH}| = I_{OL} = 6\text{mA}$ (MIN)
- BALANCED PROPAGATION DELAYS:
 $t_{PLH} \cong t_{PHL}$
- WIDE OPERATING VOLTAGE RANGE:
 V_{CC} (OPR) = 2V to 6V
- PIN AND FUNCTION COMPATIBLE WITH 54 SERIES 245
- SPACE GRADE-1: ESA SCC QUALIFIED
- 50 krad QUALIFIED, 100 krad AVAILABLE ON REQUEST
- NO SEL UNDER HIGH LET HEAVY IONS IRRADIATION
- DEVICE FULLY COMPLIANT WITH SCC-9405-013



ORDER CODES

PACKAGE	FM	EM
DILC	M54HC245D	M54HC245D1
FPC	M54HC245K	M54HC245K1

This IC is intended for two-way asynchronous communication between data buses, and the direction of data transmission is determined by DIR input. The enable input \bar{G} can be used to disable the device so that the buses are effectively isolated.

All inputs are equipped with protection circuits against static discharge and transient excess voltage.

All floating bus terminals during High Z State must be held HIGH or LOW.

DESCRIPTION

The M54HC245 is an advanced high-speed CMOS OCTAL BUS TRANSCEIVER (3-STATE) fabricated with silicon gate C²MOS technology.

PIN CONNECTION

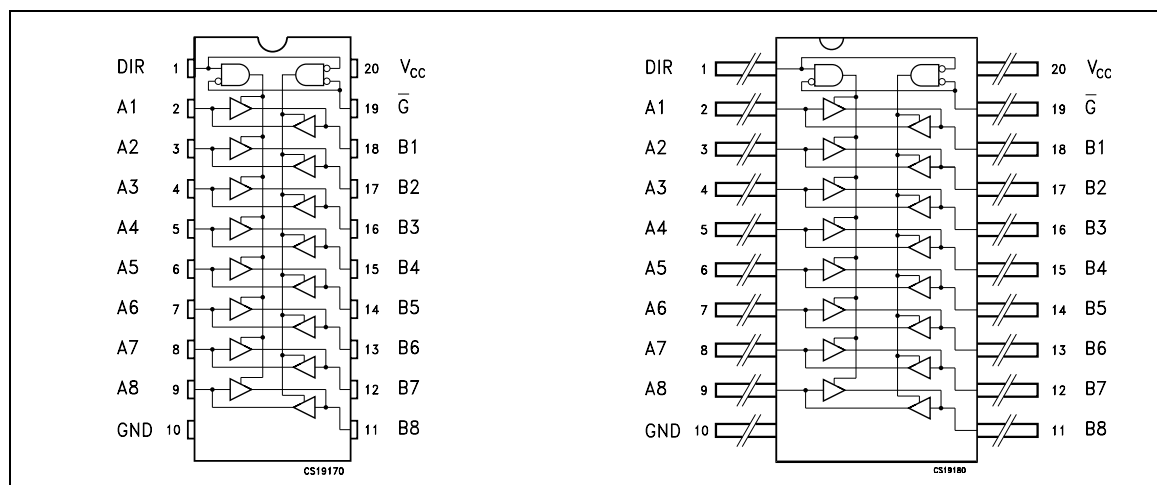

IEC LOGIC SYMBOLS

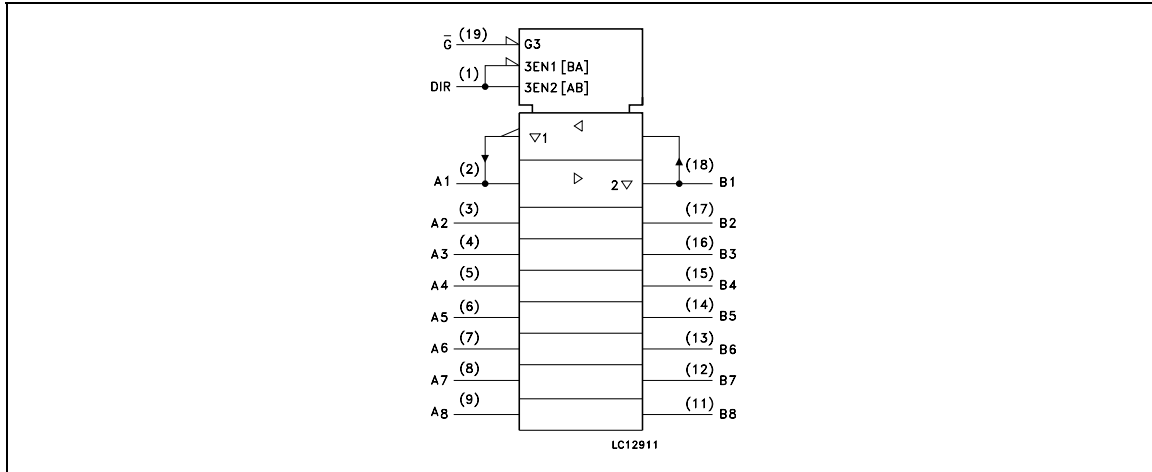

INPUT AND OUTPUT EQUIVALENT CIRCUIT

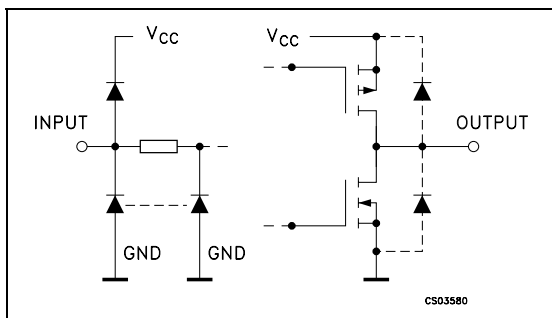

PIN DESCRIPTION

PIN N°	SYMBOL	NAME AND FUNCTION
1	DIR	Directional Control
2, 3, 4, 5, 6, 7, 8, 9	A1 to A8	Data Inputs/Outputs
18, 17, 16, 15, 14, 13, 12, 11	B1 to B8	Data Inputs/Outputs
19	\bar{G}	Output Enable Input
10	GND	Ground (0V)
20	V _{CC}	Positive Supply Voltage

TRUTH TABLE

INPUTS		FUNCTION		OUTPUT
\bar{G}	DIR	A BUS	B BUS	Y _n
L	L	OUTPUT	INPUT	A = B
L	H	INPUT	OUTPUT	B = A
H	X	Z	Z	Z

X : Don't Care
Z : High Impedance

ABSOLUTE MAXIMUM RATINGS

Symbol	Parameter	Value	Unit
V_{CC}	Supply Voltage	-0.5 to +7	V
V_I	DC Input Voltage	-0.5 to $V_{CC} + 0.5$	V
V_O	DC Output Voltage	-0.5 to $V_{CC} + 0.5$	V
I_{IK}	DC Input Diode Current	± 20	mA
I_{OK}	DC Output Diode Current	± 20	mA
I_O	DC Output Current	± 35	mA
I_{CC} or I_{GND}	DC V_{CC} or Ground Current	± 70	mA
P_D	Power Dissipation	420	mW
T_{stg}	Storage Temperature	-65 to +150	$^{\circ}C$
T_L	Lead Temperature (10 sec)	265	$^{\circ}C$

Absolute Maximum Ratings are those values beyond which damage to the device may occur. Functional operation under these conditions is not implied

RECOMMENDED OPERATING CONDITIONS

Symbol	Parameter	Value	Unit	
V_{CC}	Supply Voltage	2 to 6	V	
V_I	Input Voltage	0 to V_{CC}	V	
V_O	Output Voltage	0 to V_{CC}	V	
T_{op}	Operating Temperature	-55 to 125	$^{\circ}C$	
t_r, t_f	Input Rise and Fall Time	$V_{CC} = 2.0V$	0 to 1000	ns
		$V_{CC} = 4.5V$	0 to 500	ns
		$V_{CC} = 6.0V$	0 to 400	ns

DC SPECIFICATIONS

Symbol	Parameter	Test Condition		Value						Unit	
		V _{CC} (V)		T _A = 25°C			-40 to 85°C		-55 to 125°C		
				Min.	Typ.	Max.	Min.	Max.	Min.		Max.
V _{IH}	High Level Input Voltage	2.0		1.5			1.5		1.5		V
		4.5		3.15			3.15		3.15		
		6.0		4.2			4.2		4.2		
V _{IL}	Low Level Input Voltage	2.0				0.5		0.5		0.5	V
		4.5				1.35		1.35		1.35	
		6.0				1.8		1.8		1.8	
V _{OH}	High Level Output Voltage	2.0	I _O = -20 μA	1.9	2.0		1.9		1.9		V
		4.5	I _O = -20 μA	4.4	4.5		4.4		4.4		
		6.0	I _O = -20 μA	5.9	6.0		5.9		5.9		
		4.5	I _O = -6.0 mA	4.18	4.31		4.13		4.10		
		6.0	I _O = -7.8 mA	5.68	5.8		5.63		5.60		
V _{OL}	Low Level Output Voltage	2.0	I _O = 20 μA		0.0	0.1		0.1		0.1	V
		4.5	I _O = 20 μA		0.0	0.1		0.1		0.1	
		6.0	I _O = 20 μA		0.0	0.1		0.1		0.1	
		4.5	I _O = 6.0 mA		0.17	0.26		0.33		0.40	
		6.0	I _O = 7.8 mA		0.18	0.26		0.33		0.40	
I _I	Input Leakage Current	6.0	V _I = V _{CC} or GND			± 0.1		± 1		± 1	μA
I _{OZ}	High Impedance Output Leakage Current	6.0	V _I = V _{IH} or V _{IL} V _O = V _{CC} or GND			± 0.5		± 5		± 10	μA
I _{CC}	Quiescent Supply Current	6.0	V _I = V _{CC} or GND			4		40		80	μA

AC ELECTRICAL CHARACTERISTICS ($C_L = 50$ pF, Input $t_r = t_f = 6$ ns)

Symbol	Parameter	Test Condition			Value						Unit	
		V_{CC} (V)	C_L (pF)		$T_A = 25^\circ\text{C}$			-40 to 85°C		-55 to 125°C		
					Min.	Typ.	Max.	Min.	Max.	Min.		Max.
t_{TLH} t_{THL}	Output Transition Time	2.0	50		25	60		75		90	ns	
		4.5		7	12		19		18			
		6.0		6	10		13		15			
t_{PLH} t_{PHL}	Propagation Delay Time	2.0	50		33	90		115		135	ns	
		4.5		12	18		23		27			
		6.0		10	15		20		23			
		2.0	150		48	120		150		180	ns	
		4.5		16	24		30		36			
		6.0		14	20		26		31			
t_{PZL} t_{PZH}	High Impedance Output Enable Time	2.0	50	$R_L = 1\text{ K}\Omega$	48	150		190		225	ns	
		4.5			16	30		38		45		
		6.0			14	26		32		38		
		2.0	150	$R_L = 1\text{ K}\Omega$	63	180		225		270	ns	
		4.5			21	36		45		54		
		6.0			18	31		38		46		
t_{PLZ} t_{PHZ}	High Impedance Output Disable Time	2.0	50	$R_L = 1\text{ K}\Omega$	37	150		190		225	ns	
		4.5			17	30		38		45		
		6.0			15	26		32		38		

CAPACITIVE CHARACTERISTICS

Symbol	Parameter	Test Condition			Value						Unit	
		V_{CC} (V)			$T_A = 25^\circ\text{C}$			-40 to 85°C		-55 to 125°C		
					Min.	Typ.	Max.	Min.	Max.	Min.		Max.
C_{IN}	Input Capacitance			DIR, \bar{G}		5	10		10		10	pF
$C_{I/OUT}$	Output Capacitance			An, Bn		13						pF
C_{PD}	Power Dissipation Capacitance (note 1)					39						pF

1) C_{PD} is defined as the value of the IC's internal equivalent capacitance which is calculated from the operating current consumption without load. (Refer to Test Circuit). Average operating current can be obtained by the following equation. $I_{CC(oper)} = C_{PD} \times V_{CC} \times f_{IN} + I_{CC}/8$ (per circuit)

TEST CIRCUIT

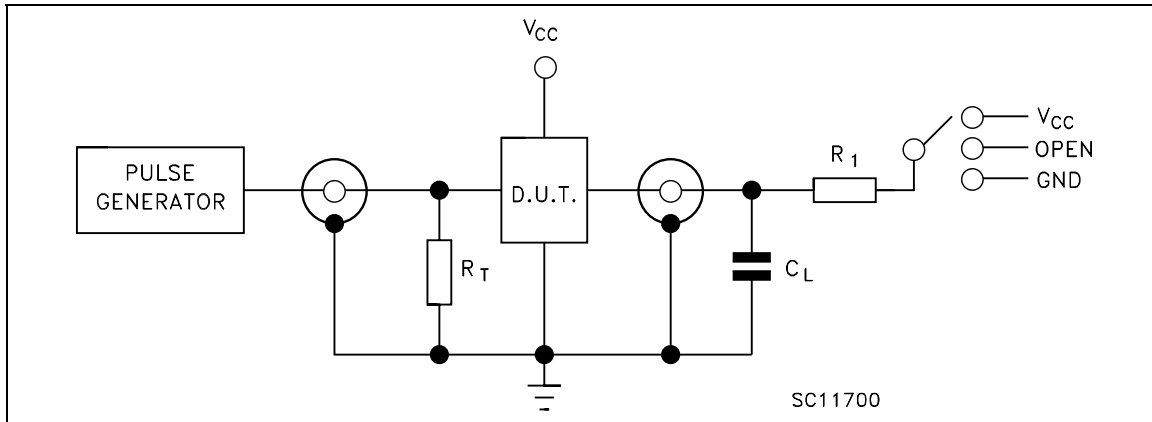

TEST	SWITCH
t_{PLH} , t_{PHL}	Open
t_{PZL} , t_{PLZ}	V_{CC}
t_{PZH} , t_{PHZ}	GND

C_L = 50pF/150pF or equivalent (includes jig and probe capacitance)
 R_1 = 1K Ω or equivalent
 R_T = Z_{OUT} of pulse generator (typically 50 Ω)

WAVEFORM 1: PROPAGATION DELAY TIME (f=1MHz; 50% duty cycle)

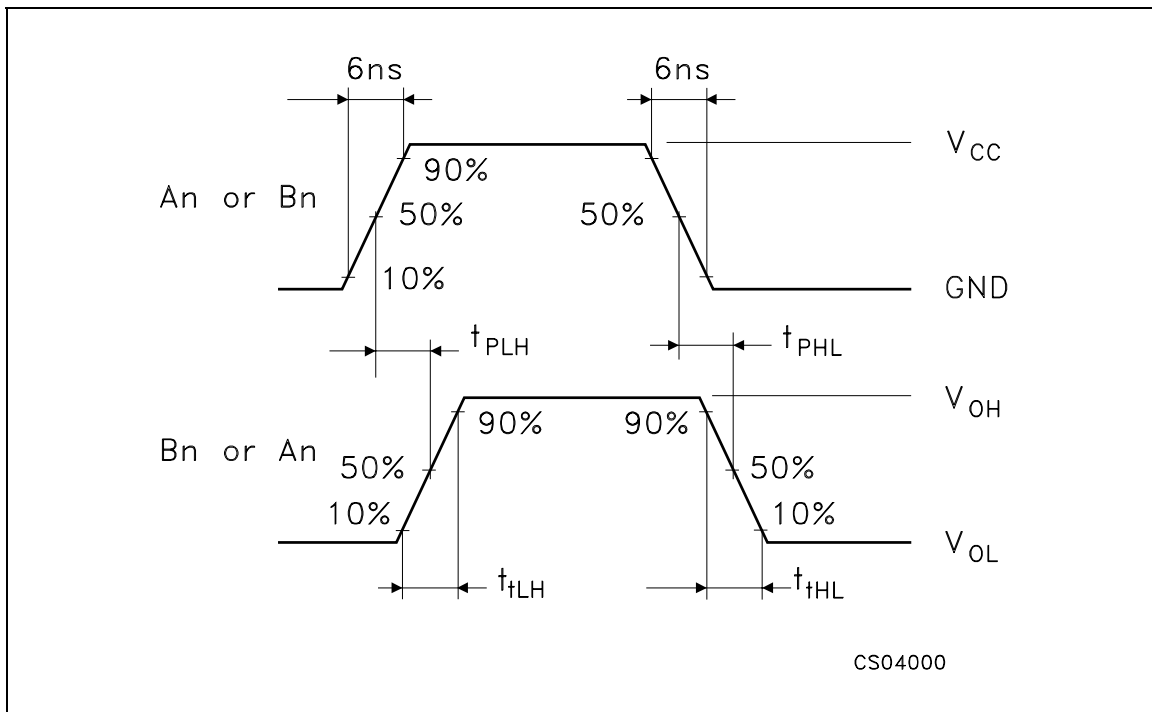

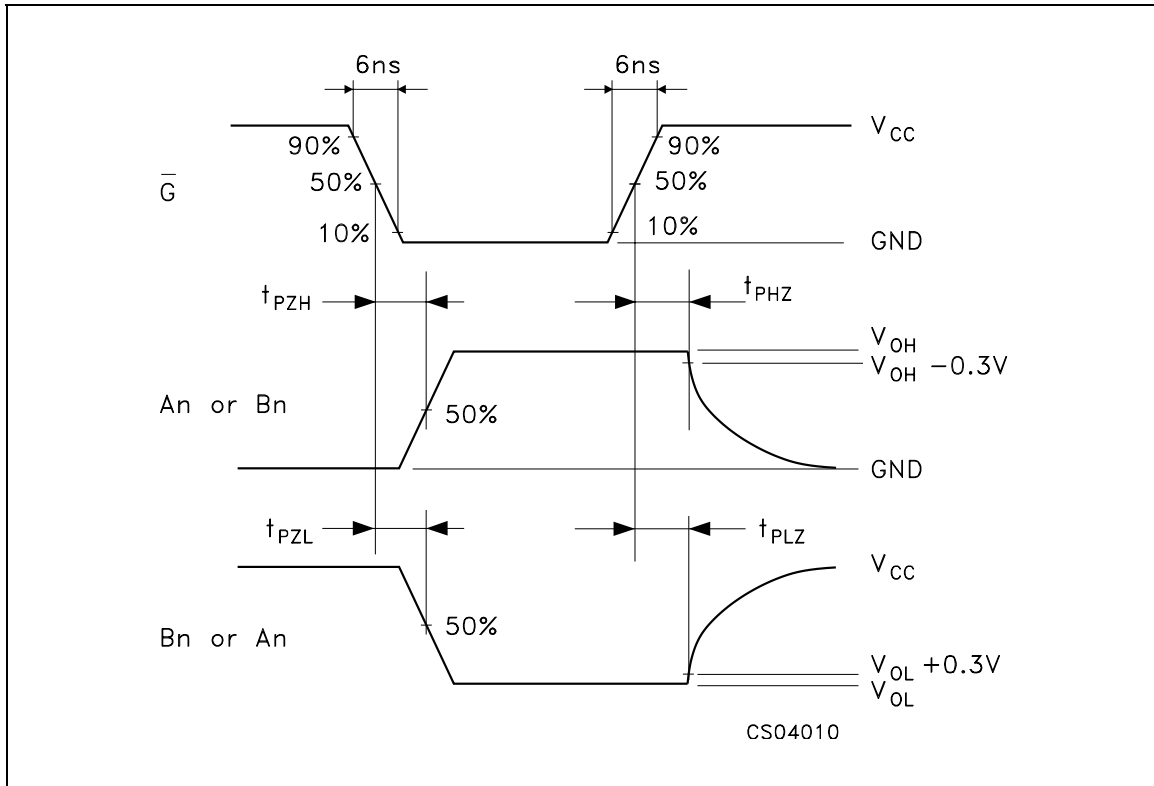
WAVEFORM 2: OUTPUT ENABLE AND DISABLE TIME ($f=1\text{MHz}$; 50% duty cycle)

DILC-20 MECHANICAL DATA

DIM.	mm.			inch		
	MIN.	TYP	MAX.	MIN.	TYP.	MAX.
A	2.1		2.71	0.083		0.107
a1	3.00		3.70	0.118		0.146
a2	0.63	0.88	1.14	0.025	0.035	0.045
B	1.93	2.03	2.23	0.076	0.080	0.088
b	0.40	0.45	0.50	0.016	0.018	0.020
b1	0.20	0.254	0.30	0.008	0.010	0.012
D	25.14	25.40	25.65	0.990	1.000	1.010
e	7.36	7.62	7.87	0.290	0.300	0.310
e1		2.54			0.100	
e2	22.73	22.86	22.99	0.895	0.900	0.905
e3	7.62	7.87	8.12	0.300	0.310	0.320
F	7.29	7.49	7.70	0.287	0.295	0.303
l			3.86			0.152
K	11.30		11.56	0.445		0.455
L	1.14	1.27	1.40	0.045	0.050	0.055

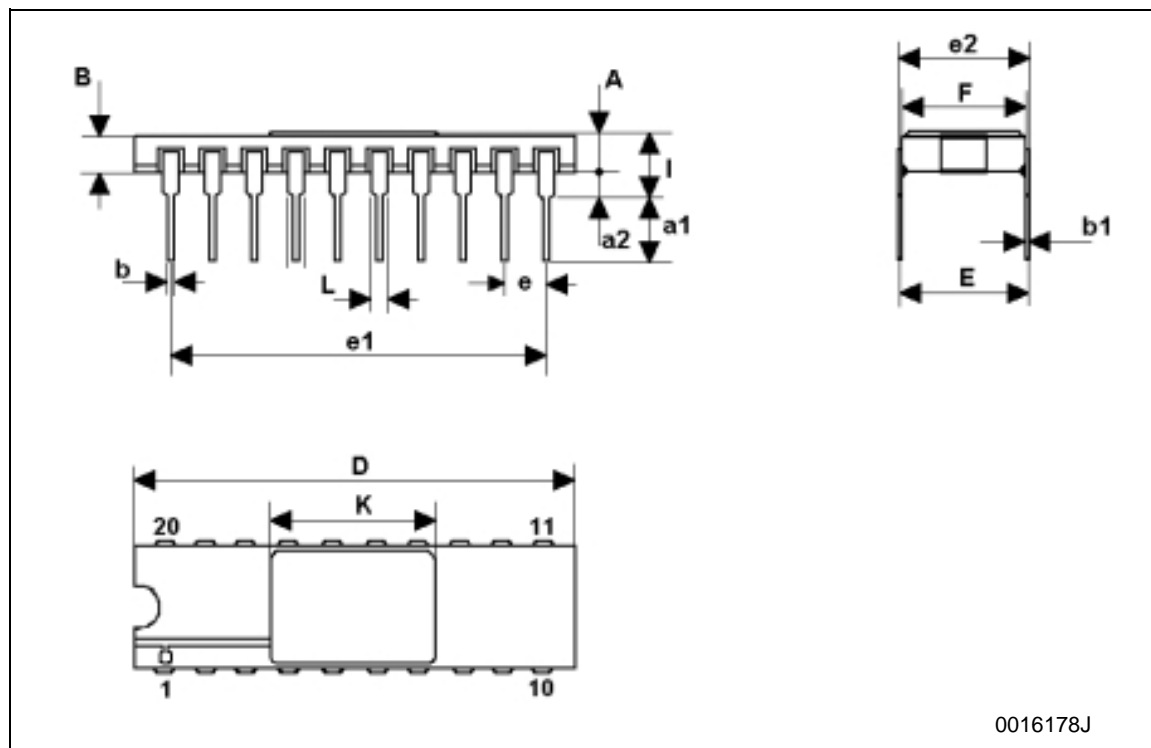

FPC-20 MECHANICAL DATA

DIM.	mm.			inch		
	MIN.	TYP	MAX.	MIN.	TYP.	MAX.
A	9.98	10.16	10.34	0.393	0.400	0.407
B	9.98	10.16	10.34	0.393	0.400	0.407
C	1.45	1.61	1.78	0.57	0.63	0.070
D	0.10	0.127	0.18	0.004	0.005	0.007
E	11.30	11.43	11.56	0.445	0.450	0.455
F		1.27			0.050	
G	0.38	0.43	0.48	0.015	0.017	0.019
H	7.24		8.16	0.285		0.320
L	24.46		26.67	0.960		1.050
M	0.45	0.50	0.55	0.018	0.020	0.022
N		7.87			0.310	
O	1.14	1.27	1.40	0.045	0.050	0.055
P	0.10	0.18	0.25	0.004	0.007	0.010

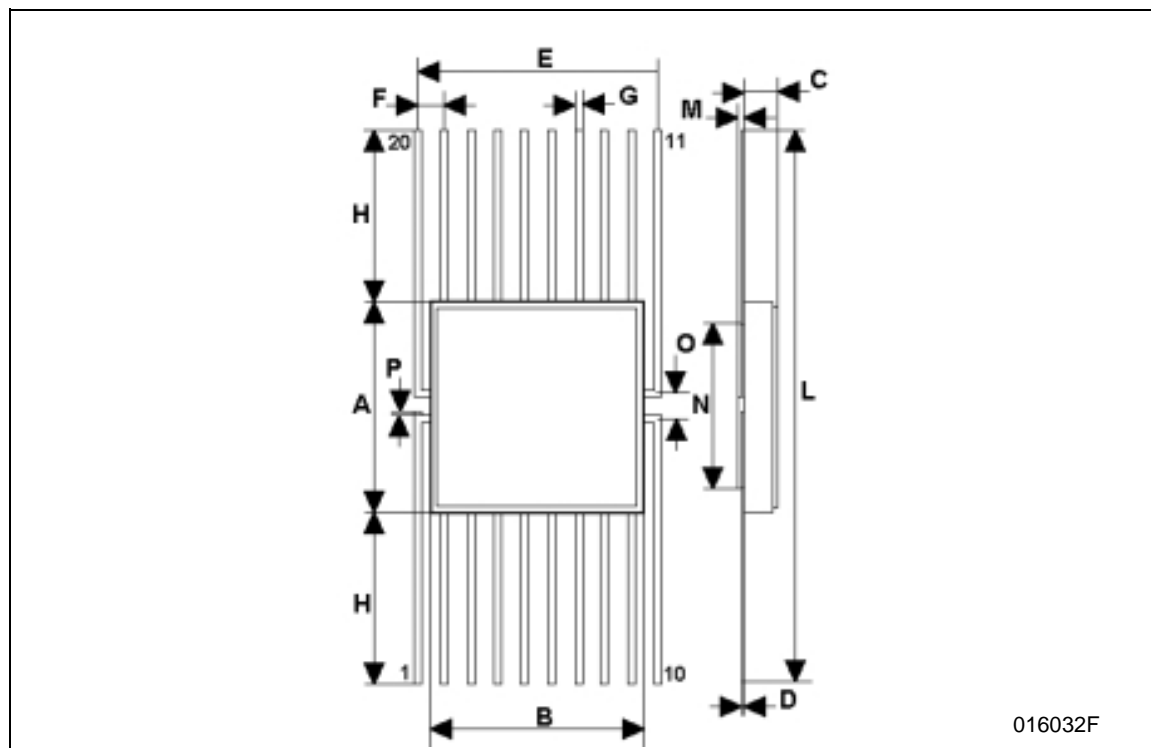

Information furnished is believed to be accurate and reliable. However, STMicroelectronics assumes no responsibility for the consequences of use of such information nor for any infringement of patents or other rights of third parties which may result from its use. No license is granted by implication or otherwise under any patent or patent rights of STMicroelectronics. Specifications mentioned in this publication are subject to change without notice. This publication supersedes and replaces all information previously supplied. STMicroelectronics products are not authorized for use as critical components in life support devices or systems without express written approval of STMicroelectronics.

The ST logo is a registered trademark of STMicroelectronics
All other names are the property of their respective owners

© 2004 STMicroelectronics - All Rights Reserved
STMicroelectronics GROUP OF COMPANIES

Australia - Belgium - Brazil - Canada - China - Czech Republic - Finland - France - Germany - Hong Kong - India - Israel - Italy - Japan - Malaysia - Malta - Morocco - Singapore - Spain - Sweden - Switzerland - United Kingdom - United States.

<http://www.st.com>