

RAD-HARD QUAD D-TYPE FLIP FLOP WITH CLEAR

- HIGH SPEED:
 $t_{PD} = 16 \text{ ns (TYP.) at } V_{CC} = 6V$
- LOW POWER DISSIPATION:
 $I_{CC} = 4\mu\text{A (MAX.) at } T_A = 25^\circ\text{C}$
- HIGH NOISE IMMUNITY:
 $V_{NIH} = V_{NIL} = 28\% V_{CC} \text{ (MIN.)}$
- SYMMETRICAL OUTPUT IMPEDANCE:
 $|I_{OH}| = I_{OL} = 4\text{mA (MIN)}$
- BALANCED PROPAGATION DELAYS:
 $t_{PLH} \cong t_{PHL}$
- WIDE OPERATING VOLTAGE RANGE:
 $V_{CC} \text{ (OPR)} = 2V \text{ to } 6V$
- PIN AND FUNCTION COMPATIBLE WITH 54 SERIES 175
- SPACE GRADE-1: ESA SCC QUALIFIED
- 50 krad QUALIFIED, 100 krad AVAILABLE ON REQUEST
- NO SEL UNDER HIGH LET HEAVY IONS IRRADIATION
- DEVICE FULLY COMPLIANT WITH SCC-9203-052

DESCRIPTION

The M54HC175 is an high speed CMOS HEX D-TYPE FLIP FLOP WITH CLEAR fabricated with silicon gate C²MOS technology.

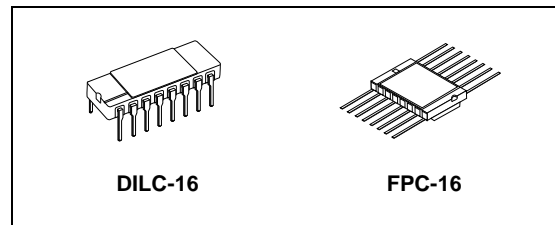

ORDER CODES

PACKAGE	FM	EM
DILC	M54HC175D	M54HC175D1
FPC	M54HC175K	M54HC175K1

These four flip-flops are controlled by a clock input (CLOCK) and a clear input (CLEAR). The information data applied to the D inputs (1D to 4D) are transferred to the outputs (1Q to 4Q and $\overline{1Q}$ to $\overline{4Q}$) on the positive-going edge of the clock pulse. The reset function is accomplished when the CLEAR input is low and all Q outputs are low regardless of other input conditions.

All inputs are equipped with protection circuits against static discharge and transient excess voltage.

PIN CONNECTION

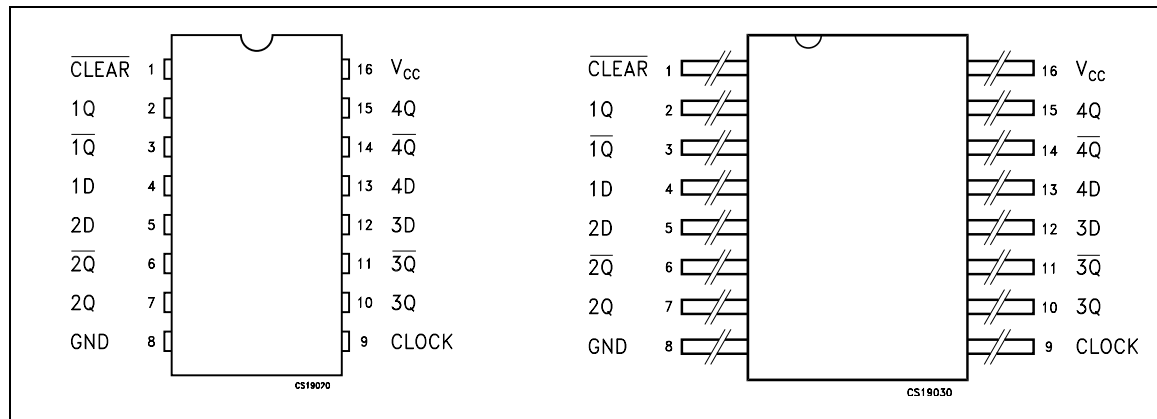

IEC LOGIC SYMBOLS

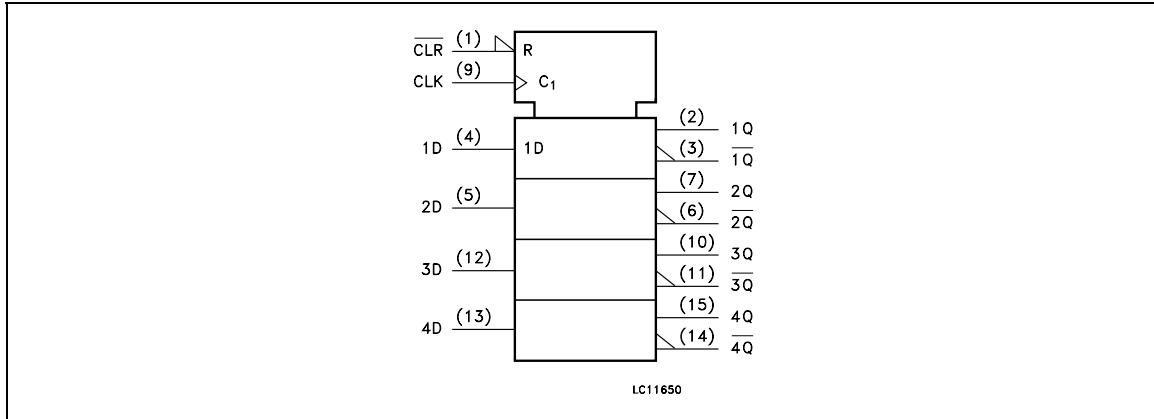

INPUT AND OUTPUT EQUIVALENT CIRCUIT

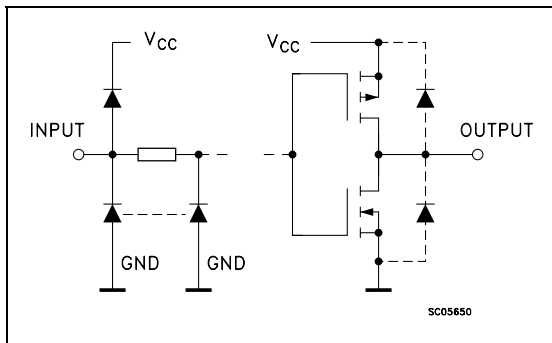

PIN DESCRIPTION

PIN N°	SYMBOL	NAME AND FUNCTION
1	$\overline{\text{CLEAR}}$	Asynchronous Master Reset (Active Low)
2, 7, 10, 15	1Q to 4Q	Flip-Flop Outputs
3, 6, 11, 14	1 $\overline{\text{Q}}$ to 4 $\overline{\text{Q}}$	Complementary Flip-Flop Outputs
4, 5, 12, 13	1D to 4D	Data Inputs
9	CLOCK	Clock Input (LOW to HIGH, edge triggered)
8	GND	Ground (0V)
16	V _{CC}	Positive Supply Voltage

TRUTH TABLE

INPUTS			OUTPUTS		FUNCTION
$\overline{\text{CLEAR}}$	D	CLOCK	Q	$\overline{\text{Q}}$	
L	X	X	L	H	
H	L		L	H	
H	H		H	L	
H	X		Q _n	$\overline{\text{Q}}_n$	NO CHANGE

X : Don't Care

LOGIC DIAGRAM

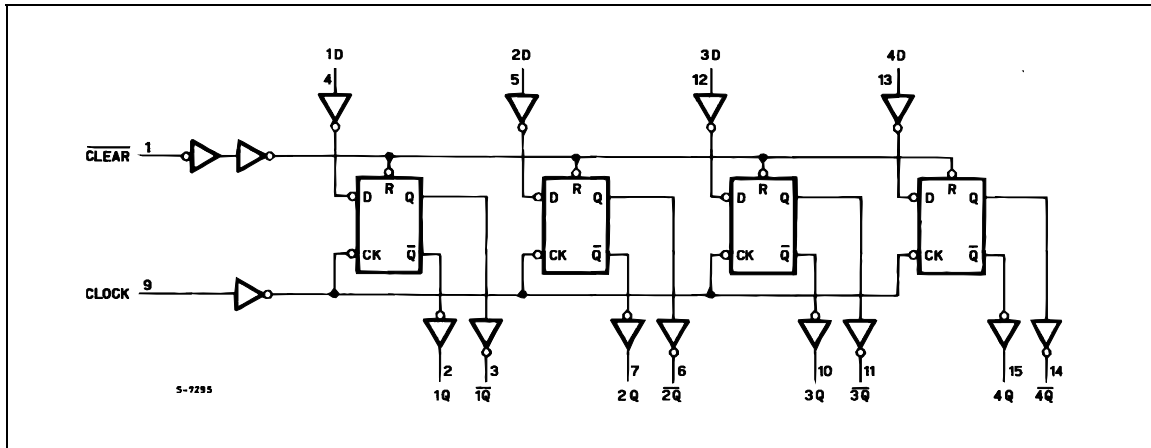

This logic diagram has not be used to estimate propagation delays

ABSOLUTE MAXIMUM RATINGS

Symbol	Parameter	Value	Unit
V_{CC}	Supply Voltage	-0.5 to +7	V
V_I	DC Input Voltage	-0.5 to $V_{CC} + 0.5$	V
V_O	DC Output Voltage	-0.5 to $V_{CC} + 0.5$	V
I_{IK}	DC Input Diode Current	± 20	mA
I_{OK}	DC Output Diode Current	± 20	mA
I_O	DC Output Current	± 25	mA
I_{CC} or I_{GND}	DC V_{CC} or Ground Current	± 50	mA
P_D	Power Dissipation	300	mW
T_{stg}	Storage Temperature	-65 to +150	$^{\circ}C$
T_L	Lead Temperature (10 sec)	265	$^{\circ}C$

Absolute Maximum Ratings are those values beyond which damage to the device may occur. Functional operation under these conditions is not implied

RECOMMENDED OPERATING CONDITIONS

Symbol	Parameter	Value	Unit	
V_{CC}	Supply Voltage	2 to 6	V	
V_I	Input Voltage	0 to V_{CC}	V	
V_O	Output Voltage	0 to V_{CC}	V	
T_{op}	Operating Temperature	-55 to 125	$^{\circ}C$	
t_r, t_f	Input Rise and Fall Time	$V_{CC} = 2.0V$	0 to 1000	ns
		$V_{CC} = 4.5V$	0 to 500	ns
		$V_{CC} = 6.0V$	0 to 400	ns

DC SPECIFICATIONS

Symbol	Parameter	Test Condition		Value						Unit	
		V _{CC} (V)		T _A = 25°C			-40 to 85°C		-55 to 125°C		
				Min.	Typ.	Max.	Min.	Max.	Min.		Max.
V _{IH}	High Level Input Voltage	2.0		1.5			1.5		1.5		V
		4.5		3.15			3.15		3.15		
		6.0		4.2			4.2		4.2		
V _{IL}	Low Level Input Voltage	2.0				0.5		0.5		0.5	V
		4.5				1.35		1.35		1.35	
		6.0				1.8		1.8		1.8	
V _{OH}	High Level Output Voltage	2.0	I _O =-20 μA	1.9	2.0		1.9		1.9		V
		4.5	I _O =-20 μA	4.4	4.5		4.4		4.4		
		6.0	I _O =-20 μA	5.9	6.0		5.9		5.9		
		4.5	I _O =-4.0 mA	4.18	4.31		4.13		4.10		
		6.0	I _O =-5.2 mA	5.68	5.8		5.63		5.60		
V _{OL}	Low Level Output Voltage	2.0	I _O =20 μA		0.0	0.1		0.1		0.1	V
		4.5	I _O =20 μA		0.0	0.1		0.1		0.1	
		6.0	I _O =20 μA		0.0	0.1		0.1		0.1	
		4.5	I _O =4.0 mA		0.17	0.26		0.33		0.40	
		6.0	I _O =5.2 mA		0.18	0.26		0.33		0.40	
I _I	Input Leakage Current	6.0	V _I = V _{CC} or GND			± 0.1		± 1		± 1	μA
I _{CC}	Quiescent Supply Current	6.0	V _I = V _{CC} or GND			4		40		80	μA

AC ELECTRICAL CHARACTERISTICS ($C_L = 50$ pF, Input $t_r = t_f = 6$ ns)

Symbol	Parameter	Test Condition		Value						Unit		
		V_{CC} (V)		$T_A = 25^\circ\text{C}$			-40 to 85°C		-55 to 125°C			
				Min.	Typ.	Max.	Min.	Max.	Min.		Max.	
t_{TLH} t_{THL}	Output Transition Time	2.0			30	75		95		110	ns	
		4.5			8	15		19		22		
		6.0			7	13		16		19		
t_{PLH} t_{PHL}	Propagation Delay Time (CLOCK - Q, \bar{Q})	2.0			60	150		190		225	ns	
		4.5			19	30		38		45		
		6.0			16	26		32		38		
t_{PLH} t_{PHL}	Propagation Delay Time ($\overline{\text{CLEAR}}$ - Q, \bar{Q})	2.0			50	125		155		190	ns	
		4.5			16	25		31		38		
		6.0			14	21		26		32		
f_{MAX}	Maximum Clock Frequency	2.0			6.2	13		5		4.2	MHz	
		4.5			31	52		25		21		
		6.0			37	61		30		25		
$t_{W(H)}$ $t_{W(L)}$	Minimum Pulse Width (CLOCK)	2.0				28	75		95		110	ns
		4.5				7	15		19		22	
		6.0				6	13		16		19	
$t_{W(L)}$	Minimum Pulse Width (CLEAR)	2.0				28	75		95		110	ns
		4.5				7	15		19		22	
		6.0				6	13		16		19	
t_s	Minimum Set-up Time	2.0				28	75		95		110	ns
		4.5				7	15		19		22	
		6.0				6	13		16		19	
t_h	Minimum Hold Time	2.0					0		0		0	ns
		4.5					0		0		0	
		6.0					0		0		0	
t_{REM}	Minimum Removal Time (CLEAR)	2.0					5		5		5	ns
		4.5					5		5		5	
		6.0					5		5		5	

CAPACITIVE CHARACTERISTICS

Symbol	Parameter	Test Condition		Value						Unit		
		V_{CC} (V)		$T_A = 25^\circ\text{C}$			-40 to 85°C		-55 to 125°C			
				Min.	Typ.	Max.	Min.	Max.	Min.		Max.	
C_{IN}	Input Capacitance	5.0				5	10		10		10	pF
C_{PD}	Power Dissipation Capacitance (note 1)	5.0				47						pF

1) C_{PD} is defined as the value of the IC's internal equivalent capacitance which is calculated from the operating current consumption without load. (Refer to Test Circuit). Average operating current can be obtained by the following equation. $I_{CC(opr)} = C_{PD} \times V_{CC} \times f_{IN} + I_{CC}/4$ (per FLIP/FLOP)

TEST CIRCUIT

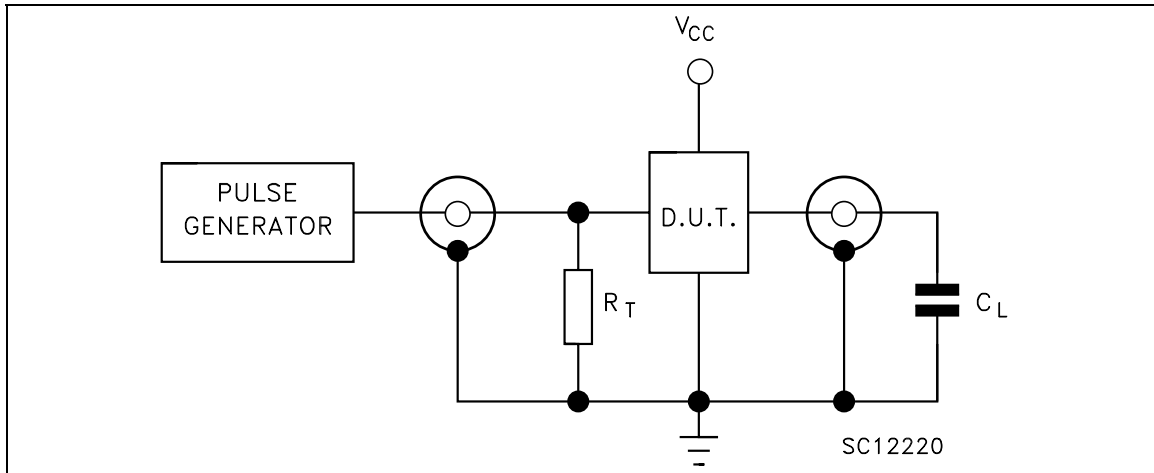

$C_L = 50\text{pF}$ or equivalent (includes jig and probe capacitance)
 $R_T = Z_{OUT}$ of pulse generator (typically 50Ω)

WAVEFORM 1: PROPAGATION DELAY TIMES, MINIMUM PULSE WIDTH (CLOCK), SETUP AND HOLD TIME (D TO CLOCK) ($f=1\text{MHz}$; 50% duty cycle)

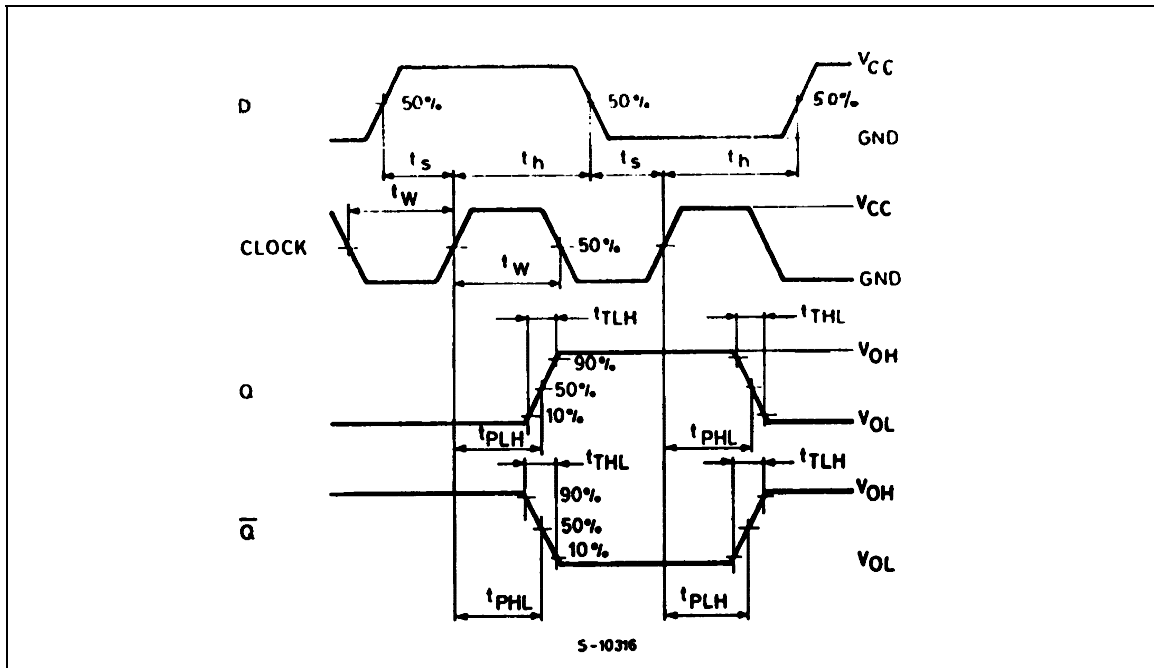

WAVEFORM 2: MINIMUM PULSE WIDTH (CLEAR) AND REMOVAL TIME (CLEAR TO CLOCK)
 (f=1MHz; 50% duty cycle)

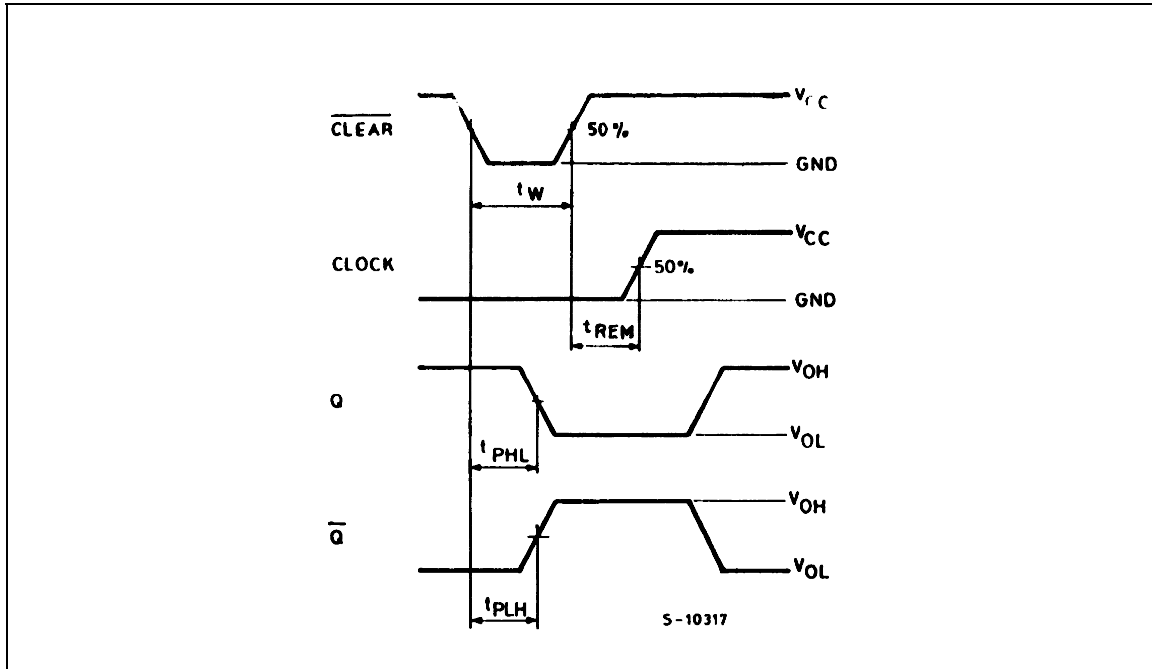

WAVEFORM 3: INPUT WAVEFORMS (f=1MHz; 50% duty cycle)

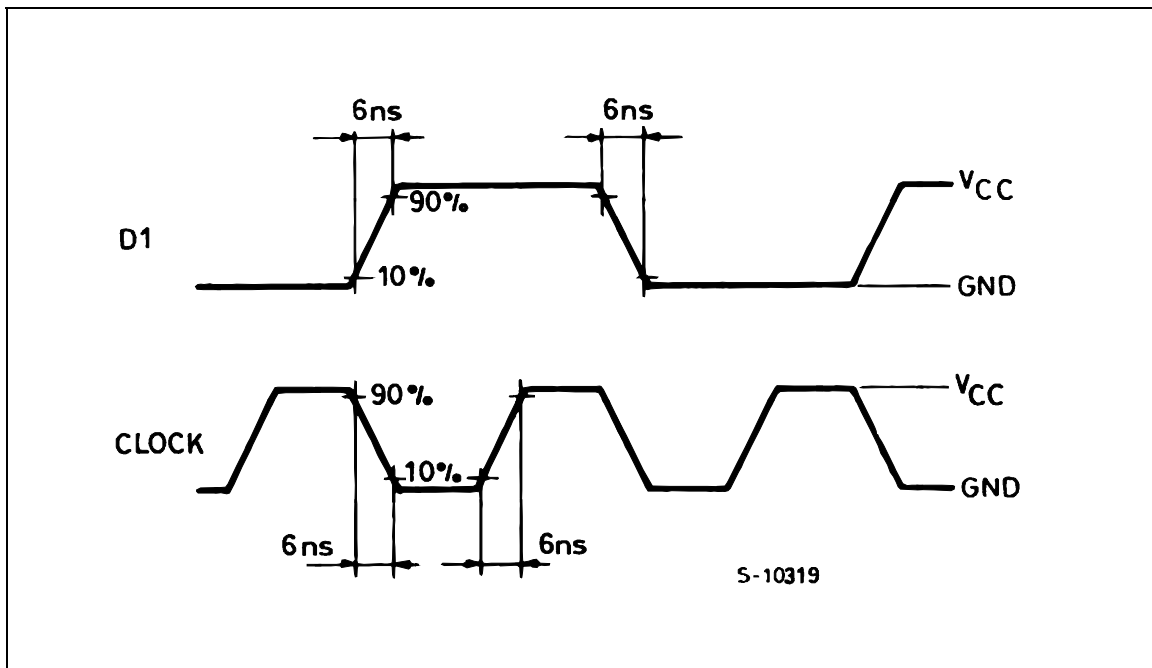

DILC-16 MECHANICAL DATA

DIM.	mm.			inch		
	MIN.	TYP	MAX.	MIN.	TYP.	MAX.
A	2.1		2.71	0.083		0.107
a1	3.00		3.70	0.118		0.146
a2	0.63	0.88	1.14	0.025	0.035	0.045
B	1.82		2.39	0.072		0.094
b	0.40	0.45	0.50	0.016	0.018	0.020
b1	0.20	0.254	0.30	0.008	0.010	0.012
D	20.06	20.32	20.58	0.790	0.800	0.810
e	7.36	7.62	7.87	0.290	0.300	0.310
e1		2.54			0.100	
e2	17.65	17.78	17.90	0.695	0.700	0.705
e3	7.62	7.87	8.12	0.300	0.310	0.320
F	7.29	7.49	7.70	0.287	0.295	0.303
I			3.83			0.151
K	10.90		12.1	0.429		0.476
L	1.14		1.5	0.045		0.059

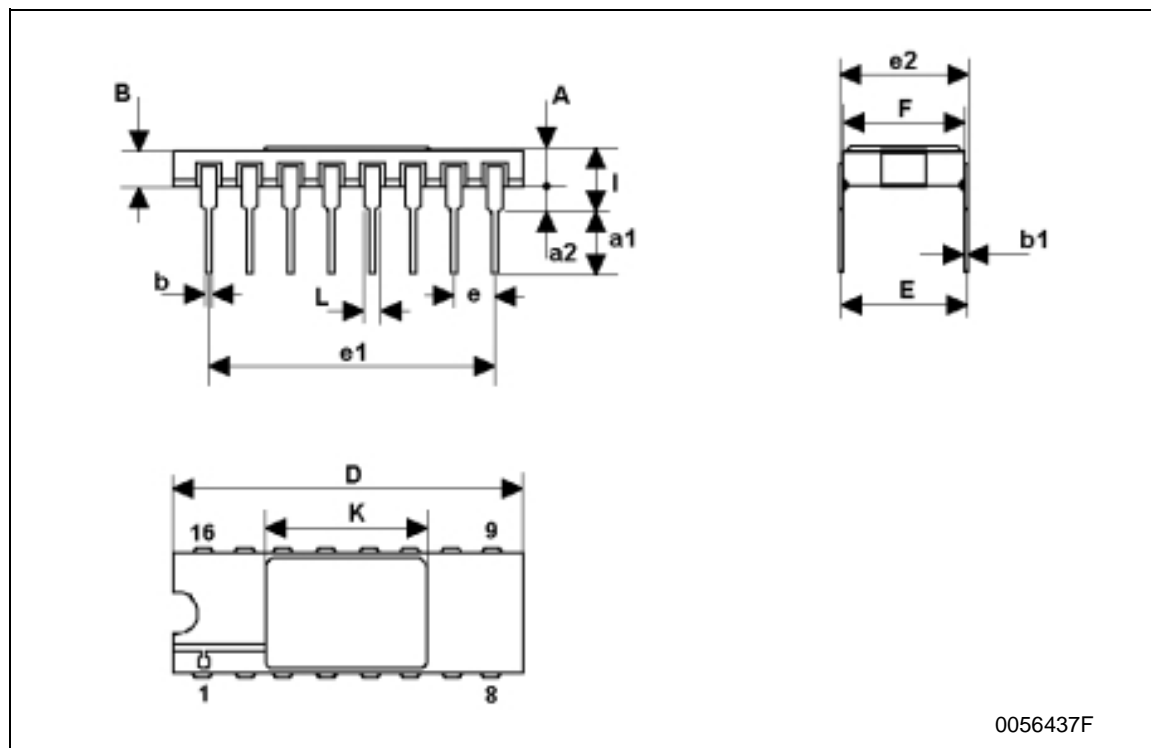

FPC-16 MECHANICAL DATA

DIM.	mm.			inch		
	MIN.	TYP	MAX.	MIN.	TYP.	MAX.
A	6.75	6.91	7.06	0.266	0.272	0.278
B	9.76	9.94	10.14	0.384	0.392	0.399
C	1.49		1.95	0.059		0.077
D	0.102	0.127	0.152	0.004	0.005	0.006
E	8.76	8.89	9.01	0.345	0.350	0.355
F		1.27			0.050	
G	0.38	0.43	0.48	0.015	0.017	0.019
H	6.0			0.237		
L	18.75		22.0	0.738		0.867
M	0.33	0.38	0.43	0.013	0.015	0.017
N		4.31			0.170	

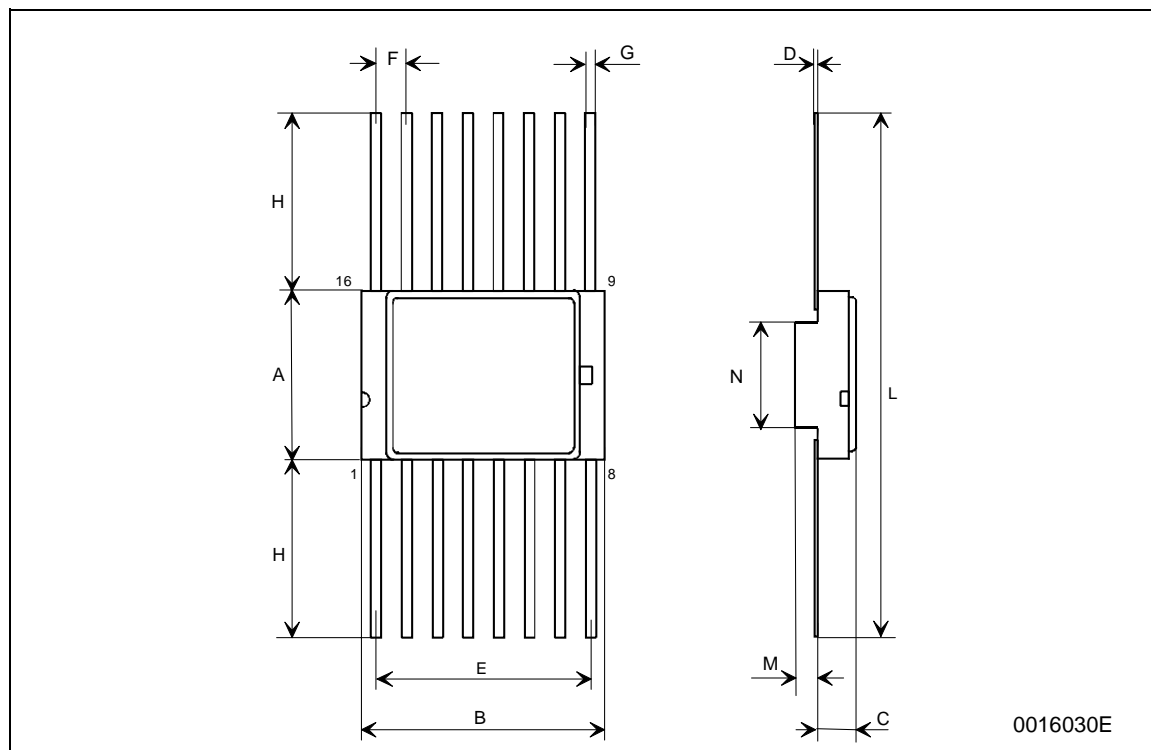

Information furnished is believed to be accurate and reliable. However, STMicroelectronics assumes no responsibility for the consequences of use of such information nor for any infringement of patents or other rights of third parties which may result from its use. No license is granted by implication or otherwise under any patent or patent rights of STMicroelectronics. Specifications mentioned in this publication are subject to change without notice. This publication supersedes and replaces all information previously supplied. STMicroelectronics products are not authorized for use as critical components in life support devices or systems without express written approval of STMicroelectronics.

The ST logo is a registered trademark of STMicroelectronics
All other names are the property of their respective owners

© 2004 STMicroelectronics - All Rights Reserved
STMicroelectronics GROUP OF COMPANIES

Australia - Belgium - Brazil - Canada - China - Czech Republic - Finland - France - Germany - Hong Kong - India - Israel - Italy - Japan - Malaysia - Malta - Morocco - Singapore - Spain - Sweden - Switzerland - United Kingdom - United States.

<http://www.st.com>