

RAD-HARD 3 TO 8 LINE DECODER/LATCH (INVERTING)

- HIGH SPEED:
 $t_{PD} = 18\text{ns}$ (TYP.) at $V_{CC} = 6\text{V}$
- LOW POWER DISSIPATION:
 $I_{CC} = 2\mu\text{A}$ (MAX.) at $T_A = 25^\circ\text{C}$
- HIGH NOISE IMMUNITY:
 $V_{NIH} = V_{NIL} = 28\% V_{CC}$ (MIN.)
- SYMMETRICAL OUTPUT IMPEDANCE:
 $|I_{OH}| = I_{OL} = 4\text{mA}$ (MIN)
- BALANCED PROPAGATION DELAYS:
 $t_{PLH} \approx t_{PHL}$
- WIDE OPERATING VOLTAGE RANGE:
 V_{CC} (OPR) = 2V to 6V
- PIN AND FUNCTION COMPATIBLE WITH
 54 SERIES 137
- SPACE GRADE-1: ESA SCC QUALIFIED
- 50 krad QUALIFIED, 100 krad AVAILABLE ON
 REQUEST
- NO SEL UNDER HIGH LET HEAVY IONS
 IRRADIATION
- DEVICE FULLY COMPLIANT WITH
 SCC-9205-013

DESCRIPTION

The M54HC137 is an high speed CMOS 3 TO 8 LINE DECODER/LATCH (INVERTING) fabricated with silicon gate C²MOS technology. This device is a 3 to 8 line decoder with latches on the three address inputs. When \overline{GL} goes from low

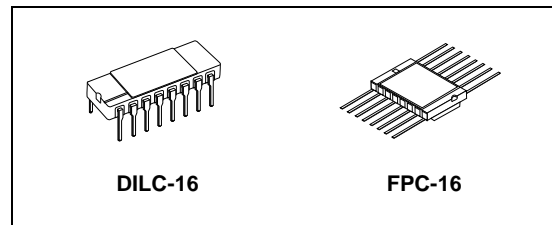

ORDER CODES

PACKAGE	FM	EM
DILC	M54HC137D	M54HC137D1
FPC	M54HC137K	M54HC137K1

to high, the addresses present at the select inputs (A, B, and C) is stored in the latches. As long as \overline{GL} remains high no address changes will be recognized. Output enable pins $\overline{G1}$ and $\overline{G2}$, control the state of the outputs independently of the select or latch-enable inputs. All the outputs are high unless $\overline{G1}$ is high and $\overline{G2}$ is low. The 54HC137 is ideally suited for the implementation of glitch-free decoders in stored-address application in bus oriented systems. All inputs are equipped with protection circuits against static discharge and transient excess voltage.

PIN CONNECTION

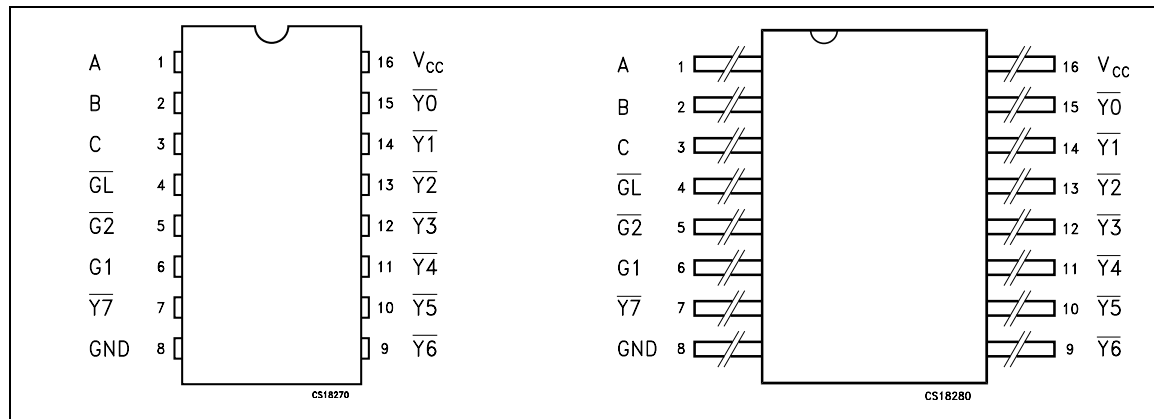

IEC LOGIC SYMBOLS

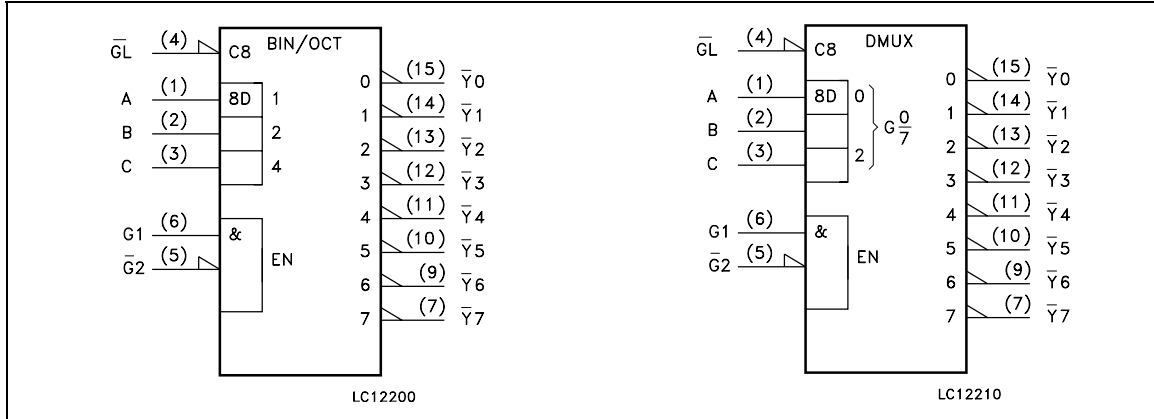

INPUT AND OUTPUT EQUIVALENT CIRCUIT

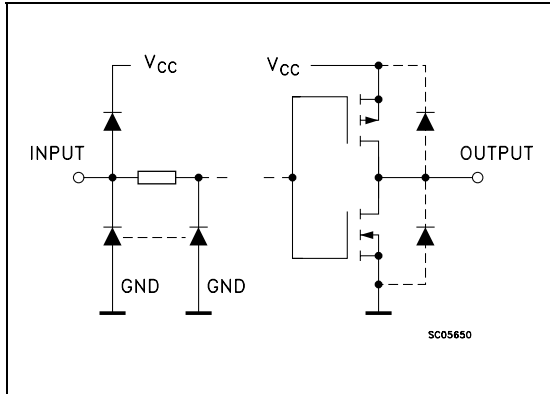

PIN DESCRIPTION

PIN N°	SYMBOL	NAME AND FUNCTION
1, 2, 3	A to C	Data Inputs
4	GL	Latch Enable Input (Active LOW)
5	G2	Data Enable Input (Active LOW)
6	G1	Data Enable Input (Active HIGH)
9, 10, 11, 12, 13, 14, 15, 7	Y0 to Y7	Multiplexer Outputs
8	GND	Ground (0V)
16	V _{CC}	Positive Supply Voltage

TRUTH TABLE

INPUTS						OUTPUTS							
ENABLE			SELECT										
GL	G1	G2	C	B	A	Y0	Y1	Y2	Y3	Y4	Y5	Y6	Y7
X	X	H	X	X	X	H	H	H	H	H	H	H	H
X	L	X	X	X	X	H	H	H	H	H	H	H	H
L	H	L	L	L	L	L	H	H	H	H	H	H	H
L	H	L	L	L	H	H	L	H	H	H	H	H	H
L	H	L	L	H	L	H	H	L	H	H	H	H	H
L	H	L	L	H	H	H	H	H	L	H	H	H	H
L	H	L	H	L	L	H	H	H	H	L	H	H	H
L	H	L	H	H	L	H	H	H	H	H	L	H	H
L	H	L	H	H	H	H	H	H	H	H	H	L	H
L	H	L	H	H	H	H	H	H	H	H	H	H	L
H	H	L	X	X	X	Outputs corresponding to stored address L: all others H							



LOGIC DIAGRAM

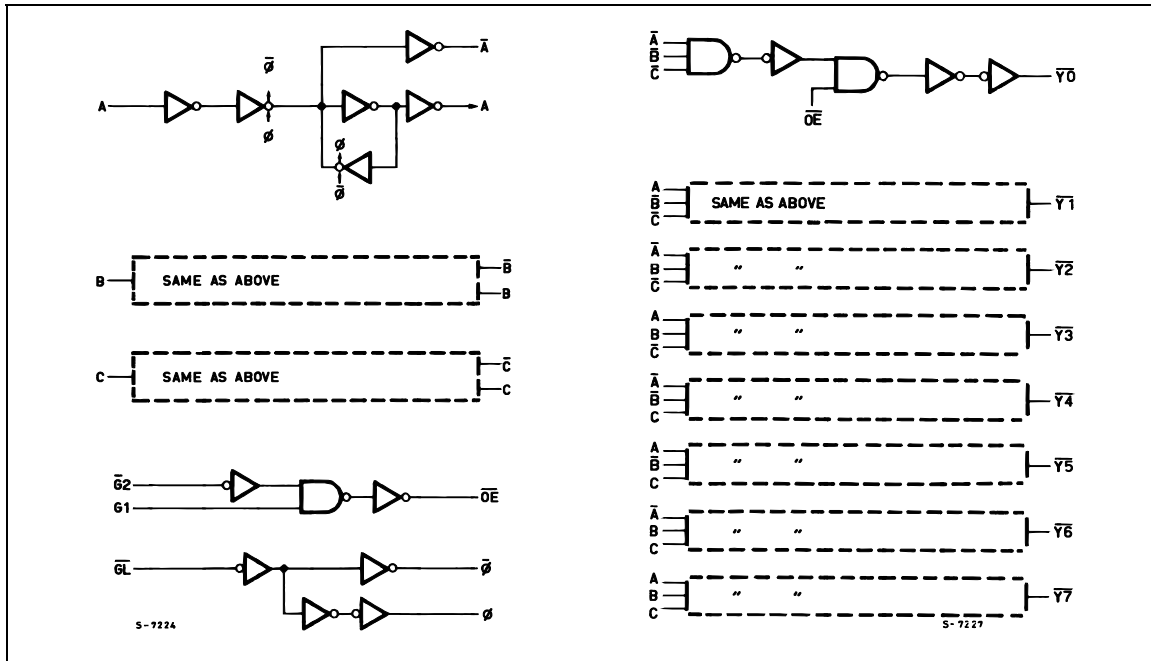

This logic diagram has not be used to estimate propagation delays

ABSOLUTE MAXIMUM RATINGS

Symbol	Parameter	Value	Unit
V_{CC}	Supply Voltage	-0.5 to +7	V
V_I	DC Input Voltage	-0.5 to $V_{CC} + 0.5$	V
V_O	DC Output Voltage	-0.5 to $V_{CC} + 0.5$	V
I_{IK}	DC Input Diode Current	± 20	mA
I_{OK}	DC Output Diode Current	± 20	mA
I_O	DC Output Current	± 25	mA
I_{CC} or I_{GND}	DC V_{CC} or Ground Current	± 50	mA
P_D	Power Dissipation	300	mW
T_{stg}	Storage Temperature	-65 to +150	$^{\circ}C$
T_L	Lead Temperature (10 sec)	265	$^{\circ}C$

Absolute Maximum Ratings are those values beyond which damage to the device may occur. Functional operation under these conditions is not implied

RECOMMENDED OPERATING CONDITIONS

Symbol	Parameter	Value	Unit	
V_{CC}	Supply Voltage	2 to 6	V	
V_I	Input Voltage	0 to V_{CC}	V	
V_O	Output Voltage	0 to V_{CC}	V	
T_{op}	Operating Temperature	-55 to 125	°C	
t_r, t_f	Input Rise and Fall Time	$V_{CC} = 2.0V$	0 to 1000	ns
		$V_{CC} = 4.5V$	0 to 500	ns
		$V_{CC} = 6.0V$	0 to 400	ns

DC SPECIFICATIONS

Symbol	Parameter	Test Condition		Value						Unit	
		V_{CC} (V)		$T_A = 25^\circ\text{C}$			-40 to 85°C		-55 to 125°C		
				Min.	Typ.	Max.	Min.	Max.	Min.		Max.
V_{IH}	High Level Input Voltage	2.0		1.5			1.5		1.5		V
		4.5		3.15			3.15		3.15		
		6.0		4.2			4.2		4.2		
V_{IL}	Low Level Input Voltage	2.0				0.5		0.5		0.5	V
		4.5				1.35		1.35		1.35	
		6.0				1.8		1.8		1.8	
V_{OH}	High Level Output Voltage	2.0	$I_O = -20 \mu\text{A}$	1.9	2.0		1.9		1.9		V
		4.5	$I_O = -20 \mu\text{A}$	4.4	4.5		4.4		4.4		
		6.0	$I_O = -20 \mu\text{A}$	5.9	6.0		5.9		5.9		
		4.5	$I_O = -4.0 \text{ mA}$	4.18	4.31		4.13		4.10		
		6.0	$I_O = -5.2 \text{ mA}$	5.68	5.8		5.63		5.60		
V_{OL}	Low Level Output Voltage	2.0	$I_O = 20 \mu\text{A}$		0.0	0.1		0.1		0.1	V
		4.5	$I_O = 20 \mu\text{A}$		0.0	0.1		0.1		0.1	
		6.0	$I_O = 20 \mu\text{A}$		0.0	0.1		0.1		0.1	
		4.5	$I_O = 4.0 \text{ mA}$		0.17	0.26		0.33		0.40	
		6.0	$I_O = 5.2 \text{ mA}$		0.18	0.26		0.33		0.40	
I_I	Input Leakage Current	6.0	$V_I = V_{CC}$ or GND			± 0.1		± 1		± 1	μA
I_{CC}	Quiescent Supply Current	6.0	$V_I = V_{CC}$ or GND			2		20		40	μA

AC ELECTRICAL CHARACTERISTICS ($C_L = 50 \text{ pF}$, Input $t_r = t_f = 6 \text{ ns}$)

Symbol	Parameter	Test Condition		Value						Unit	
		V_{CC} (V)		$T_A = 25^\circ\text{C}$			$-40 \text{ to } 85^\circ\text{C}$		$-55 \text{ to } 125^\circ\text{C}$		
				Min.	Typ.	Max.	Min.	Max.	Min.		Max.
t_{TLH} t_{THL}	Output Transition Time	2.0			30	75		95		110	ns
		4.5			8	15		19		22	
		6.0			7	13		16		19	
t_{PLH} t_{PHL}	Propagation Delay Time (G1 - Yn)	2.0			45	115		145		175	ns
		4.5			14	23		29		35	
		6.0			12	20		25		30	
t_{PLH} t_{PHL}	Propagation Delay Time (G2 - Yn)	2.0			50	115		145		175	ns
		4.5			15	23		29		35	
		6.0			13	20		25		30	
t_{PLH} t_{PHL}	Propagation Delay Time (GL - Yn)	2.0			70	170		215		250	ns
		4.5			22	34		43		50	
		6.0			19	29		37		43	
t_{PLH} t_{PHL}	Propagation Delay Time (A, B, C - Y)	2.0			70	165		205		110	ns
		4.5			21	33		41		22	
		6.0			18	28		35		19	
$t_{W(H)}$ $t_{W(L)}$	Minimum Pulse Width (GL)	2.0			12	50		65		75	ns
		4.5			3	10		13		15	
		6.0			3	9		11		13	
t_s	Minimum Set-up Time (A, B, C - GL)	2.0			8	50		60		75	ns
		4.5			2	10		12		15	
		6.0			2	9		10		13	
t_h	Minimum Hold Time (A, B, C - GL)	2.0				5		5		5	ns
		4.5				5		5		5	
		6.0				5		5		5	

CAPACITIVE CHARACTERISTICS

Symbol	Parameter	Test Condition		Value						Unit	
		V_{CC} (V)		$T_A = 25^\circ\text{C}$			$-40 \text{ to } 85^\circ\text{C}$		$-55 \text{ to } 125^\circ\text{C}$		
				Min.	Typ.	Max.	Min.	Max.	Min.		Max.
C_{IN}	Input Capacitance	5.0			5	10		10		10	pF
C_{PD}	Power Dissipation Capacitance (note 1)	5.0			55						pF

1) C_{PD} is defined as the value of the IC's internal equivalent capacitance which is calculated from the operating current consumption without load. (Refer to Test Circuit). Average operating current can be obtained by the following equation. $I_{CC(opr)} = C_{PD} \times V_{CC} \times f_{IN} + I_{CC}$

TEST CIRCUIT

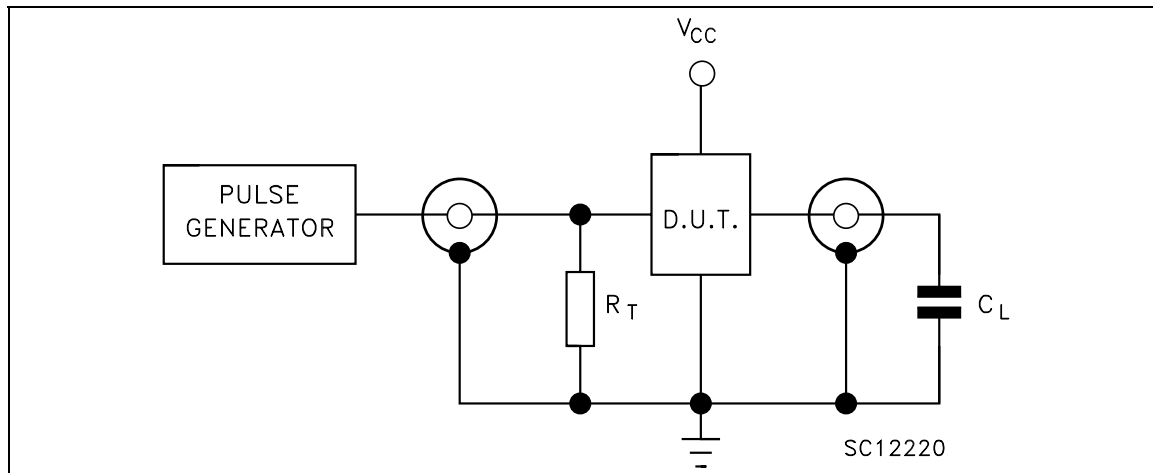

$C_L = 50\text{pF}$ or equivalent (includes jig and probe capacitance)
 $R_T = Z_{OUT}$ of pulse generator (typically 50Ω)

WAVEFORM 1: PROPAGATION DELAY TIME (f=1MHz; 50% duty cycle)

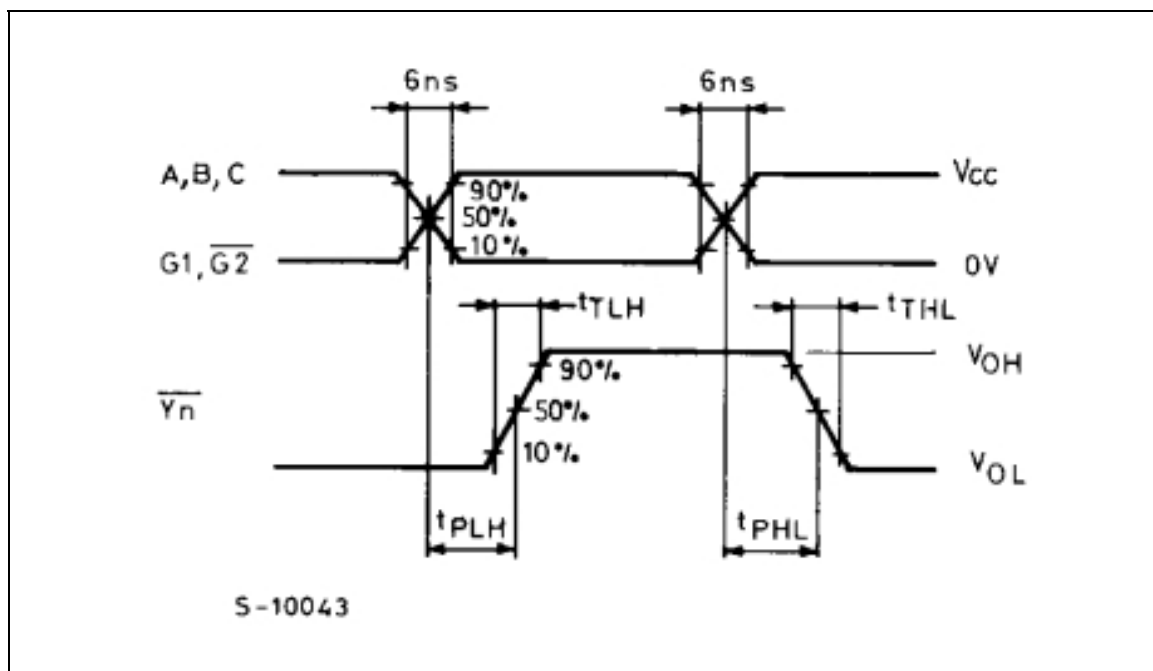

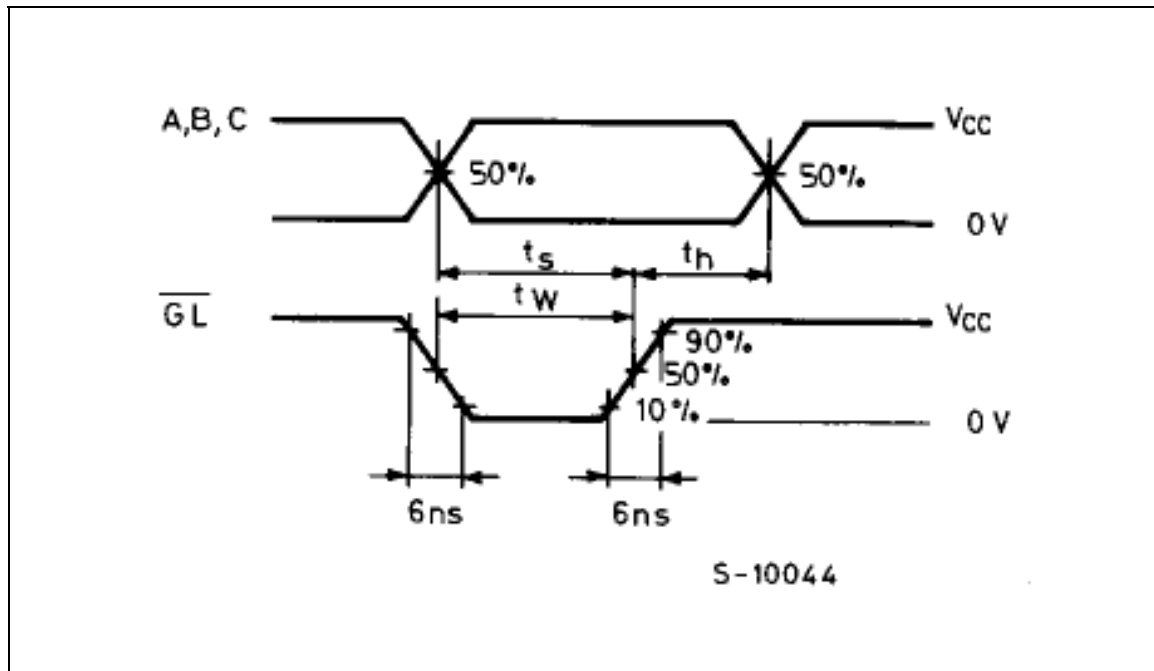
WAVEFORM 2: MINIMUM PULSE WIDTH, SETUP AND HOLD TIME ($f=1\text{MHz}$; 50% duty cycle)

DILC-16 MECHANICAL DATA

DIM.	mm.			inch		
	MIN.	TYP	MAX.	MIN.	TYP.	MAX.
A	2.1		2.71	0.083		0.107
a1	3.00		3.70	0.118		0.146
a2	0.63	0.88	1.14	0.025	0.035	0.045
B	1.82		2.39	0.072		0.094
b	0.40	0.45	0.50	0.016	0.018	0.020
b1	0.20	0.254	0.30	0.008	0.010	0.012
D	20.06	20.32	20.58	0.790	0.800	0.810
e	7.36	7.62	7.87	0.290	0.300	0.310
e1		2.54			0.100	
e2	17.65	17.78	17.90	0.695	0.700	0.705
e3	7.62	7.87	8.12	0.300	0.310	0.320
F	7.29	7.49	7.70	0.287	0.295	0.303
I			3.83			0.151
K	10.90		12.1	0.429		0.476
L	1.14		1.5	0.045		0.059

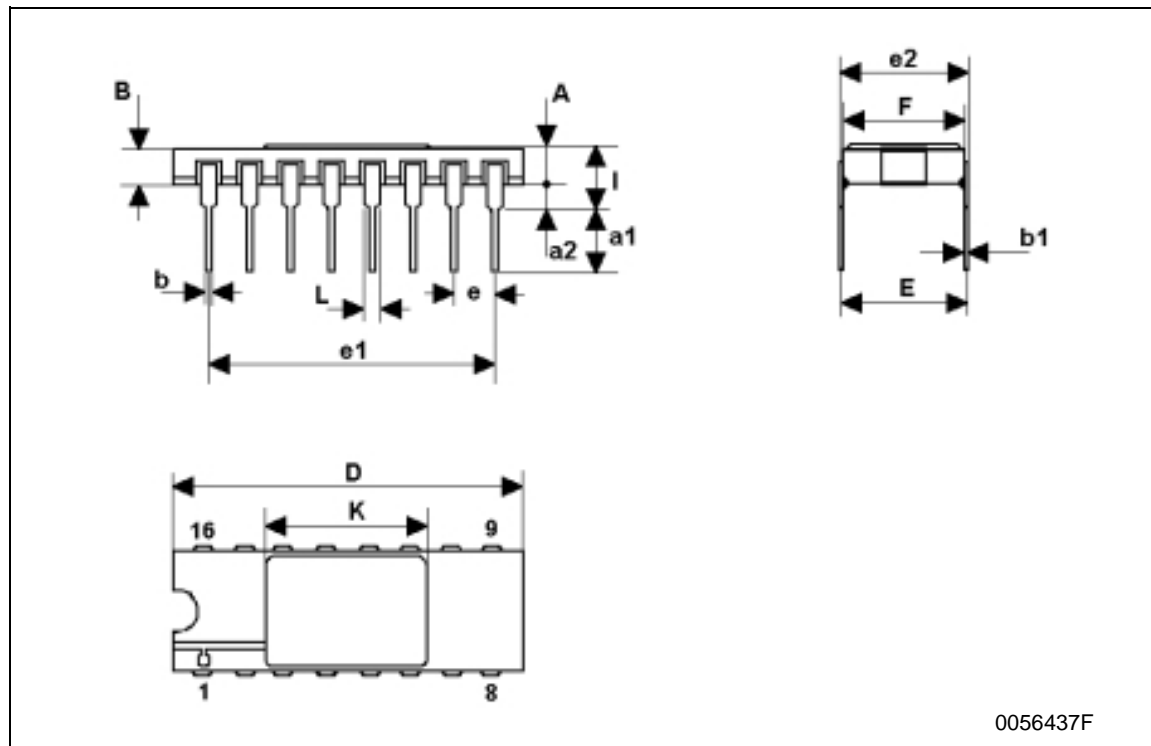

FPC-16 MECHANICAL DATA

DIM.	mm.			inch		
	MIN.	TYP	MAX.	MIN.	TYP.	MAX.
A	6.75	6.91	7.06	0.266	0.272	0.278
B	9.76	9.94	10.14	0.384	0.392	0.399
C	1.49		1.95	0.059		0.077
D	0.102	0.127	0.152	0.004	0.005	0.006
E	8.76	8.89	9.01	0.345	0.350	0.355
F		1.27			0.050	
G	0.38	0.43	0.48	0.015	0.017	0.019
H	6.0			0.237		
L	18.75		22.0	0.738		0.867
M	0.33	0.38	0.43	0.013	0.015	0.017
N		4.31			0.170	

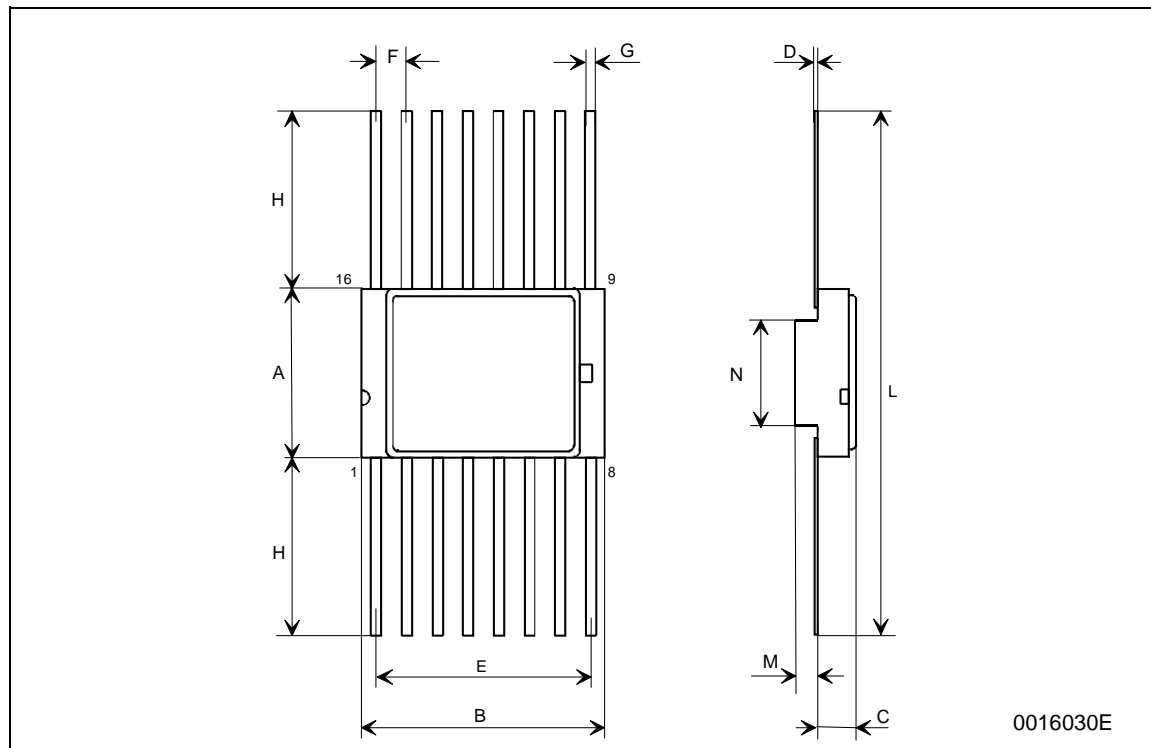

Information furnished is believed to be accurate and reliable. However, STMicroelectronics assumes no responsibility for the consequences of use of such information nor for any infringement of patents or other rights of third parties which may result from its use. No license is granted by implication or otherwise under any patent or patent rights of STMicroelectronics. Specifications mentioned in this publication are subject to change without notice. This publication supersedes and replaces all information previously supplied. STMicroelectronics products are not authorized for use as critical components in life support devices or systems without express written approval of STMicroelectronics.

The ST logo is a registered trademark of STMicroelectronics
All other names are the property of their respective owners

© 2004 STMicroelectronics - All Rights Reserved
STMicroelectronics GROUP OF COMPANIES

Australia - Belgium - Brazil - Canada - China - Czech Republic - Finland - France - Germany - Hong Kong - India - Israel - Italy - Japan - Malaysia - Malta - Morocco - Singapore - Spain - Sweden - Switzerland - United Kingdom - United States.

<http://www.st.com>