

OCTAL BUS TRANSCEIVER

DESCRIPTION

The T54LS245/T74LS245 is an Octal Bus Transceiver intended for 8-line asynchronous 2-way data communication between data buses. Direction Input (DR) takes over the transmission of Data from bus A to bus B or bus B to bus A depending on its logic level. Enable input is usable for isolation of the buses.

- 2-WAY ASYNCHRONOUS DATA BUS COMMUNICATION
- HYSTERESIS INPUTS TO IMPROVE NOISE IMMUNITY
- INPUT DIODES LIMIT HIGH-SPEED TERMINATION EFFECTS

TRUTH TABLE

INPUTS		OUTPUT
\bar{E}	DR	
L	L	Bus B Data to Bus A
L	H	Bus A Data to Bus B
H	X	Isolation

H = HIGH Voltage Level
 L = LOW Voltage Level
 X = Don't Care

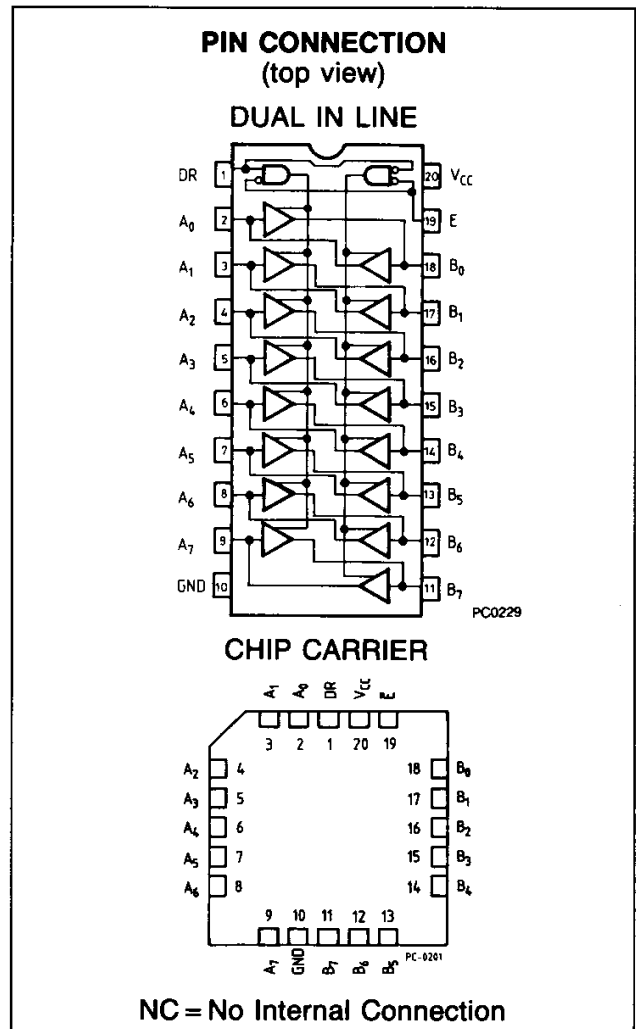
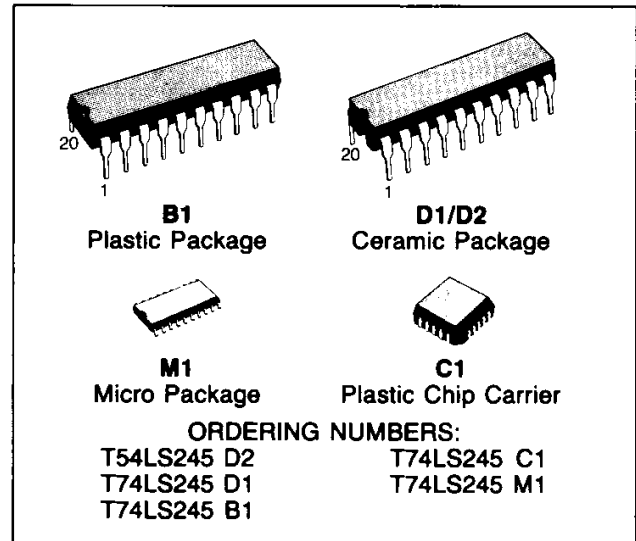

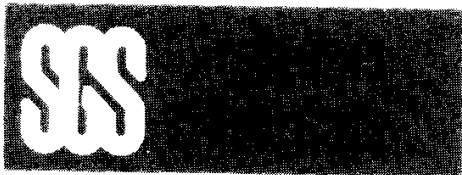

ABSOLUTE MAXIMUM RATINGS

Symbol	Parameter	Value	Unit
V_{CC}	Supply Voltage	-0.5 to 7	V
V_I	Input Voltage, Applied to Input	-0.5 to 15	V
V_O	Output Voltage, Applied to Output	0 to 10	V
I_I	Input Current, Into Inputs	-30 to 5	mA
I_O	Output Current, Into Outputs	50	mA

Stresses in excess of those listed under "Absolute Maximum Ratings" may cause permanent damage to the device. This is a stress rating only and functional operation of the device at these or any other conditions in excess of those indicated in the operational sections of this specification is not implied. Exposure to absolute maximum rating conditions for extended periods may affect device reliability.

GUARANTEED OPERATING RANGES

Part Numbers	Supply Voltage			Temperature
	Min	Typ	Max	
T54LS245D2	4.5 V	5.0 V	5.5 V	-55°C to +125°C
T74LS245XX	4.75 V	5.0 V	5.25 V	0°C to +70°C

XX = package type.

DC CHARACTERISTICS OVER OPERATING TEMPERATURE RANGE

Symbol	Parameter		Limits			Test Conditions (Note 1)	Units
			Min.	Typ.	Max.		
V_{IH}	Input HIGH Voltage		2.0			Guaranteed input HIGH Voltage for all Inputs	V
V_{IL}	Input LOW Voltage	54			0.7	Guaranteed input LOW Voltage for all Inputs	V
		74			0.8		
$V_{T+} - V_{T-}$	Hysteresis		0.2	0.4		$V_{CC} = \text{MIN}$	V
V_{CD}	Input Clamp Diode Voltage			-0.65	-1.5	$V_{CC} = \text{MIN}, I_{IN} = -18\text{mA}$	V
V_{OH}	Output HIGH Voltage	54,74	2.4	3.4		$V_{CC} = \text{MIN}, I_{OH} = -3.0\text{mA}$	V
		54,74	2.0			$I_{OH} = -12\text{mA}$ for 54LS $I_{OH} = -15\text{mA}$ for 74LS $V_{CC} = \text{MIN}$	
V_{OL}	Output LOW Voltage	54,74		0.25	0.4	$I_{OL} = 12\text{mA}$ $I_{OL} = 24\text{mA}$ $V_{CC} = \text{MIN}, V_{IN} = V_{IL}$ or V_{IH} per Truth Table	V
		74		0.35	0.5		
I_{OZH}	Output Off Current HIGH				20	$V_{CC} = \text{MAX}, V_{OUT} = 2.7\text{V}$	μA
I_{OZL}	Output Off Current LOW				-200	$V_{CC} = \text{MAX}, V_{OUT} = 0.4\text{V}$	μA
I_{IH}	Input HIGH Current A or B, DR or \bar{E} DR or \bar{E} A or B				20	$V_{CC} = \text{MAX}, V_{IN} = 2.7\text{V}$	μA
					0.1	$V_{CC} = \text{MAX}, V_{IN} = 7.0\text{V}$	mA
					0.1	$V_{CC} = \text{MAX}, V_{IN} = 5.5\text{V}$	mA
I_{IL}	Input LOW Current				-0.2	$V_{CC} = \text{MAX}, V_{IN} = 0.4\text{V}$	mA
I_{OS}	Output Short Circuit Current		-40		-225	$V_{CC} = \text{MAX}$ (Note 2)	mA
I_{CC}	Power Supply Current Total, Output HIGH Total, Output LOW Total at HIGH Z				70	$V_{CC} = \text{MAX}$	mA
					90		
					95		

Notes:

- 1) For conditions shown as MIN or MAX, use the appropriate value specified under guaranteed operating ranges.
- 2) Not more than one output should be shorted at a time.
- 3) Typical values are at $V_{CC} = 5.0\text{V}$, $T_A = 25^\circ\text{C}$

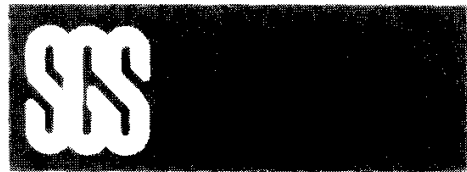
**AC CHARACTERISTICS: $T_A = 25^\circ\text{C}$**

Symbol	Parameter	Limits			Test Conditions	Units
		Min.	Typ.	Max.		
t_{PLH} t_{PHL}	Propagation Delay, Data to Output		8.0 8.0	12 12	$C_L = 45\text{pF}$ $R_L = 667\Omega$	ns
t_{PZH}	Output Enable Time to HIGH Level		25	40		ns
t_{PZL}	Output Enable Time to LOW Level		27	40		ns
t_{PLZ}	Output Disable Time from LOW Level		15	25	$C_L = 5.0\text{pF}$	ns
t_{PHZ}	Output Disable Time from HIGH Level		15	25		ns

14-LEAD PLASTIC DIP

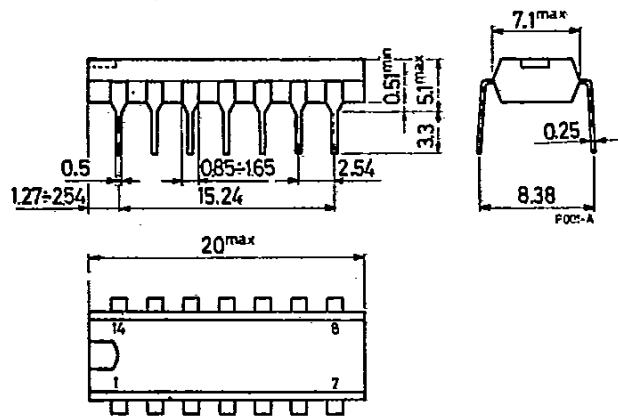
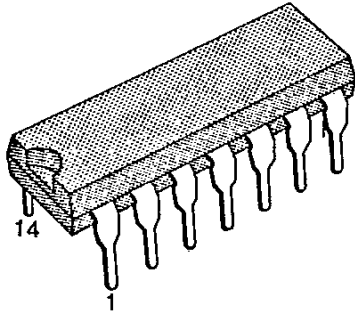

14-LEAD CERAMIC DIP

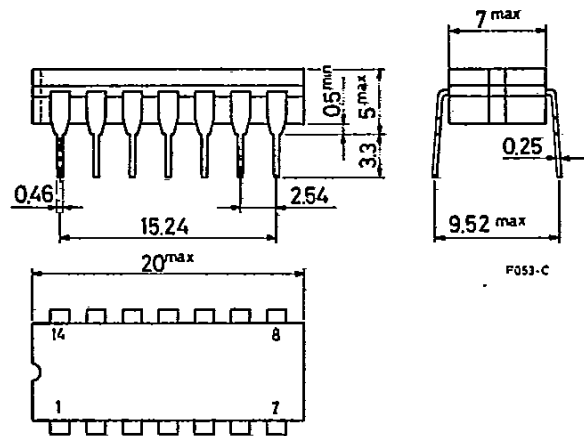
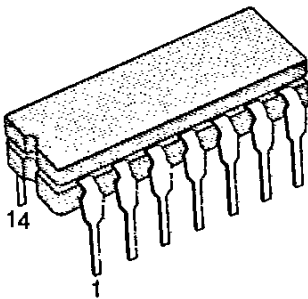

16-LEAD PLASTIC DIP

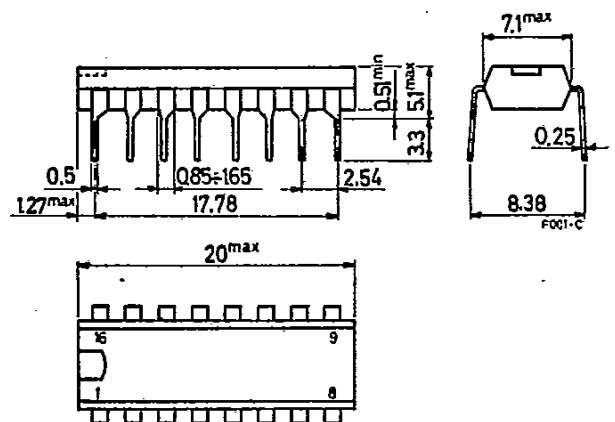
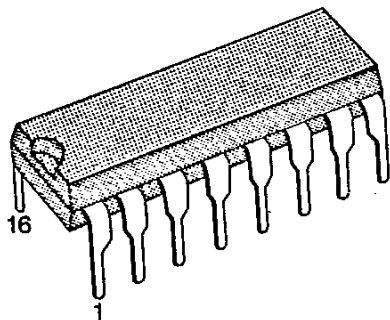

16-LEAD CERAMIC DIP

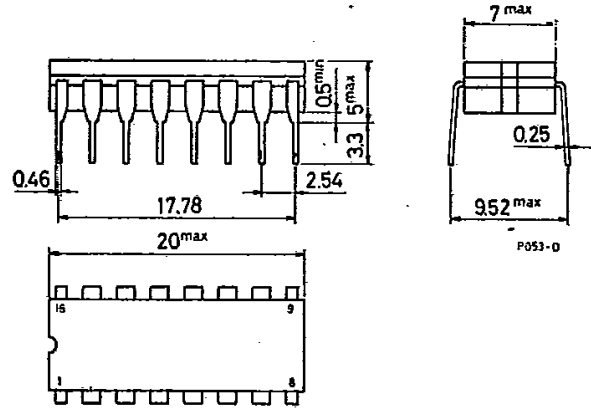
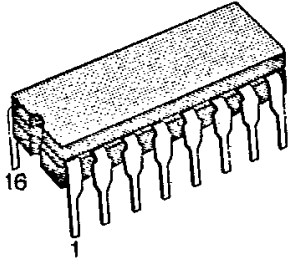

20-LEAD PLASTIC DIP

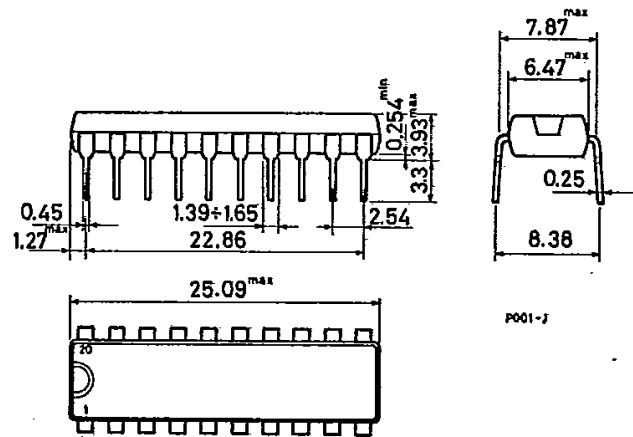
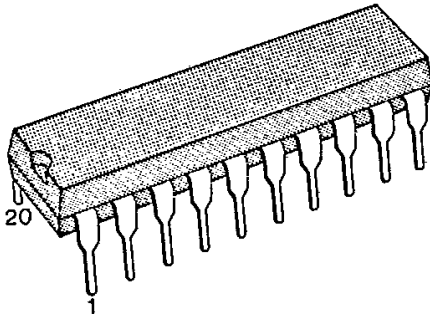

20-LEAD CERAMIC DIP

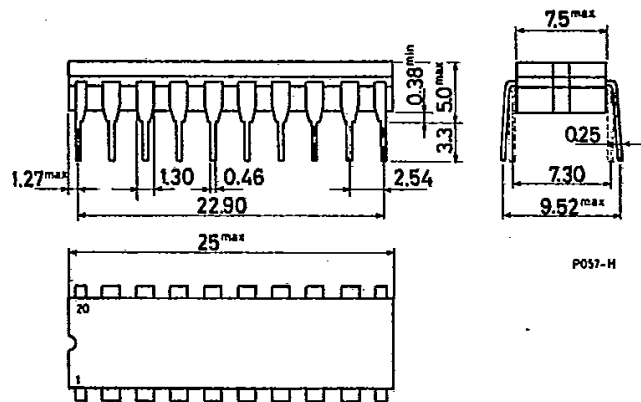
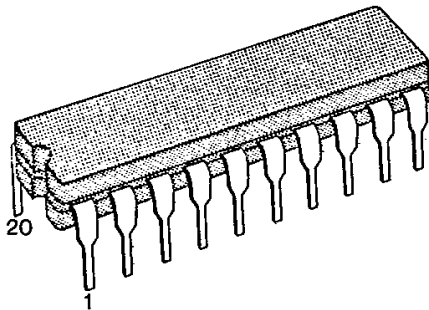

24-LEAD PLASTIC DIP

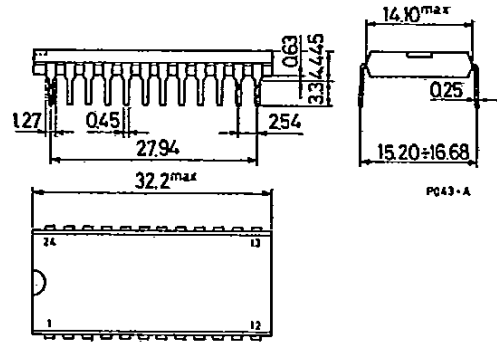
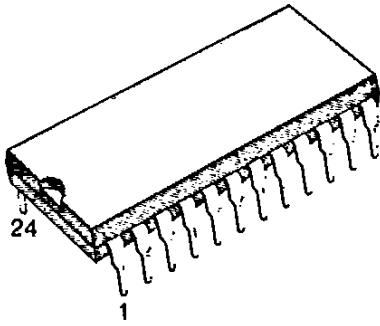

24-LEAD CERAMIC DIP

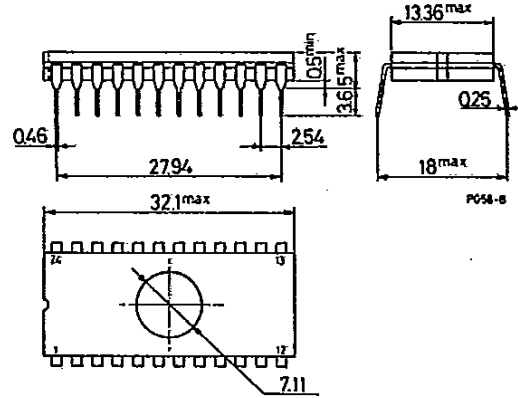
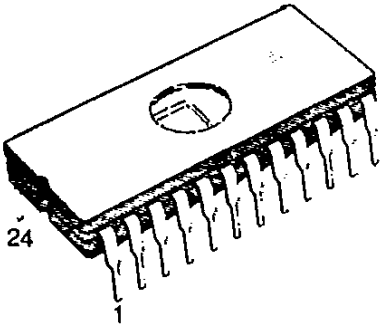

CHIP CARRIER 20 LEAD PLASTIC

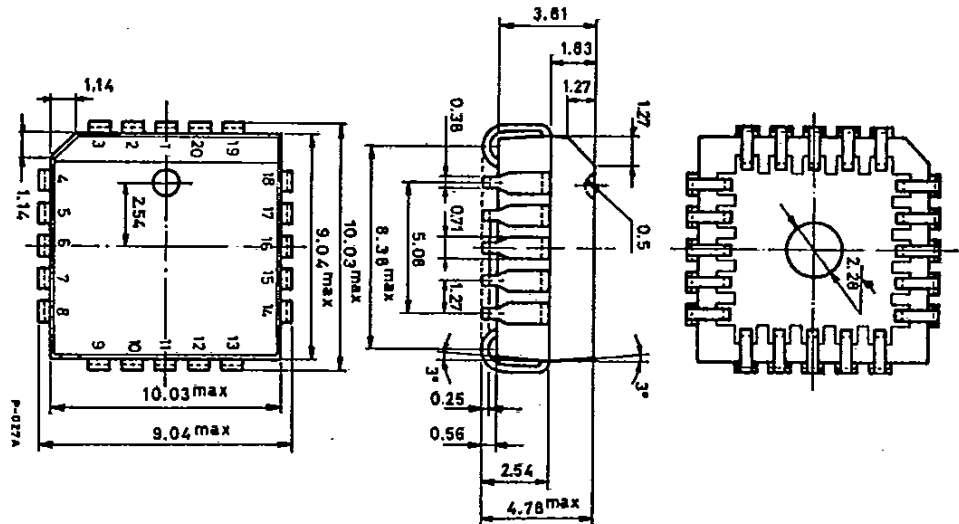
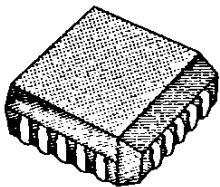

0608

B-01

583

7

14-LEAD PLASTIC DIP MICROPACKAGE

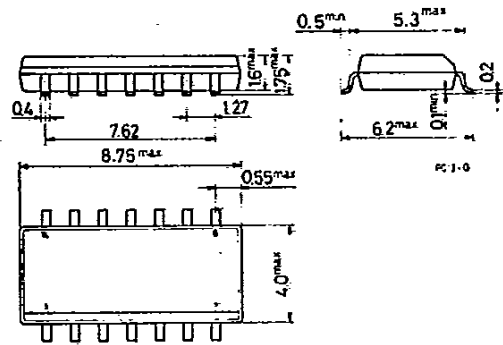
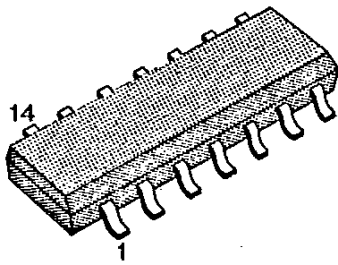

16-LEAD PLASTIC DIP MICROPACKAGE

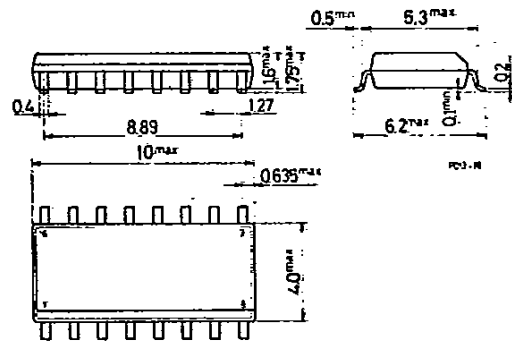
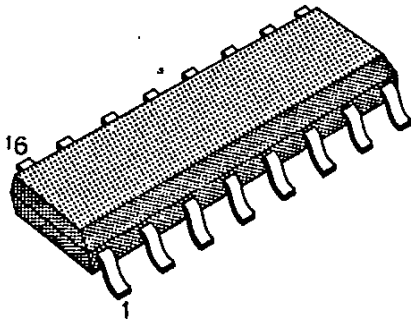

NOTE: FOR 20-LEAD PLASTIC DIP MICROPACKAGE CONTACT SGS

One possible solution to the important problem of PWB minimization, is that of using surface mounted components. Integrated circuits in SO (Small Outline) packages are made up of standard chips mounted in very small plastic packages. The advantages given by using these devices are:

PWB Reduction

This is by far the most important advantage since the reduction of PWB size varies from 40 to 60% in comparison with standard board types. (See page 584 for package dimensions.)

Assembly Cost Reduction

SO Devices require no preliminary operation prior to mounting and can therefore be easily utilized in fully automatic equipment.

Increasing Reliability

The following characteristics lead to a higher level of reliability with respect to their standard packaged counter parts:

- The mounting system is fully automatic
- PWB number and the interconnections between them are reduced when the same number of devices are used.
- The high density of components on the board makes it thermally much more stable.

Noise Reduction and Improved Frequency Response

The reduction of the length of the connecting wires between the leads and the silicon guarantees a more homogeneous propagation delay between the external pins, with respect to the standard type.

Assembly Without Board Holes

The devices are placed on the board and soldered. This technology permits a higher level of tolerance in the positioning (automatic) of the device. For the standard DIP types this must be done with great accuracy due to the insertion of the leads into their holes.

