



Endicott Research Group, Inc.

2601 Wayne St., Endicott, NY 13760

607-754-9187 Fax 607-754-9255

http://www.ergpower.com

Specifications and Applications Information

08/09/07

Preliminary

The ERG DMD43547 (DMD Series) DC to AC inverter features onboard connectors and can be easily dimmed using the onboard PWM Dimming or an external PWM generator.

Powered by a regulated +12 Volt DC source, the DMD43547 is designed to power the backlight of the Optrex T-55105D121J-FW-A-AAN.

Product Features

- ✓ Small Package Size
- ✓ High Dimming Ratio
- ✓ High Efficiency
- ✓ Made in U.S.A.

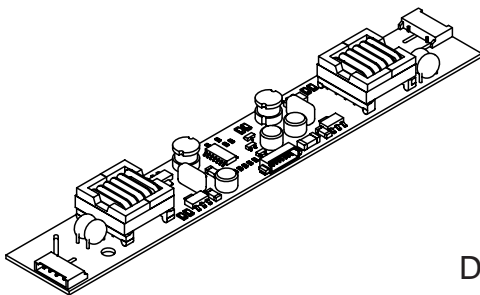

DMD Package

PCB components are shown for reference only. Actual product may differ from that shown.

Connectors

Output (J2,J3)
JST SM04(4.0)B-BHS-1-TB

Input (J1)
Molex 53261-0871

DMD43547

Four Lamp DC to AC Inverter

Package Configuration

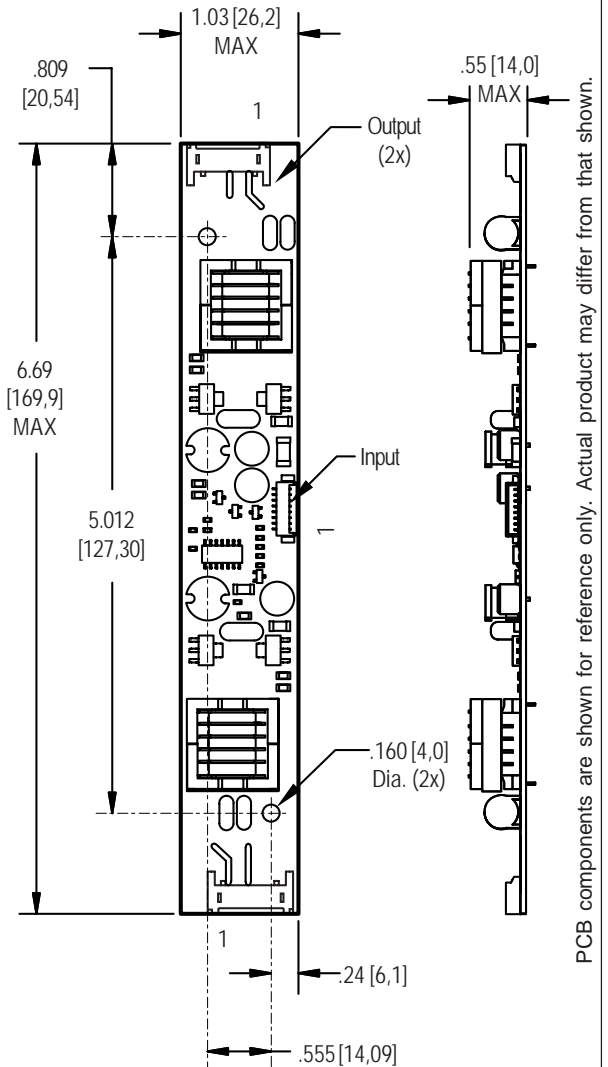

PCB components are shown for reference only. Actual product may differ from that shown.

Mass: 45 grams

Pin Descriptions

J2-1 ACout	J1-1 Vin	J3-1 ACout
J2-2 ACout	J1-2 Vin	J3-2 ACout
J2-3 ACreturn	J1-3 GND	J3-3 ACreturn
J2-4 ACreturn	J1-4 GND	J3-4 ACreturn
	J1-5 Enable	
	J1-6 Control	
	J1-7 GND	
	J1-8 GND	

**Absolute Maximum Ratings**

Rating	Symbol	Value	Units
Input Voltage Range	V_{in}	-0.3 to +13.2	Vdc
Storage Temperature	T_{stg}	-40 to +85	°C

Operating Characteristics

With a load simulating the referenced display and lamp warm-up of 5 minutes.
Unless otherwise noted $V_{in} = 12.00$ Volts dc and $T_a = 25^{\circ}\text{C}$.

Characteristic	Symbol	Min	Typ	Max	Units
Input Voltage	V_{in}	+10.8	+12.0	+12.6	Vdc
Component Surface Temperature ^(note 2)	T_s	-20	-	+80	°C
Input Current ^(note 1)	I_{in}	-	1.34	1.55	Adc
Input Ripple Current	I_{rip}	-	20	-	mA _{pk-pk}
Operating Frequency	F_o	35	40	45	kHz
Minimum Output Voltage ^(note 3)	$V_{out}(\text{min})$	1400	-	-	Vrms
Efficiency	η	-	87	-	%
Output Current (per lamp)	I_{out}	-	6.5	-	mArms
Output Voltage	V_{out}	-	540	-	Vrms
Enable Pin					
Turn-off Threshold	V_{thoff}	GND	-	0.5	Vdc
Turn-on Threshold	V_{thon}	2.5	-	V_{in}	Vdc
Impedance to V_{in}	R_{Enable}	9.5	10.0	10.5	kOhms

Specifications subject to change without notice.

(Note 1) Input current in excess of maximum may indicate a load/inverter mismatch condition, which can result in reduced reliability. Please contact ERG technical support.

(Note 2) Surface temperature must not exceed 80 degrees C; thermal management actions may be required.

(Note 3) Provided data is not tested but guaranteed by design.

Application Notes:

- 1) The minimum distance from high voltage areas of the inverter to any conductive material should be .12 inches per kilovolt of starting voltage.
- 2) Mounting hardware to be non-conductive.
- 3) Open framed inverters should not be used in applications at altitudes over 10,000 feet.
- 4) Contact ERG for possible exceptions.



Onboard PWM

Unless otherwise noted $V_{in} = 12.00$ Volts DC, $T_a = 25$ °C and unit has been running for 5 minutes.

Characteristic	Symbol	Min	Typ	Max	Units
Frequency	f_{pwm}	-	160	-	Hz
Control Input Bias Current	I_{cbias}	-	-	10	uA

Pin Descriptions

- Vin** Input voltage to the inverter. The two pins should be connected for optimum reliability and efficiency.
- GND** Inverter ground. The four pins should be connected for optimum reliability and efficiency.
- Control** Analog voltage input to the onboard pulse width modulator. Decreasing this voltage increases the ON time of the onboard PWM resulting in increased brightness. The inverter is full ON when this voltage is near inverter ground.
- Enable** Inverter Enable. Pull this pin low to disable inverter operation. This pin must be high to enable the inverter. The onboard PWM is always utilized.

Application information

The DMD series of inverters is designed to power up to four cold cathode fluorescent lamps. An external analog control interfaces with an onboard pulse width modulator to provide dimming control. The DMD inverter can reliably dim to less than 5% duty cycle.

External shutdown of the inverter is accomplished using the Enable pin. Pulling this pin low (below V_{thoff}) disables the inverter. Enabling the inverter is accomplished by pulling this pin high (above V_{thon}).

If analog voltage dimming is required, the analog voltage is applied to the Control pin. Figure 1 shows how to connect the inverter for onboard PWM operation. Graph 1 shows the relationship of PWM duty cycle to input control voltage.

If an external PWM is used, connect the Enable pin to the PWM source and connect the Control pin to inverter Ground. If the onboard PWM is used, connect the analog voltage to the Control pin.

Low ESR type input by-pass capacitor (22uF - 100uF) may be required to reduce reflected ripple.

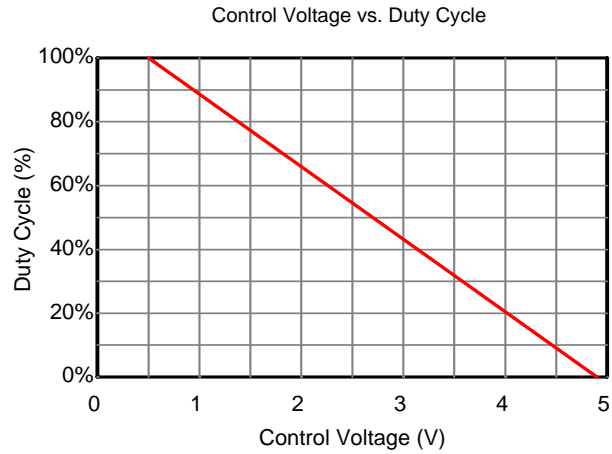

Graph 1

Typical Application

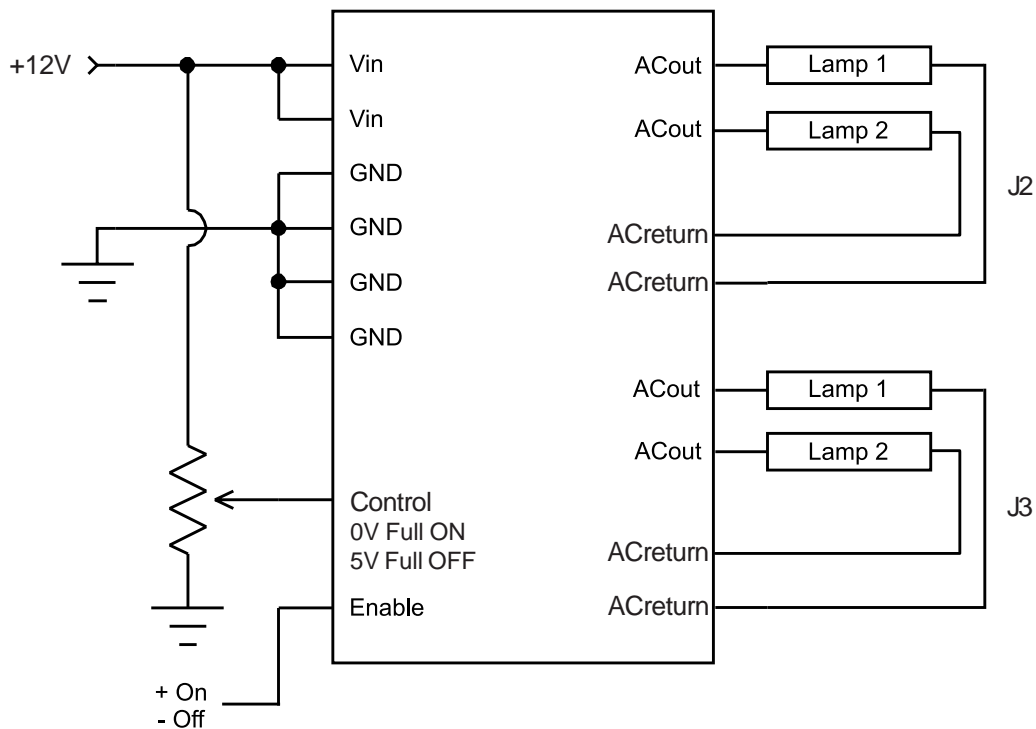

Figure 1



Endicott Research Group, Inc. (ERG) reserves the right to make changes in circuit design and/or specifications at any time without notice. Accordingly, the reader is cautioned to verify that data sheets are current before placing orders. Information furnished by ERG is believed to be accurate and reliable. However, no responsibility is assumed by ERG for its use.