Features

- Operates from Single Supply: 3.3V
- Small Footprint 64-Pin TQFP Package or Flip Chip
- Precision Low-voltage Monitor Circuitry for the Power Supply
- Master Power on Reset
- Serial Port Interface with Read-back Capability
- Over-temperature Protection/Warning
- Shock Sensor Signal Processing
- On-chip 1.8V, 2.5V and -3V Regulators
- Low Power Consumption, 9 mA in Normal Run Mode
- Spindle Driver
 - Commutator is Driven by a FLL for High Immunity to Jitter
 - Programmable 10-bit DAC
 - Adjustable Slew Rate Control
 - External Startup Capability
 - 0.4A Current Capability with $R_{on} = 1.4\Omega$
 - Digital Commutation Delay and Blanking
 - Programmable Delay from BEMF Zero Crossing
 - External INDEX Signal for Spin Lock
 - Active Spindle Braking Capability
- VCM Driver
 - 0.4A Current Capability with $R_{on} = 2.2\Omega$
 - Programmable 14-bit DAC
 - Ramp Load/Unload Capability with 10-bit ADC
 - Programmable VCM Current Controlled by Sense Resistor
- Packaging: Variety Available Depending on Customer Needs

Description

The AT78C7015 is a CMOS monolithic device that integrates Spindle and VCM controllers as well as power stages into one chip. The device operates from 3.3V power supply. The AT78C7015 is designed for a small-form-factor hard disk drive application.

A precision low-voltage detection circuit monitors the power supply and initiates VCM retract at voltage fault condition. A 3-line serial port interface with read back capability provides interface to the microprocessor.

The Spindle driver features a transconductance amplifier, a current sense amplifier, power output drivers, sequencer, internal delay/masking logic, Spindle brake circuit, FLL, and charge-pump for locking the spindle to the programmed rotational speed.

The VCM driver features a transconductance amplifier, differential input current sense amplifier, ramp load/unload capability, and power output amplifier.



Spindle/VCM Motor Controller/ Drivers

AT78C7015

Summary

3439BS-NETST-5/04



Note: This is a summary document. A complete document is available under NDA. For more information, please contact your local Atmel sales office.

AT78C7015 Block Diagram

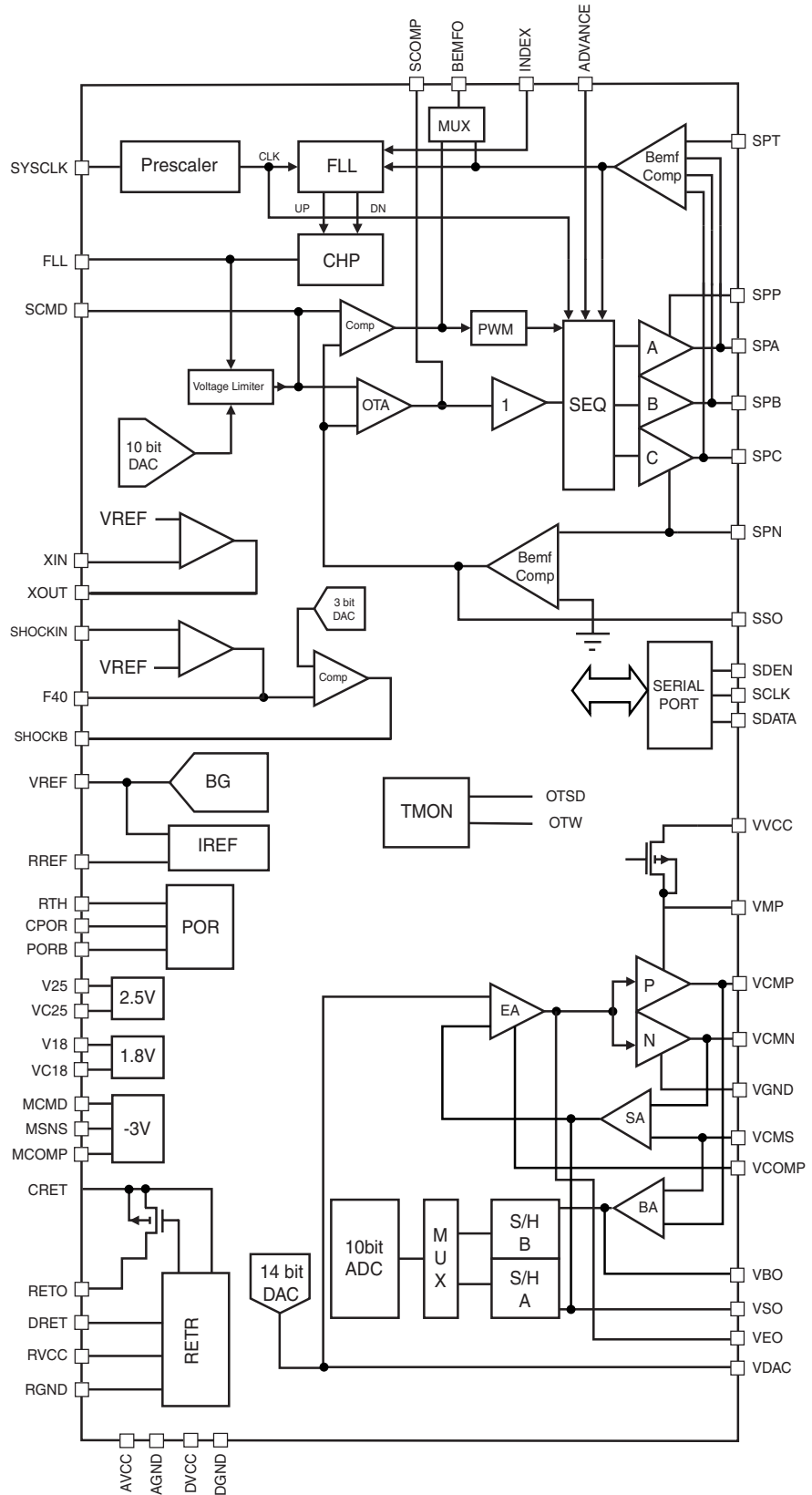

Ordering Information

Ordering Code	Package	Operation Range
AT78C7015	64A1	

Package Type	
64A1	64-lead, 10 x 10 mm Body Size, 1.0 mm Body Thickness, 0.5 mm Lead Pitch, Thin Profile Plastic Quad Flat Package (TQFP)

Packaging Information

64A1 – TQFP

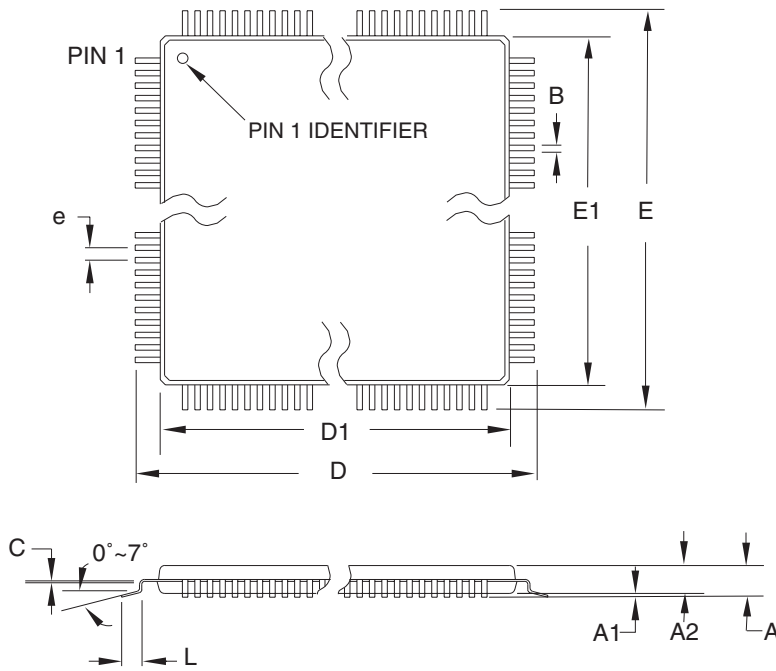

COMMON DIMENSIONS
(Unit of Measure = mm)

SYMBOL	MIN	NOM	MAX	NOTE
A	–	–	1.20	
A1	0.05	–	0.15	
A2	0.95	1.00	1.05	
D	11.75	12.00	12.25	
D1	9.90	10.00	10.10	Note 2
E	11.75	12.00	12.25	
E1	9.90	10.00	10.10	Note 2
B	0.30	–	0.45	
C	0.09	–	0.20	
L	0.45	–	0.75	
e	0.50 TYP			

- Notes:
1. This package conforms to JEDEC reference MS-026, Variation ACD.
 2. Dimensions D1 and E1 do not include mold protrusion. Allowable protrusion is 0.25 mm per side. Dimensions D1 and E1 are maximum plastic body size dimensions including mold mismatch.
 3. Lead coplanarity is 0.10 mm maximum.

4/22/2004

2325 Orchard Parkway San Jose, CA 95131	TITLE	DRAWING NO.	REV.
	64A1 , 64-lead, 10 x 10 mm Body Size, 1.0 mm Body Thickness, 0.5 mm Lead Pitch, Thin Profile Plastic Quad Flat Package (TQFP)	64A1	A



Atmel Corporation

2325 Orchard Parkway
San Jose, CA 95131, USA
Tel: 1(408) 441-0311
Fax: 1(408) 487-2600

Regional Headquarters

Europe

Atmel Sarl
Route des Arsenalux 41
Case Postale 80
CH-1705 Fribourg
Switzerland
Tel: (41) 26-426-5555
Fax: (41) 26-426-5500

Asia

Room 1219
Chinachem Golden Plaza
77 Mody Road Tsimshatsui
East Kowloon
Hong Kong
Tel: (852) 2721-9778
Fax: (852) 2722-1369

Japan

9F, Tonetsu Shinkawa Bldg.
1-24-8 Shinkawa
Chuo-ku, Tokyo 104-0033
Japan
Tel: (81) 3-3523-3551
Fax: (81) 3-3523-7581

Atmel Operations

Memory

2325 Orchard Parkway
San Jose, CA 95131, USA
Tel: 1(408) 441-0311
Fax: 1(408) 436-4314

Microcontrollers

2325 Orchard Parkway
San Jose, CA 95131, USA
Tel: 1(408) 441-0311
Fax: 1(408) 436-4314

La Chantrerie
BP 70602
44306 Nantes Cedex 3, France
Tel: (33) 2-40-18-18-18
Fax: (33) 2-40-18-19-60

ASIC/ASSP/Smart Cards

Zone Industrielle
13106 Rousset Cedex, France
Tel: (33) 4-42-53-60-00
Fax: (33) 4-42-53-60-01

1150 East Cheyenne Mtn. Blvd.
Colorado Springs, CO 80906, USA
Tel: 1(719) 576-3300
Fax: 1(719) 540-1759

Scottish Enterprise Technology Park
Maxwell Building
East Kilbride G75 0QR, Scotland
Tel: (44) 1355-803-000
Fax: (44) 1355-242-743

RF/Automotive

Theresienstrasse 2
Postfach 3535
74025 Heilbronn, Germany
Tel: (49) 71-31-67-0
Fax: (49) 71-31-67-2340

1150 East Cheyenne Mtn. Blvd.
Colorado Springs, CO 80906, USA
Tel: 1(719) 576-3300
Fax: 1(719) 540-1759

Biometrics/Imaging/Hi-Rel MPU/ High Speed Converters/RF Datacom

Avenue de Rochepleine
BP 123
38521 Saint-Egreve Cedex, France
Tel: (33) 4-76-58-30-00
Fax: (33) 4-76-58-34-80

Literature Requests

www.atmel.com/literature

Disclaimer: Atmel Corporation makes no warranty for the use of its products, other than those expressly contained in the Company's standard warranty which is detailed in Atmel's Terms and Conditions located on the Company's web site. The Company assumes no responsibility for any errors which may appear in this document, reserves the right to change devices or specifications detailed herein at any time without notice, and does not make any commitment to update the information contained herein. No licenses to patents or other intellectual property of Atmel are granted by the Company in connection with the sale of Atmel products, expressly or by implication. Atmel's products are not authorized for use as critical components in life support devices or systems.

© Atmel Corporation 2004. All rights reserved. Atmel® and combinations thereof, are the registered trademarks of Atmel Corporation or its subsidiaries. Other terms and product names may be the trademarks of others.



Printed on recycled paper.

3439BS-NETST-5/04