



Super I/O with LPC Interface with FIR and Consumer IR Support

PRODUCT FEATURES

Data Brief

- 3.3 Volt Operation (5V tolerant)
- GPIOs (1)
- XNOR Chain
- PC99a, PC2001
- 36-pin QFN Lead-free RoHS Compliant Package
- Intelligent Auto Power Management
- Infrared Communications Controllers
 - One IR Port
 - Multi-Protocol Serial Communications Controllers
 - IrDA v1.2 (4Mbps), HPSIR, ASKIR, Consumer IR Support
 - Multiple Base I/O Address options, 15 IRQ Options and 3 DMA Options
 - Two Pin Serial Port (UART) Support
- Multi-Mode Parallel Port with ChiProtect™
 - Standard Mode IBM PC/XT®, PC/AT®, and PS/2™ Compatible Bidirectional Parallel Port
 - Enhanced Parallel Port (EPP) Compatible - EPP 1.7 and EPP 1.9 (IEEE 1284 Compliant)
 - IEEE 1284 Compliant Enhanced Capabilities Port (ECP)
 - ChiProtect Circuitry for Protection Against Damage Due to Printer Power-On
 - 192 Base I/O Address, 15 IRQ and 3 DMA Options
- LPC Bus Host Interface
 - Multiplexed Command, Address and Data Bus
 - 8-Bit I/O Transfers
 - 8-Bit DMA Transfers
 - 16-Bit Address Qualification
 - Serial IRQ Interface Compatible with Serialized IRQ Support for PCI Systems
 - PCI CLKRUN# Support

ORDER NUMBER: SIO1036-ZG FOR 36 PIN, QFN LEAD-FREE ROHS COMPLIANT PACKAGE



80 ARKAY DRIVE, HAUPPAUGE, NY 11788 (631) 435-6000, FAX (631) 273-3123

Copyright © 2007 SMSC or its subsidiaries. All rights reserved.

Circuit diagrams and other information relating to SMSC products are included as a means of illustrating typical applications. Consequently, complete information sufficient for construction purposes is not necessarily given. Although the information has been checked and is believed to be accurate, no responsibility is assumed for inaccuracies. SMSC reserves the right to make changes to specifications and product descriptions at any time without notice. Contact your local SMSC sales office to obtain the latest specifications before placing your product order. The provision of this information does not convey to the purchaser of the described semiconductor devices any licenses under any patent rights or other intellectual property rights of SMSC or others. All sales are expressly conditional on your agreement to the terms and conditions of the most recently dated version of SMSC's standard Terms of Sale Agreement dated before the date of your order (the "Terms of Sale Agreement"). The product may contain design defects or errors known as anomalies which may cause the product's functions to deviate from published specifications. Anomaly sheets are available upon request. SMSC products are not designed, intended, authorized or warranted for use in any life support or other application where product failure could cause or contribute to personal injury or severe property damage. Any and all such uses without prior written approval of an Officer of SMSC and further testing and/or modification will be fully at the risk of the customer. Copies of this document or other SMSC literature, as well as the Terms of Sale Agreement, may be obtained by visiting SMSC's website at <http://www.smcs.com>. SMSC is a registered trademark of Standard Microsystems Corporation ("SMSC"). Product names and company names are the trademarks of their respective holders.

SMSC DISCLAIMS AND EXCLUDES ANY AND ALL WARRANTIES, INCLUDING WITHOUT LIMITATION ANY AND ALL IMPLIED WARRANTIES OF MERCHANTABILITY, FITNESS FOR A PARTICULAR PURPOSE, TITLE, AND AGAINST INFRINGEMENT AND THE LIKE, AND ANY AND ALL WARRANTIES ARISING FROM ANY COURSE OF DEALING OR USAGE OF TRADE. IN NO EVENT SHALL SMSC BE LIABLE FOR ANY DIRECT, INCIDENTAL, INDIRECT, SPECIAL, PUNITIVE, OR CONSEQUENTIAL DAMAGES; OR FOR LOST DATA, PROFITS, SAVINGS OR REVENUES OF ANY KIND; REGARDLESS OF THE FORM OF ACTION, WHETHER BASED ON CONTRACT; TORT; NEGLIGENCE OF SMSC OR OTHERS; STRICT LIABILITY; BREACH OF WARRANTY; OR OTHERWISE; WHETHER OR NOT ANY REMEDY OF BUYER IS HELD TO HAVE FAILED OF ITS ESSENTIAL PURPOSE, AND WHETHER OR NOT SMSC HAS BEEN ADVISED OF THE POSSIBILITY OF SUCH DAMAGES.

General Description

The SMSC SIO1036 is a 3.3V PC 99, PC2001 compliant Super I/O Controller. The SIO1036 implements the LPC interface, a pin reduced ISA interface which provides the same or better performance as the ISA/X-bus with a substantial savings in pins used. The part also includes 1 GPIO pin.

The SIO1036 incorporates a Multi-Mode parallel port with ChiProtect™ circuitry plus EPP and ECP support. The parallel port is compatible with IBM PC/AT architectures, as well as IEEE 1284 EPP and ECP. The parallel port ChiProtect™ circuitry prevents damage caused by an attached powered printer when the SIO1036 is not powered.

The SIO1036 offers a full 16-bit internally decoded address bus, a Serial IRQ interface with PCI CLKRUN# support, relocatable configuration ports, and three DMA channel options.

There is a dedicated Serial Infrared interface UART, which complies with IrDA v1.2 (Fast IR), HPSIR, and ASKIR formats (used by Sharp and other PDAs), as well as Consumer IR. This can also be used as a 2 pin UART.

The SIO1036 features Software Configurable Logic (SCL) for ease of use. SCL allows programmable system configuration of key functions such as the parallel port and UART.

The SIO1036 supports the ISA Plug-and-Play Standard register set (Version 1.0a) and provides the recommended functionality to support Windows operating systems, PC99, and PC2001. The I/O Address, DMA Channel, and Hardware IRQ of each device in the SIO1036 may be reprogrammed through the internal configuration registers. There are multiple I/O address location options, a Serialized IRQ interface, and three DMA channels.

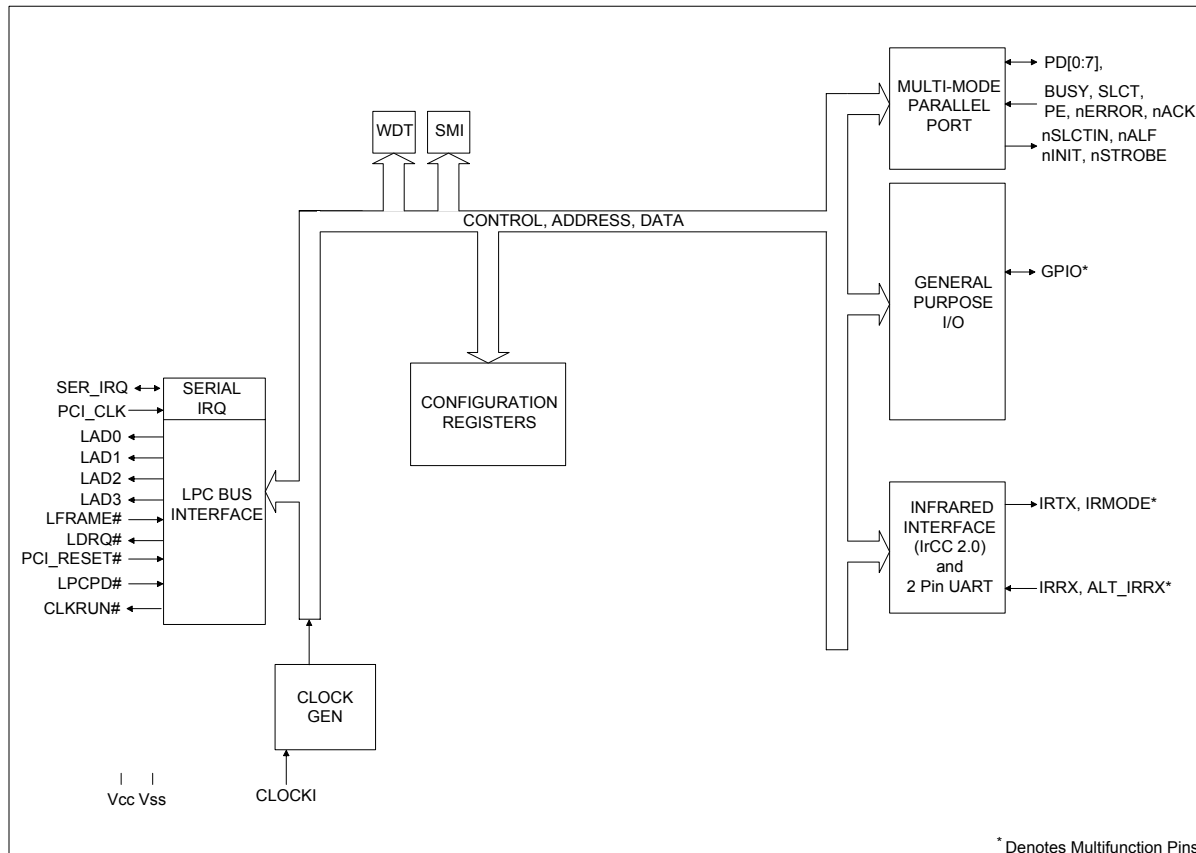

Figure 1 SIO1036 Block Diagram

Package Outline

REVISION HISTORY				
REVISION	DESCRIPTION	DATE	RELEASED BY	
-	SEE SPEC FRONT PAGE FOR REVISION HISTORY	-	-	

COMMON DIMENSIONS					
SYMBOL	MIN	NOM	MAX	NOTE	REMARK
A	0.80	-	1.00	-	OVERALL PKG HEIGHT
A1	0	0.02	0.05	-	STANDOFF
A2	0.60	-	0.80	-	MOLD THICKNESS
A3	-	0.20 REF	-	-	LEAD FRAME THICKNESS
D/E	5.85	6.00	6.15	-	"X"/"Y" BODY SIZE
D1/E1	5.55	-	5.95	-	"X"/"Y" MOLD SIZE
D2/E2	SEE VARIATIONS			-	"X"/"Y" EXPOSED PAD SIZE
L	0.35	-	0.75	-	TERMINAL LENGTH
b	0.18	0.25	0.30	2	TERMINAL WIDTH
e	-	0.50 BSC	-	-	TERMINAL PITCH
ccc	-	-	0.08	4	COPLANARITY

D2 / E2 VARIATIONS				
MIN	NOM	MAX	NOTE	CATALOG PART
3.55	3.70	3.85	-	USB3280, USB2502
				EMC6W201
				SIO1036

3-D VIEWS

NOTES:

- ALL DIMENSIONS ARE IN MILLIMETER.
- POSITION TOLERANCE OF EACH TERMINAL IS $\pm 0.05\text{mm}$ AT MAXIMUM MATERIAL CONDITION. DIMENSIONS "b" APPLIES TO PLATED TERMINALS AND IT IS MEASURED BETWEEN 0.15 AND 0.30 mm FROM THE TERMINAL TIP.
- DETAILS OF TERMINAL #1 IDENTIFIER ARE OPTIONAL BUT MUST BE LOCATED WITHIN THE AREA INDICATED.
- COPLANARITY ZONE APPLIES TO EXPOSED PAD AND TERMINALS.

UNLESS OTHERWISE SPECIFIED, DIMENSIONS ARE IN MILLIMETERS AND TOLERANCES ARE: DECIMAL: ±0.1 X.XX: ±0.05 X.XXX: ±0.025 DIM AND TOL PER ASME Y14.5M-1994		THIRD ANGLE PROJECTION			80 ARROYO CIRCLE HAUPPAUGE, NY 11768 USA	
MATERIAL: -	DATE: 12/6/04	NAME: S.K.I.LIEV	DATE: 12/6/04	PACKAGE OUTLINE 36 TERMINAL QFN, 6x6mm BODY, 0.5mm PITCH		
FINISH: -	DATE: 12/6/04	DESIGNED: S.K.I.LIEV	DATE: 12/6/04			
APPROVED: S.K.I.LIEV	DATE: 12/6/04	SCALE: 1:1	STD COMPLIANCE: JEDEC: MO-220	SHEET: 1 OF 1		