

Fiber Optic Transmitter

OPF672 , OPF673 Series



Features:

- Low cost 850 nm LED technology
- High thermal stability
- High optical coupling efficiency to multimode fiber
- Standard and low profile metal ST* style receptacles
- Industrial temperature range

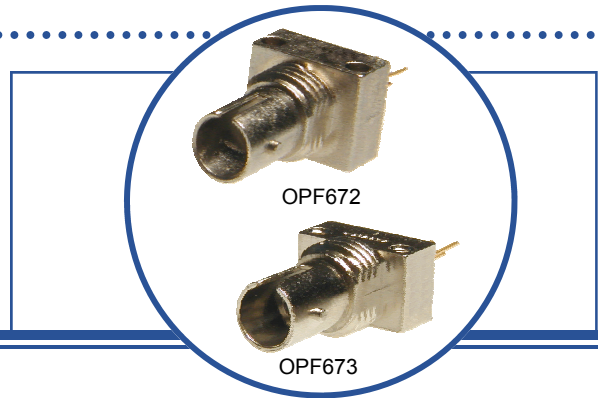

Description:

The **OPF672** and **OPF673** series fiber optic transmitters are high performance devices packaged for data communication links. These transmitters are an 850 nm GaAlAs LED and are specifically designed to efficiently launch optical power into either 50/125µm or 62.5/125µm diameter multimode fiber. Three power ranges with upper and lower limits are offered, which allows the designer to select a device best suited for the application.

The **OPF672** is offered a standard profile, metal ST receptacle and the **OPF673** is offered in a low profile version. These products combination of features including high speed and efficient coupled power makes it an ideal transmitter for integration into all types of data communications equipment.

Applications:

- Industrial Ethernet equipment
- Copper-to-fiber media conversion
- Intra-system fiber optic links
- Video surveillance systems

Ordering Information			
Part Number	LED Peak Wavelength	P _{T50} (dBm) Min / Max	T _r , T _f (ns) Typ / Max
OPF672-1; OPF673-1	850nm	-17.5/-15.2	8.0/10.0
OPF672-2; OPF673-2	850nm	-16.0/-13.0	8.0/10.0
OPF672-3; OPF673-3	850nm	-14.5/-11.5	8.0/10.0



RoHS

OPTEK reserves the right to make changes at any time in order to improve design and to supply the best product possible.

Absolute Maximum Ratings

$T_A = 25^\circ\text{C}$ unless otherwise noted

Storage Temperature Range	-55° C to +100° C
Operating Temperature Range	-40° C to +85° C
Lead Soldering Temperature ⁽¹⁾	260° C
Continuous Forward Current ⁽²⁾	100 mA
Maximum Reverse Voltage	1.0 V

Electrical/Optical Characteristics ($T_A = 25^\circ\text{C}$ unless otherwise noted)

SYMBOL	PARAMETER	MIN	TYP	MAX	UNITS	CONDITIONS
P_{T50}	Total Coupled Power, OPF672-1, OPF673-1	-17.5		-15.2	dBm	$I_F = 100\text{ mA}$
	50/125 μm Fiber, OPF672-2, OPF673-2	-16.0		-13.0	dBm	
	NA = 0.20 OPF672-3, OPF673-3	-14.5		-11.5	dBm	
V_F	Forward Voltage	1.5		2.1	V	$I_F = 100\text{ mA}$
V_R	Reverse Voltage	1.8			V	$I_R = 100\ \mu\text{A}$
λ	Wavelength	830	850	870	nm	$I_F = 50\text{ mA}$
$\Delta\lambda$	Optical Bandwidth		35		nm	$I_F = 50\text{ mA}$
t_r, t_f	Rise and Fall Time		8.0	10.0	ns	$I_F = 100\text{ mA}$; 10% to 90% ⁽³⁾

Notes:

- Maximum of 5 seconds with soldering iron. Duration can be extended to 10 seconds when flow soldering. RMA flux is recommended.
- De-rate linearly at 1.0mA /°C above 25°C .
- No Pre-bias.
- All Optek fiber optic LED products are subjected to 100% burn-in as part of its quality control process. The burn-in conditions are 96 hours at 100mA drive current and 25°C ambient temperature.

Relative Coupled Power vs Forward Current

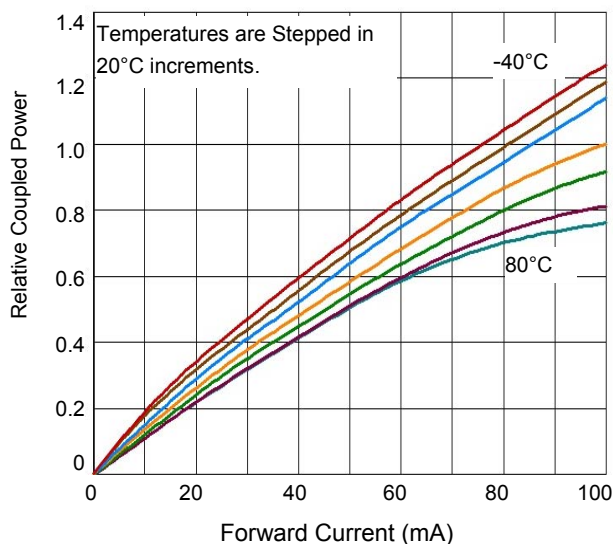

Typical Forward Voltage vs Forward Current

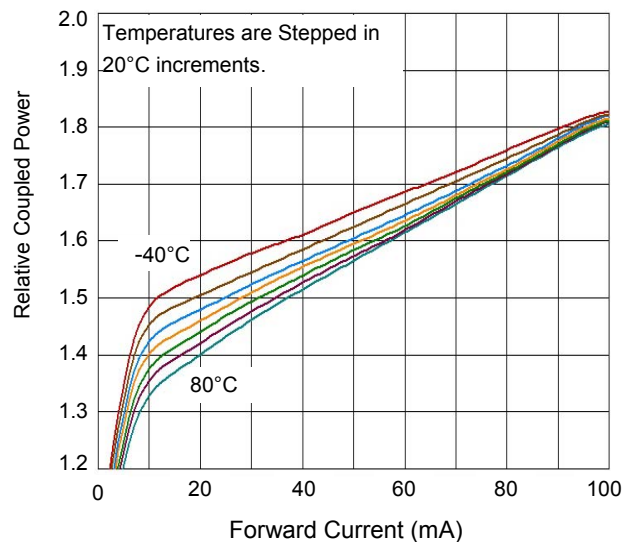

OPTEK reserves the right to make changes at any time in order to improve design and to supply the best product possible.

Mechanical Outline

OPF672-x

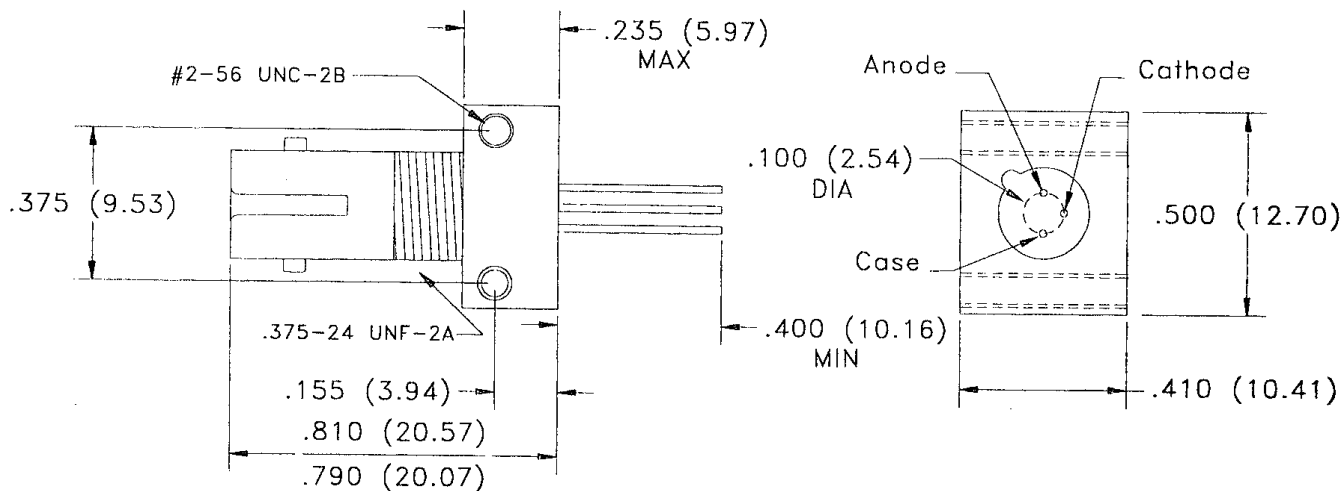

DIMENSIONS ARE IN INCHES (MILLIMETERS)

OPF673-x

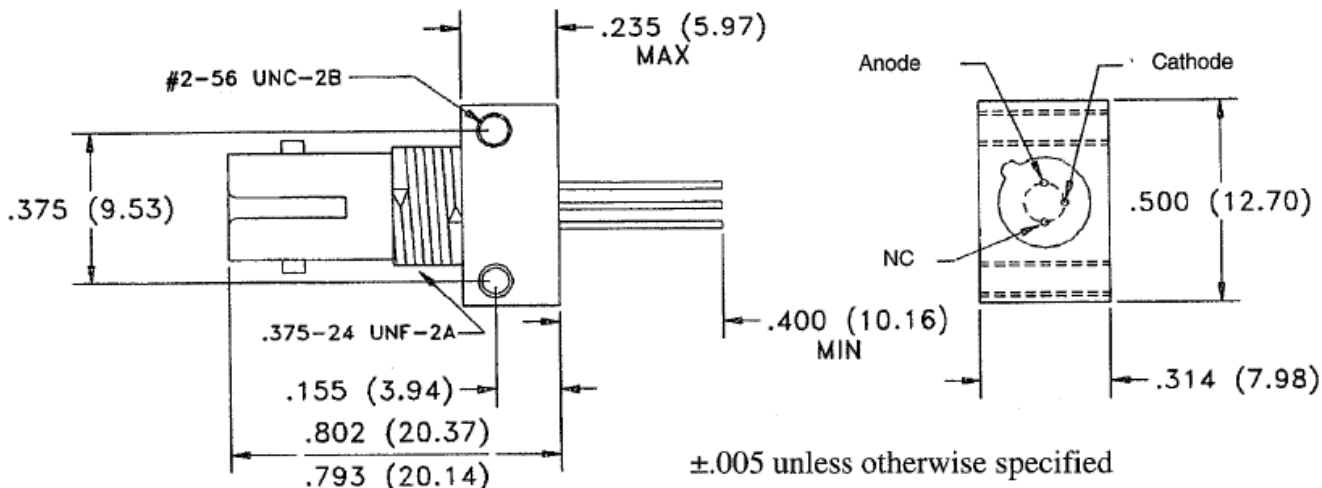

OPTEK reserves the right to make changes at any time in order to improve design and to supply the best product possible.