

Technical Data Sheet

Photolink- Fiber Optic Transmitter

PLT133/T5H

Features

- High speed signal transmission (16Mbps NRZ Signal)
- TTL interface compatible
- +3~+5V single power source
- Pb Free
- The product itself will remain within RoHS compliant version.

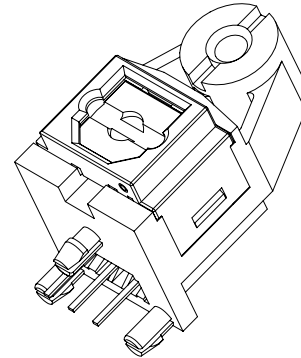

Descriptions

The opto-electrical component is assembled with a 660nm AlGaInP LED and a driver IC. It transforms the electrical signal to optical signal and be transmitted by 1mm diameter plastic optical fiber.

The component is operated at +3~+5V and has good performance at low dissipation current, steady light output and efficient light coupling.

Applications

- Digital audio equipment
- CD player
- DVD player

Device Selection Guide

Chip		Operating Voltage (Vcc)	Dissipation Current (mA)		Fiber Coupling Light Output (dBm)		
Material	λ p(nm)		Typ.	Max.	Min.	Typ.	Max.
AlGaInP	660	+3.0~5.0	5.5	10	-21	--	-15

Absolute Maximum Ratings(Ta = 25°C)

Parameter	Symbol	Rating	Unit
Supply Voltage	Vcc	-0.5 to 7	V
DC Input Voltage	Vin	-0.5 to Vcc+0.5	V
Storage Temperature	Tstg	-40 to 85	°C
Operating Temperature	Topr	-20 to 70	°C
Soldering Temperature	Tsol	260*	°C

* Soldering time ≤ 10 s.

Electro-Optical Characteristics

Parameter	Symbol	Conditions	MIN.	TYP.	MAX.	Unit
Operating Voltage	Vcc	Low Voltage	2.75	3.00	3.25	V
		High Voltage	4.75	5.00	5.25	V
Peak Emission Wavelength	λ_p		640	660	680	nm
Transmission Rate		NRZ Code	DC	-	16	Mbps
Fiber Coupling Output Power	Pf	*1	-21	-18	-15	dBm
Dissipation Current	Icc	*1	3	-	10	mA
High Level Input Voltage	V _{IH}		2	-	-	V
Low Level Input Voltage	V _{IL}		-	-	0.8	V
Low to High Delay Time	t _{pLH}	*2	-	-	120	ns
High to Low Delay Time	t _{pHL}	*2	-	-	120	ns
Pulse Width Distortion	Δtw	*2	-25	-	25	ns
Jitter	Δt_j	*2	-	-	20	ns

*All Plastic Optical Fiber (980/1000um)

*Circuit Layout Notice:

When power is off, it must be cut off together in Vin and Vcc pin. If it only has Vcc power-off, LED will be sparkling because LED is just threshold condition.

Measuring Method

*1 Measuring method of optical output coupling fiber and dissipation current

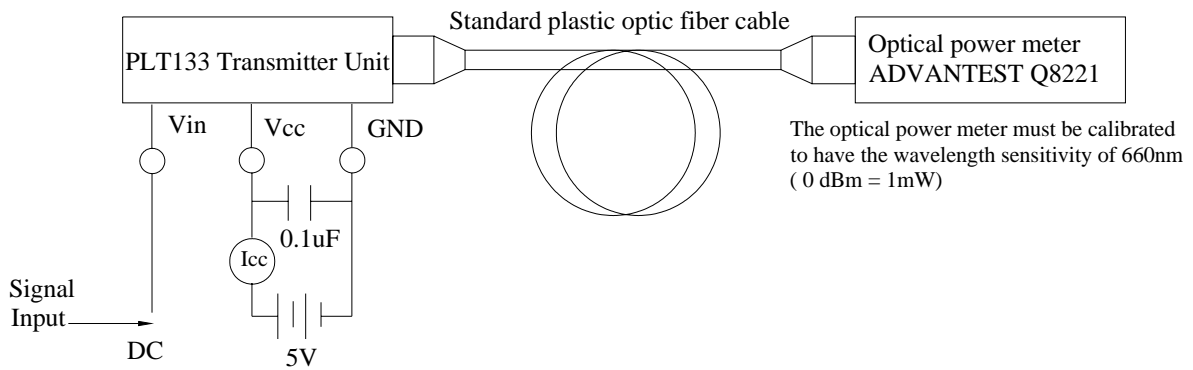

*2 Pulse response measuring method

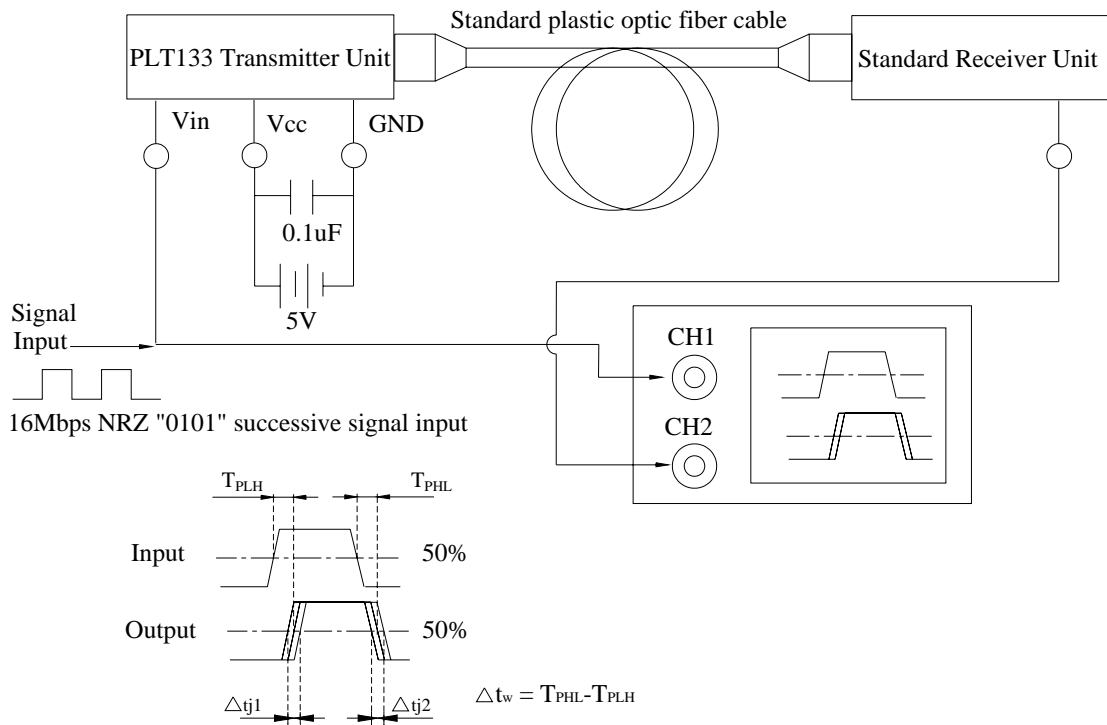

RELIABILITY TEST ITEMS

No.	Item	Test Condition	Test Hour/Cycle	Sample Size (Piece)	Number (n) Failure (c)
1	Soldering Heat	260°C±5°C	10 seconds	22	n=22, c=0
2	High Temp. Storage	Ta=100°C	1000hrs	22	n=22, c=0
3	Low Temp. Storage	Ta=-55°C	1000hrs	22	n=22, c=0
4	High Temp. & Humid. Test	Ta=85°C, RH=85%	1000hrs	22	n=22, c=0
5	Temperature Cycle	-40°C ~~~~ 85°C (30min) (5min) (30min)	300cycle	76	n=22, c=0
6	Thermal Shock	-10°C ~~~~ 100°C (5min) (10sec) (5min)	300cycle	76	n=22, c=0
7	DC Operating Life	Vcc=5V, Ta=25°C Vin: DC (5V)	1000hrs	76	n=22, c=0

*Icc(mA): Brightness Attenuate Difference < 20%

*Pf (Fiber Coupling Output Power) : Brightness Attenuate Difference < 20%

Packing Quantity Specification

- 1. Tube : 49 pcs/tube
- 2. Inner box : 20 tube/innerbox (980 pcs)
- 3. Outer box : 6 inner/outer (5880 pcs)

Label Form Specification



CPN: Customer's Production Number
P/N: Production Number
QTY: Packing Quantity
CAT: De-flash
HUE: IC
REF: Reference
LOT No: Lot Number
MADE IN TAIWAN: Production Place

Package Form

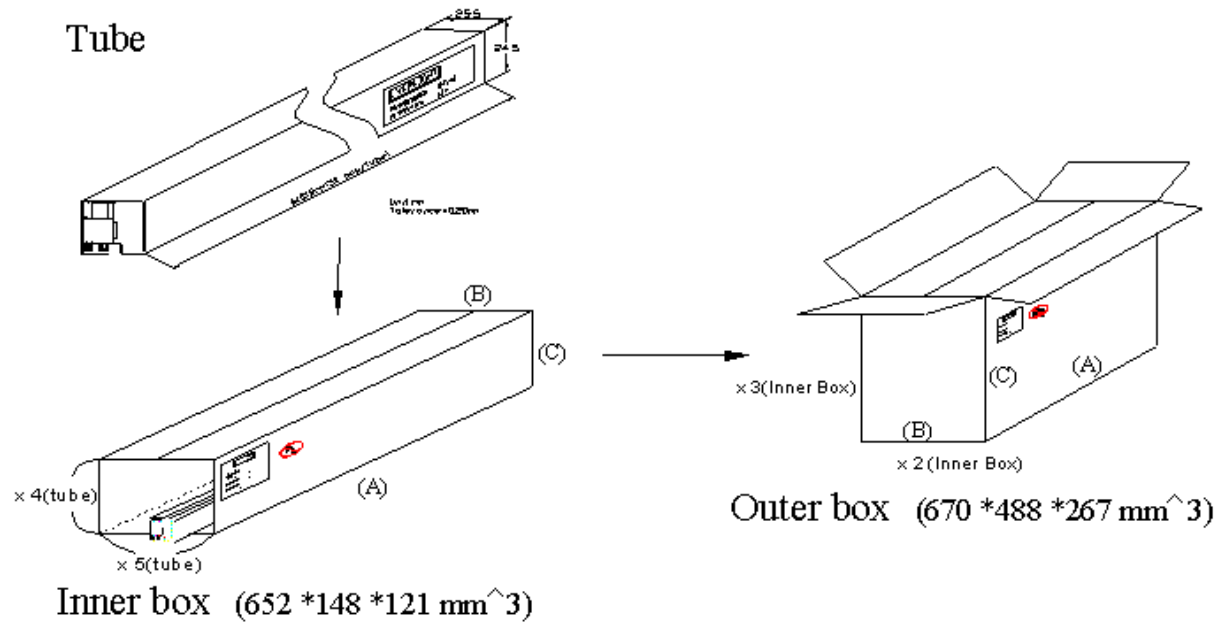

Notes

1. The both sides of tube must be sealed by using transparent adhesive.
2. Above specification may be changed without notice. EVERLIGHT will reserve authority on material change for above specification.
3. When using this product, please observe the absolute maximum ratings and the instructions for using outlined in these specification sheets. EVERLIGHT assumes no responsibility for any damage resulting from use of the product that does not comply with the absolute maximum ratings and the instructions included in these specification sheets.
4. These specification sheets include materials protected under copyright of EVERLIGHT Corporation. Please don't reproduce or cause anyone to reproduce them without EVERLIGHT's consent.

EVERLIGHT ELECTRONICS CO., LTD.*Office: No 25, Lane 76, Sec 3, Chung Yang Rd,
Tucheng, Taipei 236, Taiwan, R.O.C**Tel: 886-2-2267-2000, 2267-9936**Fax: 886-2267-6244, 2267-6189, 2267-6306**<http://www.everlight.com>*