

Fiber Optic GaAlAs High Speed LED in SMA Receptacle Types OPF391A, OPF391B, OPF391C, OPF391D

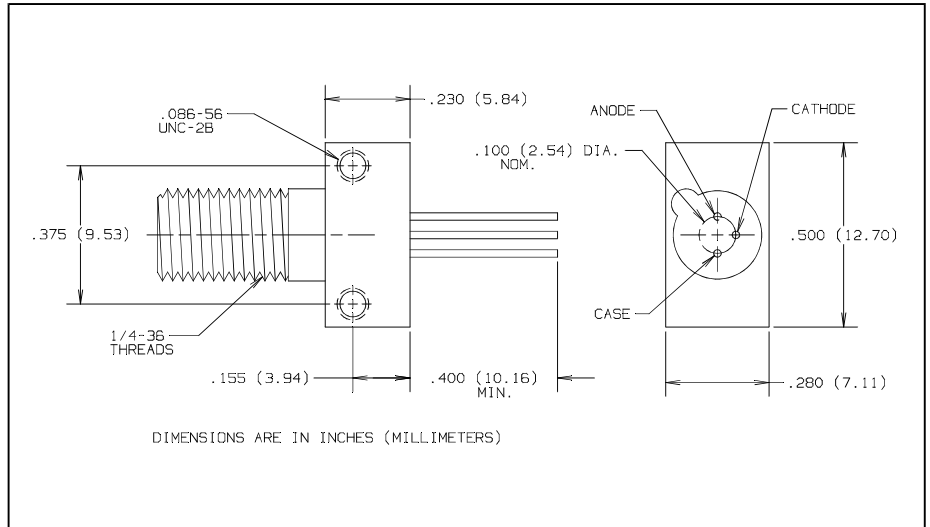
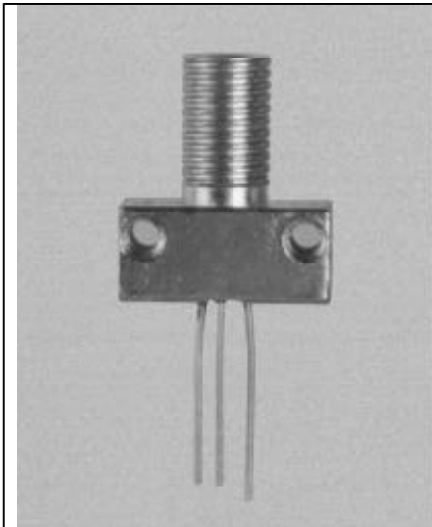

Features

- Component pre-mounted and ready to use
- Pre-tested with fiber to assure performance
- Popular SMA style receptacle
- High Speed
- Electrically isolated from case

Description

The OPF391 series LED consists of a low cost plastic cap LED, pre-mounted and aligned in an SMA receptacle. This configuration is designed for PC board or panel mounting. Includes lock washer and jam nut, two 2-56 screws, and a dust cap.

The LED's are designed to interface with multimode optical fibers from 50/125 to 200/300 microns.

Absolute Maximum Ratings ($T_A = 25^\circ\text{C}$ unless otherwise noted)

Reverse Voltage	1.0 V
Continuous Forward Current	100 mA ⁽⁴⁾
Storage Temperature Range	-55° C to +100° C
Operating Temperature Range	-40° C to +85° C
Lead Soldering Temperature [1/16 inch (1.6 mm) from case for 5 sec. with soldering iron]	240° C ⁽¹⁾

Notes:

- (1) RMA flux is recommended. Duration can be extended to 10 sec. max when flow soldering.
- (2) Graded index fiber, 50 μm core N.A. = 0.20.
- (3) To convert radiant power output to dBm, use the following expression $\text{dBm} = 10 \log (\mu\text{W}/1000)$.
- (4) Derate linearly @ 1.0 mA/ $^\circ\text{C}$ above 25° C.
- (5) Prebias @ 5 mA current.

LED Burn-in

All LED's are subject to 100% burn-in testing. Test conditions are 96 hours at 100 mA continuous current in 25° C ambient.

TYPICAL COUPLED POWER into OPTICAL FIBER

Typical Coupled Power $I_F = 100 \text{ mA} @ 25^\circ\text{C}$						
Fiber	Refractive Index	N.A.	OPF391D	OPF391C	OPF391B	OPF391A
50/125 μm	Graded	0.20	7.5 μW	12.5 μW	18 μW	25 μW
62.5/125 μm	Graded	0.28	27 μW	35 μW	45 μW	75 μW
100/140 μm	Graded	0.29	58 μW	85 μW	115 μW	170 μW
200/300 μm^*	Step	0.41	290 μW	450 μW	545 μW	650 μW

*PCS - Plastic Clad Silica

Types OPF391A, OPF391B, OPF391C, OPF391D

Electrical Characteristics ($T_A = 25^\circ\text{C}$ unless otherwise noted)

SYMBOL	PARAMETER	MIN	TYP	MAX	UNITS	TEST CONDITIONS
P_O	Radiant Power Output	OPF391D	5.0	7.5		μW $I_F = 100\text{ mA}^{(2)}$
		OPF391C	10.0	12.5		
		OPF391B	15.0	18.0		
		OPF391A	20.0	25.0		
V_F	Forward Voltage		1.8	2.0	V	$I_F = 100\text{ mA}$
λ_p	Peak Output Wavelength	830	850	870	nm	$I_F = 50\text{ mA}$
B	Spectral Bandwidth Between Half Power Points		35		nm	$I_F = 50\text{ mA}$
t_r	Output Rise Time		4.5	6.0	ns	$I_F = 100\text{ mA}$, 10%-90% ⁽⁵⁾
t_f	Output Fall Time		4.5	6.0	ns	$I_F = 100\text{ mA}$, 90%-10% ⁽⁵⁾

Typical Performance Curves

