

Multiprotocol XFP Optical Transceiver—1310 nm for up to 10 km Reach

JXP Series



Key Features

- Compliant with SONET OC-192 SR-1, 10 G Ethernet and 10 G Fibre Channel 10GBASE-LR, and corresponding Forward Error Correction (FEC) rates from 9.95 Gbps to 11.35 Gbps
- 1310 nm optical signals for up to 10 km reach
- RoHS 6/6 compliant
- Industrial operating case temperature range from -40°C to 85°C
- Low power consumption (< 2.5 W max)
- Excellent EMI performance
- Digital diagnostic monitoring support
- XFI system loopback implemented

Applications

- Wide area network (WAN)
- Local area network (LAN)
- Storage area network (SAN)
- SONET OC-192 applications
- SDH STM-64 applications
- Ethernet switches and applications
- Fibre Channel switches and applications

Compliance

- Telcordia GR-253-CORE standard
- ITU-T G.691 standard
- IEEE 802.3-2005 Clause 52 standard
- 10GFC 1200-SM-LL-L standard
- Class 1 Laser Safety
- Tested in accordance with Telcordia GR-468

The JDSU 10 Gbps 1310 nm multiprotocol XFP optical transceiver is a fully duplexed, integrated fiber optic transceiver that provides a high-speed serial link at signaling rates from 9.95 to 11.35 Gbps. The module complies with the 10 Gigabit Small Form Factor Pluggable (XFP) multisource agreement (MSA).

The 1310 nm XFP also complies with Telcordia GR-253-CORE (SONET) OC-192 SR-1 and ITU-T G.691 (SDH) STM-64 I-64.1 for 2 km reach, and IEEE 802.3-2005 Clause 52 (Ethernet) 10GBASE-LR and 10GFC (Fibre Channel) 1200-SM-LL-L for 10 km reach.

The 10 Gbps multiprotocol XFP optical transceiver integrates the receive and transmit path on one module. On the transmit side, the 10 Gbps serial data stream is recovered, retimed, and passed to a laser driver. The laser driver modulates a 1310 nm semicooled external modulated laser (EML), enabling data transmission over single-mode fiber through an industry standard LC connector. On the receive side, the 10 Gbps optical data stream is recovered from a PIN photodetector/transimpedance amplifier, retimed, and passed to an output driver. This module features a hot-pluggable, XFI-compliant electrical interface.

Section 1 Functional Description

The 10 Gbps 1310 nm multiprotocol XFP optical transceiver is a fully duplexed serial electric, serial optical device with both transmit and receive functions contained in a single module that provides a high-speed serial link at signaling rates from 9.95 to 11.35 Gbps. It is designed to be compliant with Telcordia GR-253-CORE OC-192 SR-1 for 2 km reach (SONET), ITU-T G.691 STM-64 I-64.1 for 2 km reach (SDH), IEEE 802.3-2005 Clause 52 10GBASE-LR and 10G BASE-LW for 10 km reach (Ethernet) and 10GFC 1200-SM-LL-L for 10 km reach (Fibre Channel). The transceiver is also fully compliant with the 10 Gigabit Small Form Factor XFP Pluggable Module MSA INF8077i Rev. 4.5. A block diagram of the 10 Gbps 1310 nm multiprotocol XFP optical transceiver is shown in Figure 1.

The 10 Gbps 1310 nm multiprotocol XFP optical transceiver locks to data without the requirement of reference clock. The reference clock inputs have an internal 100 Ω differential line-to-line termination. It has several low-speed interface connections, including a two-wire serial interface. These connections include module not ready (Mod_NR), module deselect (Mod_DeSel), Interrupt, transmitter disable (TX_DIS), module absent (Mod_ABS), receive loss (RX_LOS), and power down/reset (P_Down/RST).

The XFP transceiver also supports XFI loopback. In this mode, data input on the electrical Tx pins of the XFP module is retimed and is redirected to the Rx pins of the module. This facilitates system-side test and debug operations.

Transmitter

The transmitter path converts serial NRZ electrical data from line rate of 9.95 to 11.35 Gbps to a standard compliant optical signal. The transmitter accepts a 100 Ω differential 120 mV peak-to-peak to 820 mV peak-to-peak 10 Gbps CML electrical signal on TD- and TD+ pins.

Inside the module, the differential signals pass through a signal conditioner with equalization that compensates for losses and deterministic jitter present on the input data stream. The transmit CDR function generates a clock that is at the same frequency as the incoming data bit rate of the electrical data input. The clock is phase aligned by a phase locked loop (PLL) that samples the data in the center of the data eye pattern. The CDR function does not require a reference clock to “lock” to incoming data. The CDR contains a lock detect circuit that indicates successful locking of the PLL onto the incoming data.

The output of the Tx signal conditioner is input to the laser driver circuit, which transforms the small swing digital voltage to an output modulation that drives a semi-cooled, electroabsorption (EA) modulator. The optical signal is engineered to meet the SONET/SDH, 10 G Ethernet, 10 G Fibre Channel and corresponding forward error correction (FEC) rates specifications. Closed-loop control of the transmitted laser power and modulation swing over temperature and voltage variations is provided. The laser is coupled to single-mode optical fiber through an industry-standard LC optical connector.

Receiver

The receiver converts incoming DC balanced serial NRZ optical data from line rate of 9.95 to 11.35 Gbps into serial XFI electrical data. Light is coupled to a PIN photodetector from single-mode optical fiber through an industry-standard LC optical connector. The electrical current from the PIN photodetector is converted to a voltage in a high-gain transimpedance amplifier.

The amplified signal is passed to a signal conditioning IC that provides clock and data recovery. The receive CDR function generates a clock that is at the same frequency as the incoming data bit rate of the optical data input. The clock is phase aligned by a PLL that samples the data in the center of the data eye pattern. The CDR function does not require a reference clock to “lock” to incoming data. The CDR contains a lock detect circuit that indicates successful locking of the PLL onto the incoming data. Loss of signal, and signal lock detection is included in the receive circuitry that is reflected in the Mod_NR status pin. The recovered data is output on the RD+ and RD- pins as a 100 Ω 340 mV peak-to-peak CML signal. The output signal meets the XFP MSA requirements.

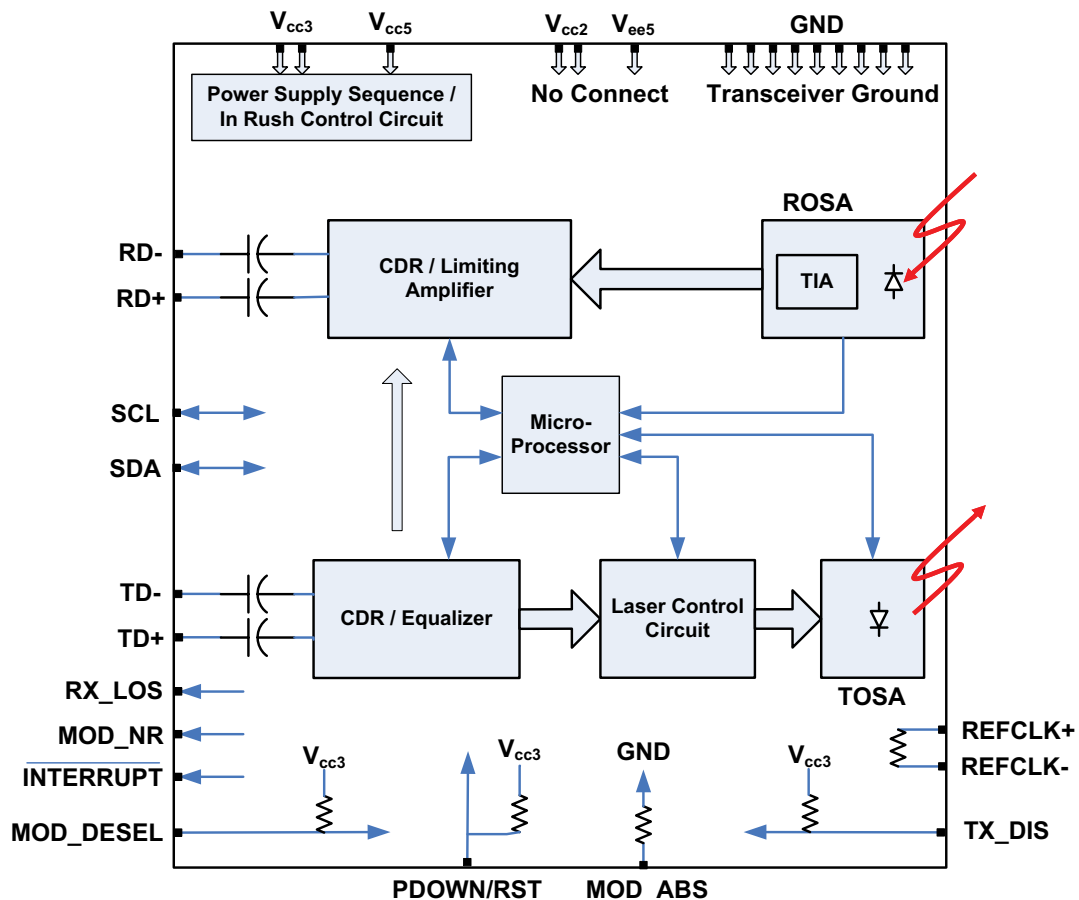

Figure 1 JDSU 10 Gbps 1310 nm multiprotocol XFP optical transceiver functional block diagram

Low-speed Signaling

Low-speed signaling is based on low voltage TTL (LVTTTL) operating at a nominal voltage of 3.3 V.

SCL/SDA: Two-wire serial interface clock and data line. Hosts should use a pull-up resistor connected to Vcc 3.3 V on the two-wire interface SCL (clock), SDA (data), and all low speed outputs.

Mod_NR: Output pin. When asserted high, indicates that the module has detected a condition that renders Tx and or Rx data invalid.

Mod_DeSel: Input pin. When held low by the host the module responds to two-wire serial communication commands. When high, the module does not respond to, or acknowledge any, two-wire interface communication from the host.

Interrupt: Output pin. When low, indicates possible module operational fault or a status critical to the host system.

TX_DIS: Input pin. When asserted high, the transmitter output is turned off.

Mod_ABS: Output pin. Asserted high when the XFP module is absent, and is pulled low when the XFP module is inserted.

RX_LOS: Output pin. Asserted high when insufficient optical power for reliable signal reception is received.

P_Down/RST: Multifunction input pin. The module can be powered down or reset by pulling the low-speed, P-Down pin high. In power-down mode, no data is transmitted on the optical Tx or the electrical Rx path. The reset pulse is generated on the falling edge of the P-Down signal. Following reset, the internal PLLs must reacquire lock and will temporarily indicate a Mod_NR failure until the PLLs reacquire lock.

Section 2 Application Schematics

Recommended MSA connections to the 10 Gbps 1310 nm multiprotocol XFP optical transceiver are shown in Figure 2.

Power supply filtering is recommended for the JDSU 10 Gbps 1310 nm multiprotocol XFP optical transceiver. To limit wide band noise power, the host system and module shall each meet a maximum of two percent peak-to-peak noise when measured with a one MHz low-pass filter. In addition, the host system and the module shall each meet a maximum of three percent peak-to-peak noise when measured with a filter from 1 – 10 MHz.

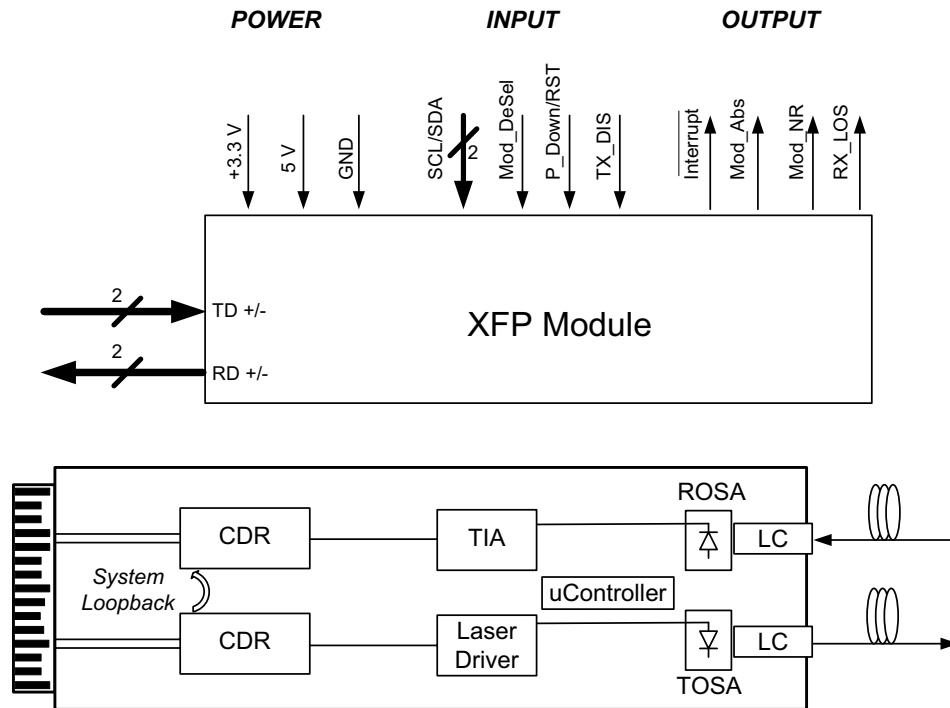

Figure 2 Application schematics for the 10 Gbps 1310 nm XFP optical transceiver

Section 3 Specifications

Technical specifications related to the 10 Gbps 1310 nm multiprotocol XFP optical transceiver includes:

- Section 3.1 Pin Function Definitions
- Section 3.2 XFP/XFI Reference Model Compliance Points
- Section 3.3 Absolute Maximum Ratings
- Section 3.4 Operating Conditions
- Section 3.5 Electrical Characteristics
- Section 3.6 Jitter Specifications
- Section 3.7 Timing Requirement of Control and Status I/O
- Section 3.8 XFP Two-wire Interface Protocol and Management Interface
- Section 3.9 Optical Transmitter Characteristics
- Section 3.10 Optical Receiver Characteristics
- Section 3.11 Regulatory Compliance
- Section 3.12 PCB Layout
- Section 3.13 Module Outline
- Section 3.14 Connectors

6

3.1 Pin Function Definitions

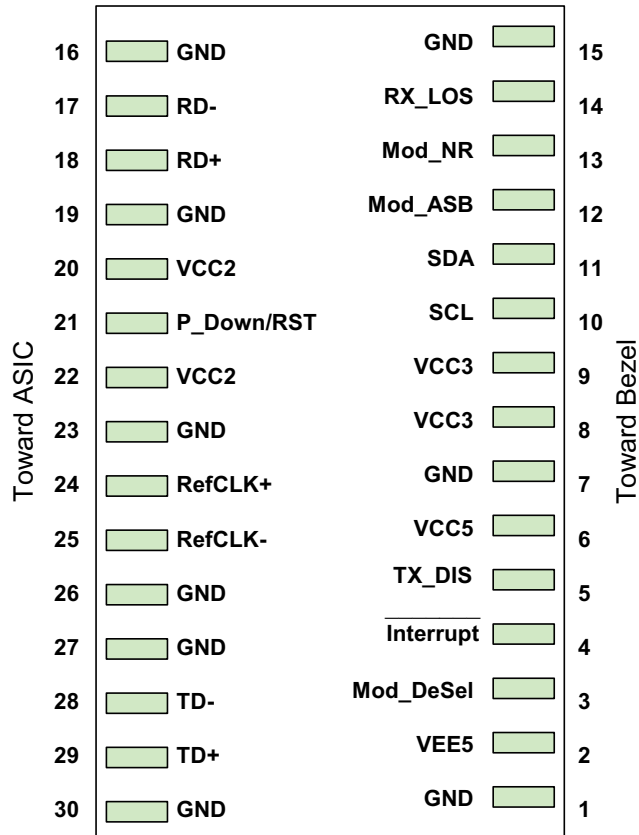

Figure 3 XFP optical transceiver pin-out on host board

7

Table 1 XFP Optical Transceiver Pin Descriptions

Pin Number	Type	Name	Description
1		GND ¹	Module Ground
2		VEE5	Not used; may be left unconnected (Optional -5.2 V Power Supply)
3	LVTTL-I	Mod_Desel	Module Deselect; When held low allows the module to respond to two-wire serial interface commands
4	LVTTL-O	Interrupt ²	Interrupt; Indicates presence of an important condition which can be read over the serial two-wire interface
5	LVTTL-I	TX_DIS	Transmitter Disable; Transmitter Laser Source Turned Off
6		VCC5	+5 V Power Supply
7		GND ¹	Module Ground
8		VCC3	+3.3 V Power Supply
9		VCC3	+3.3 V Power Supply
10	LVTTL-I	SCL ²	Two-wire Interface Clock
11	LVTTL-I/O	SDA ²	Two-wire Interface Data Line
12	LVTTL-O	Mod_Abs ²	Indicates Module is not present. Grounded in the Module
13	LVTTL-O	Mod_NR ²	Module Not Ready; Indicating Module Operational Fault
14	LVTTL-O	RX_LOS ²	Receiver Loss Of Signal Indicator
15		GND ¹	Module Ground
16		GND ¹	Module Ground
17	CML-O	RD-	Receiver Inverted Data Output
18	CML-O	RD+	Receiver Noninverted Data Output
19		GND ¹	Module Ground
20		VCC2	+1.8 V Power Supply (not used)
21	LVTTL-I	P_Down/RST	Power down; When high, the module limits power consumption to 1.5 W or below. Serial interface is functional in the low power mode. Reset; The falling edge initiates a complete reset of the module including the serial interface, equivalent to a power cycle.
22		VCC2	+1.8 V Power Supply (not used)
23		GND ¹	Module Ground
24	PECL-I	RefCLK+	Reference Clock Noninverted Input (not used)
25	PECL-I	RefCLK-	Reference Clock Inverted Input (not used)
26		GND ¹	Module Ground
27		GND ¹	Module Ground
28	CML-I	TD-	Transmitter Inverted Data Input
29	CML-I	TD+	Transmitter Noninverted Data Input
30		GND ¹	Module Ground

1. Module ground pins (GND) are isolated from the module case and chassis ground within the module

2. Shall be pulled up with 4.7 kΩ – 10 kΩ to a voltage between 3.15 V and 3.45 V on the host board

8

3.2 XFP/XFI Reference Model Compliance Points

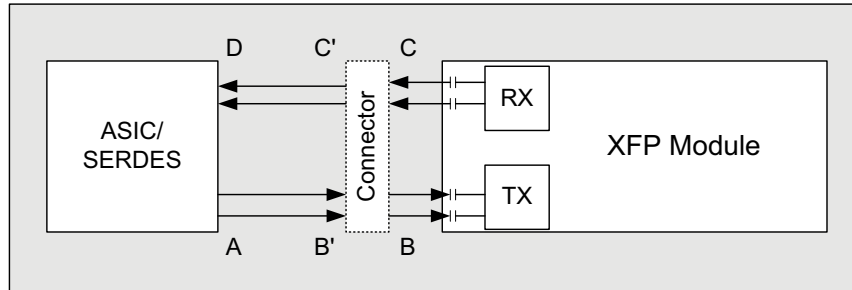

Figure 4 XFP optical transceiver model compliance points

3.3 Absolute Maximum Ratings

Parameter	Symbol	Ratings	Unit
Storage temperature	T_{st}	-40 to +85	°C
Operating case temperature	T_{OP}	-40 to +85	°C
Relative humidity	RH	5 to 85 (noncondensing)	%
Static electrical discharge (Human Body Model)	ESD	500	V
Power supply voltages	$V_{CC3, max}$	-0.3 to 3.63	V
	$V_{CC5, max}$	-0.5 to 6.0	V
Receive input optical power (damage threshold)	P_{dth}	5	dBm

Note:

Absolute maximum ratings represent the damage threshold of the device. Damage may occur if the device is operated above the limits stated here except for brief excursions. Performance is not guaranteed and reliability is not implied for operation at any condition outside the recommended operating limits.

3.4 Operating Conditions

Part Number	SONET/SDH and FEC (9.95 to 11.35 Gbps)	10GbE/10GFC and FEC (9.95 to 11.27 Gbps)	Industrial Temperature (-40°C to 85°C)	Commercial Temperature (-5°C to 70°C)
JXP-01LMAB1	X	X	X	X
JXP-01LMAC1	X	X		X
JXP-01LEAB1		X	X	X
JXP-01LGAB1		X		X

Note:

Performance is not guaranteed and reliability is not implied for operation at any condition outside the recommended operating limits.

9

3.5 Electrical Characteristics

Parameter	Symbol	Minimum	Typical	Maximum	Unit	Notes
Supply currents and voltages						
Voltage3	V_{CC3}	3.13	3.3	3.47	V	With respect to GND
Voltage5	V_{CC5}	4.75	5	5.25	V	With respect to GND
Voltage2	V_{CC2}		1.8		V	Not used
Supply current3	I_{CC3}			750	mA	
Supply current5	I_{CC5}			500	mA	
Supply current2	I_{CC2}		0		mA	VPS; Not used
Power dissipation	Pwr			2.5	W	
Low-speed control and sense signals (detailed specification in XFP MSA INF8077i Rev. 4.5)						
Outputs (Interrupt, Mod_NR, RX_LOS)	V_{OL}	0		0.4	V	Rpullup pulled to host_Vcc, measured at host side of connector. $I_{OL(max)}=3$ mA
	V_{OH}	host_Vcc-0.5		host_Vcc+ 0.3	V	Rpullup pulled to host_Vcc, measured at host side of connector
Inputs (TX_DIS, P_Down/RST, M_DSEL)	V_{IL}	-0.3		0.8	V	Pulled up in module to Vcc3
	V_{IH}	2		$V_{CC3}+ 0.3$	V	Pulled up in module to Vcc3
SCL and SDA Inputs	V_{IL}	-0.3		$V_{CC3}*0.3$	V	Rpullup pulled to host_Vcc, measured at XFP side of connector
	V_{IH}	$V_{CC3}*0.7$		$V_{CC3}+0.5$	V	Rpullup pulled to host_Vcc, measured at XFP side of connector
Transmitter input (detailed specification in XFP MSA INF8077i Rev. 4.5)						
Data input baud rate nominal		9.95		11.35	Gbps	
Data input bit rate tolerance (10GbE/10GFC)		-100		+100	ppm	
Data input bit rate tolerance (SONET/SDH)		-20		+20	ppm	
Data input compliance			B			Internally AC coupled signals
Data input differential impedance	R_I	90	100	110	Ω	
Receiver output (detailed specification in XFP MSA INF8077i Rev. 4.5)						
Data output baud rate nominal		9.95		11.35	Gbps	
Data output compliance			C			internally AC coupled signals
Data output bit rate stability (10GbE/10GFC)		-100		+100	ppm	
Data output bit rate stability (SONET/SDH)		-20		+20	ppm	

10

3.6 Jitter Specifications

Parameter	Symbol	Min	Max	Unit	Notes
Transmitter electrical input jitter from host at B (detailed specification in XFP MSA INF8077i Rev. 4.5)¹					
Total non-EQJ jitter			0.41	UI(p-p)	Total jitter less ISI
Total jitter	TJ		0.61	UI(p-p)	
Eye mask	X1		0.305	UI	Mask coordinate X1=0.205 if total non-DDJ is measured
Eye mask	Y1	60		mV	
Eye mask	Y2		410	mV	50 mV is allocated for multiple reflections
Receiver electrical output jitter to host at C (detailed specification in XFP MSA INF8077i Rev. 4.5)¹					
Deterministic jitter	DJ		0.18	UI(p-p)	Includes jitter transferred from the optical receiver during any valid operational input condition.
Total jitter	TJ		0.34	UI(p-p)	Includes jitter transferred from the optical receiver during any valid operational input condition.
Eye mask	X1		0.17	UI	
Eye mask	X2		0.42	UI	
Eye mask	Y1	170		mV	
Eye mask	Y2		425	mV	
Telecom module optical transmitter and receiver jitter (detailed specification in XFP MSA INF8077i Rev. 4.5 and GR-253-CORE Issue 4-2005)²					
Jitter transfer bandwidth BW			8	MHz	PRBS 2 ³¹ -1, OC-192 / SDH-64 Sinusoidal Jitter Tolerance Mask
Jitter peaking			1	dB	Frequency >120 KHz
Transmitter jitter generation			0.3	UI _{pp}	20 KHz to 80 MHz
			0.1	UI _{pp}	4 MHz to 80 MHz
Datacom module optical transmitter and receiver jitter (detailed specification in XFP MSA INF8077i Rev. 4.5)¹					
Jitter transfer bandwidth BW			8	MHz	PRBS 2 ³¹ -1, Data or scrambled 64 B/66 B as detailed in IEEE 802.3-2005 Clause 52
Jitter peaking			1	dB	Frequency >50 KHz

1. Specifications are applicable to all Part Numbers listed in Section 3.4.

2. Specifications are applicable to SONET / SDH compliant Part Numbers listed in Section 3.4 only.

3.7 Timing Requirement of Control and Status I/O

Parameter	Symbol	Min	Max	Unit	Notes
TX_DIS assert time	t _{off}		10	µsec	Rising edge of TX_DIS to fall of output signal below 10% of nominal
TX_DIS negate time	t _{on}		2	msec	Falling edge of TX_DIS to rise of output signal above 90% of nominal
Time to initialize	t _{init}		300	msec	From power on or from falling edge of P_Down/RST
Interrupt assert delay	Interrupt _{on}		200	msec	From occurrence of the condition triggering Interrupt.
Interrupt negate delay	Interrupt _{off}		500	µsec	From clear on read Interrupt flags
P_Down/RST assert delay	P_Down/RST _{on}		100	µsec	From power down initiation
Mod_NR assert delay	Mod_NR _{on}		1	msec	From occurrence of fault to assertion of Mod_NR
Mod_NR negate delay	Mod_NR _{off}		1	msec	From clearance of signal to negation of Mod_NR
P-Down reset time		10		µsec	Min. length of P-Down assert to initiate reset
RX_LOS assert delay	t _{loss_{on}}		100	µsec	From Occurrence of loss of signal to assertion of RX_LOS
RX_LOS negate delay	t _{loss_{off}}		100	µsec	From Occurrence of return of signal to negation of RX_LOS

Note:

Two-wire serial bus timing is described in Chapter 4 of XFP MSA INF8077i Rev. 4.5.

3.8 XFP Two-wire Interface Protocol and Management Interface

The 10 Gbps 1310 nm multiprotocol XFP optical transceiver incorporates a XFP compliant two-wire management interface which is used for serial ID, digital diagnostics, and certain control functions. It is modeled on the SFF-8472 Rev 9.3 specification modified to accommodate a single two-wire interface address. In addition to the basic I2C read/write functionality, the modules support packet error checking that, when enabled, allows the host system to confirm the validity of any read data. Details of the protocol and interface are explicitly described in the MSA. Please refer to the MSA for design reference.

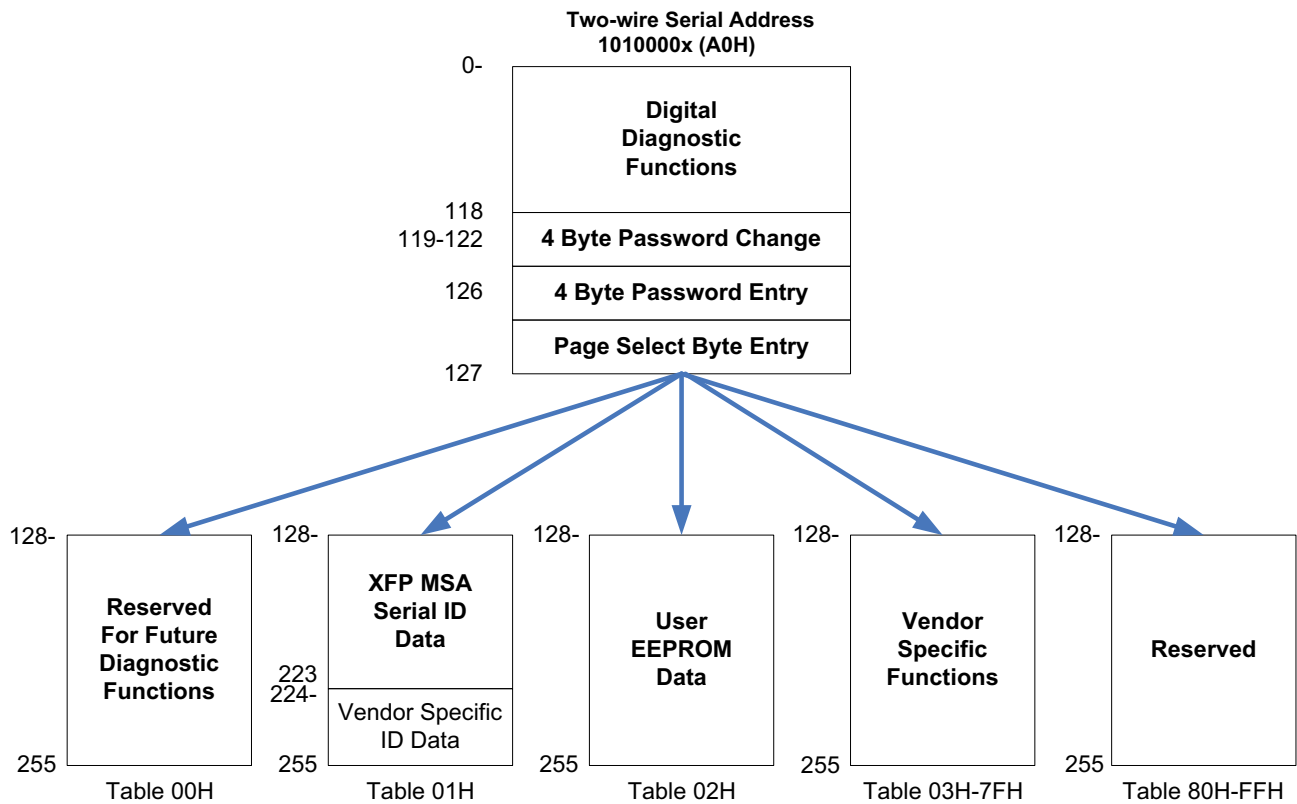

Figure 5 XFP two-wire serial digital diagnostic memory map

12

3.9 Optical Transmitter Characteristics

Parameter	Symbol	Minimum	Typical	Maximum	Unit
Center wavelength	λ	1290		1330	nm
-20 dB spectral width	$\Delta\lambda$			1	nm
Sidemode suppression ratio	SSR	30			dB
Relative intensity noise	$RIN_{12}OMA$			-128	dB/Hz
Average optical power (SONET/SDH) (EOL)	P_{avg}	-6.0		-1.0	dBm
Extinction ratio ¹ (SONET/SDH)	ER	6	7		dB
Chromatic dispersion penalty	P_{CD}			6.6	ps/nm
Optical path penalty	DP			1.0	dB
Return loss tolerance				14	dB
Datacom module optical transmitter characteristics²					
OMA (optical modulation amplitude)	OMA	-5.2			dBm
Transmitter and dispersion penalty	TDP			3.9	dB
Average optical power (10GbE/10GFC) (EOL)	P_{avg}	-8.2		0.5	dBm
Extinction ratio ¹ (10GbE/10GFC)	ER	3.5			dB

1. Tested with PRBS 2³¹-1 pattern

2. Applicable to non SONET/SDH compliant Part Numbers listed in Section 3.4 only.

3.10 Optical Receiver Characteristics

Parameter	Symbol	Minimum	Typical	Maximum	Unit
Center wavelength	λ	1260		1600	nm
Receiver sensitivity ¹	R_{sen}			-14.4	dBm
Stressed receive sensitivity ²	SRS			-10.3	dBm
Receive overload ³	P_{max}	1			dBm
Receiver reflectance	R_{rx}			-14	dB
LOS assert	P_{los_on}	-30		-20	dBm
LOS deassert	P_{los_off}			-18.5	dBm
LOS hysteresis		0.5		6	dB

Note: Specifications are applicable to the operating temperature range listed in Section 3.4

1. Guaranteed at 10.709 Gbps. Measured with worst ER; BER < 10⁻¹²; 2³¹-1 PRBS. Equivalent to -12.6 dBm OMA at ER = 6 dB.

2. Guaranteed at 11.35 Gbps.

3. Guaranteed up to 10.709 Gbps.

3.11 Regulatory Compliance

The 10 Gbps 1310 nm multiprotocol XFP optical transceiver is lead-free and RoHS 6/6 compliant per Directive 2002/95/EC of the European Parliament and of the Council of 27 January 2003 on the restriction of the use of certain hazardous substances in electrical and electronic equipment.

The JDSU 10 Gbps 1310 nm multiprotocol XFP optical transceiver complies with international electromagnetic compatibility (EMC) and international safety requirements and standards. EMC performance is dependent on the overall system design. Information included herein is intended as a figure of merit for designers to use as a basis for design decisions.

Table 2 Regulatory Compliance

Feature	Test Method	Performance
Component safety	UL 60950 UL94-V0 EN 60950	UL Certificate UL Certificate TUV Report/Certificate (CB Scheme)
RoHS-compliance	Directive 2002/95/EC	Compliant per the Directive 2002/95/EC of the European Parliament and of the Council of 27 January 2003 on the restriction of the use of certain hazardous substances in electrical and electronic equipment.
Laser eye safety	EN 60825 U.S. 21CFR (J) 1040.10	TUV Certificate CDRH compliant and Class 1 laser safe.
Electromagnetic Compatibility		
Electromagnetic emissions	EMC Directive 89/336/EEC FCC CFR47 Part 15 IEC/CISPR 22 AS/NZS CISPR22 EN 55022 ICES-003, Issue 4 VCCI-03	Noise frequency range: 30 MHz to 40 GHz. Good system EMI design practice required to achieve Class B margins.
Electromagnetic immunity	EMC Directive 89/336/EEC IEC /CISPR/24 EN 55024	
ESD immunity	EN 61000-4-2	Exceeds requirements. Withstands discharges of; 8 kV contact, 15 kV air
Radiated immunity	EN 61000-4-3	Exceeds requirements. Field strength of 10 V/m RMS, from 10 MHz to 1 GHz. No effect on transmitter/receiver performance is detectable between these limits.

3.12 PCB Layout

Recommended PCB layout is given in XFP MSA INF8077i Rev. 4.5.

14

3.13 Module Outline

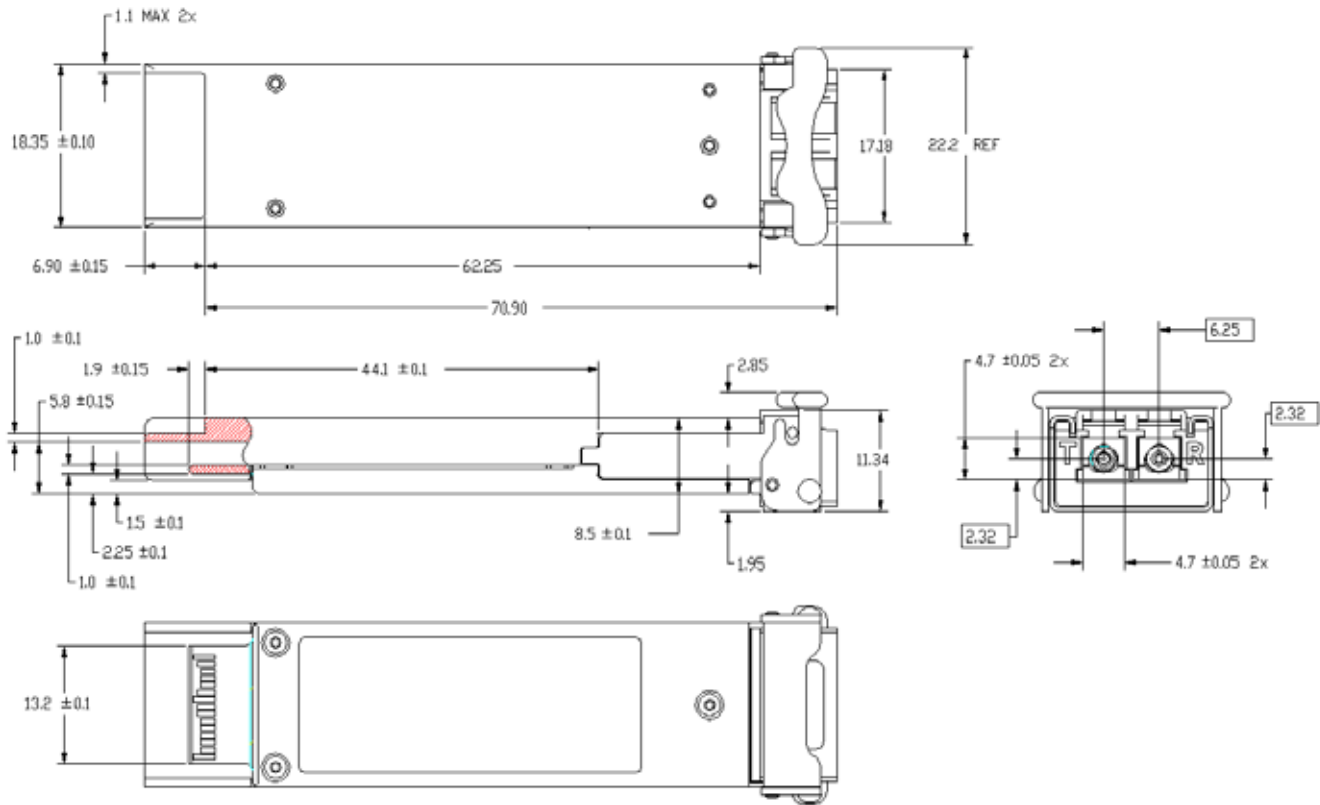

3.14 Connectors

Fiber

The XFP module has a duplex LC receptacle connector.

Electrical

The electrical connector is the 30-way, two-row PCB edge connector. Customer connector is Tyco/AMP Part No. 788862C or equivalent.

Section 4 Related Information

Other information related to the 10 Gbps 1310 nm multiprotocol XFP optical transceiver includes:

- Section 4.1 Packing and Handling Instructions
- Section 4.2 ESD Discharge (ESD)
- Section 4.3 Eye Safety

4.1 Package and Handling Instructions

Connector covers

The 10 Gbps 1310 nm multiprotocol XFP optical transceiver is supplied with an LC duplex receptacle. The connector plug supplied protects the connector during standard manufacturing processes and handling by preventing contamination from dust, aqueous solutions, body oils, or airborne particles.

Note: It is recommended that the connector plug remain on whenever the transceiver optical fiber connector is not inserted.

Recommended cleaning and degreasing chemicals

JDSU recommends the use of methyl, isopropyl and isobutyl alcohols for cleaning.

Do not use halogenated hydrocarbons (trichloroethane, ketones such as acetone, chloroform, ethyl acetate, MEK, methylene chloride, methylene dichloride, phenol, N-methylpyrrolidone).

This product is not designed for aqueous wash.

Housing

The 10 Gbps 1310 nm multiprotocol XFP optical transceiver housing is made from zinc.

4.2 ESD Discharge (ESD)

Handling

Normal ESD precautions are required during the handling of this module. This transceiver is shipped in ESD protective packaging. It should be removed from the packaging and otherwise handled in an ESD protected environment utilizing standard grounded benches, floor mats, and wrist straps.

Test and operation

In most applications, the optical connector will protrude through the system chassis and be subjected to the same ESD environment as the system. Once properly installed in the system, this transceiver should meet and exceed common ESD testing practices and fulfill system ESD requirements.

Typical of optical transceivers, this module's receiver contains a highly sensitive optical detector and amplifier which may become temporarily saturated during an ESD strike. This could result in a short burst of bit errors. Such an event might require that the application reacquire synchronization at the higher layers (serializer/deserializer chip).

4.3 Eye Safety

The JDSU 10 Gbps 1310 nm multiprotocol XFP optical transceiver is an international Class 1 laser product per IEC 60825-1 second edition 2007. The product also complies with U.S.A. regulations for Class 1 products contained in 21 CFR 1040.10 and 1040.11. Laser emissions from Class 1 laser products are not considered hazardous when operated within the limits of this specification.

Operating this product in a manner inconsistent with intended usage and specification may result in hazardous radiation exposure.



CLASS 1 LASER PRODUCT

Caution

Tampering with this laser based product or operating this product outside the limits of this specification may be considered an act of “manufacturing,” and will require, under law, recertification of the modified product with the U.S. Food and Drug Administration (21 CFR 1040).

Ordering Information

For more information on this or other products and their availability, please contact your local JDSU account manager or JDSU directly at 1-800-498-JDSU (5378) in North America and +800-5378-JDSU worldwide, or via e-mail at customer.service@jdsu.com.

Sample: JXP-01LMAB1

Product Code	Description
JXP-01LMAB1	Multiprotocol, OC-192 SR-1, 10 GbE/FC LR/LW, 1310 nm, industrial temperature range 10 Gbps XFP optical transceiver
JXP-01LMAC1	Multiprotocol, OC-192 SR-1, 10 GbE/FC LR/LW, 1310 nm, commercial temperature range 10 Gbps XFP optical transceiver
JXP-01LEAB1	10 GbE/FC LR/LW, 1310 nm, industrial temperature range 10 Gbps XFP optical transceiver
JXP-01LGAB1	10 GbE/FC LR/LW, 1310 nm, commercial temperature range 10 Gbps XFP optical transceiver

NORTH AMERICA: 800 498-JDSU (5378)

WORLDWIDE: +800 5378-JDSU

WEBSITE: www.jdsu.com