

FIBER OPTIC RECEIVING MODULE
TORX179PL

FIBER OPTIC RECEIVING MODULE FOR
 DIGITAL AUDIO INTERFACE

- Conform to JEITA Standard CP-1201 (For Digital Audio Interfaces including Fiber Optic inter-connections).
- Mini package type with Shutter System

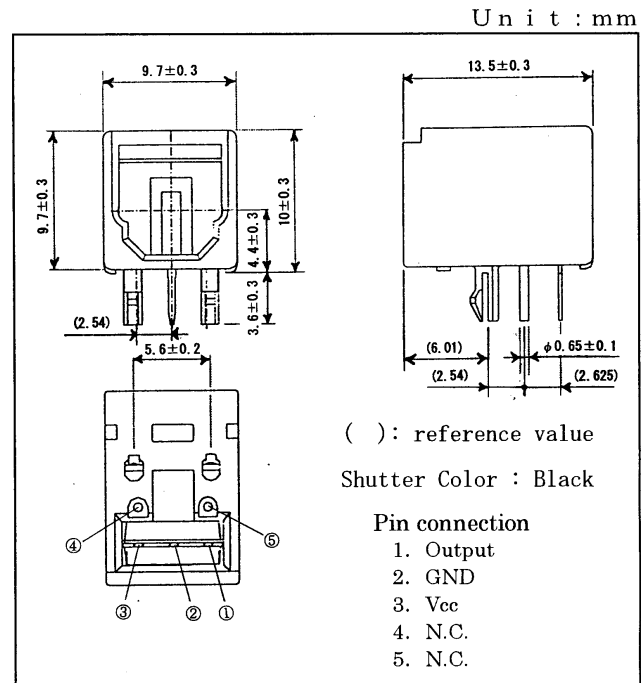

1. Maximum Ratings (Ta=25°C)

ITEM	SYMBOL	RATING	UNIT
Storage Temperature	Tstg	-40 to 70	°C
Operating Temperature	Topr	-20 to 70	°C
Supply Voltage	Vcc	-0.5 to 7	V
High Level Output Current	I _{OH}	-1	mA
Low Level Output Current	I _{OL}	5	mA
Soldering Temperature	Tsol	260 ⁽¹⁾	°C

Note ⁽¹⁾ Soldering time ≤ 10 seconds. (At a distance of 1 mm from the package)

2. Recommended Operating Conditions

ITEM	SYMBOL	MIN.	TYP.	MAX.	UNIT
Supply Voltage	Vcc	4.75	5.00	5.25	V

3. Electrical and Optical Characteristics (Ta=25°C, Vcc=5V)

ITEM	SYMBOL	CONDITION	MIN.	TYP.	MAX.	UNIT
Date Rate		NRZ code ⁽²⁾	0.1	—	12.8	Mb/s
Transmission Distance		Using APF ⁽³⁾ and TOTX179PL	0.2	—	5	m
Pulse Width Distortion ⁽⁴⁾	Δtw	Pulse Width 78ns Pulse Cycle 156ns CL=10pF Using TOTX179PL	-25	—	25	ns
Maximum Receivable Power ⁽⁵⁾	P _{MAX.}	12.8Mb/s, Using APF	-14.5	—	—	dBm
Minimum Receivable Power ⁽⁵⁾	P _{MIN.}	12.8Mb/s, Using APF	—	—	-24	dBm
Current Consumption	I _{cc}		—	22	40	mA
High Level Output Voltage	V _{OH}		3.6	4.0	—	V
Low Level Output Voltage	V _{OL}		—	0.2	0.4	V

Note ⁽²⁾ When non-modulated signal (optical all high or all low level signal) is inputted, output signal is not stable. When modulated optical high level signal is received, output signal is high. When modulated optical low level signal is received, output signal is low. The duty factor must be maintained between 25 to 75%.

⁽³⁾ All Plastic Fiber (970/1000 μm)

⁽⁴⁾ Between input of TOTX179PL and output of TORX179PL.

⁽⁵⁾ BER ≤ 1 0⁻⁹, Peak value

4. Mechanical Characteristics (Ta=25°C)

ITEM	CONDITION	MIN.	TYP.	MAX.	UNIT
Mating force	Using TOCP172, Initial value	—	—	39.2	N
Unmating force	Using TOCP172, Initial value	5.9	—	39.2	N

5. Application Circuit

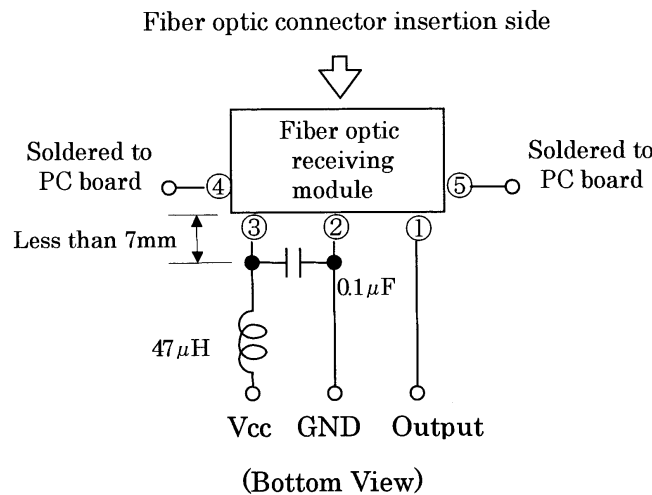

6. Applicable optical fiber with fiber optic connectors.

TOCP172-□□B

7. Foot Layout (reference)

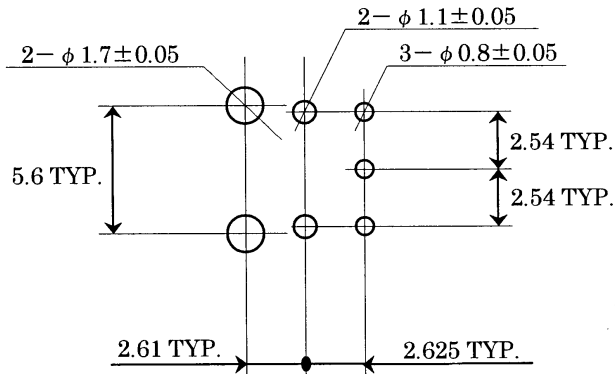

Unit : mm
Recommended PCB thickness : 1.6mm

8. Precaution on Use

(1) Maximum Rating

The maximum ratings are the limit values which must not be exceeded during operation of device. None of these rating value must not be exceeded. If the maximum rating value is exceeded, the characteristics of devices may never be restored. In extreme cases, the device may be permanently damages.

(2) Soldering

Optical modules are comprised of internal semiconductor devices. However, in principle, optical modules are optical components. During soldering, ensure that flux dose not contact with the emitting surface or detecting surface. Also ensure that proper flux removal is conducted after soldering.

Some optical modules come with protective cap. The protective cap is used to avoid malfunction when the optical module is not in use. Note that it is not dust or waterproof. As mentioned before, optical modules are optical components. Thus, in principle, soldering where there may be flux residue or flux removal after soldering is not recommended. Toshiba recommend that soldering be performed without the optical module mounted on the board. Then, after the board has been cleaned, the optical module should be soldered on to the board manually.

If the optical module cannot be soldered manually, use non-halogen (chlorine-free) flux and make sure, without cleaning, there is no residue such as chlorine. This is one of the ways to eliminate the effects of flux. In such a case, check the reliability.

(3) Noise resistance

It is believed that the use of optical transfer devices improve noise resistance. In theory, optical fiber is not affected by noise at all. However, receiving modules which handle signals whose level is extremely small, are susceptible to noise.

TOSLINK improve noise resistance to use a conductive case. However, the current signal output by the optical receiving module's photodiode is extremely small. Thus, in some environments, shielding the case may not achieve sufficient noise resistance.

For systems which incorporate TOSLINK, Toshiba recommend testing using the actual device to check its noise resistance.

Use a simple noise filter on the TOSLINK fiber optic transceiving module's power line. If the ripple in the power supply used is significant, reinforce the filter.

The optical module is to be used in an area which is susceptible to radiated noise, increase the shielding by covering the optical module and the power line filter with a metallic cover .

(4) Vibration and Shock

This module is plastic sealed and has its wire fixed by resin. This structure is relatively resistant to vibration and shock. In actual equipment, there are sometime cases in which vibration, shock, or stress is applied to soldered parts or connected parts, resulting in line cut. A care must be taken in the design of equipment which will be subject to high levels of vibration. for applications which are subject to large amounts of vibration.

(5) Support Pin

The optical receiving module TORX179PL has support pins in order to fix itself to the PCB temporary. Please make the hole for these pins in the PCB under the condition described in board layout hole pattern.

(6) Attaching the fiber optic receiving module

Solder the fixed pins (pins 4 and 5) of the fiber optic receiving module TORX179PL to the printed circuit board in order to fix it to the board.

(7) Solvent

When using solvent for flux removal, do not use a high acid or high alkali solvent. Be careful not to pour solvent in to the optical connector ports. If solvent is inadvertently poured in to them, clean it off using cotton tips.

(8) Supply voltage

Use the supply voltage within the recommended operating condition ($V_{cc}=5\pm 0.25V$). Make sure that supply voltage does not exceed the maximum rating value of 7V, even for an instant.

(9) Interface

The optical receiving module TORX179PL has a TTL interface. It can be interfaced with any TTL-compatible C-MOS IC.

(10) Output

If the receiver output is at low and is connected to the power supply, or if the output is high and is connected to GND, the internal IC may be destroyed.

(11) Soldering condition

Solder at 260°C or less for no more than ten seconds.

(12) Case(receptacle) material

The case is made of polycarbonate. Polycarbonate is usually stable with acid, alcohol, and aliphatic hydrocarbons however, with petrochemicals (such as benzene, toluene, and acetone), alkali, aromatic hydrocarbons, or chloric hydrocarbons, polycarbonate becomes cracked, swollen, or melted. Please take care when choosing a packaging material by referencing the table below. (Chemicals to avoid with polycarbonate)

	P H E N O M E N O N	C H E M I C A L S
A	Little deterioration But staining	• nitric acid(low concentration), hydrogen peroxide, chlorine
B	Cracked, crazed, or Swollen	• acetic acid(70% or more) • gasoline • methyl ethyl ketone, ethyl acetate, butyl acetate • ethyl methacrylate, ethyl ether, MEK • acetone, m-amino alcohol, carbon tetrachloride • carbon disulfide, trichloroethylene, cresol • thinners, oil of turpentine • triethanolamine
C	Melted { } : used as solvent	• concentrated sulfuric acid • benzene • styrene, acrylonitrile, vinyl acetate • ethylenediamine, diethylenediamine • {chloroform, methyl chloride, tetrachloromethane, dioxane} {1,2-dichloroethane}
D	Decomposed	• ammonia water • other alkali

(13) Precautions when disposing of devices and packing materials

When discarding devices and packing materials, follow the procedures stipulated by local regulations in order to protect the environment against contamination.

Compound semiconductors such as GaAs are used LED materials in this module. When devices are disposed of, worker safety and protection of the environment must be taken into account.

(14) Precautions during use

Toshiba is continually working to improve the quality and the reliability of their products. Nevertheless, semiconductor devices in general can malfunction or fail due to their inherent electrical sensitivity and their vulnerability to physical stress. It is the responsibility of the buyer, when utilizing Toshiba products, to observe standards of safety, and to avoid situations in which a malfunction or failure of a Toshiba product could cause loss of human life, bodily injury or damage to property.

When developing equipment, please ensure that Toshiba products are used within specified operating ranges as set forth in the most recent product specifications. Also, please keep in mind the precautions and conditions set forth in the Toshiba Semiconductor Reliability Handbook.

- TOSHIBA is continually working to improve the quality and reliability of its products. Nevertheless, semiconductor devices in general can malfunction or fail due to their inherent electrical sensitivity and vulnerability to physical stress. It is the responsibility of the buyer, when utilizing TOSHIBA products, to comply with the standards of safety in making a safe design for the entire system, and to avoid situations in which a malfunction or failure of such TOSHIBA products could cause loss of human life, bodily injury or damage to property. In developing your designs, please ensure that TOSHIBA products are used within specified operating ranges as set forth in the most recent TOSHIBA products specifications. Also, please keep in mind the precautions and conditions set forth in the "Handling Guide for Semiconductor Devices," or "TOSHIBA Semiconductor Reliability Handbook" etc..
- The TOSHIBA products listed in this document are intended for usage in general electronics applications (computer, personal equipment, office equipment, measuring equipment, industrial robotics, domestic appliances, etc.). These TOSHIBA products are neither intended nor warranted for usage in equipment that requires extraordinarily high quality and/or reliability or a malfunction or failure of which may cause loss of human life or bodily injury ("Unintended usage"). Unintended Usage include atomic energy control instruments, airplane or spaceship instruments, transportation instruments, traffic signal instruments, combustion control instruments, medical instruments, all types of safety devices, etc.. Unintended Usage of TOSHIBA products listed in this document shall be made at the customer's own risk.
- Gallium arsenide (GaAs) is a substance used in the products described in this document. GaAs dust and fumes are toxic. Do not break, cut or pulverize the product, or use chemicals to dissolve them. When disposing of the products, follow the appropriate regulations. Do not dispose of the products with other Industrial waste or with domestic garbage.
- The information contained herein is presented only as a guide for the applications of our products. No responsibility is assumed by TOSHIBA CORPORATION for any infringements of intellectual property or other rights of the third parties which may result from its use. No license is granted by implication or otherwise under any intellectual property or other rights of TOSHIBA CORPORATION or others.
- The information contained herein is subject to change without notice.