



Features

- Active Mixer with Conversion Gain
- Integrated LO and IF Drivers
- Excellent Linearity
- Broadband 50 Ω Impedance on all Ports
- Low LO-RF Leakage
- Differential or Single Ended Inputs

Benefits

- Small and Thin 16-pin SSOP Package with Exposed Paddle
- Few External Components
- Fully ESD Protected

Application

- UMTS/W-CDMA and ISM Band Transmitter
- Other digital Communication Applications
- High Performance RF Instrumentation

Description

The ATR0787 is a high linearity active mixer which is manufactured using Atmel's advanced Silicon Germanium technology for the use in a variety of high performance requiring RF systems such as digital communications.

This mixer features a frequency range of 2100 MHz to 2500 MHz. It operates from a single 5 V supply and provides 17 dB of conversion gain while requiring only 0 dBm input to the integrated LO driver. An IF and an LO amplifier is also included.

The ATR0787 incorporates internal matching on each RF, IF and LO port to enhance ease of use and to reduce the external components required. The RF and LO inputs can be driven differentially or single ended.

Figure 1. Block Diagram

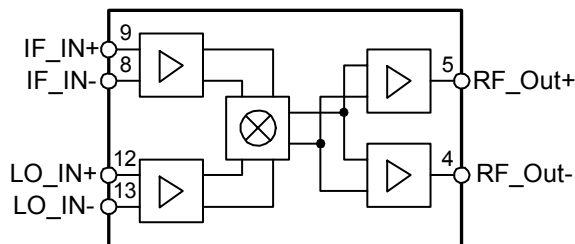

**High Linearity
Active Transmit
Mixer for
2100 MHz to
2500 MHz**

ATR0787

Rev. 4588B-SIGE-02/03



Pin Configuration

Figure 2. Pinning TSSOP16

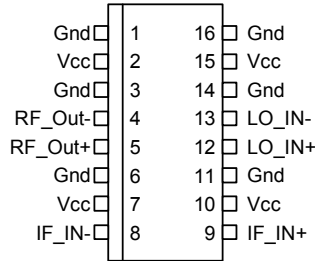

Pin Description

Pin	Symbol	Function
1	GND	Ground
2	Vcc	Supply voltage
3	GND	Ground
4	RF_OUT-	Negative RF output; nominal DC voltage is 2.3 V; (Internally biased) Input should be AC-coupled
5	RF_OUT+	Positive RF output; nominal DC voltage is 2.3 V; (Internally biased) Input should be AC-coupled
6	GND	Ground
7	Vcc	Supply voltage
8	IF_IN-	Negative IF input; nominal DC voltage is 2.3 V, provided through off chip inductors
9	IF_IN+	Positive IF input; nominal DC voltage is 2.3 V, provided through off chip inductors
10	Vcc	Supply voltage
11	GND	Ground
12	LO_IN+	Negative local oscillator input; nominal DC voltage is 2.3 V; (Internally biased) Input should be AC-coupled
13	LO_IN-	Positive local oscillator input; nominal DC voltage is 2.3 V; (Internally biased) Input should be AC-coupled
14	GND	Ground
15	Vcc	Supply voltage
16	GND	Ground
Paddle	–	Device ground and heat sink, requires good thermal path; RF reference plane

Absolute Maximum Ratings

Parameters	Symbol	Value	Unit
Supply voltages, no RF applied	V_{CC}	-0.5 to +5.5	V
LO input signals	LO_IN-; LO_IN+	+10.0	dBm
IF input signals	IF_IN-; IF_IN+	+10.0	dBm
Operating case temperature	T_C	-40 to +85	°C
Storage temperature	T_{STG}	-55 to +150	°C

Thermal Resistance

Parameters	Symbol	Value	Unit
Junction ambient	R_{thJA}	25	K/W

Electrical Characteristics

Test conditions: Unless otherwise noted, the following conditions apply to typical performance specification under static conditions: $V_{CC} = +5.0$ V, $T_{amb} = 25^\circ\text{C}$; $P_{LO} = 0$ dBm; IF = 200 MHz; $P_{IF} = -20$ dBm

No.	Parameters	Test Conditions	Pin	Symbol	Min.	Typ.	Max.	Unit	Type*
General Performance									
	Supply voltage			V_{CC}	4.75	5.0	5.25	V	
	Supply current			I_{CC}		200		mA	
	LO drive	Matched to 50 Ω			-3	0	+3	dBm	
	LO, IF, RF return loss	Matched to 50 Ω				14		dB	

*) Type means: A = 100% tested, B = 100% correlation tested, C = Characterized on samples, D = Design parameter

RF Electrical Characteristics (2100 MHz to 2300 MHz)

Test conditions: Unless otherwise noted, the following conditions apply to typical performance specification under static conditions: $V_{CC} = +5.0$ V, $T_{amb} = 25^\circ\text{C}$; $P_{LO} = 0$ dBm; IF = 200 MHz; $P_{IF} = -20$ dBm

No.	Parameters	Test Conditions	Pin	Symbol	Min.	Typ.	Max.	Unit	Type*
Mixer RF Performance									
	RF frequency			f_{RF}	2100		2300	MHz	
	LO frequency			f_{LO}	1900		2100	MHz	
	IF frequency			f_{IF}	30	200	400	MHz	
	Conversion gain			G	14	17	19	dB	
	SSB Noise figure			NF		9	11.0	dB	
	Output IP3	IF1 = IF2 = -20 dBm/tone, 1 MHz spacing		OIP3	21	24.5		dBm	
	Output P1dB			P1dB	8	11		dBm	
	Leakage (LO-RF)					-20	-10	dBm	
	Leakage (LO-IF)					-30	-20	dBm	

*) Type means: A = 100% tested, B = 100% correlation tested, C = Characterized on samples, D = Design parameter

RF Electrical Characteristics (2300 MHz to 2500 MHz)

Test conditions: Unless otherwise noted, the following conditions apply to typical performance specification under static conditions: $V_{CC} = +5.0\text{ V}$, $T_{amb} = 25^{\circ}\text{C}$; $P_{LO} = 0\text{ dBm}$; $f_{IF} = 200\text{ MHz}$; $P_{IF} = -20\text{ dBm}$

No.	Parameters	Test Conditions	Pin	Symbol	Min.	Typ.	Max.	Unit	Type*
Mixer RF Performance									
	RF frequency			f_{RF}	2300		2500	MHz	
	LO frequency			f_{LO}	2100		2300	MHz	
	IF frequency			f_{IF}	30	200	400	MHz	
	Conversion gain			G	12	15.5	18	dB	
	SSB Noise figure			NF		9	11.0	dB	
	Output IP3	IF1 = IF2 = -20 dBm/tone, 1 MHz spacing		OIP3	17	21		dBm	
	Output P1dB			P1dB	5	8.5		dBm	
	Leakage (LO-RF)					-20	-10	dBm	
	Leakage (LO-IF)					-30	-20	dBm	

*) Type means: A = 100% tested, B = 100% correlation tested, C = Characterized on samples, D = Design parameter

Typical Performance

Figure 3. Conversion Gain versus Frequency + Temperature

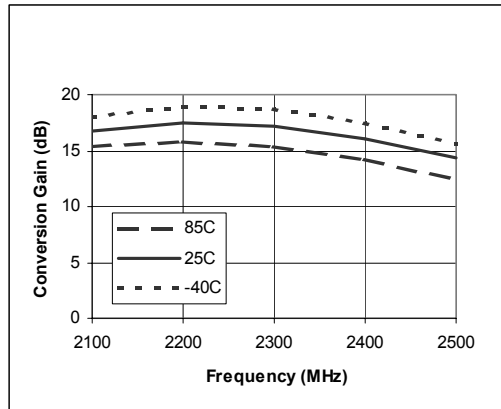

Figure 4. Output IP3 versus Frequency + Temperature

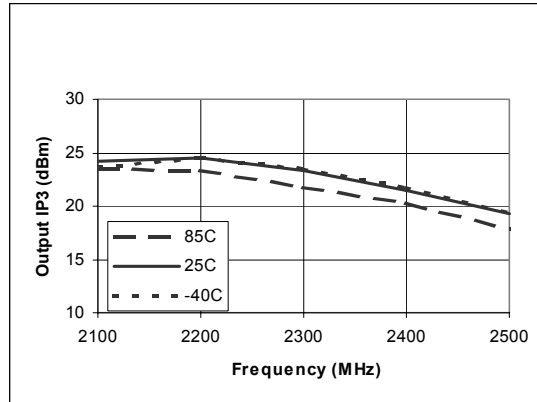

Figure 5. Conversion Gain versus Frequency + LO Drive

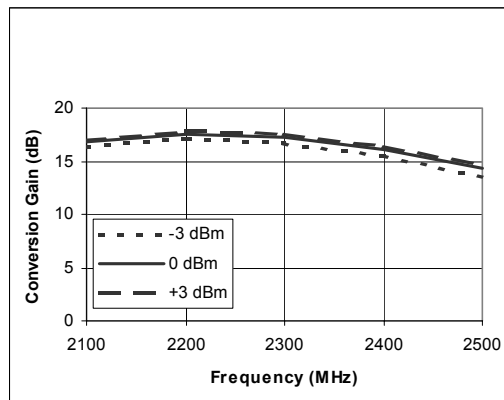

Figure 6. Output IP3 versus Frequency + LO Drive

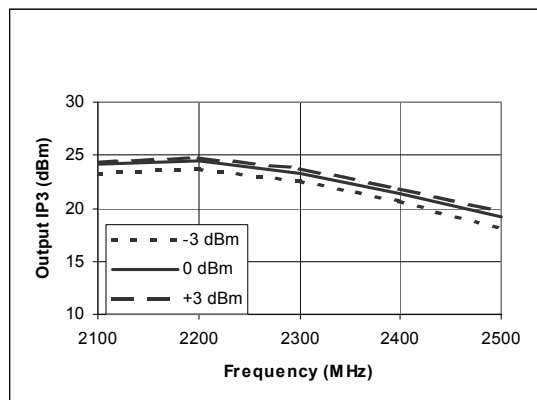

Figure 7. Leakages versus Frequency

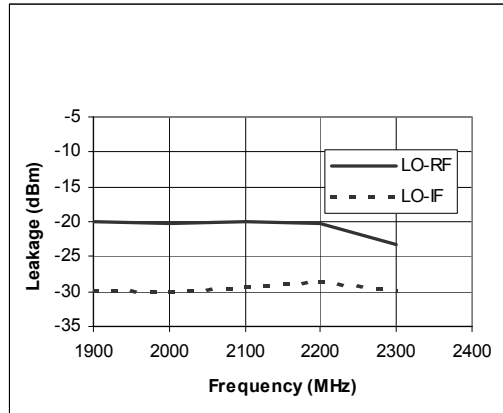

Figure 8. Noise Figure versus Frequency + Temperature

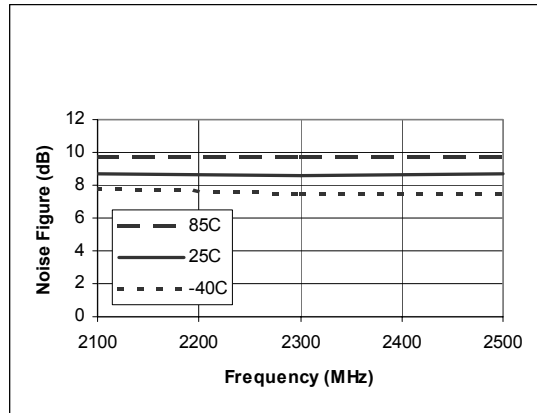

Figure 9. RF and LO Return Loss versus Frequency

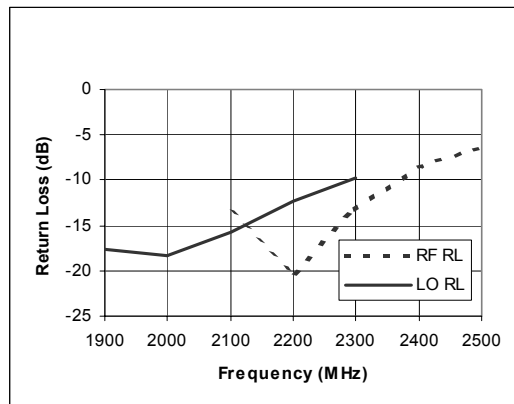

Figure 10. Output P1dB versus Frequency + Temperature

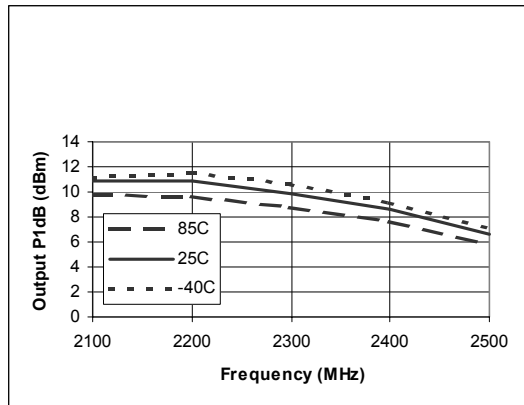

Figure 11. IF Return Loss versus Frequency

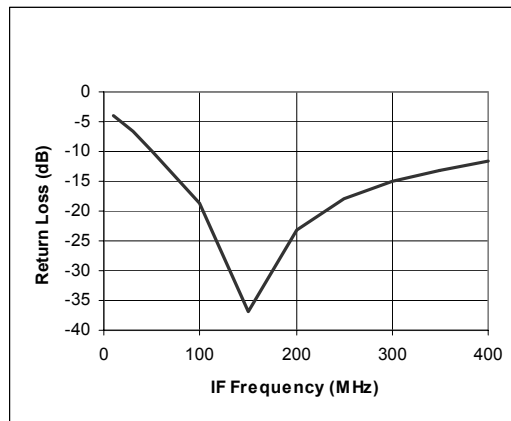

Figure 12. Output P1dB versus Frequency + LO Drive

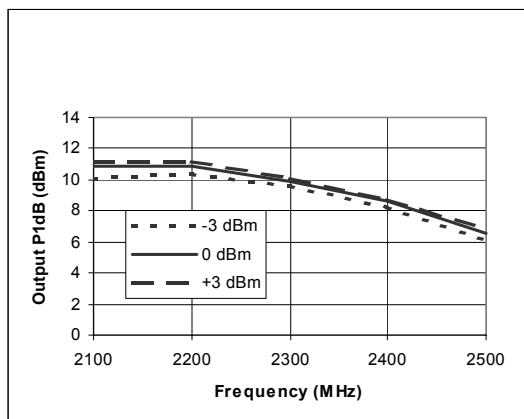
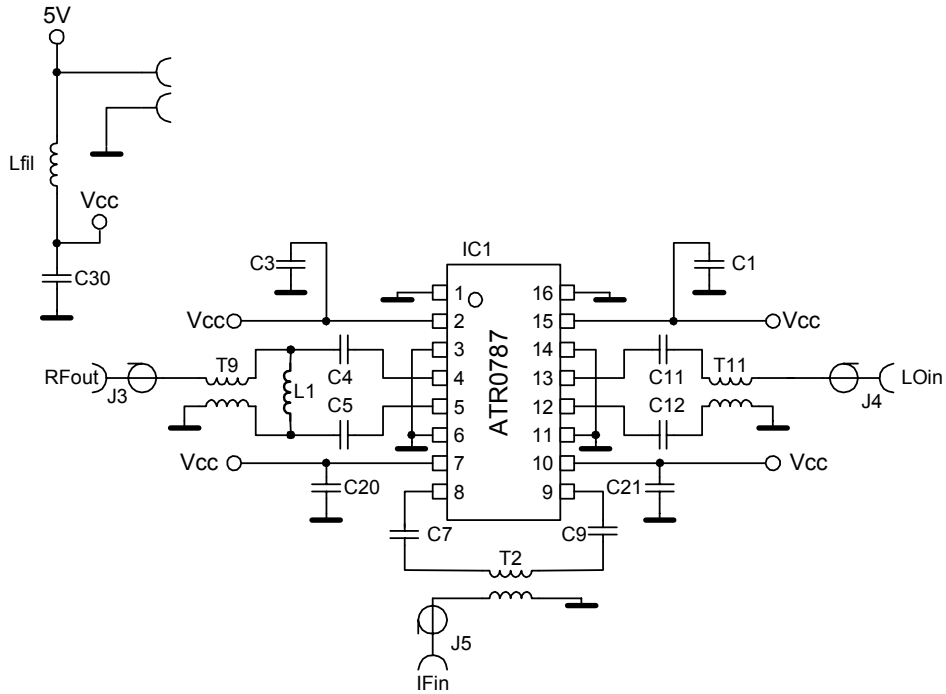

Figure 13. Demo Board Schematic



Bill of Material of Demo Board

Component	Reference	Vendor	Part Number/ Remark	Value	Size/Package ⁽¹⁾
Highly linear active mixer		Atmel	ATR0787		16-pin TSSOP
Capacitor	C7; C9			100 pF	0603
Capacitor	C1; C3; C20; C21; C30			5.6 pF	0603
Capacitor	C11, C12			2.7 pF	0603
Capacitor	C4, C5			1.5 pF	0603
Inductor	Lfil	Würth Elektronik	74476401	1 µH	1210
Inductor	L1	TOKO	LL1608- FS12NJ	12 nH	0603
Transformer	T9; T11	Panasonic	EHF-FD1619		
Transformer	T2	Mini-Circuits®	TC1-1		
RF connector		Johnson Components	142-0701-851		SMA

Note: 1. Other sizes are possible

Figure 14. Demo Test Board

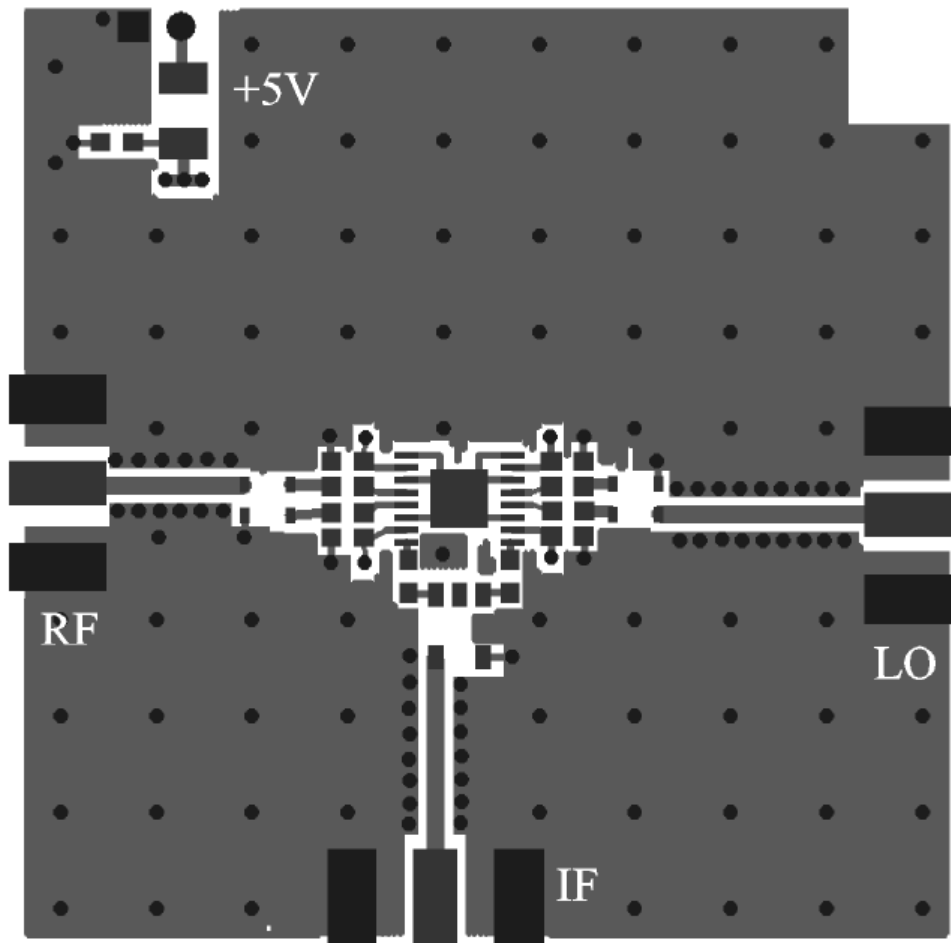

Ordering Information

Extended Type Number	Package	Remarks
ATR0787	TSSOP16	5.0 × 6.4 mm

Package Information

Package: SSOP16
 (acc. JEDEC SMALL OUTLINE No. MO-153)
 Dimensions in mm

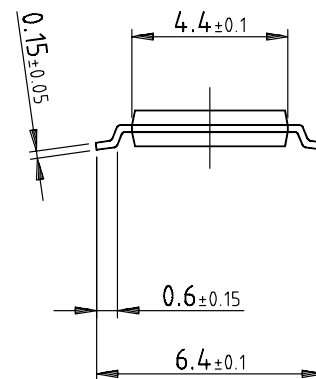
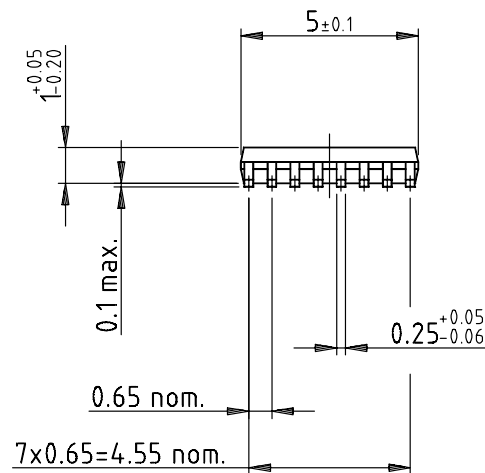
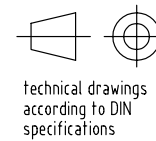
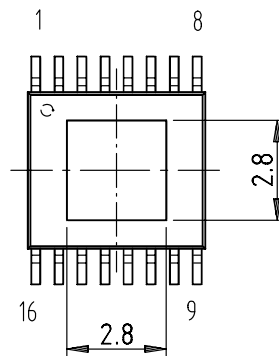

Drawing-No.: 6.543-5079.01-4
 Issue: 1; 10.07.01



Atmel Headquarters

Corporate Headquarters

2325 Orchard Parkway
San Jose, CA 95131
TEL 1(408) 441-0311
FAX 1(408) 487-2600

Europe

Atmel Sarl
Route des Arsenaux 41
Case Postale 80
CH-1705 Fribourg
Switzerland
TEL (41) 26-426-5555
FAX (41) 26-426-5500

Asia

Room 1219
Chinachem Golden Plaza
77 Mody Road Tsimhatsui
East Kowloon
Hong Kong
TEL (852) 2721-9778
FAX (852) 2722-1369

Japan

9F, Tonetsu Shinkawa Bldg.
1-24-8 Shinkawa
Chuo-ku, Tokyo 104-0033
Japan
TEL (81) 3-3523-3551
FAX (81) 3-3523-7581

Atmel Operations

Memory

2325 Orchard Parkway
San Jose, CA 95131
TEL 1(408) 441-0311
FAX 1(408) 436-4314

Microcontrollers

2325 Orchard Parkway
San Jose, CA 95131
TEL 1(408) 441-0311
FAX 1(408) 436-4314

La Chantrerie
BP 70602
44306 Nantes Cedex 3, France
TEL (33) 2-40-18-18-18
FAX (33) 2-40-18-19-60

ASIC/ASSP/Smart Cards

Zone Industrielle
13106 Rousset Cedex, France
TEL (33) 4-42-53-60-00
FAX (33) 4-42-53-60-01

1150 East Cheyenne Mtn. Blvd.
Colorado Springs, CO 80906
TEL 1(719) 576-3300
FAX 1(719) 540-1759

Scottish Enterprise Technology Park
Maxwell Building
East Kilbride G75 0QR, Scotland
TEL (44) 1355-803-000
FAX (44) 1355-242-743

RF/Automotive

Theresienstrasse 2
Postfach 3535
74025 Heilbronn, Germany
TEL (49) 71-31-67-0
FAX (49) 71-31-67-2340

1150 East Cheyenne Mtn. Blvd.
Colorado Springs, CO 80906
TEL 1(719) 576-3300
FAX 1(719) 540-1759

Biometrics/Imaging/Hi-Rel MPU/ High Speed Converters/RF Datacom

Avenue de Rochepleine
BP 123
38521 Saint-Egreve Cedex, France
TEL (33) 4-76-58-30-00
FAX (33) 4-76-58-34-80

e-mail
literature@atmel.com

Web Site
<http://www.atmel.com>

© Atmel Corporation 2003.

Atmel Corporation makes no warranty for the use of its products, other than those expressly contained in the Company's standard warranty which is detailed in Atmel's Terms and Conditions located on the Company's web site. The Company assumes no responsibility for any errors which may appear in this document, reserves the right to change devices or specifications detailed herein at any time without notice, and does not make any commitment to update the information contained herein. No licenses to patents or other intellectual property of Atmel are granted by the Company in connection with the sale of Atmel products, expressly or by implication. Atmel's products are not authorized for use as critical components in life support devices or systems.

Atmel® is the registered trademark of Atmel.

Other terms and product names may be the trademarks of others.



Printed on recycled paper.

4588B-SIGE-02/03

xM