

## Features

- 16-channel GPS Correlator
  - 8192 Search Bins with GPS Acquisition Accelerator
  - Accuracy: 2.5m CEP (2D, Stand Alone)
  - Time to First Fix: 34s (Cold Start)
  - Acquisition Sensitivity: –142 dBm (Cold Start, With External LNA)
  - Tracking Sensitivity: –158 dBm (With External LNA)
- Utilizes the ARM7TDMI® ARM® Thumb® Processor Core
  - High-performance 32-bit RISC Architecture
  - EmbeddedICE™ (In-Circuit Emulation)
- 128 Kbytes Internal RAM
- 384 Kbytes Internal ROM with u-blox GPS Firmware SuperSense®
- 1.5-bit ADC On-chip
- Single IF Architecture
- 2 External Interrupts
- 24 User-programmable I/O Lines
- 1 USB Device Port
  - Universal Serial Bus (USB) 2.0 Full-speed Device
  - Embedded USB V2.0 Full-speed Transceiver
- 2 USARTs
- Master/Slave SPI Interface
  - 4 External Slave Chip Selects
- Programmable Watchdog Timer
- Advanced Power Management Controller (APMC)
  - Geared Master Clock to Reduce Power Consumption
  - Sleep State with Disabled Master Clock
  - Hibernate State with 32.768 kHz Master Clock
- Real Time Clock (RTC)
- 1.8V to 3.3V User-definable IO Voltage for Several GPIOs with 5V Tolerance
- 4 KBytes of Battery Backup Memory
- 7 mm × 10 mm 96 Pin BGA Package, 0.8 mm Pitch, Pb-free, RoHS-compliant

## Benefits

- Fully Integrated Design With Low BOM
- No External Flash Memory Required
- Supports NMEA®, UBX Binary and RTCM Protocol for DGPS
- Supports SBAS (WAAS, EGNOS, MSAS)
- Up to 4 Hz Update Rate
- Supports A-GPS (Aiding)
- Excellent Noise Performance



## ANTARIS4 Single-chip GPS Receiver SuperSense

ATR0635



## 1. Description

The ATR0635 is a low-power, single-chip GPS receiver, especially designed to meet the requirements of mobile applications. It is based on Atmel®'s ANTARIS®4 technology and integrates an RF front-end, filtering, and a baseband processor in a single, tiny 7 mm × 10 mm 96 pin BGA package. Providing excellent RF performance with low noise figure and low power consumption.

Due to the fully integrated design, just an RF SAW filter, a GPS TCXO and blocking capacitors are required to realize a stand-alone GPS functionality.

The ATR0635 includes a complete GPS firmware, licensed from u-blox AG, which performs the GPS operation, including tracking, acquisition, navigation and position data output. For normal PVT (Position/Velocity/Time) applications, there is no need for external Flash- or ROM-memory.

The firmware supports e.g. the NMEA protocol (2.1 and 2.3), a binary protocol for PVT data, configuration and debugging, the RTCM protocol for DGPS, SBAS (WAAS, EGNOS and MSAS) and A-GPS (aiding). It is also possible to store the configuration settings in an optional external EEPROM.

Due to the integrated ARM7TDMI processor and an intelligent radio architecture, the ATR0635 operates in a complete autonomous mode, utilizing on chip AGC in closed loop operation.

For maximum performance, we recommend to use the ATR0635 together with a low noise amplifier (e.g. ATR0610).

The ATR0635 supports assisted GPS.

## 2. Architectural Overview

### 2.1 Block Diagram

Figure 2-1. ATR0635 Block Diagram

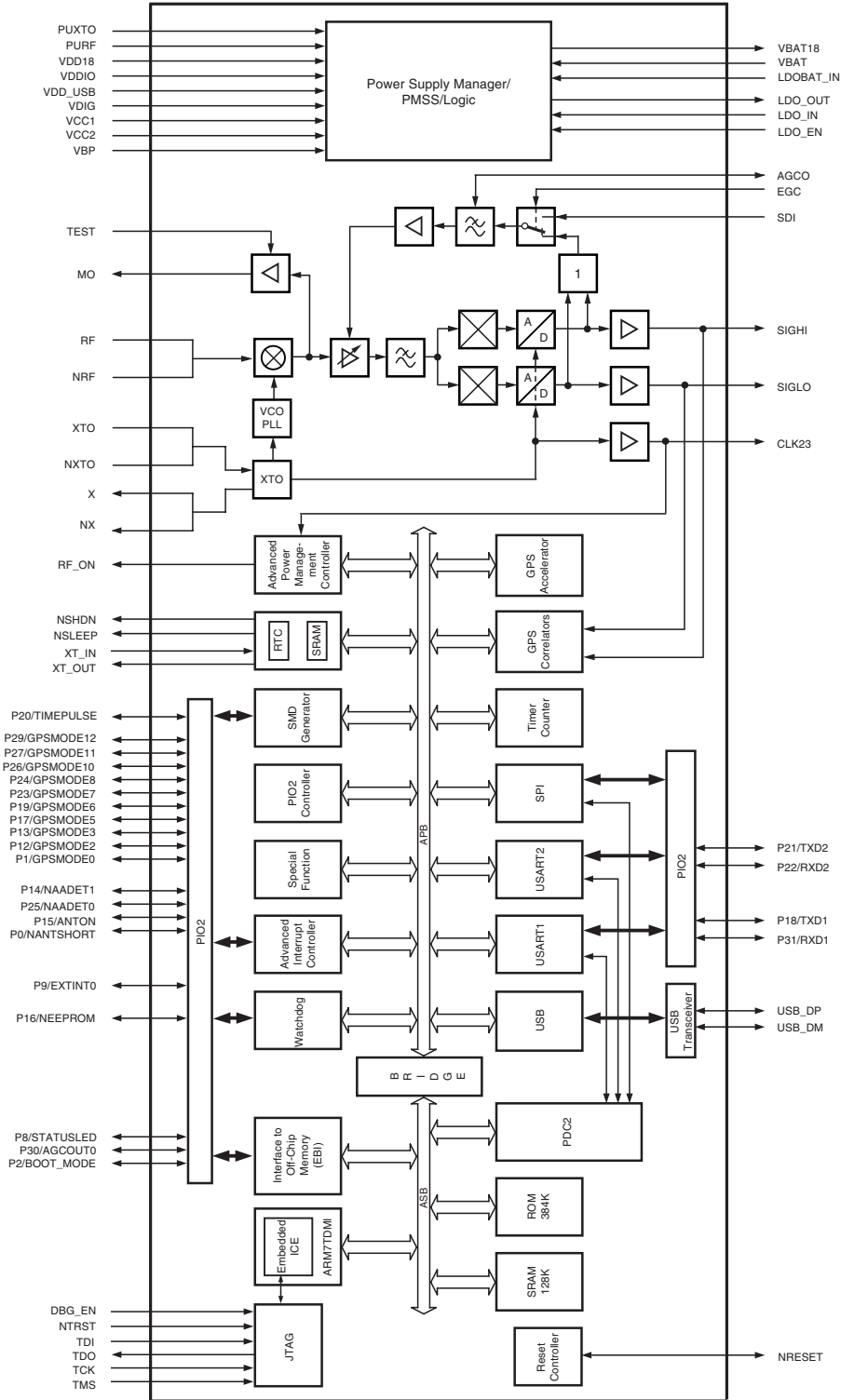

## 2.2 General Description

The ATR0635 has been designed especially for mobile applications. It provides high isolation between GPS and cellular bands, as well as very low power consumption.

ATR0635 is based on the successful ANTARIS4 technology which includes the ANTARIS high performance SuperSense software in ROM, developed by u-blox AG, Switzerland. ANTARIS provides a proven navigation engine which is used in high-end car navigation systems, automatic vehicle location (AVL), security and surveying systems, traffic control, road pricing, and speed camera detectors, and provides location-based services (LBS) worldwide.

The ANTARIS4 chipset has a very low power consumption and comes with a very low BoM for the passive components. Also, as the high performance software SuperSense is available in ROM, no external flash memory is needed.

The L1 input signal ( $f_{RF}$ ) is a Direct Sequence Spread Spectrum (DSSS) signal with a center frequency of 1575.42 MHz. The digital modulation scheme is Bi-Phase-Shift-Keying (BPSK) with a chip rate of 1.023 Mbps.

## 2.3 PMSS Logic

The power management, startup and shutdown (PMSS) logic ensures reliable operation within the recommended operating conditions. The external power control signals PUF and PUXto are passed through Schmitt trigger inputs to eliminate voltage ripple and prevent undesired behavior during start-up and shut-down. Digital and analog supply voltages are analyzed by a monitoring circuit, enabling the startup of the IC only when it is within a safe operating range.

## 2.4 VCO/PLL

The frequency synthesizer features a balanced VCO and a fully integrated loop filter, thus no external components are required. The VCO combines very good phase noise behavior and excellent spurious suppression. The relation between the reference frequency ( $f_{TCXO}$ ) and the VCO center frequency ( $f_{VCO}$ ) is given by:

$$f_{VCO} = f_{TCXO} \times 64 = 23.104 \text{ MHz} \times 64 = 1478.656 \text{ MHz}.$$

## 2.5 RF Mixer/Image Filter

Combined with the antenna, an external LNA provides a first band-path filtering of the signal. Atmel's ATR0610 is recommended for the LNA due to its low noise figure, high linearity and low power consumption. The output of the LNA drives a SAW filter, which provides image rejection for the mixer and the required isolation to all GSM bands. The output of the SAW filter is fed into a highly linear mixer with high conversion gain and excellent noise performance.

## 2.6 VGA/AGC

The on-chip automatic gain control (AGC) stage sets the gain of the VGA in order to optimally load the input of the following analog-to-digital converter. The AGC control loop can be selected for on-chip closed-loop operation or for baseband controlled gain mode.

## 2.7 Analog-to-digital Converter

The analog-to-digital converter stage has a total resolution of 1.5 bits. It comprises balanced comparators and a sub-sampling unit, clocked by the reference frequency ( $f_{TCXO}$ ). The frequency spectrum of the digital output signal ( $f_{OUT}$ ), present at the data outputs SIGLO and SIGH1, is 4.348 MHz.

## 2.8 Baseband

The GPS baseband core includes a 16-channel correlator and is based on an ARM7TDMI ARM processor core with very low power consumption. It has a high-performance 32 bit RISC architecture, uses a high-density 16-bit instruction set. The ARM standard In-Circuit Emulation debug interface is supported via the JTAG/ICE port of the ATR0635.

The ATR0635 architecture consists of two main buses, the Advanced System Bus (ASB) and the Advanced Peripheral Bus (APB). The ASB is designed for maximum performance. It interfaces the processor with the on-chip 32-bit memories and the external memories and devices by means of the External Bus Interface (EBI). The APB is designed for accesses to on-chip peripherals and is optimized for low power consumption. The AMBA™ Bridge provides an interface between the ASB and the APB.

An on-chip Peripheral Data Controller (PDC2) transfers data between the on-chip USARTs/SPI and the on- and off-chip memories without processor intervention. Most importantly, the PDC2 removes the processor interrupt handling overhead and significantly reduces the number of clock cycles required for a data transfer. It can transfer up to 64K contiguous bytes without reprogramming the starting address. As a result, the performance of the microcontroller is increased and the power consumption reduced.

All of the external signals of the on-chip peripherals are under the control of the Parallel I/O Controller (PIO2). The PIO2 Controller can be programmed to insert an input filter on each pin or generate an interrupt on a signal change. After reset, the user must carefully program the PIO2 Controller in order to define which peripheral signals are connected with off-chip logic.

The ATR0635 features a Programmable Watchdog Timer.

An Advanced Power Management Controller (APMC) allows for the peripherals to be deactivated individually. Automatic master clock gearing reduces power consumption. A Sleep Mode is available with disabled 23.104 MHz master clock, as well as a Back-up Mode operating 32.768 kHz master clock.

A 32.768 kHz Real Time Clock (RTC), together with a built-in battery back-up SRAM, allows for storage of Almanac, Ephemeris, software configurations to make quick hot- and warm starts.

The ATR0635 includes the full high performance firmware (SuperSense), licensed from u-blox AG, Switzerland. Features of the ROM firmware are described in a software documentation available from u-blox AG, Switzerland.

### 3. Pin Configuration

#### 3.1 Pinout

Figure 3-1. Pinning BGA96 (Top View)

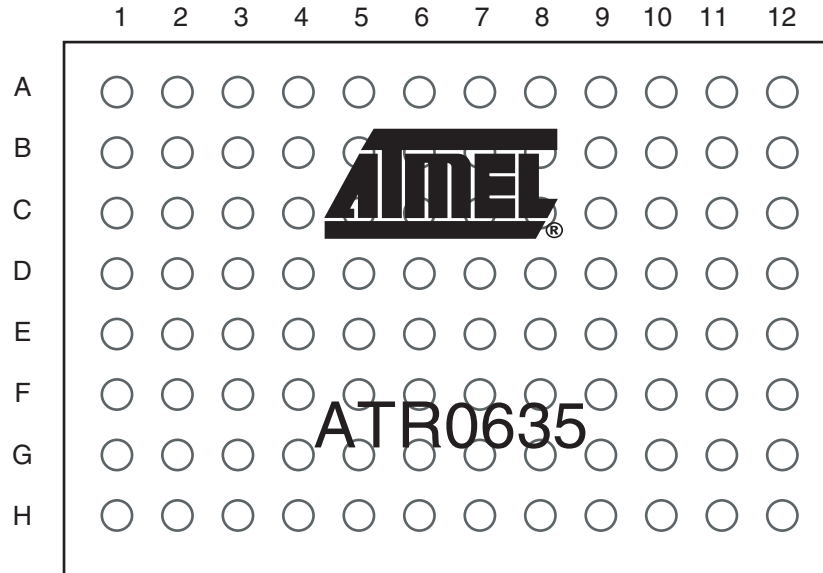

Table 3-1. ATR0635 Pinout

Pin Name	BGA 96	Pin Type	Pull Resistor (Reset Value) <sup>(1)</sup>	Firmware Label	PIO Bank A	
					I	O
AGCO	A4	Analog I/O				
CLK23	A8	Digital OUT				
DBG_EN	E8	Digital IN	PD			
EGC	D4	Digital IN				
GDIG	C5	Supply				
GND	A6	Supply				
GND	A9	Supply				
GND	B11	Supply				
GND	F5	Supply				
GND	H8	Supply				
GND	H12	Supply				
GND A	A3	Supply				
GND A	B1	Supply				

- Notes:
1. PD = internal pull-down resistor, PU = internal pull-up resistor, OH = switched to Output High at reset
  2. VBAT18 represent the internal power supply of the backup power domain, see section “Power Supply” on page 20.
  3. VDD\_USB is the supply voltage for following the USB pins: USB\_DM and USB\_DP, see section “Power Supply” on page 20. For operation of the USB interface, supply of 3.0V to 3.6V is required.
  4. VDDIO is the supply voltage for the following GPIO pins: P1, P2, P8, P12, P14, P16, P17, P18, P19, P20, P21, P23, P24, P25, P26, P27 and P29, see section “Power Supply” on page 20.

**Table 3-1.** ATR0635 Pinout (Continued)

Pin Name	BGA 96	Pin Type	Pull Resistor (Reset Value) <sup>(1)</sup>	Firmware Label	PIO Bank A	
					I	O
GNDA	B4	Supply				
GNDA	D2	Supply				
GNDA	E1	Supply				
GNDA	E2	Supply				
GNDA	E3	Supply				
GNDA	F1	Supply				
GNDA	F2	Supply				
GNDA	F3	Supply				
GNDA	G1	Supply				
GNDA	H1	Supply				
LDOBAT_IN	D11	Supply				
LDO_EN	C11	Digital IN				
LDO_IN	E11	Supply				
LDO_OUT	E12	Supply				
MO	C3	Analog OUT				
NRESET	A7	Digital I/O	Open Drain PU			
NRF	C1	Analog IN				
NSHDN	E9	Digital OUT				
NSLEEP	E10	Digital OUT				
NTRST	H11	Digital IN	PD			
NX	B2	Analog OUT				
NXTO	B3	Analog IN				
P0	C8	Digital I/O	PD	NANTSHORT		
P1	D8	Digital I/O	Configurable (PD)	GPSMODE0		
P2	C6	Digital I/O	Configurable (PD)	BOOT_MODE		'0'
P8	D7	Digital I/O	Configurable (PD)	STATUSLED		'0'
P9	A11	Digital I/O	PU to VBAT18	EXTINT0	EXTINT0	
P12	D6	Digital I/O	Configurable (PU)	GPSMODE2		NPCS2
P13	B10	Digital I/O	PU to VBAT18	GPSMODE3	EXTINT1	
P14	G6	Digital I/O	Configurable (PD)	NAADET1		'0'
P15	F11	Digital I/O	PD	ANTON		
P16	G8	Digital I/O	Configurable (PU)	NEEPROM		
P17	H6	Digital I/O	Configurable (PD)	GPSMODE5	SCK1	SCK1
P18	C7	Digital I/O	Configurable (PU)	TXD1		TXD1
P19	F6	Digital I/O	Configurable (PU)	GPSMODE6		

- Notes:
1. PD = internal pull-down resistor, PU = internal pull-up resistor, OH = switched to Output High at reset
  2. VBAT18 represent the internal power supply of the backup power domain, see section [“Power Supply” on page 20](#).
  3. VDD\_USB is the supply voltage for following the USB pins: USB\_DM and USB\_DP, see section [“Power Supply” on page 20](#). For operation of the USB interface, supply of 3.0V to 3.6V is required.
  4. VDDIO is the supply voltage for the following GPIO pins: P1, P2, P8, P12, P14, P16, P17, P18, P19, P20, P21, P23, P24, P25, P26, P27 and P29, see section [“Power Supply” on page 20](#).



**Table 3-1. ATR0635 Pinout (Continued)**

Pin Name	BGA 96	Pin Type	Pull Resistor (Reset Value) <sup>(1)</sup>	Firmware Label	PIO Bank A	
					I	O
P20	G7	Digital I/O	Configurable (PD)	TIMEPULSE	SCK2	SCK2
P21	E6	Digital I/O	Configurable (PU)	TXD2		TXD2
P22	D10	Digital I/O	PU to VBAT18	RXD2	RXD2	
P23	F8	Digital I/O	Configurable (PU)	GPSMODE7	SCK	SCK
P24	H7	Digital I/O	Configurable (PU)	GPSMODE8	MOSI	MOSI
P25	G5	Digital I/O	Configurable (PD)	NAADET0	MISO	MISO
P26	B6	Digital I/O	Configurable (PU)	GPSMODE10	NSS	NPCS0
P27	F7	Digital I/O	Configurable (PU)	GPSMODE11		NPCS1
P28	E7	Digital I/O	OH			
P29	D5	Digital I/O	Configurable (PU)	GPSMODE12		NPCS3
P30	G12	Digital I/O	PD	AGCOUT0		AGCOUT0
P31	C10	Digital I/O	PU to VBAT18	RXD1	RXD1	
PURF	G4	Digital IN				
PURF	H4	Digital IN				
PUXTO	F4	Digital IN				
RF	D1	Analog IN				
RF_ON	F10	Digital OUT	PD			
SDI	C4	Digital IN				
SIGHI0	B8	Digital OUT				
SIGLO0	B7	Digital OUT				
TCK	G9	Digital IN	PU			
TDI	H10	Digital IN	PU			
TDO	F9	Digital OUT				
TEST	D3	Analog IN				
TMS	G10	Digital IN	PU			
USB_DM	D9	Digital I/O				
USB_DP	C9	Digital I/O				
VBAT	D12	Supply				
VBAT18 <sup>(2)</sup>	C12	Supply				
VBP	G2	Supply				
VBP	G3	Supply				
VBP	H2	Supply				
VBP	H3	Supply				
VCC1	C2	Supply				
VCC2	E4	Supply				

- Notes:
1. PD = internal pull-down resistor, PU = internal pull-up resistor, OH = switched to Output High at reset
  2. VBAT18 represent the internal power supply of the backup power domain, see section [“Power Supply” on page 20](#).
  3. VDD\_USB is the supply voltage for following the USB pins: USB\_DM and USB\_DP, see section [“Power Supply” on page 20](#). For operation of the USB interface, supply of 3.0V to 3.6V is required.
  4. VDDIO is the supply voltage for the following GPIO pins: P1, P2, P8, P12, P14, P16, P17, P18, P19, P20, P21, P23, P24, P25, P26, P27 and P29, see section [“Power Supply” on page 20](#).



**Table 3-1.** ATR0635 Pinout (Continued)

Pin Name	BGA 96	Pin Type	Pull Resistor (Reset Value) <sup>(1)</sup>	Firmware Label	PIO Bank A	
					I	O
VDD_USB <sup>(3)</sup>	A10	Supply				
VDD18	H9	Supply				
VDD18	G11	Supply				
VDD18	F12	Supply				
VDD18	B9	Supply				
VDD18	E5	Supply				
VDDIO <sup>(4)</sup>	B5	Supply				
VDDIO	H5	Supply				
VDIG	A5	Supply				
X	A2	Analog OUT				
XT_IN	A12	Analog IN				
XT_OUT	B12	Analog OUT				
XTO	A1	Analog Input				

- Notes:
1. PD = internal pull-down resistor, PU = internal pull-up resistor, OH = switched to Output High at reset
  2. VBAT18 represent the internal power supply of the backup power domain, see section “Power Supply” on page 20.
  3. VDD\_USB is the supply voltage for following the USB pins: USB\_DM and USB\_DP, see section “Power Supply” on page 20. For operation of the USB interface, supply of 3.0V to 3.6V is required.
  4. VDDIO is the supply voltage for the following GPIO pins: P1, P2, P8, P12, P14, P16, P17, P18, P19, P20, P21, P23, P24, P25, P26, P27 and P29, see section “Power Supply” on page 20.

## 3.2 Signal Description

**Table 3-2.** Signal Description

Pin Number	Pin Name	Type	Active Level	Pin Description/Comment
<b>RF Section</b>				
D1	RF	ANALOG IN	-	Input from SAW filter
C1	NRF	ANALOG IN	-	Inverted input from SAW filter
<b>GPS XTAL Section</b>				
A1	XTO	ANALOG IN	-	TCXO input (23.104 MHz)
B3	NXTO	ANALOG IN	-	Inverted TCXO input (23.104 MHz)
A2	X	ANALOG OUT	-	XTO interface (capacitor)
B2	NX	ANALOG OUT	-	Inverted XTO interface (capacitor)
<b>RTC Section</b>				
A12	XT_IN	ANALOG IN	-	Oscillator input (32.768 kHz)
B12	XT_OUT	ANALOG OUT	-	Oscillator output (32.768 kHz)
<b>Automatic Gain Control, bandwidth setting</b>				
A4	AGCO	ANALOG IO	-	Automatic gain control analog voltage, connect shunt capacitor to GND
D4	EGC	DIGITAL IN	-	Enable external gain control (high = software gain control, low = automatic gain control)
G12	AGCOUT0	DIGITAL OUT	-	Software gain control
C4	SDI	DIGITAL IN	-	Software gain control

**Table 3-2. Signal Description (Continued)**

Pin Number	Pin Name	Type	Active Level	Pin Description/Comment
<b>Boot Section</b>				
C6	BOOT_MODE	DIGITAL IN	-	Leave open, internal pull down
<b>Reset</b>				
A7	NRESET	DIGITAL IN	Low	Reset input; open drain with internal pull-up resistor
<b>APMC/Power Management</b>				
E9	NSHDN	DIGITAL OUT	Low	Shutdown output, connect to LDO_EN (C11)
C11	LDO_EN	DIGITAL IN	-	Enable LDO18
E10	NSLEEP	DIGITAL OUT	Low	Power-up output for GPS XTAL, connect to PUXTO (F4)
F4	PUXTO	DIGITAL IN	-	Power-up input for GPS XTAL
G4, H4	PURF	DIGITAL IN	-	Power-up input for GPS radio
F10	RF_ON	DIGITAL OUT	-	Power-up output for GPS radio, connect to PURF (G4, H4)
<b>Advanced Interrupt Controller (AIC)</b>				
A11, B10	EXTINT0-1	DIGITAL IN	High/Low/ Edge	External interrupt request
<b>USART</b>				
C10, D10	RXD1/RXD2	DIGITAL IN	-	USART receive data
C7, E6	TXD1/TXD2	DIGITAL OUT	-	USART transmit data
H6, G7	SCK1/SCK2	DIGITAL I/O	-	External synchronous serial clock
<b>USB</b>				
C9	USB_DP	DIGITAL I/O	-	USB data (D+)
D9	USB_DM	DIGITAL I/O	-	USB data (D-)
<b>SPI Interface</b>				
F8	SCK	DIGITAL I/O	-	SPI clock
H7	MOSI	DIGITAL I/O	-	Master out slave in
G5	MISO	DIGITAL I/O	-	Master in slave out
B6	NSS/NPCS0	DIGITAL I/O	Low	Slave select
F7, D6, D5	NPCS1/NPCS2 /NPCS3	DIGITAL OUT	Low	Slave select
<b>PIO</b>				
A11, B[6,10], C[6-8,10], D[5-8,10], E[6,7], F[6-8], G[5-8], H[6,7]	P0 to P31	DIGITAL I/O	-	Programmable I/O ports
<b>Configuration</b>				
B[6,10], D[5,6,8], F[6-8], H[6,7]	GPSMODE0-12	DIGITAL IN	-	GPS mode pins
G8	NEEPROM	DIGITAL IN	Low	Enable EEPROM support
GPS				
D7	STATUSLED	DIGITAL OUT	-	Status LED
G7	TIMEPULSE	DIGITAL OUT	-	GPS synchronized time pulse

**Table 3-2. Signal Description (Continued)**

Pin Number	Pin Name	Type	Active Level	Pin Description/Comment
<b>Active Antenna Supervision</b>				
C8	NANTSHORT	DIGITAL IN	Low	Active antenna short detection Input
G5, G6	NAADET0/ NAADET1	DIGITAL IN	Low	Active antenna detection Input
F11	ANTON	DIGITAL OUT	-	Active antenna power-on Output
<b>JTAG Interface</b>				
E8	DBG_EN	DIGITAL IN	-	Debug enable
F9	TDO	DIGITAL OUT	-	Test data out
G9	TCK	DIGITAL IN	-	Test clock
G10	TMS	DIGITAL IN	-	Test mode select
H10	TDI	DIGITAL IN	-	Test data in
H11	NTRST	DIGITAL IN	Low	Test reset input
<b>Debug/Test</b>				
C3	MO	ANALOG OUT	-	IF output buffer
D3	TEST	ANALOG IN	-	Enable IF output buffer
B7	SIGLO	DIGITAL OUT	-	Digital IF (data output "Low")
B8	SIGHI	DIGITAL OUT	-	Digital IF (data output "High")
A8	CLK23	DIGITAL OUT	-	Digital IF (sample clock)
<b>Power Analog Part</b>				
C2	VCC1	SUPPLY	-	Analog supply 3V
E4	VCC2	SUPPLY	-	Analog supply 3V
G2, G3, H2, H3	VBP	SUPPLY	-	Analog supply 3V
A3, B1, B4, D2, E[1-3], F[1-3], G1, H1	GNDA	SUPPLY	-	Analog Ground
<b>Power Digital Part</b>				
A5	VDIG	SUPPLY	-	Digital supply (radio) 1.8V
B9, E5, F12, G11, H9	VDD18	SUPPLY	-	Core voltage 1.8V
A10	VDD_USB	SUPPLY	-	USB transceiver supply voltage (3.0V to 3.6V (USB enabled) or 0 to 2.0V (USB disabled))
B5, H5	VDDIO	SUPPLY	-	Variable I/O voltage 1.65V to 3.6V
C5	GDIG	SUPPLY	-	Digital ground (radio)
A6, A9, B11, F5, H8, H12	GND	SUPPLY	-	Digital ground
<b>LDO18</b>				
E11	LDO_IN	SUPPLY	-	2.3V to 3.6V
E12	LDO_OUT	SUPPLY	-	1.8V LDO18 output, max. 80 mA
<b>LDOBAT</b>				
D11	LDOBAT_IN	SUPPLY	-	2.3V to 3.6V
D12	VBAT	SUPPLY	-	1.5V to 3.6V
C12	VBAT18	SUPPLY	-	1.8V LDOBAT Output



### 3.3 Setting GPSPMODE0 to GPSPMODE12

The start-up configuration of this ROM-based system without external non-volatile memory is defined by the status of the GPSPMODE pins after system reset. Alternatively, the system can be configured through message commands passed through the serial interface after start-up. This configuration of the ATR0635 can be stored in an external non-volatile memory like EEPROM. *Default* designates settings used by ROM firmware if GPSPMODE configuration is disabled (GPSPMODE0 = 0).

**Table 3-3.** GPSPMODE Functions

Pin	Function
GPSPMODE0 (P1)	Enable configuration with GPSPMODE pins
GPSPMODE1 (P9)	This pin (EXTINT0) is used for FixNOW™ functionality and not used for GPSPMODE configuration.
GPSPMODE2 (P12)	GPS sensitivity settings
GPSPMODE3 (P13)	
GPSPMODE4 (P14)	This pin (NAADET1) is used as active antenna supervisor input and not used for GPSPMODE configuration. This is the default selection if GPSPMODE configuration is disabled.
GPSPMODE5 (P17)	Serial I/O configuration
GPSPMODE6 (P19)	
GPSPMODE7 (P23)	USB power mode
GPSPMODE8 (P24)	General I/O configuration
GPSPMODE9 (P25)	This pin (NAADET0) is used as an active Antenna Supervisor input and not used for GPSPMODE configuration
GPSPMODE10 (P26)	General I/O configuration
GPSPMODE11 (P27)	
GPSPMODE12 (P29)	Serial I/O configuration

In the case that GPSPMODE pins with internal pull-up or pull-down resistors are connected to GND/VDD18, additional current is drawn over these resistors. Especially GPSPMODE3 can impact the back-up current.

#### 3.3.1 Enable GPSPMODE Pin Configuration

**Table 3-4.** Enable Configuration With GPSPMODE Pins

GPSPMODE0 (Reset = PD)	Description
0 <sup>(1)</sup>	Ignore all GPSPMODE pins. The default settings as indicated below are used.
1	Use settings as specified with GPSPMODE[2, 3, 5 to 8, 10 to 12]

Note: 1. Leave open

If the GPSPMODE configuration is enabled (GPSPMODE0 = 1) and the other GPSPMODE pins are not connected externally, the reset default values of the internal pull-down and pull-up resistors will be used.

## 3.3.2 Sensitivity Settings

**Table 3-5.** GPS Sensitivity Settings

GPSPMODE3 (Fixed PU)	GPSPMODE2 (Reset = PU)	Description
0 <sup>(1)</sup>	0	Auto mode (Default ROM value)
0 <sup>(1)</sup>	1 <sup>(2)</sup>	Fast mode
1 <sup>(2)</sup>	0	Normal mode
1 <sup>(2)</sup>	1 <sup>(2)</sup>	High sensitivity

Notes: 1. Increased back-up current  
2. Leave open

For all GPS receivers the sensitivity depends on the integration time of the GPS signals. Therefore there is a trade-off between sensitivity and the time to detect the GPS signal (Time to first fix). The three modes, “Fast Acquisition”, “Normal” and “High Sensitivity”, have a fixed integration time. The “Normal” mode, recommended for the most applications, is a trade off between the sensitivity and TTFF. The “Fast Acquisition” mode is optimized for fast acquisition, at the cost of a lower sensitivity. The “High Sensitivity” mode is optimized for higher sensitivity, at the cost of longer TTFF. The “Auto” mode adjusts the integration time (sensitivity) automatically according to the measured signal levels. That means the receiver with this setting has a fast TTFF at strong signals, a high sensitivity to acquire weak signals but some times at medium signal level a higher TTFF as the “Normal” mode. These sensitivity settings affect only the startup performance not the tracking performance.

## 3.4 Serial I/O Configuration

The ATR0635 features a two-stage I/O-message and protocol-selection procedure for the two available serial ports. At the first stage, a certain protocol can be enabled or disabled for a given USART port or the USB port. Selectable protocols are RTCM, NMEA and UBX. At the second stage, messages can be enabled or disabled for each enabled protocol on each port. In all configurations described below, all protocols are enabled on all ports, but output messages are enabled in a way that ports appear to communicate at only one protocol. However, each port will accept any input message in any of the three implemented protocols

**Table 3-6.** Serial I/O Configuration

GPSPMODE12 (Reset = PU)	GPSPMODE6 (Reset = PU)	GPSPMODE5 (Reset = PD)	USART1/USB (Output Protocol/ Baud Rate (kBaud))	USART2 (Output Protocol/ Baud Rate (kBaud))	Messages <sup>(1)</sup>	Information Messages
0	0	0 <sup>(2)</sup>	UBX/57.6	NMEA/19.2	High	User, Notice, Warning, Error
0	0	1	UBX/38.4	NMEA/9.6	Medium	User, Notice, Warning, Error
0	1 <sup>(2)</sup>	0 <sup>(2)</sup>	UBX/19.2	NMEA/4.8	Low	User, Notice, Warning, Error
0	1 <sup>(2)</sup>	1	–/Auto	–/Auto	Off	None
1 <sup>(2)</sup>	0	0 <sup>(2)</sup>	NMEA/19.2	UBX/57.6	High	User, Notice, Warning, Error
1 <sup>(2)</sup>	0	1	NMEA/4.8	UBX/19.2	Low	User, Notice, Warning, Error
1 <sup>(2)</sup>	1 <sup>(2)</sup>	0 <sup>(2)</sup>	NMEA/9.6	UBX/38.4	Medium	User, Notice, Warning, Error
1 <sup>(2)</sup>	1 <sup>(2)</sup>	1	UBX/115.2	NMEA/19.2	Debug	All

Notes: 1. See [Table 3-7](#) to [Table 3-10](#) on page 14, the messages are described in the ANTARIS4 protocol specification  
2. Leave open



Both USART ports accept input messages in all three supported protocols (NMEA, RTCM and UBX) at the configured baud rate. Input messages of all three protocols can be arbitrarily mixed. Response to a query input message will always use the same protocol as the query input message. The USB port does only accept NMEA and UBX as input protocol by default. RTCM can be enabled via protocol messages on demand.

In Auto mode, no output message is sent out by default, but all input messages are accepted at any supported baud rate. Again, USB is restricted to only NMEA and UBX protocols. Response to query input commands will be given by the same protocol and baud rate as it was used for the query command. Using the respective configuration commands, periodic output messages can be enabled.

The following message settings are used in the tables below:

**Table 3-7.** Supported Messages at Setting *Low*

<b>NMEA Port</b>	Standard	GGA, RMC
<b>UBX Port</b>	NAV	SOL, SVINFO
	MON	EXCEPT

**Table 3-8.** Supported Messages at Setting *Medium*

<b>NMEA Port</b>	Standard	GGA, RMC, GSA, GSV, GLL, VTG, ZDA
<b>UBX Port</b>	NAV	SOL, SVINFO, POSECEF, POSLLH, STATUS, DOP, VELECEF, VELNED, TIMEGPS, TIMEUTC, CLOCK

**Table 3-9.** Supported Messages at Setting *High*

<b>NMEA Port</b>	Standard	GGA, RMC, GSA, GSV, GLL, VTG, ZDA, GRS, GST
	Proprietary	PUBX00, PUBX03, PUBX04
<b>UBX Port</b>	NAV	SOL, SVINFO, POSECEF, POSLLH, STATUS, DOP, VELECEF, VELNED, TIMEGPS, TIMEUTC, CLOCK
	MON	SCHD, IO, IPC, EXCEPT

**Table 3-10.** Supported Messages at Setting *Debug* (Additional Undocumented Message May be Part of Output Data)

<b>NMEA Port</b>	Standard	GGA, RMC, GSA, GSV, GLL, VTG, ZDA, GRS, GST
	Proprietary	PUBX00, PUBX03, PUBX04
<b>UBX Port</b>	NAV	SOL, SVINFO, POSECEF, POSLLH, STATUS, DOP, VELECEF, VELNED, TIMEGPS, TIMEUTC, CLOCK
	MON	SCHD, IO, IPC, EXCEPT
	RXM	RAW (RAW message support requires an additional license)

The following settings apply if GPSPMODE configuration is not enabled, that is, GPSPMODE = 0 (ROM defaults):

**Table 3-11.** Serial I/O Default Setting if GPSPMODE Configuration is Deselected (GPSPMODE0 = 0)

	USB NMEA	USART1 NMEA	USART2 UBX
Baud rate (kBaud)		57.6	57.6
Input protocol	UBX, NMEA	UBX, NMEA, RTCM	UBX, NMEA, RTCM
Output protocol	NMEA	NMEA	UBX
Messages	GGA, RMC, GSA, GSV	GGA, RMC, GSA, GSV	NAV: SOL, SVINFO MON: EXCEPT
Information messages (UBX INF or NMEA TXT)	User Notice, Warning, Error	User, Notice, Warning, Error	User, Notice, Warning, Error

### 3.4.1 USB Power Mode

For correct response to the USB host queries, the device has to know its power mode. This is configured via GPSPMODE7. If set to *bus powered*, an upper current limit of 100 mA is reported to the USB host; that is, the device classifies itself as a “low-power bus-powered function” with no more than one USB power unit load.

**Table 3-12.** USB Power Modes

GPSPMODE7 (Reset = PU)	Description
0	USB device is bus-powered (maximum current limit 100 mA)
1 <sup>(1)</sup>	USB device is self-powered (default ROM value)

Note: 1. Leave open

### 3.4.2 Active Antenna Supervisor

The two pins P0/NANTSHORT and P15/ANTON plus one pin of P25/NAADDET0/MISO or P14/NAADDET1 are always initialized as general purpose I/Os and used as follows:

- P15/ANTON is an output which can be used to switch on and off antenna power supply.
- Input P0/NANTSHORT will indicate an antenna short circuit, i.e. zero DC voltage at the antenna, to the firmware. If the antenna is switched off by output P15/ANTON, it is assumed that also input P0/NANTSHORT will signal zero DC voltage, i.e. switch to its active low state.
- Input P25/NAADDET0/MISO or P14/NAADDET1 will indicate a DC current into the antenna. In case of short circuit, both P0 and P25/P14 will be active, i.e. at low level. If the antenna is switched off by output P15/ANTON, it is assumed that also input P25/NAADDET0/MISO will signal zero DC current, i.e. switch to its active low state. Which pin is used as NAADDET (P14 or P25) depends on the settings of GPSPMODE11 and GPSPMODE10 (see [Table 3-14 on page 16](#)).

**Table 3-13.** Pin Usage of Active Antenna Supervisor

Pin	Usage	Meaning
P0/NANTSHORT	NANTSHORT	Active antenna short circuit detection High = No antenna DC short circuit present Low = Antenna DC short circuit present
P25/NAADET0/ MISO or P14/NAADET1	NAADET	Active antenna detection input High = No active antenna present Low = Active antenna is present
P15/ANTON	ANTON	Active antenna power on output High = Power supply to active antenna is switched on Low = Power supply to active antenna is switched off

**Table 3-14.** Antenna Detection I/O Settings

GPSMODE11 (Reset = PU)	GPSMODE10 (Reset = PU)	GPSMODE8 (Reset = PU)	Location of NAADET	Comment
0	0	0	P25/NAADET0/MISO	
0	0	1 <sup>(1)</sup>	P25/NAADET0/MISO	
0	1 <sup>(1)</sup>	0	P14/NAADET1	Reserved for further use. Do not use this setting.
0	1 <sup>(1)</sup>	1 <sup>(1)</sup>	P14/NAADET1 (Default ROM value)	
1 <sup>(1)</sup>	0	0	P14/NAADET1	Reserved for further use. Do not use this setting.
1 <sup>(1)</sup>	0	1 <sup>(1)</sup>	P14/NAADET1	Reserved for further use. Do not use this setting.
1 <sup>(1)</sup>	1 <sup>(1)</sup>	0	P25/NAADET0/MISO	
1 <sup>(1)</sup>	1 <sup>(1)</sup>	1 <sup>(1)</sup>	P25/NAADET0/MISO	

Note: 1. Leave open

The Antenna Supervisor Software will be configured as follows:

1. Enable Control Signal
2. Enable Short Circuit Detection (power down antenna via ANTON if short is detected via NANTSHORT)
3. Enable Open Circuit Detection via NAADET

The antenna supervisor function may not be disabled by GPSMODE pin selection.

If the antenna supervisor function is not used, please leave open ANTON, NANTSHORT and NAADET.



## 3.4.3 External Connections for a Working GPS System

**Figure 3-2.** Example of an External Connection (ATR0635)

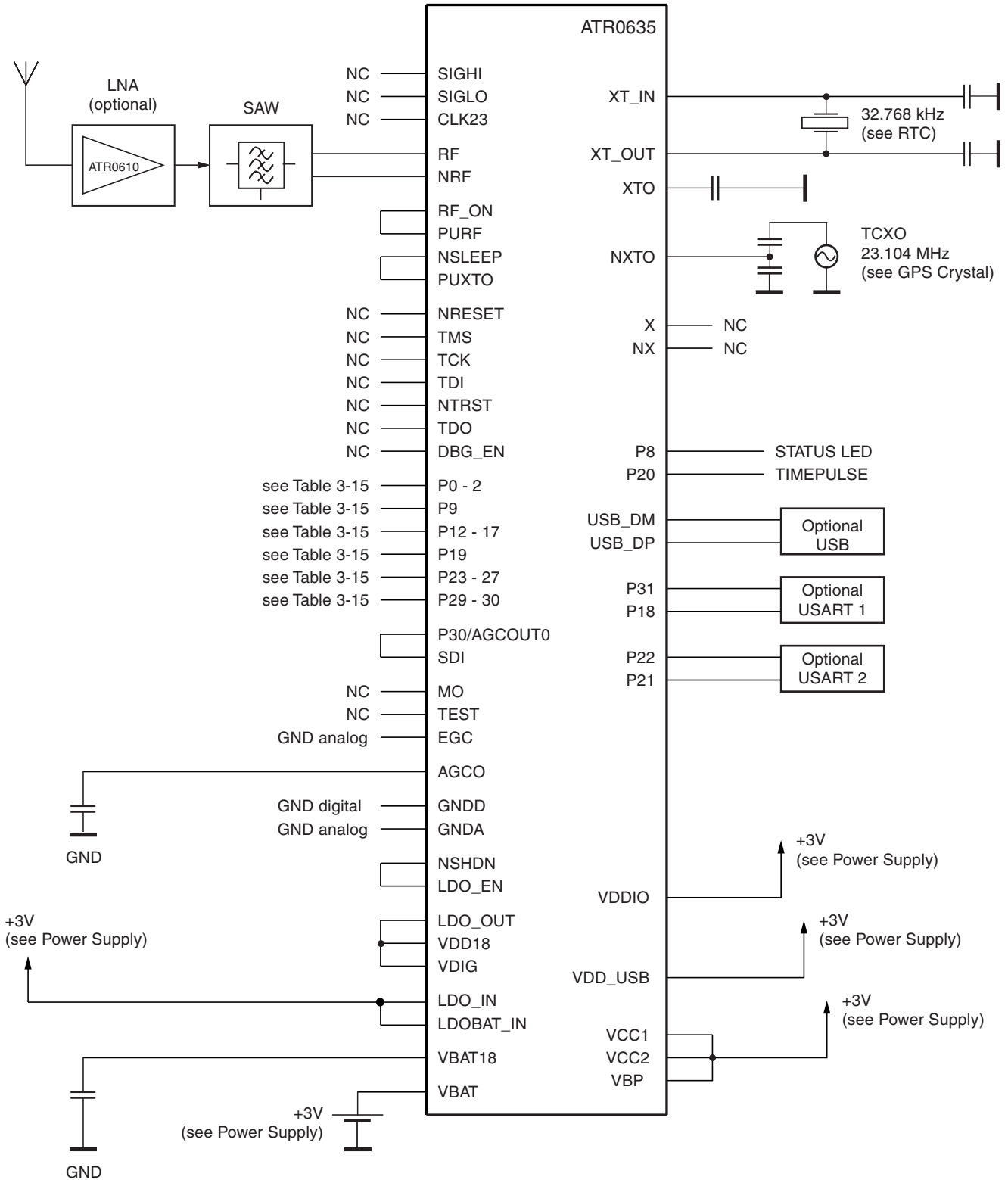

NC: Not connected

**Table 3-15.** Recommended Pin Connections

Pin Name	Recommended External Circuit
P0/NANTSHORT	Internal pull-down resistor; leave open if Antenna Supervision functionality is unused.
P1/GPSMODE0	Internal pull-down resistor; leave open in order to disable the GPSMODE pin configuration feature. Connect to VDD18 to enable the GPSMODE pin configuration feature. Refer to GPSMODE definitions in <a href="#">“Setting GPSMODE0 to GPSMODE12” on page 12.</a>
P2/BOOT_MODE	Internal pull-down resistor; leave open.
P8/STATUSLED	Output in default ROM firmware: leave open if not used
P9/EXTINT0	Internal pull-up resistor; leave open if unused.
P12/GPSMODE2/NPCS2	Internal pull-up resistor; can be left open if the GPSMODE feature is not used. Refer to GPSMODE definitions in <a href="#">“Setting GPSMODE0 to GPSMODE12” on page 12.</a>
P13/GPSMODE3/ EXTINT1	Internal pull-up resistor; can be left open if the GPSMODE feature is not used. Refer to GPSMODE definitions in <a href="#">“Setting GPSMODE0 to GPSMODE12” on page 12.</a>
P14/NAADET1	Internal pull-down resistor; leave open if Antenna Supervision functionality is unused.
P15/ANTON	Internal pull-down resistor; leave open if Antenna Supervision functionality is unused.
P16/NEEPROM	Internal pull-up resistor; leave open if no serial EEPROM is connected. Otherwise connect to GND.
P17/GPSMODE5/SCK1	Internal pull-down resistor; can be left open if the GPSMODE feature is not used. Refer to GPSMODE definitions in <a href="#">“Setting GPSMODE0 to GPSMODE12” on page 12.</a>
P18/TXD1	Output in default ROM firmware: leave open if serial interface is not used.
P19/GPSMODE6/SIGLO1	Internal pull-up resistor; can be left open if the GPSMODE feature is not used. Refer to GPSMODE definitions in <a href="#">“Setting GPSMODE0 to GPSMODE12” on page 12.</a>
P20/TIMEPULSE/SCK2	Output in default ROM firmware: leave open if time pulse feature is not used.
P21/TXD2	Output in default ROM firmware: leave open if serial interface not used.
P22/RXD2	Internal pull-up resistor; leave open if serial interface is not used.
P23/GPSMODE7/SCK	Internal pull-up resistor; can be left open if the GPSMODE feature is not used. Refer to GPSMODE definitions in <a href="#">“Setting GPSMODE0 to GPSMODE12” on page 12.</a>
P24/GPSMODE8/MOSI	Internal pull-up resistor; can be left open if the GPSMODE feature is not used. Refer to GPSMODE definitions in <a href="#">“Setting GPSMODE0 to GPSMODE12” on page 12.</a>
P25/NAADET0/MISO	Internal pull-down resistor; leave open if Antenna Supervision functionality is unused.
P26/GPSMODE10/NSS/ NPCS0	Internal pull-up resistor; can be left open if the GPSMODE feature is not used. Refer to GPSMODE definitions in <a href="#">“Setting GPSMODE0 to GPSMODE12” on page 12.</a>
P27/GPSMODE11/NPCS1	Internal pull-up resistor; can be left open if the GPSMODE feature is not used. Refer to GPSMODE definitions in <a href="#">“Setting GPSMODE0 to GPSMODE12” on page 12.</a>
P29/GPSMODE12/NPCS3	Internal pull-up resistor; can be left open if the GPSMODE feature is not used. Refer to GPSMODE definitions in <a href="#">“Setting GPSMODE0 to GPSMODE12” on page 12.</a>
P30/AGCOUT0	Internal pull-down resistor; leave open.
P31/RXD1	Internal pull-up resistor; leave open if serial interface is not used.

## 3.5 Connecting an Optional Serial EEPROM

The ATR0635 offers the possibility of connecting an external serial EEPROM. The internal ROM firmware supports storing the configuration of the ATR0635 in serial EEPROM. The pin P16/NEEPROM signals the firmware that a serial EEPROM is connected to the ATR0635. The ATR0635's 32-bit RISC processor accesses the external memory via SPI (serial peripheral interface). For best results, use a 32-Kbit 1.8V serial EEPROM such as Atmel's AT25320AY1-1.8. [Figure 3-3](#) shows an example of the serial EEPROM connection.

**Figure 3-3.** Example of a Serial EEPROM Connection

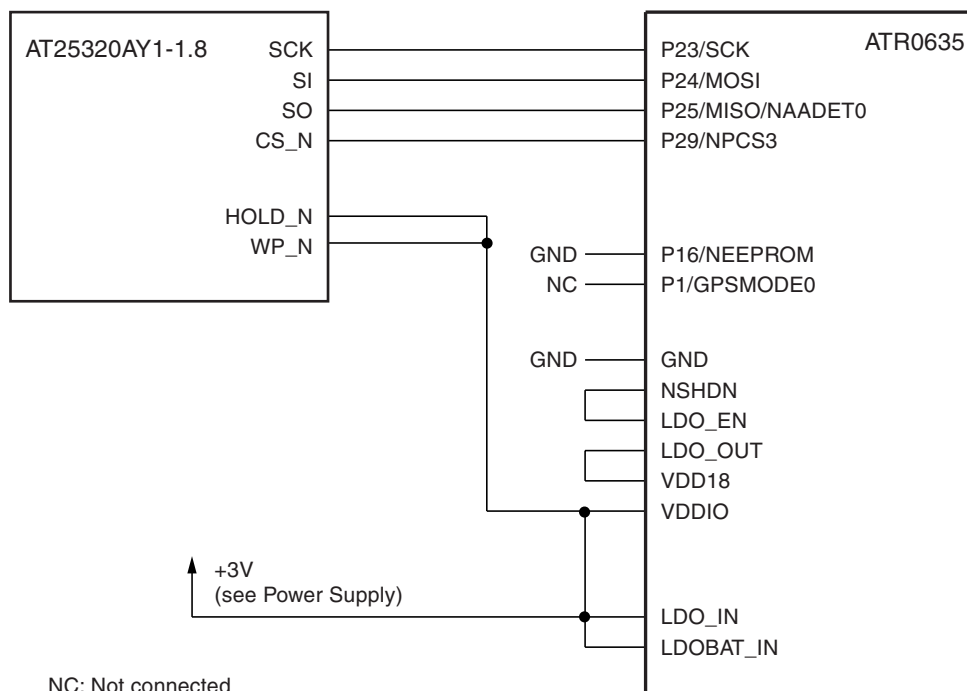

**Note:** The GPSMODE pin configuration feature can be disabled, because the configuration can be stored in the serial EEPROM. VDDIO is the supply voltage for the pins: P23, P24, P25 and P29.

## 4. Power Supply

The ATR0635 is supplied with six distinct supply voltages:

- The power supplies for the RF part (VCC1, VCC2, VBP) within 2.7V to 3.3V.
- VDIG, the 1.8V supply of the digital pins of the RF part (SIGHI, SIGLO and CLK23). VDIG should be connected to VDD18.
- VDD18, the nominal 1.8V supply voltage for the core, the I/O pins, the memory interface and the test pins and all GPIO pins not mentioned in next item.
- VDDIO, the variable supply voltage within 1.8V to 3.6V for the following GPIO pins: P1, P2, P8, P12, P14, P16, P17, P18, P19, P20, P21, P23, P24, P25, P26, P27 and P29. In input mode, these pins are 5V input tolerant.
- VDD\_USB, the power supply of the USB pins: USB\_DM and USB\_DP.
- VBAT18 to supply the backup domain: RTC, backup SRAM and the pins NSLEEP, NSHDN, LDO\_EN, VBAT18, P9/EXTIN0, P13/EXTINT1, P22/RXD2 and P31/RXD1 and the 32kHz oscillator. In input mode, the four GPIO-pins are 5V input tolerant.

**Figure 4-1.** Connecting Example: Separate Power Supplies for RF and Digital Part Using the Internal LDOs

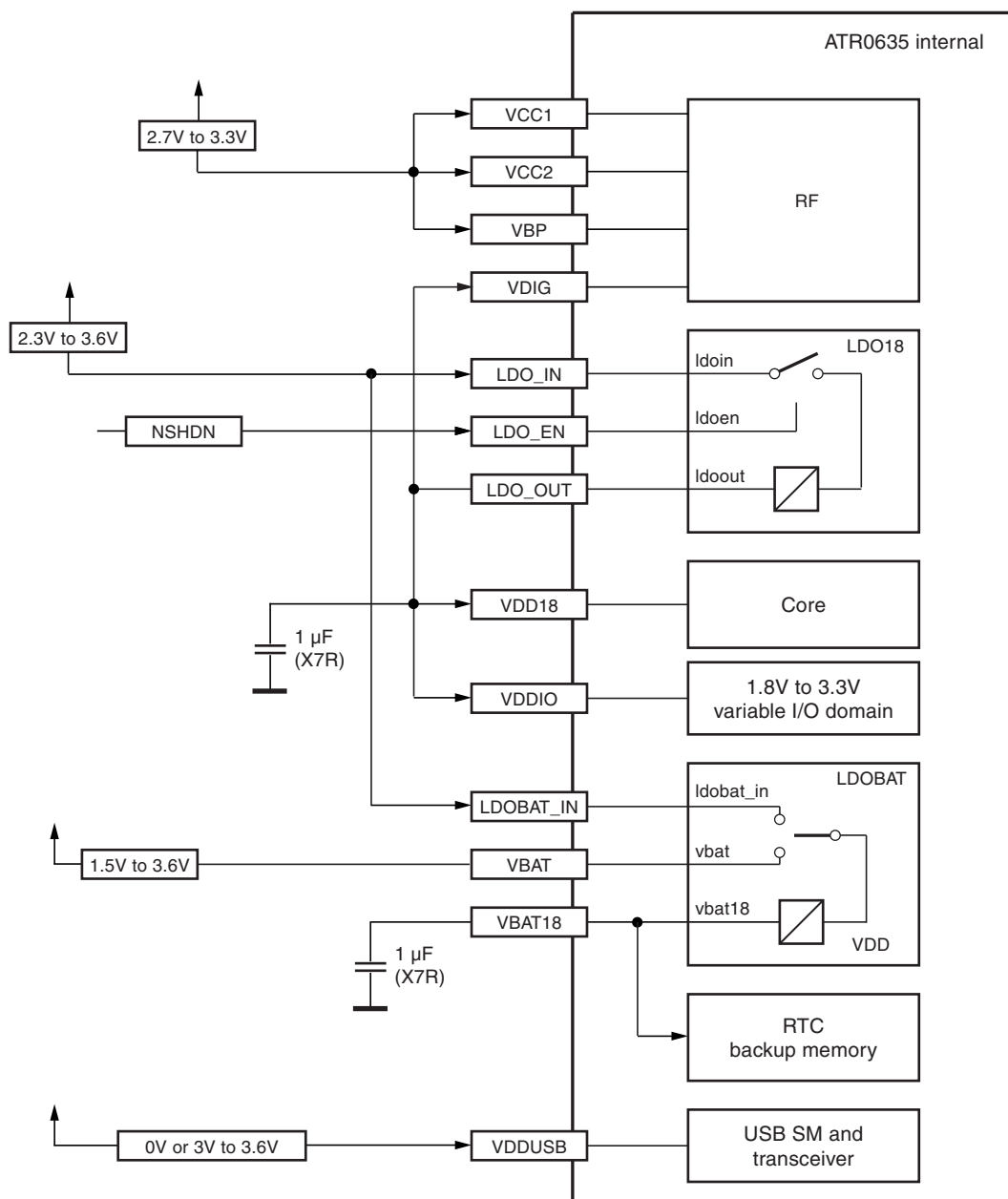

The ATR0635 contains a built in low dropout voltage regulator LDO18. This regulator can be used if the host system does not provide the core voltage VDD18 of 1.8V nominal. In such case, LDO18 will provide a 1.8V supply voltage from any input voltage VDD between 2.3V and 3.6V. The LDO\_EN input can be used to shut down VDD18 if the system is in standby mode.

If the host system does supply a 1.8V core voltage directly, this voltage has to be connected to the VDD18 supply pins of the Core. LDO\_EN must be connected to GND. LDO\_IN can be connected to GND. LDO\_OUT must not be connected.

A second built in low dropout voltage regulator LDOBAT provides the supply voltage for the RTC and backup SRAM from any input voltage VBAT between 1.5V and 3.6V. The backup battery delivers the supply current if LDOBAT\_IN is not powered.

The RTC section will be initialized properly if VDD18 is supplied first to the ATR0635. If VBAT is applied first, the current consumption of the RTC and backup SRAM is undetermined.

**Figure 4-2.** Connecting Example: Common Power Supplies for RF and Digital Part Using the Internal LDOs

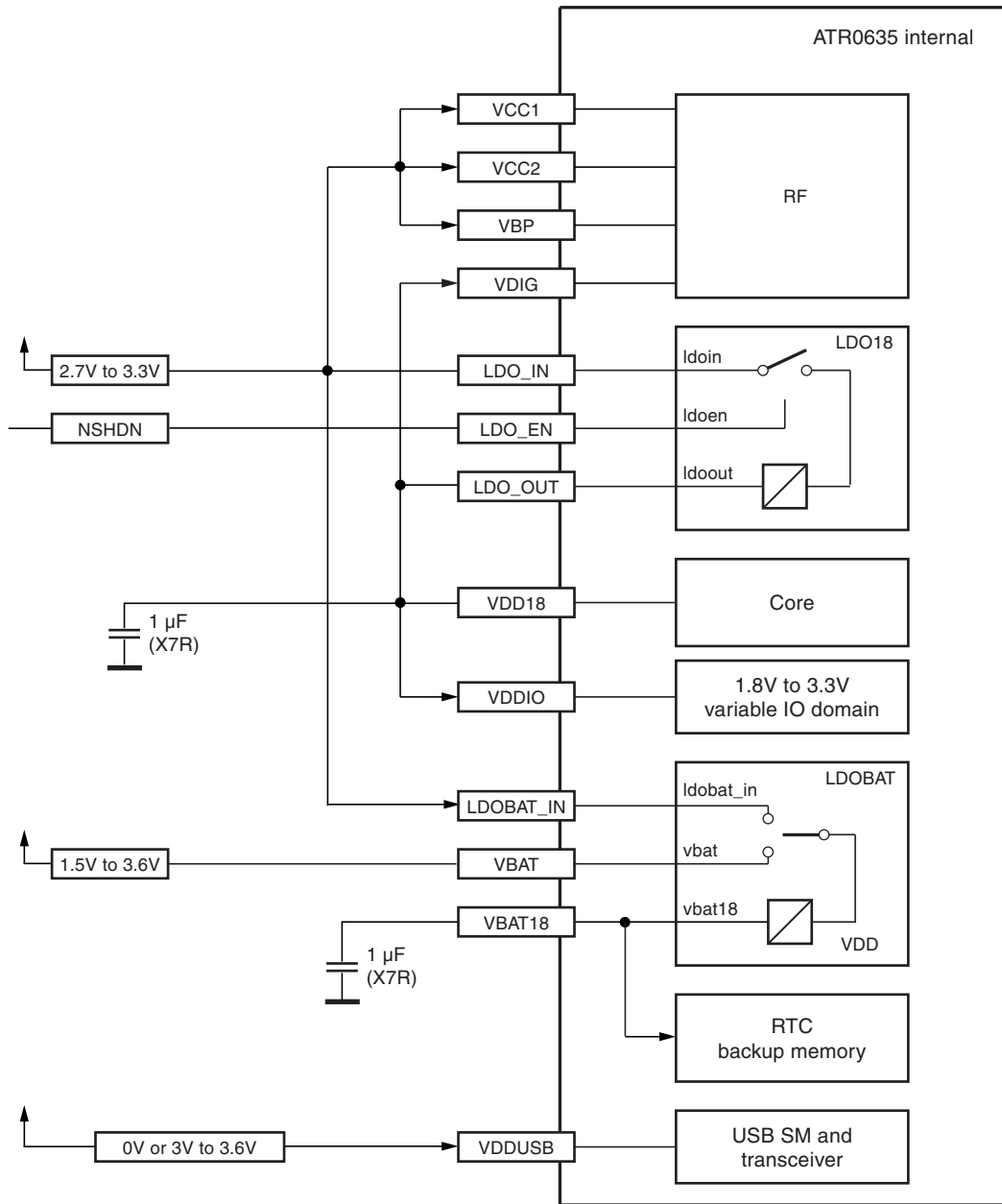

The USB Transceiver is disabled if VDD\_USB < 2.0V. In this case the pins USB\_DM and USB\_DP are connected to GND (internal pull-down resistors). The USB Transceiver is enabled if VDD\_USB within 3.0V and 3.6V.

Figure 4-3. Connecting Example: Separate Power Supplies for RF and Digital Part Using 1.8V from Host System

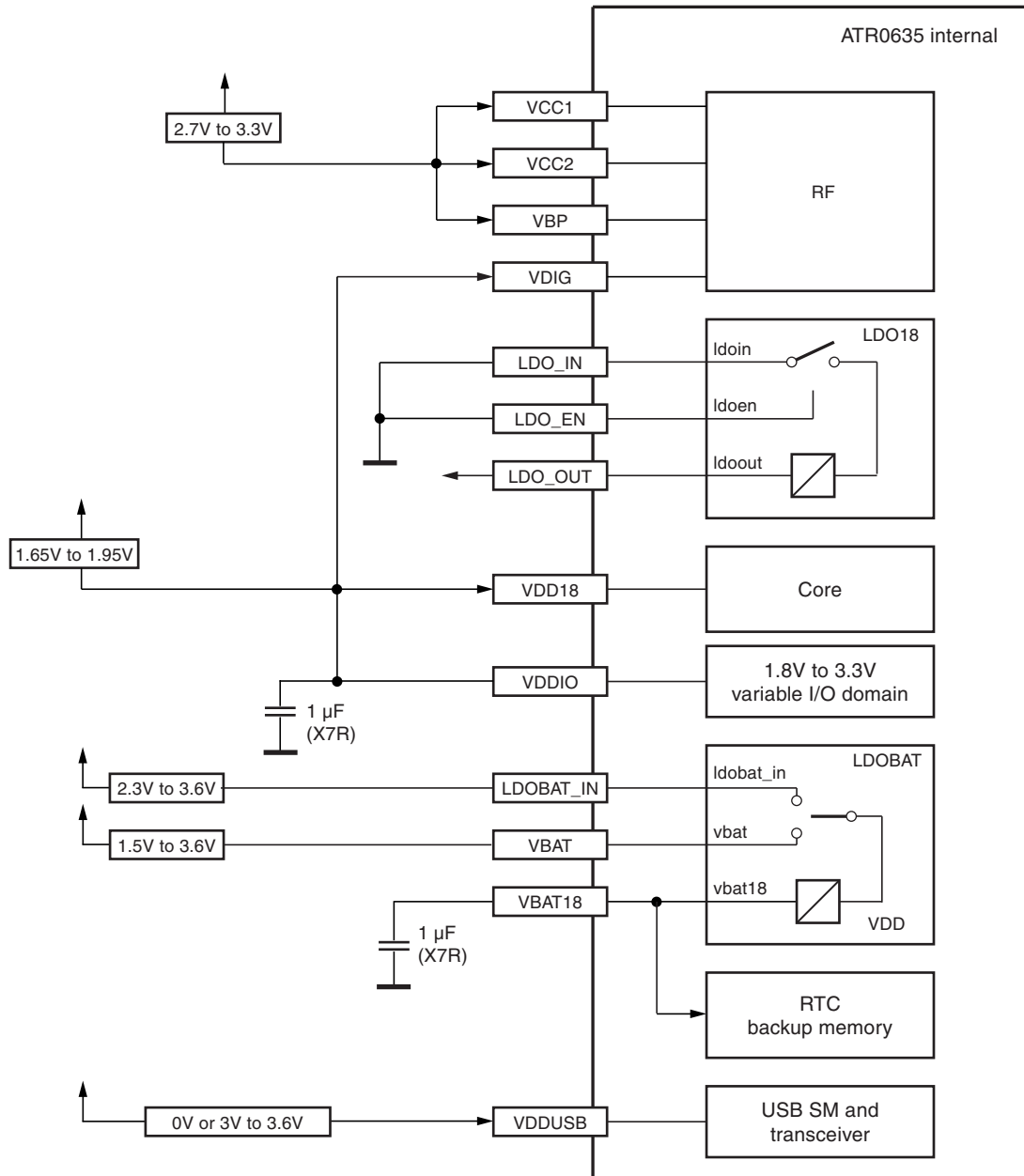

**Figure 4-4.** Connecting Example: Power Supply from USB Using the Internal LDOs

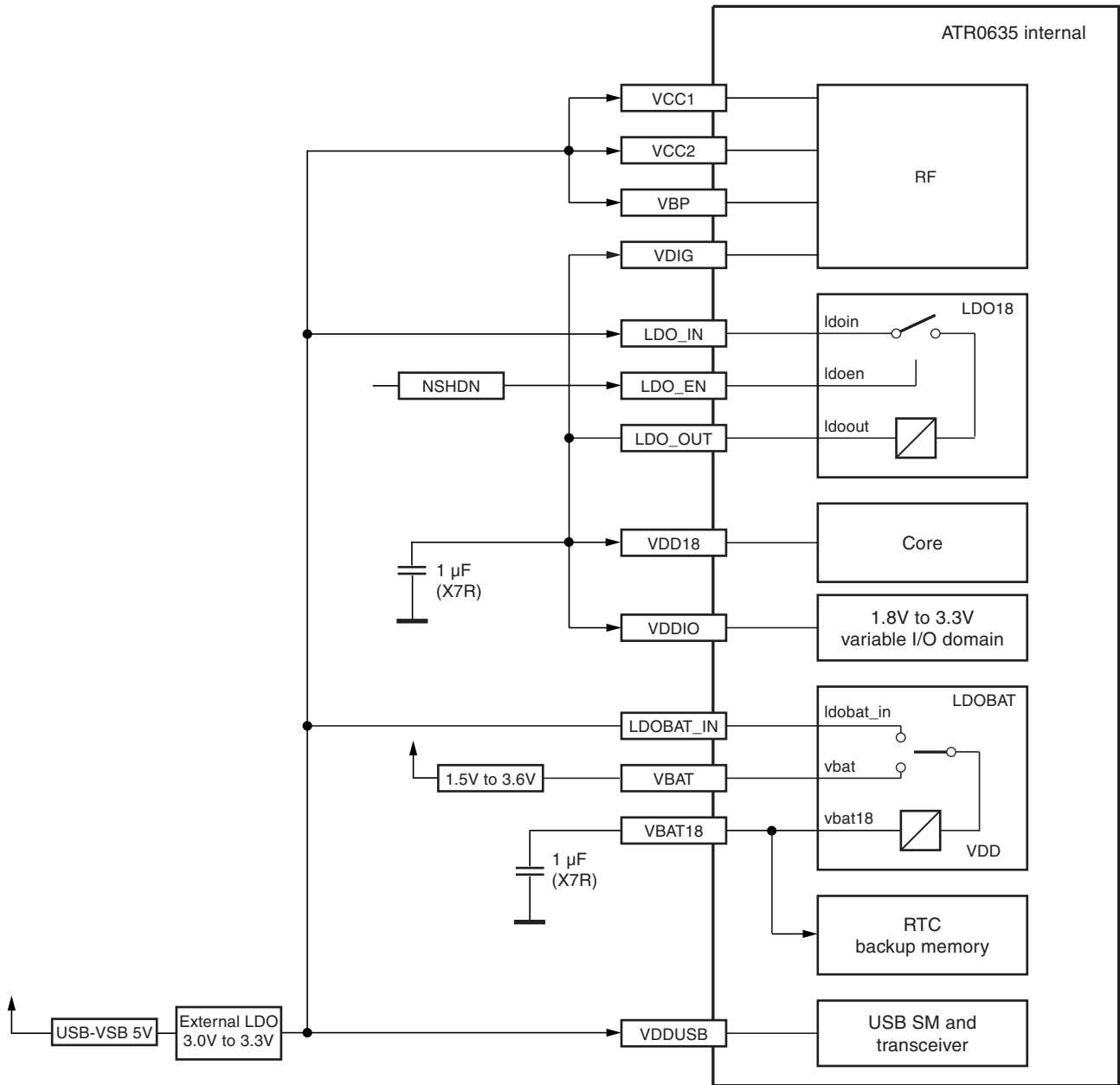



## 5. Crystals

The ATR0635 requires a GPS TCXO. The reference frequency is 23.104 MHz. By connecting an optional RTC crystal, different power modes are available. The reference frequency is 32.768 kHz.

### 5.1 GPS

**Figure 5-1.** Equivalent Application Examples Using a GPS TCXO (See [Table 5-1 on page 26](#))

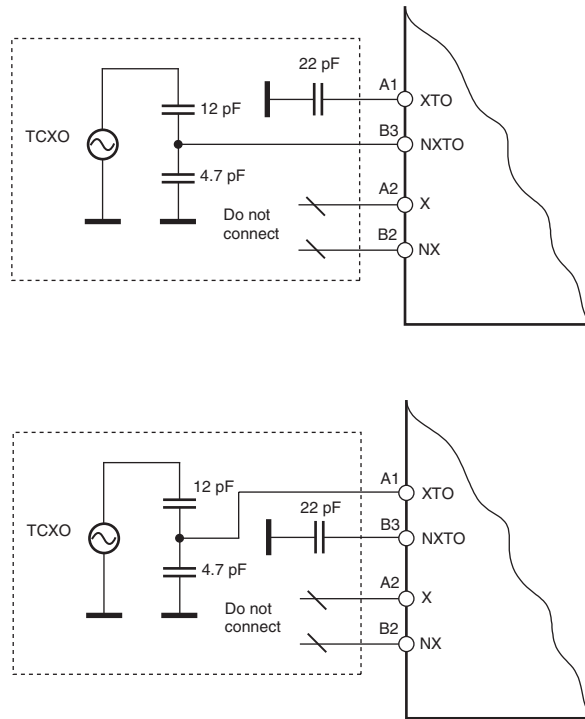

**Figure 5-2.** Application Example Using an External Reference Frequency and Balanced Inputs (See [Table 5-2 on page 26](#))

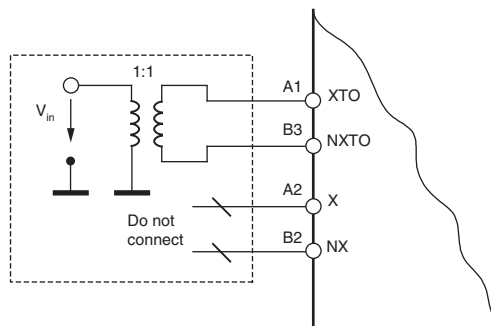

**Table 5-1.** Specification of GPS TCXOs Appropriate for the Application Example Shown in Figure 5-1 on page 25

Parameter	Comment	Min	Typ	Max	Units
<b>Frequency Characteristics</b>					
Nominal Frequency	Nominal frequency referenced to 25°C		23.104		MHz
Frequency deviation	Over operating temperature range			0.5	±ppm
	Including calibration, temperature, soldering and ageing effects			8	±ppm
Temperature range	Operating temperature range	-40.0		+85.0	°C
<b>Electrical</b>					
Output waveform	DC coupled clipped sine wave				
Output voltage (peak-to-peak)	Operating range	0.8		1.5	V
Output load capacitance	Tolerable load capacitance	10			pF

**Table 5-2.** Specification of an External Reference Signal for the Application Example Shown in Figure 5-2 on page 25

Parameter	Comment	Min	Typ	Max	Units
<b>Signal Characteristics</b>					
Nominal Frequency			23.104		MHz
Waveform	Sine wave or clipped sine wave				
Amplitude	Voltage peak-to-peak	0.6	0.9	1.2	V

## 5.2 RTC Oscillator

**Figure 5-3.** Crystal Connection

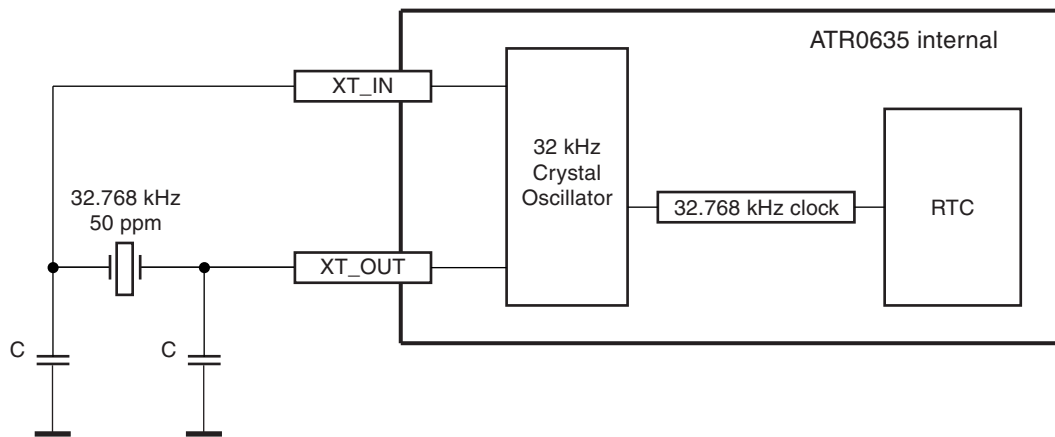

$C = 2 \times C_{load}$ ,  $C_{load}$  can be derived from the crystal datasheet. Maximum value for C is 25 pF.

## 6. Absolute Maximum Ratings

Stresses beyond those listed under “Absolute Maximum Ratings” may cause permanent damage to the device. This is a stress rating only and functional operation of the device at these or any other conditions beyond those indicated in the operational sections of this specification is not implied. Exposure to absolute maximum rating conditions for extended periods may affect device reliability.

Parameters	Pins	Symbol	Min	Max	Unit
Operating temperature		T <sub>op</sub>	-40	+85	°C
Storage temperature		T <sub>stg</sub>	-55	+125	°C
Analog supply voltage	VCC1, VCC2, VBP	V <sub>CC</sub>	-0.3	+3.7	V
Digital supply voltage RF	VDIG	V <sub>DIG</sub>	-0.3	+3.7	V
DC supply voltage core	VDD18	VDD18	-0.3	+1.95	V
DC supply voltage VDDIO domain	VDDIO	VDDIO	-0.3	+3.6	V
DC supply voltage USB	VDD_USB	VDD_USB	-0.3	+3.6	V
DC supply voltage LDO18	LDO_IN	LDO_IN	-0.3	+3.6	V
DC supply voltage LDOBAT	LDOBAT_IN	LDOBAT_IN	-0.3	+3.6	V
DC supply voltage VBAT	VBAT	VBAT	-0.3	+3.6	V
Digital input voltage	P0, P15, P30, XT_IN, TMS, TCK, TDI, NTRST, DBG_EN, LDO_EN, NRESET		-0.3	+1.95	V
Digital input voltage	USB_DM, USB_DP		-0.3	+3.6	V
Digital input voltage	P1, P2, P8, P9, P12 to P14, P16 to P27, P29, P31		-0.3	+5.0	V

Note: Minimum/maximum limits are at +25°C ambient temperature, unless otherwise specified.

## 7. Handling

The ATR0635 is an ESD-sensitive device. The current ESD values are to be defined. Observe proper precautions for handling.



## 8. Operating Range

Parameters	Pins	Symbol	Min	Typ	Max	Unit
Analog supply voltage RF	VCC1, VCC2, VBP	$V_{CC}$	2.70		3.30	V
Digital supply voltage RF	VDIG	$V_{DIG}$	1.65	1.8	1.95	V
Digital supply voltage core	VDD18	VDD18	1.65	1.8	1.95	V
Digital supply voltage VDDIO domain <sup>(1)</sup>	VDDIO	VDDIO	1.65	1.8/3.3	3.6	V
Digital supply voltage USB <sup>(2)</sup>	VDD_USB	VDD_USB	3.0	3.3	3.6	V
DC supply voltage LDO18	LDO_IN	LDO_IN	2.3		3.6	V
DC supply voltage LDOBAT	LDOBAT_IN	LDOBAT_IN	2.3		3.6	V
DC Supply voltage VBAT	VBAT	VBAT	1.5		3.6	V
Supply voltage difference ( $V_{\Delta} = V_{CC} - V_{DIG}$ )		$V_{\Delta}$		$\geq 0.80$		V
Temperature range		Temp	-40		+85	°C
Input frequency		$f_{RF}$		1575.42		MHz
Reference frequency GPS XTAL		$f_{TCXO}$		23.104		MHz
Reference frequency RTC		$f_{XTC}$		32.768		KHz

- Notes:
1. VDDIO is the supply voltage for the following GPIO-pins: P1, P2, P8, P12, P14, P16, P17, P18, P19, P20, P21, P23, P24, P25, P26, P27 and P29
  2. Values defined for operating USB Interface. Otherwise VDD\_USB may be connected to ground.

## 9. Electrical Characteristics

If no additional information is given in column Test Conditions, the values apply to temperature range from -40°C to +85°C.

No.	Parameters	Test Conditions	Pin	Symbol	Min	Typ	Max	Unit	Type*
<b>1</b>	<b>RF Front-end</b>								
1.1	Output frequency	$f_{TCXO} = 23.104$ MHz	C3	$f_{IF}$		96.764		MHz	A
1.2	Input impedance (balanced)	$f_{RF} = 1575.42$ MHz	D1, C1	$Z_{11}$		10 - j80		$\Omega$	C
1.3	Mixer conversion gain		C3	$G_{MIX}$		10		dB	C
1.4	Mixer noise figure (SSB)		C3	$NF_{MIX}$		6		dB	C
1.5	Maximum total gain	$V_{AGCO} = 2.2V$		$G_{max\_tot}$		90		dB	C
1.6	Total noise figure (SSB)			$NF_{tot}$		6.8		dB	C
<b>2</b>	<b>VGA/AGC</b>								
2.1	Minimum gain	$V_{AGCO} = 1.0V$		$G_{VGA,min}$		0		dB	C
2.2	Maximum gain	$V_{AGCO} = 2.2V$		$G_{VGA,max}$		70		dB	C
2.3	Control-voltage sensitivity	$V_{AGCO} = 2.2V$		$N_{VGA,min}$		6.6		dB/V	D
		$V_{AGCO} = 1.0V$		$N_{VGA,max}$		150		dB/V	D

\*) Type means: A = 100% tested, B = 100% correlation tested, C = Characterized on samples, D = Design parameter

- Notes:
1. The LDO18 is a built in low dropout voltage regulator, which can be used if the host system does not provide the core voltage VDD18.
  2. The LDOBAT is a built in low dropout voltage regulator, which provides the supply voltage VBAT18 for the RTC, backup SRAM, P9, P13, P22, P31, NSLEEP and NSHDN. The LDOBAT voltage regulator switches in battery mode if LDOBAT\_IN falls below 1.5V.
  3. Supply voltage VBAT18 for backup domain is generated internally by the LDOBAT.
  4. If no current is caused by outputs (pad output current as well as current across internal pull-up resistors)

## 9. Electrical Characteristics (Continued)

If no additional information is given in column Test Conditions, the values apply to temperature range from  $-40^{\circ}\text{C}$  to  $+85^{\circ}\text{C}$ .

No.	Parameters	Test Conditions	Pin	Symbol	Min	Typ	Max	Unit	Type*
2.4	AGC cut-off frequency	$C_{\text{ext}} = \text{open}$	A4	$f_{3\text{dB\_AGC}}$		250		kHz	D
2.5	AGC cut-off frequency	$C_{\text{ext}} = 100 \text{ pF}$	A4	$f_{3\text{dB\_AGC}}$		33		kHz	D
2.6	Gain-control output voltage, minimum	$V_{\text{CC}} = 2.7\text{V}$	A4	$V_{\text{AGCO}}$		0.9		V	B
2.7	Gain-control output voltage, maximum	$V_{\text{CC}} = 2.7\text{V}$	A4	$V_{\text{AGCO}}$		2.3		V	B
<b>3</b>	<b>PMSS</b>								
3.1	Voltage level power-on		F4, G4, H4	$V_{\text{PU,on}}$	1.3			V	C
3.2	Voltage level power-off		F4, G4, H4	$V_{\text{PU,off}}$			0.5	V	C
<b>4</b>	<b>LDO18<sup>(1)</sup></b>								
4.1	Output voltage		LDO_OUT		1.65	1.8	1.95	V	A
4.2	Output current		LDO_OUT				80	mA	A
4.3	Current consumption	After startup, no load, at room temperature					80	$\mu\text{A}$	A
4.4	Current consumption	Standby mode ( $\text{LDO\_EN} = 0$ ), at room temperature				1	5	$\mu\text{A}$	A
<b>5</b>	<b>LDOBAT<sup>(2)</sup></b>								
5.1	Output voltage <sup>(3)</sup>		VBAT18		1.65	1.8	1.95	V	A
5.2	Current consumption LDOBAT_IN <sup>(4)</sup>	After startup (sleep/backup mode), at room temperature					15	$\mu\text{A}$	A
5.3	Current consumption VBAT	After startup (backup mode and $\text{LDOBAT\_IN} = 0\text{V}$ ), at room temperature					10	$\mu\text{A}$	A
5.4	Current consumption	After startup (normal mode), at room temperature					1.5	mA	C
<b>6</b>	<b>Core</b>								
6.1	DC supply voltage VDD18			$V_{\text{O,18}}$	0		VDD18	V	D
6.2	DC supply voltage VDDIO			$V_{\text{O,IO}}$	0		VDDIO	V	D
6.3	Low-level input voltage VDD18 domain	$V_{\text{DD18}} = 1.65\text{V to } 1.95\text{V}$		$V_{\text{IL,18}}$	-0.3		$0.3 \times V_{\text{DD18}}$	V	C
6.4	High-level input voltage VDD18 domain	$V_{\text{DD18}} = 1.65\text{V to } 1.95\text{V}$		$V_{\text{IH,18}}$	$0.7 \times V_{\text{DD18}}$		$V_{\text{DD18}} + 0.3$	V	C

\*) Type means: A = 100% tested, B = 100% correlation tested, C = Characterized on samples, D = Design parameter

- Notes:
1. The LDO18 is a built in low dropout voltage regulator, which can be used if the host system does not provide the core voltage VDD18.
  2. The LDOBAT is a built in low dropout voltage regulator, which provides the supply voltage VBAT18 for the RTC, backup SRAM, P9, P13, P22, P31, NSLEEP and NSHDN. The LDOBAT voltage regulator switches in battery mode if LDOBAT\_IN falls below 1.5V.
  3. Supply voltage VBAT18 for backup domain is generated internally by the LDOBAT.
  4. If no current is caused by outputs (pad output current as well as current across internal pull-up resistors)

## 9. Electrical Characteristics (Continued)

If no additional information is given in column Test Conditions, the values apply to temperature range from  $-40^{\circ}\text{C}$  to  $+85^{\circ}\text{C}$ .

No.	Parameters	Test Conditions	Pin	Symbol	Min	Typ	Max	Unit	Type*
6.5	Schmitt trigger threshold rising	VDD18 = 1.65V to 1.95V	CLK23	$V_{th+,CLK23}$			$0.7 \times \text{VDD18}$	V	C
6.6	Schmitt trigger threshold falling	VDD18 = 1.65V to 1.95V	CLK23	$V_{th-,CLK23}$	$0.3 \times \text{VDD18}$			V	C
6.7	Schmitt trigger hysteresis	VDD18 = 1.65V to 1.95V	CLK23	$V_{hyst,CLK23}$	0.3		0.55	V	C
6.8	Schmitt trigger threshold rising	VDD18 = 1.65V to 1.95V	NRESET	$V_{th+,NRESET}$	0.8		1.3	V	C
6.9	Schmitt trigger threshold falling	VDD18 = 1.65V to 1.95V	NRESET	$V_{th-,NRESET}$	0.46		0.77	V	C
6.10	Low-level input voltage VDDIO domain	VDDIO = 1.65V to 3.6V		$V_{IL,IO}$	-0.3		+0.41	V	C
6.11	High-level input voltage VDDIO domain	VDDIO = 1.65V to 3.6V		$V_{IH,IO}$	1.46		5.0	V	C
6.12	Low-level input voltage VBAT18 domain	VBAT18 = 1.65V to 1.95V	A11, B10, C10, D10	$V_{IL,BAT}$	-0.3		+0.41	V	C
6.13	High-level input voltage VBAT18 domain	VBAT18 = 1.65V to 1.95V	A11, B10, C10, D10	$V_{IH,BAT}$	1.46		5.0	V	C
6.14	Low-level input voltage USB	VDD_USB = 3.0V to 3.6V	C9, D9	$V_{IL,USB}$	-0.3		+0.8	V	C
6.15	High-level input voltage USB	VDD_USB = 3.0V to 3.6V 39 $\Omega$ source resistance + 27 $\Omega$ external series resistor	C9, D9	$V_{IH,USB}$	2.0		4.6	V	C
6.16	Low-level output voltage VDD18 domain	$I_{OL} = 1.5 \text{ mA}$ , VDD18 = 1.65V		$V_{OL,18}$			0.4	V	A
6.17	High-level output voltage VDD18 domain	$I_{OH} = -1.5 \text{ mA}$ , VDD18 = 1.65V		$V_{OH,18}$	VDD18 - 0.45			V	A
6.18	Low-level output voltage VDDIO domain	$I_{OL} = 1.5 \text{ mA}$ , VDDIO = 3.0V		$V_{OL,IO}$			0.4	V	A
6.19	High-level output voltage VDDIO domain	$I_{OH} = -1.5 \text{ mA}$ , VDDIO = 3.0V		$V_{OH,IO}$	VDDIO - 0.5			V	A
6.20	Low-level output voltage VBAT18 domain	$I_{OL} = 1 \text{ mA}$	P9, P13, P22, P31	$V_{OL,BAT}$			0.4	V	A
6.21	High-level output voltage VBAT18 domain	$I_{OH} = -1 \text{ mA}$	P9, P13, P22, P31	$V_{OH,BAT}$	1.2			V	A
6.22	Low-level output voltage USB	$I_{OL} = 2.2 \text{ mA}$ , VDD_USB = 3.0V to 3.6V, 27 $\Omega$ external series resistor	DP, DM	$V_{OL,USB}$			0.3	V	A

\*) Type means: A = 100% tested, B = 100% correlation tested, C = Characterized on samples, D = Design parameter

- Notes:
1. The LDO18 is a built in low dropout voltage regulator, which can be used if the host system does not provide the core voltage VDD18.
  2. The LDOBAT is a built in low dropout voltage regulator, which provides the supply voltage VBAT18 for the RTC, backup SRAM, P9, P13, P22, P31, NSLEEP and NSHDN. The LDOBAT voltage regulator switches in battery mode if LDOBAT\_IN falls below 1.5V.
  3. Supply voltage VBAT18 for backup domain is generated internally by the LDOBAT.
  4. If no current is caused by outputs (pad output current as well as current across internal pull-up resistors)

## 9. Electrical Characteristics (Continued)

If no additional information is given in column Test Conditions, the values apply to temperature range from  $-40^{\circ}\text{C}$  to  $+85^{\circ}\text{C}$ .

No.	Parameters	Test Conditions	Pin	Symbol	Min	Typ	Max	Unit	Type*
6.23	High-level output voltage USB	$I_{OH} = 0.2\text{ mA}$ , VDD_USB = 3.0V to 3.6V, 27 $\Omega$ external series resistor	DP, DM	$V_{OH,USB}$	2.8			V	A
6.24	Input-leakage current (standard inputs and I/Os)	VDD18 = 1.95V $V_{IL} = 0\text{V}$		$I_{LEAK}$	-1		+1	$\mu\text{A}$	C
6.25	Input capacitance			$I_{CAP}$			10	pF	D
6.26	Input pull-up resistor NRESET	$-40^{\circ}\text{C}$ to $+85^{\circ}\text{C}$	A7	$R_{PU}$	0.7		1.8	k $\Omega$	C
6.27	Input pull-up resistors TCK, TDI, TMS	$-40^{\circ}\text{C}$ to $+85^{\circ}\text{C}$	G9, H10, G10	$R_{PU}$	7		18	k $\Omega$	C
6.28	Input pull-up resistors P9, P13, P22, P31	$-40^{\circ}\text{C}$ to $+85^{\circ}\text{C}$	A11, B10, C10, D10	$R_{PU}$	100		235	k $\Omega$	C
6.29	Input pull-down resistors DBG_EN, NTRST, RF_ON	$-40^{\circ}\text{C}$ to $+85^{\circ}\text{C}$	E8, H11	$R_{PD}$	7		18	k $\Omega$	C
6.30	Input pull-down resistors P0, P15, P30	$-40^{\circ}\text{C}$ to $+85^{\circ}\text{C}$	F10, C8, F11, G12	$R_{PD}$	100		235	k $\Omega$	C
6.31	Configurable input pull-up resistors P1, P2, P8, P12, P14, P16 to P21, P23 to P27, P29	VDDIO = 3.6V, $-40^{\circ}\text{C}$ to $+85^{\circ}\text{C}$ , $V_{PAD} = 3.6\text{V}$		$R_{CPU}$	50		160	k $\Omega$	C
6.32	Configurable input pull-down resistors P1, P2, P8, P12, P14, P16 to P21, P23 to P27, P29	VDDIO = 3.6V, $-40^{\circ}\text{C}$ to $+85^{\circ}\text{C}$ , $V_{PAD} = 3.6\text{V}$		$R_{CPD}$	40		160	k $\Omega$	C
6.33	Configurable input pull-up resistor USB_DP (idle state)	$-40^{\circ}\text{C}$ to $+85^{\circ}\text{C}$	C9	$R_{CPU}$	0.9		1.575	k $\Omega$	C
6.34	Configurable input pull-up resistor USP_DP (operation state)	$-40^{\circ}\text{C}$ to $+85^{\circ}\text{C}$	C9	$R_{CPU}$	1.425		3.09	k $\Omega$	C
6.35	Input pull-down resistors USB_DP, USB_DM	$-40^{\circ}\text{C}$ to $+85^{\circ}\text{C}$	C9, D9	$R_{PD}$	10		500	k $\Omega$	C

\*) Type means: A = 100% tested, B = 100% correlation tested, C = Characterized on samples, D = Design parameter

- Notes:
1. The LDO18 is a built in low dropout voltage regulator, which can be used if the host system does not provide the core voltage VDD18.
  2. The LDOBAT is a built in low dropout voltage regulator, which provides the supply voltage VBAT18 for the RTC, backup SRAM, P9, P13, P22, P31, NSLEEP and NSHDN. The LDOBAT voltage regulator switches in battery mode if LDOBAT\_IN falls below 1.5V.
  3. Supply voltage VBAT18 for backup domain is generated internally by the LDOBAT.
  4. If no current is caused by outputs (pad output current as well as current across internal pull-up resistors)

## 10. Power Consumption

**Table 10-1.** Power Consumption

Mode	Conditions	Typ.	Unit	Type*
Sleep	At 1.8V, no CLK23	0.065	mA	C
Shutdown	RTC, backup SRAM and LDOBAT	0.007		C
Normal	Satellite acquisition	40		C
	Normal tracking on 6 channels with 1 fix/s; each additional active tracking channel adds 0.5 mA	29		C
	All channels disabled	26		C

\*) Type means: A = 100% tested, B = 100% correlation tested, C = Characterized on samples, D = Design parameter



## 11. Ordering Information

Extended Type Number	Package	MPQ	Remarks
ATR0635-7KQY	BGA96	3000	7 mm × 10 mm, 0.8 mm pitch, Pb-free, RoHS-compliant
ATR0635-EK1	-	1	Evaluation kit/Road test kit
ATR0635-DK1	-	1	Design kit including design guide and PCB Gerber files

## 12. Package Information

Package: BGA96

Dimensions in mm

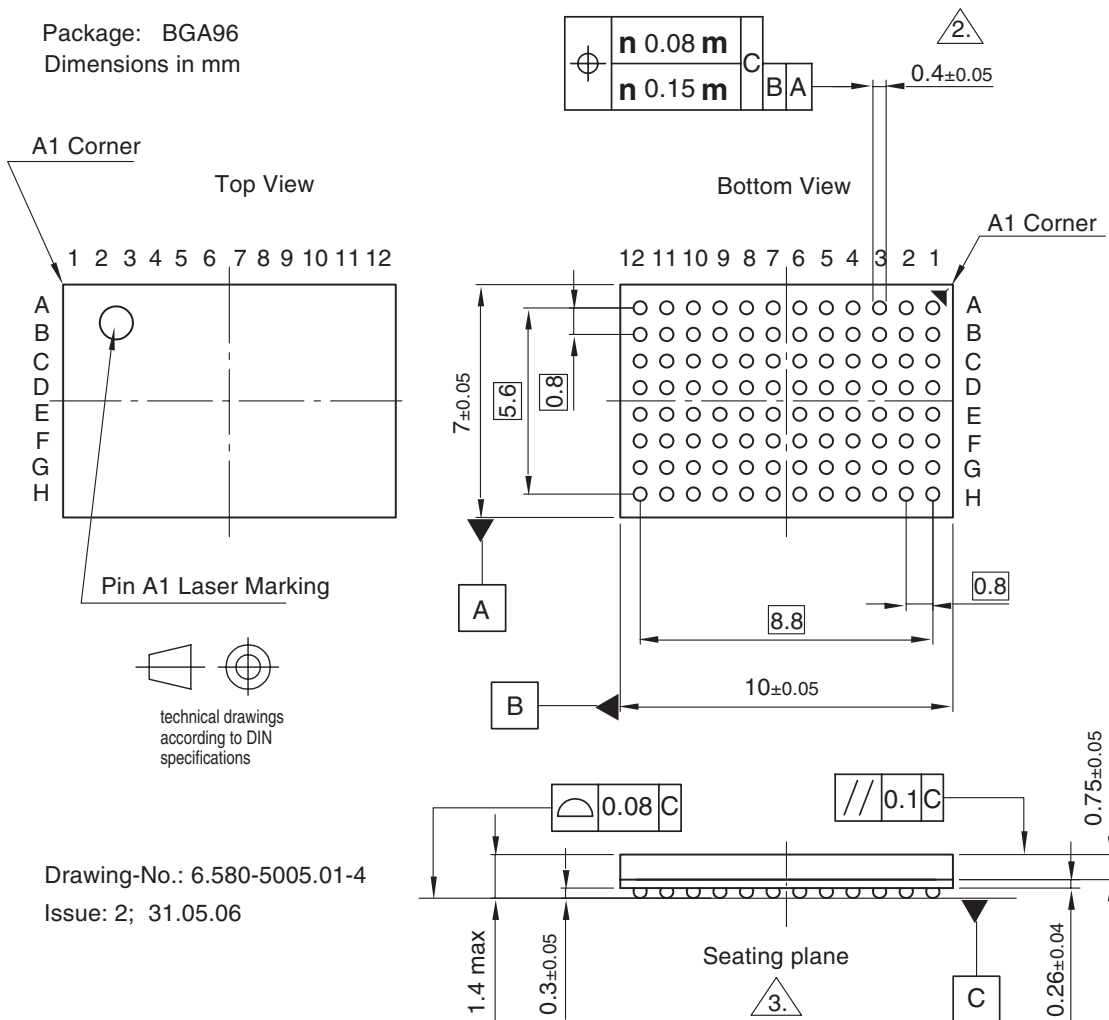

Drawing-No.: 6.580-5005.01-4

Issue: 2; 31.05.06

Note:

- All dimensions and tolerance conform to ASME Y 14.5M-1994
- Dimension is measured at the maximum solder ball diameter, parallel to primary datum C
- Primary datum C and seating plane are defined by the spherical crowns of the solder balls
- The surface finish of the package shall be EDM CHARMILLE #24 - #27
- Unless otherwise specified tolerance: Decimal ±0.05, Angular ±2°
- Raw ball diameter: 0.4 mm ref.

## 13. Revision History

Please note that the following page numbers referred to in this section refer to the specific revision mentioned, not to this document.

Revision No.	History
4928G-GPS-09/07	<ul style="list-style-type: none"><li>• Table 3-1 “ATR0635 Pinout” on page 6 changed</li></ul>
4928F-GPS-06/07	<ul style="list-style-type: none"><li>• Section 9 “Electrical Characteristics” numbers 6.31 and 6.32 on page 31 changed</li></ul>
4928E-GPS-03/07	<ul style="list-style-type: none"><li>• Table 3-2 “Signal Description” on pages 9 to 11 changed</li><li>• Table 10-1 “Power Consumption” on page 32 changed</li></ul>
4928D-GPS-01/07	<ul style="list-style-type: none"><li>• Put datasheet in a new template</li><li>• Table 3-11 “Serial I/O Default Setting if GPSPMODE Configuration is Deselected (GPSPMODE0 = 0)” on page 15 changed</li><li>• Section 9 “Electrical Characteristics” on pages 28 to 31 changed</li><li>• Section 10 “Power Consumption” on page 32 changed</li></ul>



## Headquarters

---

**Atmel Corporation**  
2325 Orchard Parkway  
San Jose, CA 95131  
USA  
Tel: 1(408) 441-0311  
Fax: 1(408) 487-2600

## International

---

**Atmel Asia**  
Room 1219  
Chinachem Golden Plaza  
77 Mody Road Tsimshatsui  
East Kowloon  
Hong Kong  
Tel: (852) 2721-9778  
Fax: (852) 2722-1369

**Atmel Europe**  
Le Krebs  
8, Rue Jean-Pierre Timbaud  
BP 309  
78054  
Saint-Quentin-en-Yvelines Cedex  
France  
Tel: (33) 1-30-60-70-00  
Fax: (33) 1-30-60-71-11

**Atmel Japan**  
9F, Tonetsu Shinkawa Bldg.  
1-24-8 Shinkawa  
Chuo-ku, Tokyo 104-0033  
Japan  
Tel: (81) 3-3523-3551  
Fax: (81) 3-3523-7581

## Product Contact

---

**Web Site**  
[www.atmel.com](http://www.atmel.com)

**Technical Support**  
[gps@atmel.com](mailto:gps@atmel.com)

**Sales Contact**  
[www.atmel.com/contacts](http://www.atmel.com/contacts)

**Literature Requests**  
[www.atmel.com/literature](http://www.atmel.com/literature)

---

**Disclaimer:** The information in this document is provided in connection with Atmel products. No license, express or implied, by estoppel or otherwise, to any intellectual property right is granted by this document or in connection with the sale of Atmel products. **EXCEPT AS SET FORTH IN ATMEL'S TERMS AND CONDITIONS OF SALE LOCATED ON ATMEL'S WEB SITE, ATMEL ASSUMES NO LIABILITY WHATSOEVER AND DISCLAIMS ANY EXPRESS, IMPLIED OR STATUTORY WARRANTY RELATING TO ITS PRODUCTS INCLUDING, BUT NOT LIMITED TO, THE IMPLIED WARRANTY OF MERCHANTABILITY, FITNESS FOR A PARTICULAR PURPOSE, OR NON-INFRINGEMENT. IN NO EVENT SHALL ATMEL BE LIABLE FOR ANY DIRECT, INDIRECT, CONSEQUENTIAL, PUNITIVE, SPECIAL OR INCIDENTAL DAMAGES (INCLUDING, WITHOUT LIMITATION, DAMAGES FOR LOSS OF PROFITS, BUSINESS INTERRUPTION, OR LOSS OF INFORMATION) ARISING OUT OF THE USE OR INABILITY TO USE THIS DOCUMENT, EVEN IF ATMEL HAS BEEN ADVISED OF THE POSSIBILITY OF SUCH DAMAGES.** Atmel makes no representations or warranties with respect to the accuracy or completeness of the contents of this document and reserves the right to make changes to specifications and product descriptions at any time without notice. Atmel does not make any commitment to update the information contained herein. Unless specifically provided otherwise, Atmel products are not suitable for, and shall not be used in, automotive applications. Atmel's products are not intended, authorized, or warranted for use as components in applications intended to support or sustain life.



© 2007, Atmel Corporation. All rights reserved. Atmel®, logo and combinations thereof, and others are registered trademarks or trademarks of Atmel Corporation or its subsidiaries. ARM®, ARM Powered® logo, ARM7TDMI® and others are the registered trademarks or trademarks of ARM Ltd. Other terms and product names may be trademarks of others.