

## Features

- 16-channel GPS Correlator
  - 8192 Search Bins with GPS Acquisition Accelerator
  - Accuracy: 2.5m CEP (Stand-Alone, S/A off)
  - Time to First Fix: 34s (Cold Start)
  - Acquisition Sensitivity: –142 dBm (Cold Start)
  - Tracking Sensitivity: –158 dBm
- Utilizes the ARM7TDMI® ARM® Thumb® Processor Core
  - High-performance 32-bit RISC Architecture
  - High-density 16-bit Instruction Set
  - EmbeddedICE™ (In-circuit Emulator)
- 128 Kbyte Internal RAM
- 384 Kbyte Internal ROM, Firmware Version V5.0
- Position TEchnology Provided by µ-blox
- 6-channel Peripheral Data Controller (PDC)
- 8-level Priority, Individually Maskable, Vectored Interrupt Controller
  - 2 External Interrupts
- 24 User-programmable I/O Lines
- 1 USB Device Port
  - Universal Serial Bus (USB) V2.0 Full-speed Device
  - Embedded USB V2.0 Full-speed Transceiver
  - Suspend/Resume Logic
  - Ping-pong Mode for Isochronous and Bulk Endpoints
- 2 USARTs
  - 2 Dedicated Peripheral Data Controller (PDC) Channels per USART
- Master/Slave SPI Interface
  - 2 Dedicated Peripheral Data Controller (PDC) Channels
  - 8-bit to 16-bit Programmable Data Length
  - 4 External Slave Chip Selects
- Programmable Watchdog Timer
- Advanced Power Management Controller (APMC)
  - Peripherals Can Be Deactivated Individually
  - Geared Master Clock to Reduce Power Consumption
  - Sleep State with Disabled Master Clock
  - Hibernate State with 32.768 kHz Master Clock
- Real Time Clock (RTC)
- 2.3V to 3.6V or 1.8V Core Supply Voltage
- Includes Power Supervisor
- 1.8V to 3.3V User-definable I/O Voltage for Several GPIOs with 5V Tolerance
- 4 Kbytes Battery Backup Memory
- 8 mm × 8 mm 56 Pin QFN56 Package
- RoHS-compliant, Green



## GPS Baseband Processor SuperSense

### ATR0625P



## 1. Description

The GPS baseband processor ATR0625P includes a 16-channel GPS correlator and is based on the ARM7TDMI processor core.

This processor has a high-performance 32-bit RISC architecture and very low power consumption. In addition, a large number of internally banked registers result in very fast exception handling, making the device ideal for real-time control applications. The ATR0625P has two USART and an USB device port. This port is compliant with the Universal Serial Bus (USB) V2.0 full-speed device specification.

The ATR0625P includes full GPS SuperSense<sup>®</sup> firmware, licensed from u-blox AG, which performs the basic GPS operation, including tracking, acquisition, navigation and position data output. For normal PVT (Position/Velocity/Time) applications, there is no need for off-chip Flash memory or ROM.

The firmware supports e.g. the NMEA<sup>®</sup> protocol (2.1 and 2.3), a binary protocol for PVT data, configuration and debugging, the RTCM protocol for DGPS, SBAS (WAAS, EGNOS and MSAS) and A-GPS (aiding). It is also possible to store the configuration settings in an optional external EEPROM.

The ATR0625P is manufactured using Atmel<sup>®</sup>'s high-density CMOS technology. By combining the ARM7TDMI microcontroller core with on-chip SRAM, 16-channel GPS correlator, and a wide range of peripheral functions on a monolithic chip, the ATR0625P provides a highly flexible and cost-effective solution for GPS applications.

Figure 1-1. ATR0625P Block Diagram

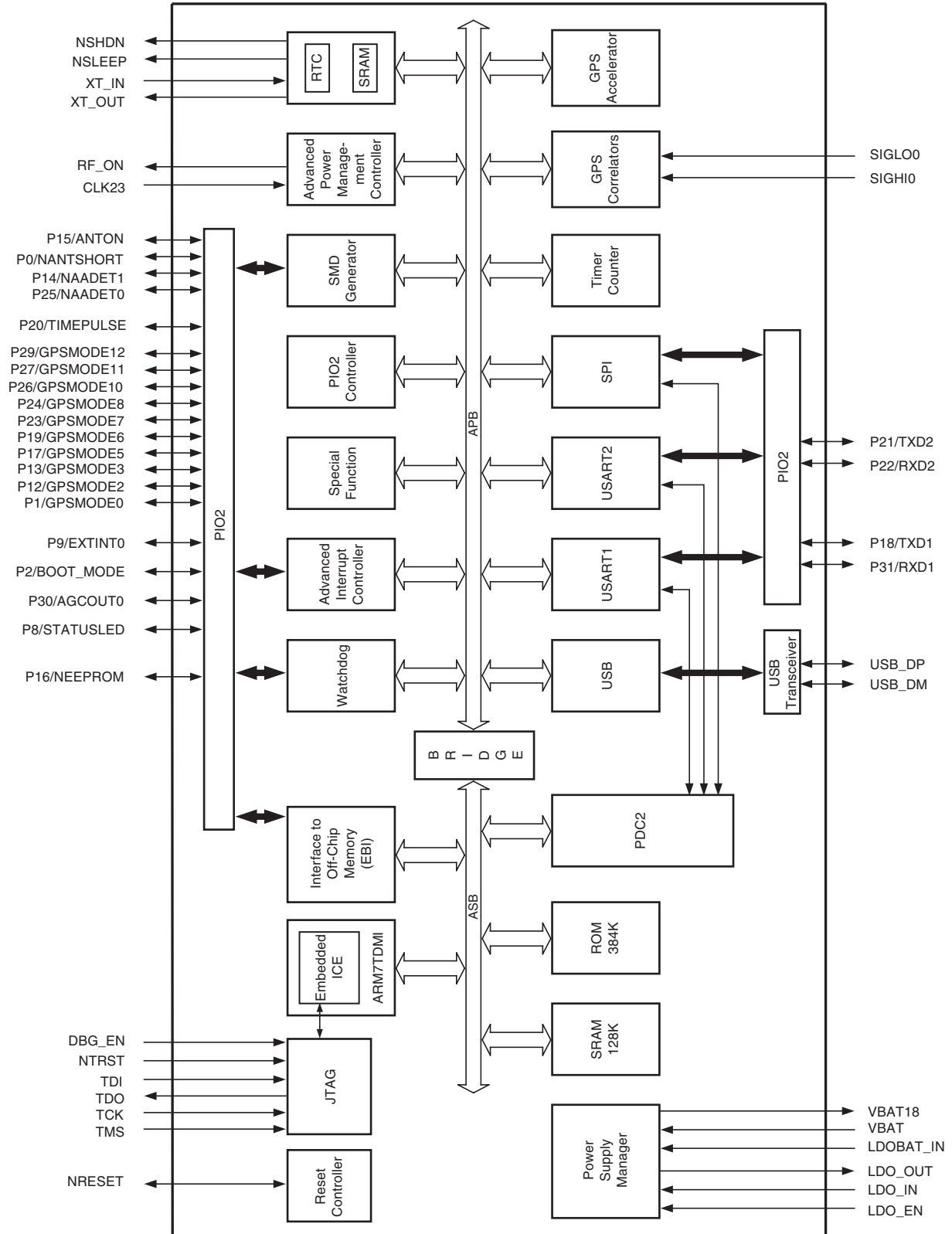

## 2. Architectural Overview

### 2.1 Description

The ATR0625P architecture consists of two main buses, the Advanced System Bus (ASB) and the Advanced Peripheral Bus (APB). The ASB is designed for maximum performance. It interfaces the processor with the on-chip 32-bit memories. The APB is designed for accesses to on-chip peripherals and is optimized for low power consumption. The AMBA™ Bridge provides an interface between the ASB and the APB.

An on-chip Peripheral Data Controller (PDC2) transfers data between the on-chip USARTs/SPI and the on-chip and off-chip memories without processor intervention. Most importantly, the PDC2 removes the processor interrupt handling overhead and significantly reduces the number of clock cycles required for a data transfer. It can transfer up to 64K contiguous bytes without reprogramming the starting address. As a result, the performance of the microcontroller is increased and the power consumption reduced.

The ATR0625P peripherals are designed to be easily programmable with a minimum number of instructions. Each peripheral has a 16 Kbyte address space allocated in the upper 3 Mbyte of the 4 Gbyte address space. (Except for the interrupt controller, which has 4 Kbyte address space.) The peripheral base address is the lowest address of its memory space. The peripheral register set is composed of control, mode, data, status, and interrupt registers.

To maximize the efficiency of bit manipulation, frequently written registers are mapped into three memory locations. The first address is used to set the individual register bits, the second resets the bits, and the third address reads the value stored in the register. A bit can be set or reset by writing a “1” to the corresponding position at the appropriate address. Writing a “0” has no effect. Individual bits can thus be modified without having to use costly read-modify-write and complex bit-manipulation instructions.

All of the external signals of the on-chip peripherals are under the control of the Parallel I/O (PIO2) Controller. The PIO2 Controller can be programmed to insert an input filter on each pin or generate an interrupt on a signal change. After reset, the user must carefully program the PIO2 Controller in order to define which peripheral signals are connected with off-chip logic.

The ARM7TDMI processor operates in little-endian mode on the ATR0625P GPS Baseband. The processor's internal architecture and the ARM and Thumb instruction sets are described in the ARM7TDMI datasheet.

The ARM standard In-Circuit Emulator (ICE) debug interface is supported via the JTAG/ICE port of the ATR0625P.

For features of the ROM firmware (SuperSense), refer to the software documentation available from u-blox AG, Switzerland.

## 3. Pin Configuration

### 3.1 Pinout

Figure 3-1. Pinout QFN56 (Top View)

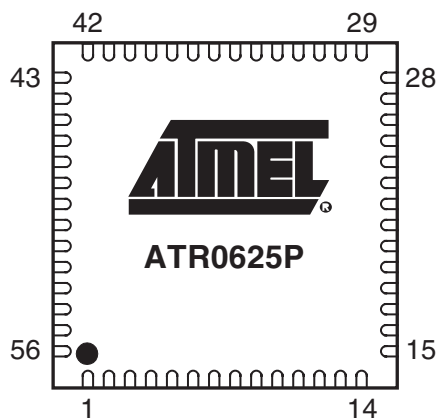

Table 3-1. ATR0625P Pinout

Pin Name	QFN56	Pin Type	Pull Resistor (Reset Value) <sup>(1)</sup>	Firmware Label	PIO Bank A	
					I	O
CLK23	37	OUT				
DBG_EN	8	IN	PD			
GND	<sup>(2)</sup>	IN				
LDOBAT_IN	21	IN				
LDO_EN	25	IN				
LDO_IN	20	IN				
LDO_OUT	19	OUT				
NRESET	41	I/O	Open Drain PU			
NSHDN	26	OUT				
NSLEEP	24	OUT				
NTRST	13	IN	PD			
P0	40	I/O	PD	NANTSHORT		
P1	47	I/O	Configurable (PD)	GPSMODE0		AGCOUT1
P2	46	I/O	Configurable (PD)	BOOT_MODE		"0"
P8	48	I/O	Configurable (PD)	STATUSLED		"0"
P9	29	I/O	PU to VBAT18	EXTINT0	EXTINT0	
P12	49	I/O	Configurable (PU)	GPSMODE2		NPCS2
P13	32	I/O	PU to VBAT18	GPSMODE3	EXTINT1	

- Notes:
1. PD = internal pull-down resistor, PU = internal pull-up resistor, OH = switched to Output High at reset
  2. Ground plane
  3. VBAT18 represent the internal power supply of the backup power domain, see section "Power Supply" on page 17.
  4. VDDIO is the supply voltage for the following GPIO-pins: P1, P2, P8, P12, P14, P16, P17, P18, P19, P20, P21, P23, P24, P25, P26, P27 and P29, see section "Power Supply" on page 17.
  5. VDD\_USB is the supply voltage for following the USB-pins: USB\_DM and USB\_DP, see section "Power Supply" on page 17. For operation of the USB interface, supply of 3.0V to 3.6V is required.
  6. This pin is not connected

**Table 3-1. ATR0625P Pinout (Continued)**

Pin Name	QFN56	Pin Type	Pull Resistor (Reset Value) <sup>(1)</sup>	Firmware Label	PIO Bank A	
					I	O
P14	1	I/O	Configurable (PD)	NAADET1		"0"
P15	17	I/O	PD	ANTON		
P16	6	I/O	Configurable (PU)	NEEPROM	SIGHI1	
P17	2	I/O	Configurable (PD)	GPSMODE5	SCK1	SCK1
P18	45	I/O	Configurable (PU)	TXD1		TXD1
P19	53	I/O	Configurable (PU)	GPSMODE6	SIGLO1	
P20	4	I/O	Configurable (PD)	TIMEPULSE	SCK2	SCK2
P21	52	I/O	Configurable (PU)	TXD2		TXD2
P22	30	I/O	PU to VBAT18	RXD2	RXD2	
P23	3	I/O	Configurable (PU)	GPSMODE7	SCK	SCK
P24	5	I/O	Configurable (PU)	GPSMODE8	MOSI	MOSI
P25	55	I/O	Configurable (PD)	NAADET0	MISO	MISO
P26	44	I/O	Configurable (PU)	GPSMODE10	NSS	NPCS0
P27	54	I/O	Configurable (PU)	GPSMODE11		NPCS1
P29	50	I/O	Configurable (PU)	GPSMODE12		NPCS3
P30	16	I/O	PD	AGCOUT0		AGCOUT0
P31	31	I/O	PU to VBAT18	RXD1	RXD1	
RF_ON	15	OUT	PD			
SIGHI0	38	IN				
SIGLO0	39	IN				
TCK	9	IN	PU			
TDI	10	IN	PU			
TDO	11	OUT				
TMS	12	IN	PU			
USB_DM	34	I/O				
USB_DP	35	I/O				
VBAT	22	IN				
VBAT18 <sup>(3)</sup>	23	OUT				
VDD18	7, 14	IN				
VDD18	18, 36	IN				
VDD18	51	IN				
VDDIO <sup>(4)</sup>	43, 56	IN				
VDD_USB <sup>(5)</sup>	33	IN				
XT_IN	28	IN				
XT_OUT	27	OUT				
NC <sup>(6)</sup>	42					

- Notes:
1. PD = internal pull-down resistor, PU = internal pull-up resistor, OH = switched to Output High at reset
  2. Ground plane
  3. VBAT18 represent the internal power supply of the backup power domain, see section ["Power Supply" on page 17](#).
  4. VDDIO is the supply voltage for the following GPIO-pins: P1, P2, P8, P12, P14, P16, P17, P18, P19, P20, P21, P23, P24, P25, P26, P27 and P29, see section ["Power Supply" on page 17](#).
  5. VDD\_USB is the supply voltage for following the USB-pins: USB\_DM and USB\_DP, see section ["Power Supply" on page 17](#). For operation of the USB interface, supply of 3.0V to 3.6V is required.
  6. This pin is not connected

## 3.2 Signal Description

**Table 3-2.** ATR0625P Signal Description

Module	Name	Function	Type	Active Level	Comment
EBI	BOOT_MODE	Boot Mode Input	Input	–	PIO-controlled after reset, internal pull-down resistor
USART	TXD1 to TXD2	Transmit Data Output	Output	–	PIO-controlled after reset
	RXD1 to RXD2	Receive Data Input	Input	–	PIO-controlled after reset
	SCK1 to SCK2	External Synchronous Serial Clock	I/O	–	PIO-controlled after reset
USB	USB_DP	USB Data (D+)	I/O	–	
	USB_DM	USB Data (D-)	I/O	–	
APMC	RF_ON		Output	–	Interface to ATR0601
AIC	EXTINT0-1	External Interrupt Request	Input	High/ Low/ Edge	PIO-controlled after reset
AGC	AGCOUT0-1	Automatic Gain Control	Output	–	Interface to ATR0601 PIO-controlled after reset
RTC	NSLEEP	Sleep Output	Output	Low	Interface to ATR0601
	NSHDN	Shutdown Output	Output	Low	Connect to pin LDO_EN
	XT_IN	Oscillator Input	Input	–	RTC oscillator
	XT_OUT	Oscillator Output	Output	–	RTC oscillator
SPI	SCK	SPI Clock	I/O	–	PIO-controlled after reset
	MOSI	Master Out Slave In	I/O	–	PIO-controlled after reset
	MISO	Master In Slave Out	I/O	–	PIO-controlled after reset
	NSS/NPCS0	Slave Select	I/O	Low	PIO-controlled after reset
	NPCS1 to NPCS3	Slave Select	Output	Low	PIO-controlled after reset
PIO	P0 to P31	Programmable I/O Port	I/O	–	Input after reset
GPS	SIGHI0	Digital IF	Input	–	Interface to ATR0601
	SIGLO0	Digital IF	Input	–	Interface to ATR0601
	SIGHI1	Digital IF	Input	–	PIO-controlled after reset
	SIGLO1	Digital IF	Input	–	PIO-controlled after reset
	TIMEPULSE	GPS synchronized time pulse	Output	–	PIO-controlled after reset
CONFIG	GPSMODE0-12	GPS Mode	Input	–	PIO-controlled after reset
	STATUSLED	Status LED	Output	–	PIO-controlled after reset
	NEEPROM	Enable EEPROM Support	Input	Low	PIO-controlled after reset
	ANTON	Active antenna power on Output	Output	–	PIO-controlled after reset
	NANTSHORT	Active antenna short circuit detection Input	Input	Low	PIO-controlled after reset
	NAADET0-1	Active antenna detection Input	Input	Low	PIO-controlled after reset

Note: 1. The USB transceiver is disabled if  $VDD\_USB < 2.0V$ . In this case the pins USB\_DM and USB\_DP are connected to GND (internal pull-down resistors). The USB transceiver is enabled if  $VDD\_USB$  is within 3.0V and 3.6V.

**Table 3-2. ATR0625P Signal Description (Continued)**

Module	Name	Function	Type	Active Level	Comment
JTAG/ICE	TMS	Test Mode Select	Input	–	Internal pull-up resistor
	TDI	Test Data In	Input	–	Internal pull-up resistor
	TDO	Test Data Out	Output	–	
	TCK	Test Clock	Input	–	Internal pull-up resistor
	NTRST	Test Reset Input	Input	Low	Internal pull-down resistor
	DBG_EN	Debug Enable	Input	High	Internal pull-down resistor
CLOCK	CLK23	Clock Input	Input	–	Interface to ATR0601, Schmitt trigger input
RESET	NRESET	Reset Input	I/O	Low	Open drain with internal pull-up resistor
POWER	VDD18		Power	–	Core voltage 1.8V
	VDDIO		Power	–	Variable IO voltage 1.65V to 3.6V
	VDD_USB		Power	–	USB voltage 0 to 2.0V or 3.0V to 3.6V <sup>(1)</sup>
	GND		Power	–	Ground
LDOBAT	LDOBAT_IN		Power	–	2.3V to 3.6V
	VBAT		Power	–	1.5V to 3.6V
	VBAT18		Out	–	1.8V backup voltage
LDO18	LDO_IN	LDO In	Power	–	2.3V to 3.6V
	LDO_OUT	LDO Out	Power	–	1.8V core voltage, max. 80 mA
	LDO_EN	LDO Enable	Input	–	

Note: 1. The USB transceiver is disabled if VDD\_USB < 2.0V. In this case the pins USB\_DM and USB\_DP are connected to GND (internal pull-down resistors). The USB transceiver is enabled if VDD\_USB is within 3.0V and 3.6V.



## 3.3 Setting GPSMODE0 to GPSMODE12

The start-up configuration of a ROM-based system without external non-volatile memory is defined by the status of the GPSMODE pins after system reset. Alternatively, the system can be configured through message commands passed through the serial interface after start-up. This configuration of the ATR0625P can be stored in an external non-volatile memory like EEPROM. *Default* designates settings used by ROM firmware if GPSMODE configuration is disabled (GPSMODE0 = 0).

**Table 3-3.** GPSMODE Functions

Pin	Function
GPSMODE0 (P1)	Enable configuration with GPSMODE pins
GPSMODE1 (P9)	This pin (EXTINT0) is used for <i>FixNow™</i> functionality and not used for GPSMODE configuration.
GPSMODE2 (P12)	GPS sensitivity settings
GPSMODE3 (P13)	
GPSMODE4 (P14)	This pin (NAADET1) is used as active antenna supervisor input and not used for GPSMODE configuration. This is the default selection if GPSMODE configuration is disabled.
GPSMODE5 (P17)	Serial I/O configuration
GPSMODE6 (P19)	
GPSMODE7 (P23)	USB Power Mode
GPSMODE8 (P24)	General I/O Configuration
GPSMODE9 (P25)	This pin (NAADET0) is used as active antenna supervisor input and not used for GPSMODE configuration.
GPSMODE10 (P26)	General I/O Configuration
GPSMODE11 (P27)	
GPSMODE12 (P29)	Serial I/O configuration

In the case that GPSMODE pins with internal pull-up or pull-down resistors are connected to GND/VDD18, additional current is drawn over these resistors. Especially GPSMODE3 can impact the back-up current.

### 3.3.1 Enable GPSMODE Pin Configuration

**Table 3-4.** Enable Configuration with GPSMODE Pins

GPSMODE0 (Reset = PD)	Description
0 <sup>(1)</sup>	Ignore all GPSMODE pins. The default settings as indicated below are used.
1	Use settings as specified with GPSMODE[2, 3, 5 to 8, 10 to 12]

Note: 1. Leave open

If the GPSMODE configuration is enabled (GPSMODE0 = 1) and the other GPSMODE pins are not connected externally, the reset default values of the internal pull-down and pull-up resistors will be used.

### 3.3.2 Sensitivity Settings

**Table 3-5.** GPS Sensitivity Settings

GPSMODE3 (Fixed PU)	GPSMODE2 (Reset = PU)	Description
0 <sup>(1)</sup>	0	Auto mode (Default ROM value)
0 <sup>(1)</sup>	1 <sup>(2)</sup>	Fast mode
1 <sup>(2)</sup>	0	Normal mode
1 <sup>(2)</sup>	1 <sup>(2)</sup>	High sensitivity

Notes: 1. Increased back-up current  
2. Leave open

For all GPS receivers the sensitivity depends on the integration time of the GPS signals. Therefore there is a trade-off between sensitivity and the time to detect the GPS signal (Time to first fix). The three modes, “Fast Acquisition”, “Normal” and “High Sensitivity”, have a fixed integration time. The “Normal” mode, recommended for the most applications, is a trade off between the sensitivity and TTFF. The “Fast Acquisition” mode is optimized for fast acquisition, at the cost of a lower sensitivity. The “High Sensitivity” mode is optimized for higher sensitivity, at the cost of longer TTFF. The “Auto” mode adjusts the integration time (sensitivity) automatically according to the measured signal levels. That means the receiver with this setting has a fast TTFF at strong signals, a high sensitivity to acquire weak signals but some times at medium signal level a higher TTFF as the “Normal” mode. These sensitivity settings affect only the startup performance not the tracking performance.

### 3.3.3 Serial I/O Configuration

The ATR0625P features a two-stage I/O message and protocol selection procedure for the two available serial ports. At the first stage, a certain protocol can be enabled or disabled for a given USART port or the USB port. Selectable protocols are RTCM, NMEA and UBX. At the second stage, messages can be enabled or disabled for each enabled protocol on each port. In all configurations discussed below, all protocols are enabled on all ports. But output messages are enabled in a way that ports appear to communicate at only one protocol. However, each port will accept any input message in any of the three implemented protocols.

**Table 3-6.** Serial I/O Configuration

GPSMODE12 (Reset = PU)	GPSMODE6 (Reset = PU)	GPSMODE5 (Reset = PD)	USART1/USB (Output Protocol/ Baud Rate (kBaud))	USART2 (Output Protocol/ Baud Rate (kBaud))	Messages <sup>(1)</sup>	Information Messages
0	0	0 <sup>(2)</sup>	UBX/57.6	NMEA/19.2	High	User, Notice, Warning, Error
0	0	1	UBX/38.4	NMEA/9.6	Medium	User, Notice, Warning, Error
0	1 <sup>(2)</sup>	0 <sup>(2)</sup>	UBX/19.2	NMEA/4.8	Low	User, Notice, Warning, Error
0	1 <sup>(2)</sup>	1	–/Auto	–/Auto	Off	None
1 <sup>(2)</sup>	0	0 <sup>(2)</sup>	NMEA/19.2	UBX/57.6	High	User, Notice, Warning, Error
1 <sup>(2)</sup>	0	1	NMEA/4.8	UBX/19.2	Low	User, Notice, Warning, Error
1 <sup>(2)</sup>	1 <sup>(2)</sup>	0 <sup>(2)</sup>	NMEA/9.6	UBX/38.4	Medium	User, Notice, Warning, Error
1 <sup>(2)</sup>	1 <sup>(2)</sup>	1	UBX/115.2	NMEA/19.2	Debug	All

Notes: 1. See [Table 3-7](#) to [Table 3-10](#) on page 11, the messages are described in the ANTARIS™ 4 protocol specification  
2. Leave open

Both USART ports and the USB port accept input messages in all three supported protocols (NMEA, RTCM and UBX) at the configured baud rate. Input messages of all three protocols can be arbitrarily mixed. Response to a query input message will always use the same protocol as the query input message. The USB port does only accept NMEA and UBX as input protocol by default. RTCM can be enabled via protocol messages on demand.

In Auto Mode, no output message is sent out by default, but all input messages are accepted at any supported baud rate. Again, USB is restricted to only NMEA and UBX protocols. Response to query input commands will be given the same protocol and baud rate as it was used for the query command. Using the respective configuration commands, periodic output messages can be enabled.

The following message settings are used in the tables below:

**Table 3-7.** Supported Messages at Setting *Low*

<b>NMEA Port</b>	Standard	GGA, RMC
	Proprietary	
<b>UBX Port</b>	NAV	SOL, SVINFO
	MON	EXCEPT

**Table 3-8.** Supported Messages at Setting *Medium*

<b>NMEA Port</b>	Standard	GGA, RMC, GSA, GSV, GLL, VTG, ZDA
	Proprietary	
<b>UBX Port</b>	NAV	SOL, SVINFO, POSECEF, POSLLH, STATUS, DOP, VELECEF, VELNED, TIMEGPS, TIMEUTC, CLOCK
	MON	EXCEPT

**Table 3-9.** Supported Messages at Setting *High*

<b>NMEA Port</b>	Standard	GGA, RMC, GSA, GSV, GLL, VTG, ZDA, GRS, GST
	Proprietary	PUBX00, PUBX03, PUBX04
<b>UBX Port</b>	NAV	SOL, SVINFO, POSECEF, POSLLH, STATUS, DOP, VELECEF, VELNED, TIMEGPS, TIMEUTC, CLOCK
	MON	SCHD, IO, IPC, EXCEPT

**Table 3-10.** Supported Messages at Setting *Debug* (Additional Undocumented Message May be Part of Output Data)

<b>NMEA Port</b>	Standard	GGA, RMC, GSA, GSV, GLL, VTG, ZDA, GRS, GST
	Proprietary	PUBX00, PUBX03, PUBX04
<b>UBX Port</b>	NAV	SOL, SVINFO, POSECEF, POSLLH, STATUS, DOP, VELECEF, VELNED, TIMEGPS, TIMEUTC, CLOCK
	MON	SCHD, IO, IPC, EXCEPT
	RXM	RAW (RAW message support requires an additional license)

The following settings apply if GPSMODE configuration is not enabled, that is, GPSMODE = 0 (ROM-Defaults):

**Table 3-11.** Serial I/O Default Setting if GPSMODE Configuration is Deselected (GPSMODE0 = 0)

	USB NMEA	USART1 NMEA	USART2 UBX
Baud Rate (kBaud)		57.6	57.6
Input Protocol	UBX, NMEA	UBX, NMEA, RTCM	UBX, NMEA, RTCM
Output Protocol	NMEA	NMEA	UBX
Messages	GGA, RMC, GSA, GSV	GGA, RMC, GSA, GSV	NAV: SOL, SVINFO MON: EXCEPT
Information Messages (UBX INF or NMEA TXT)	User, Notice, Warning, Error	User, Notice, Warning, Error	User, Notice, Warning, Error

### 3.3.4 USB Power Mode

For correct response to the USB host queries, the device has to know its power mode. This is configured via GPSMODE7. If set to *bus powered*, an upper current limit of 100 mA is reported to the USB host; that is, the device classifies itself as a “low-power bus-powered function” with no more than one USB power unit load.

**Table 3-12.** USB Power Modes

GPSMODE7 (Reset = PU)	Description
0	USB device is bus-powered (maximum current limit 100 mA)
1 <sup>(1)</sup>	USB device is self-powered (default ROM value)

Note: 1. Leave open

### 3.3.5 Active Antenna Supervisor

The two pins P0/NANTSHORT and P15/ANTON plus one pin of P25/NAADET0/MISO or P14/NAADET1 are always initialized as general purpose I/Os and used as follows:

- P15/ANTON is an output which can be used to switch on and off antenna power supply.
- Input P0/NANTSHORT will indicate an antenna short circuit, i.e. zero DC voltage at the antenna, to the firmware. If the antenna is switched off by output P15/ANTON, it is assumed that also input P0/NANTSHORT will signal zero DC voltage, i.e. switch to its active low state.
- Input P25/NAADET0/MISO or P14/NAADET1 will indicate a DC current into the antenna. In case of short circuit, both P0 and P25/P14 will be active, i.e. at low level. If the antenna is switched off by output P15/ANTON, it is assumed that also input P25/NAADET0/MISO will signal zero DC current, i.e. switch to its active low state. Which pin is used as NAADET (P14 or P25) depends on the settings of GPSMODE11 and GPSMODE10 (see [Table 3-14 on page 13](#)).

**Table 3-13.** Pin Usage of Active Antenna Supervisor

Pin	Usage	Meaning
P0/NANTSHORT	NANTSHORT	Active antenna short circuit detection High = No antenna DC short circuit present Low = Antenna DC short circuit present
P25/NAADDET0/ MISO or P14/NAADDET1	NAADDET	Active antenna detection input High = No active antenna present Low = Active antenna is present
P15/ANTON	ANTON	Active antenna power on output High = Power supply to active antenna is switched on Low = Power supply to active antenna is switched off

**Table 3-14.** Antenna Detection I/O Settings

GPSMODE11 (Reset = PU)	GPSMODE10 (Reset = PU)	GPSMODE8 (Reset = PU)	Location of NAADET	Comment
0	0	0	P25/NAADDET0/MISO	
0	0	1 <sup>(1)</sup>	P25/NAADDET0/MISO	
0	1 <sup>(1)</sup>	0	P14/NAADDET1	Reserved for further use. Do not use this setting.
0	1 <sup>(1)</sup>	1 <sup>(1)</sup>	P14/NAADDET1 (Default ROM value)	
1 <sup>(1)</sup>	0	0	P14/NAADDET1	Reserved for further use. Do not use this setting.
1 <sup>(1)</sup>	0	1 <sup>(1)</sup>	P14/NAADDET1	Reserved for further use. Do not use this setting.
1 <sup>(1)</sup>	1 <sup>(1)</sup>	0	P25/NAADDET0/MISO	
1 <sup>(1)</sup>	1 <sup>(1)</sup>	1 <sup>(1)</sup>	P25/NAADDET0/MISO	

Note: 1. Leave open

The Antenna Supervisor Software will be configured as follows:

1. Enable Control Signal
2. Enable Short Circuit Detection (power down antenna via ANTON if short is detected via NANTSHORT)
3. Enable Open Circuit Detection via NAADET

The antenna supervisor function may not be disabled by GPSMODE pin selection.

If the antenna supervisor function is not used, please leave open ANTON, NANTSHORT and NAADET.

### 3.4 External Connections for a Working GPS System

Figure 3-2. Example of an External Connection

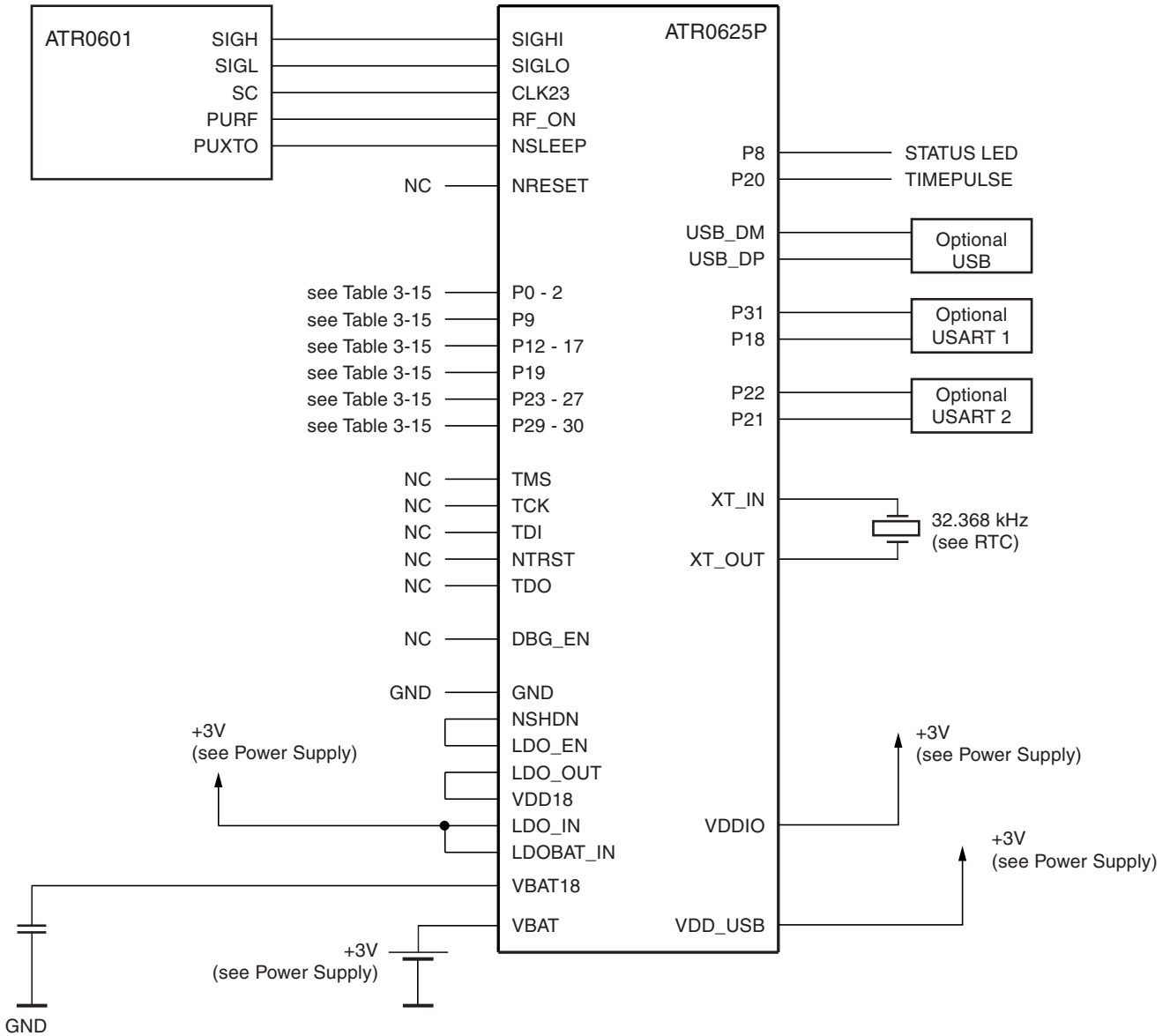

NC: Not connected

**Table 3-15.** Recommended Pin Connection

Pin Name	Recommended External Circuit
P0/NANTSHORT	Internal pull-down resistor, leave open if Antenna Supervision functionality is unused.
P1/GPSMODE0	Internal pull-down resistor, leave open, in order to disable the GPSMODE pin configuration feature. Connect to VDD18 to enable the GPSMODE pin configuration feature. Refer to GPSMODE definitions in section <a href="#">“Setting GPSMODE0 to GPSMODE12” on page 9.</a>
P2/BOOT_MODE	Internal pull-down resistor, leave open.
P8/STATUSLED	Output in default ROM firmware: leave open if not used
P9/EXTINT0	Internal pull-up resistor, leave open if unused.
P12/GPSMODE2/NPCS2	Internal pull-up resistor, can be left open if the GPSMODE feature is not used. Refer to GPSMODE definitions in section <a href="#">“Setting GPSMODE0 to GPSMODE12” on page 9.</a>
P13/GPSMODE3/ EXTINT1	Internal pull-up resistor, can be left open if the GPSMODE feature is not used. Refer to GPSMODE definitions in section <a href="#">“Setting GPSMODE0 to GPSMODE12” on page 9.</a>
P14/NAADET1	Internal pull-down resistor, leave open if Antenna Supervision functionality is unused.
P15/ANTON	Internal pull-down resistor, leave open if Antenna Supervision functionality is unused.
P16/NEEPROM	Internal pull-up resistor, leave open if no serial EEPROM is connected. Otherwise connect to GND.
P17/GPSMODE5/SCK1	Internal pull-down resistor, can be left open if the GPSMODE feature is not used. Refer to GPSMODE definitions in section <a href="#">“Setting GPSMODE0 to GPSMODE12” on page 9.</a>
P18/TXD1	Output in default ROM firmware: leave open if serial interface is not used.
P19/GPSMODE6/SIGLO1	Internal pull-up resistor, can be left open if the GPSMODE feature is not used. Refer to GPSMODE definitions in section <a href="#">“Setting GPSMODE0 to GPSMODE12” on page 9.</a>
P20/TIMEPULSE/SCK2	Output in default ROM firmware: leave open if timepulse feature is not used.
P21/TXD2	Output in default ROM firmware: leave open if serial interface not used.
P22/RXD2	Internal pull-up resistor, leave open if serial interface is not used.
P23/GPSMODE7/SCK	Internal pull-up resistor, can be left open if the GPSMODE feature is not used. Refer to GPSMODE definitions in section <a href="#">“Setting GPSMODE0 to GPSMODE12” on page 9.</a>
P24/GPSMODE8/MOSI	Internal pull-up resistor, can be left open if the GPSMODE feature is not used. Refer to GPSMODE definitions in section <a href="#">“Setting GPSMODE0 to GPSMODE12” on page 9.</a>
P25/NAADET0/MISO	Internal pull-down resistor, leave open if Antenna Supervision functionality is unused.
P26/GPSMODE10/NSS/ NPCS0	Internal pull-up resistor, can be left open if the GPSMODE feature is not used. Refer to GPSMODE definitions in section <a href="#">“Setting GPSMODE0 to GPSMODE12” on page 9.</a>
P27/GPSMODE11/NPCS1	Internal pull-up resistor, can be left open if the GPSMODE feature is not used. Refer to GPSMODE definitions in section <a href="#">“Setting GPSMODE0 to GPSMODE12” on page 9.</a>
P29/GPSMODE12/NPCS3	Internal pull-up resistor, can be left open if the GPSMODE feature is not used. Refer to GPSMODE definitions in section <a href="#">“Setting GPSMODE0 to GPSMODE12” on page 9.</a>
P30/AGCOUT0	Internal pull-down resistor, leave open.
P31/RXD1	Internal pull-up resistor, leave open if serial interface is not used.

### 3.4.1 Connecting an Optional Serial EEPROM

The ATR0625P offers the possibility to connect an external serial EEPROM. The internal ROM firmware supports to store the configuration of the ATR0625P in serial EEPROM. The pin P16/NEEPROM signals the firmware that a serial EEPROM is connected with the ATR0625P. The 32-bit RISC processor of the ATR0625P accesses the external memory with SPI (Serial Peripheral Interface). Atmel recommend to use 32 Kbit 1.8V serial EEPROM, e.g. the Atmel AT25320AY1-1.8. [Figure 3-3](#) shows an example of the serial EEPROM connection.

**Figure 3-3.** Example of a Serial EEPROM Connection

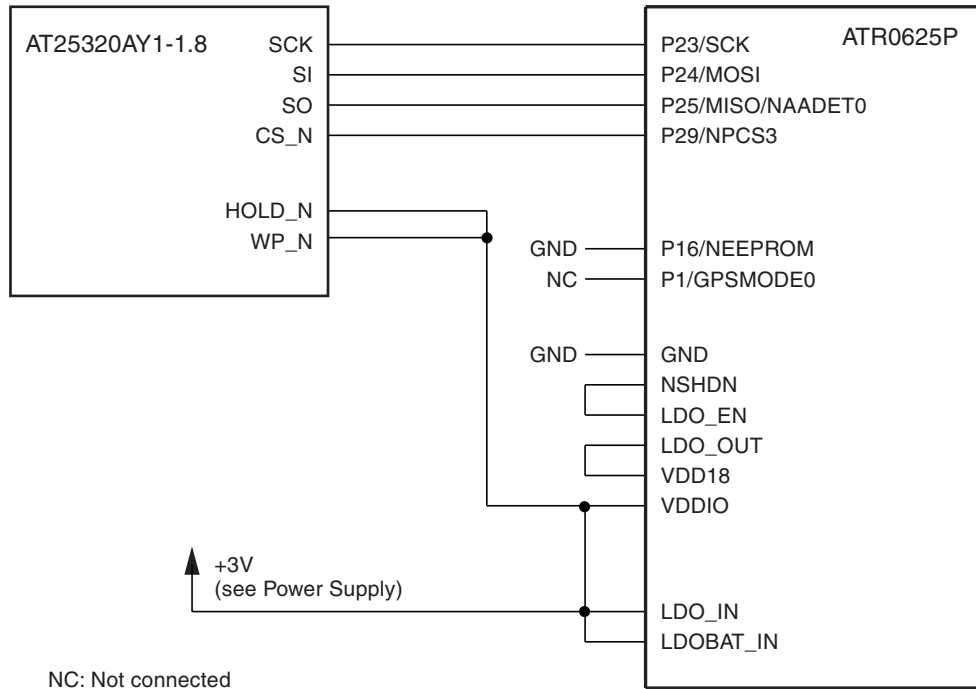

Note: The GPSMODE pin configuration feature can be disabled, because the configuration can be stored in the serial EEPROM. VDDIO is the supply voltage for the pins: P23, P24, P25 and P29.



## 4. Power Supply

The baseband IC is supplied with four distinct supply voltages:

- VDD18, the nominal 1.8V supply voltage for the core, the RF-I/O pins, the memory interface and the test pins and all GPIO-pins not mentioned in next item.
- VDDIO, the variable supply voltage within 1.8V to 3.6V for following GPIO-pins: P1, P2, P8, P12, P14, P16, P17, P18, P19, P20, P21, P23, P24, P25, P26, P27 and P29 In input mode, these pins are 5V input tolerant.
- VDD\_USB, the power supply of the USB pins: USB\_DM and USB\_DP.
- VBAT18 to supply the backup domain: RTC, backup SRAM and the pins NSLEEP, NSHDN, LDO\_EN, VBAT18, P9/EXTIN0, P13/EXTINT1, P22/RXD2 and P31/RXD1 and the 32kHz oscillator. In input mode, the four GPIO-pins are 5V input tolerant.

Figure 4-1, Figure 4-2, and Figure 4-3 show examples of the wiring of ATR0625P power supply.

**Figure 4-1.** External Wiring Example Using Internal LDOs and Backup Power Supply

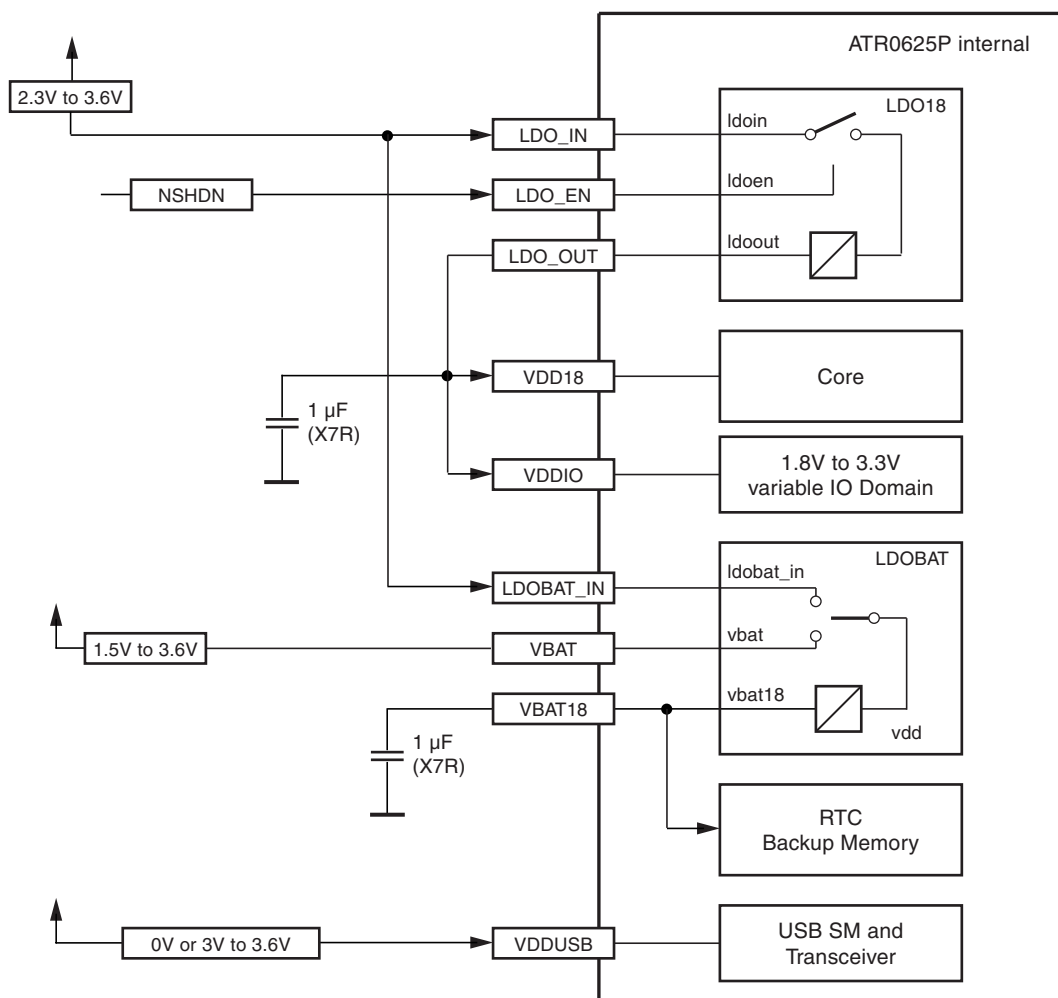

The baseband IC contains a built in low dropout voltage regulator LDO18. This regulator can be used if the host system does not provide the core voltage VDD18 of 1.8V nominal. In such case, LDO18 will provide a 1.8V supply voltage from any input voltage VDD between 2.3V and 3.6V. The LDO\_EN input can be used to shut down VDD18 if the system is in standby mode.

If the host system does however supply a 1.8V core voltage directly, this voltage has to be connected to the VDD18 supply pins of the baseband IC. LDO\_EN must be connected to GND. LDO\_IN can be connected to GND. LDO\_OUT must not be connected.

A second built in low dropout voltage regulator LDOBAT provides the supply voltage for the RTC and backup SRAM from any input voltage LDOBAT\_IN between 2.3V and 3.6V or from VBAT between 1.5V and 3.6V. The backup battery connected to VBAT is only discharged if the supply connected to LDOBAT\_IN is shut-down.

Only after VDD18 has been supplied to ATR0625P the RTC section will be initialized properly. If only VBAT is applied first, the current consumption of the RTC and backup SRAM is undetermined.

**Figure 4-2.** External Wiring Example Using 1.8V from Host System and Backup Power Supply

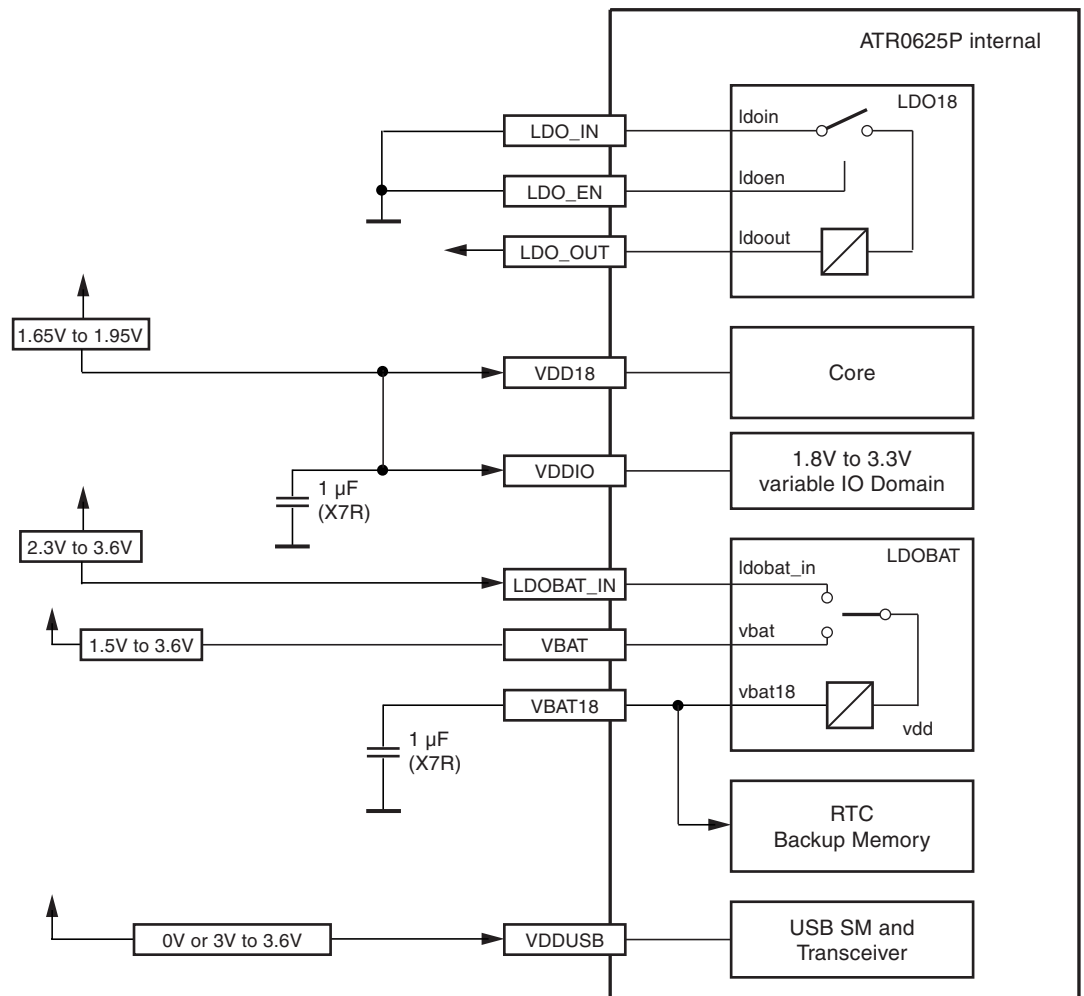

The USB Transceiver is disabled if VDD\_USB < 2.0V. In this case the pins USB\_DM and USB\_DP are connected to GND (internal pull-down resistors). The USB Transceiver is enabled if VDD\_USB within 3.0V and 3.6V.

**Figure 4-3.** External Wiring Example Using Internal LDOs, USB Supply Voltage and Backup Power Supply

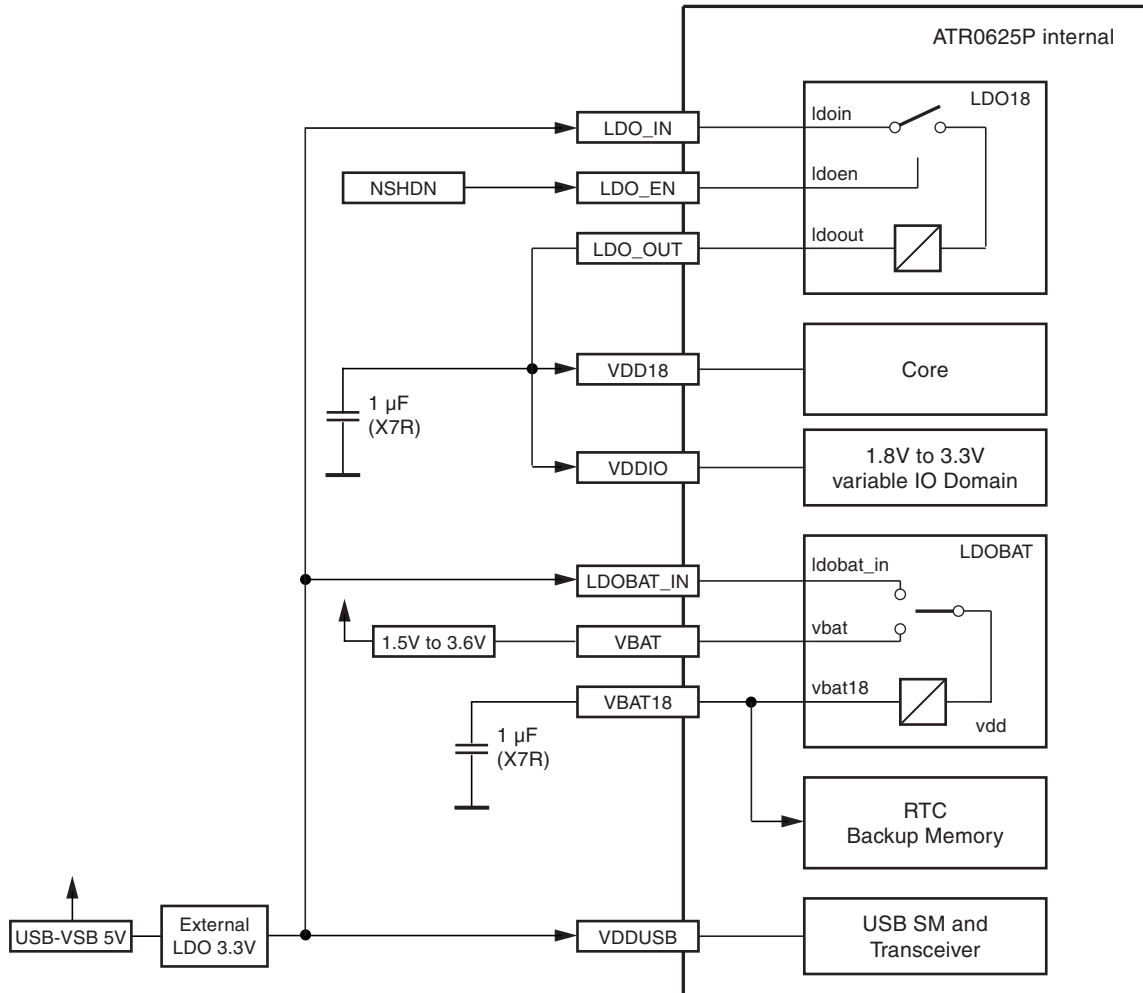

## 5. Oscillator

Figure 5-1. Crystal Connection

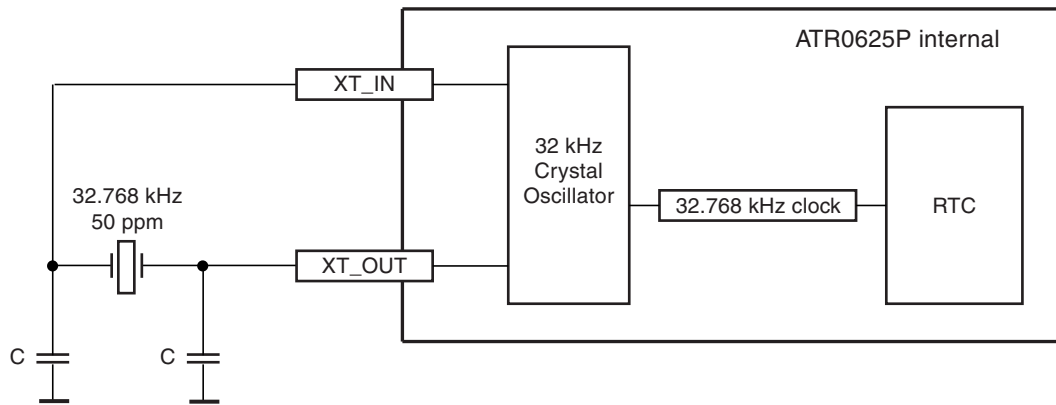

$C = 2 \times C_{load}$ ,  $C_{load}$  can be derived from the crystal datasheet. Maximum value for C is 25 pF.

## 6. Absolute Maximum Ratings

Stresses beyond those listed under “Absolute Maximum Ratings” may cause permanent damage to the device. This is a stress rating only and functional operation of the device at these or any other conditions beyond those indicated in the operational sections of this specification is not implied. Exposure to absolute maximum rating conditions for extended periods may affect device reliability.

Parameters	Pin	Symbol	Min.	Max.	Unit
Operating free air temperature range			-40	+85	°C
Storage temperature			-60	+150	°C
DC supply voltage	VDD18		-0.3	+1.95	V
	VDDIO		-0.3	+3.6	V
	VDD_USB		-0.3	+3.6	V
	LDO_IN		-0.3	+3.6	V
	LDOBAT_IN		-0.3	+3.6	V
	VBAT		-0.3	+3.6	V
DC input voltage	P0, P15, P30, SIGHI, SIGLO, CLK23, XT_IN, TMS, TCK, TDI, NTRST, DBG_EN, LDO_EN, NRESET		-0.3	+1.95	V
	USB_DM, USB_DP		-0.3	+3.6	V
	P1, P2, P8, P9, P12 to P14, P16 to P27, P29, P31		-0.3	+5.0	V

Note: Minimum/maximum limits are at +25°C ambient temperature, unless otherwise specified

## 7. Thermal Resistance

Parameters	Symbol	Value	Unit
Junction ambient, according to JEDEC51-5	$R_{thJA}$	24.2	K/W

## 8. Electrical Characteristics

If no additional information is given in column Test Conditions, the values apply to a temperature range from  $-40^{\circ}\text{C}$  to  $+85^{\circ}\text{C}$ .

No.	Parameters	Test Conditions	Pin	Symbol	Min.	Typ.	Max.	Unit	Type*
1.1	DC supply voltage core		VDD18	VDD18	1.65	1.8	1.95	V	D
1.2	DC supply voltage VDDIO domain <sup>(1)</sup>		VDDIO	VDDIO	1.65	1.8/3.3	3.6	V	D
1.3	DC supply voltage USB <sup>(2)</sup>		VDD_USB	VDDUSB	3.0	3.3	3.6	V	D
1.4	DC supply voltage backup domain <sup>(3)</sup>		VBAT18	VBAT18	1.65	1.8	1.95	V	D
1.5	DC output voltage VDD18			$V_{O,18}$	0		VDD18	V	D
1.6	DC output voltage VDDIO			$V_{O,IO}$	0		VDDIO	V	D
1.7	Low-level input voltage VDD18 domain	VDD18 = 1.65V to 1.95V		$V_{IL,18}$	-0.3		$0.3 \times \text{VDD18}$	V	C
1.8	High-level input voltage VDD18 domain	VDD18 = 1.65V to 1.95V		$V_{IH,18}$	$0.7 \times \text{VDD18}$		$\text{VDD18} + 0.3$	V	C
1.9	Schmitt trigger threshold rising	VDD18 = 1.65V to 1.95V	CLK23	$V_{th+,CLK23}$			$0.7 \times \text{VDD18}$	V	C
1.10	Schmitt trigger threshold falling	VDD18 = 1.65V to 1.95V	CLK23	$V_{th-,CLK23}$	$0.3 \times \text{VDD18}$			V	C
1.11	Schmitt trigger hysteresis	VDD18 = 1.65V to 1.95V	CLK23	$V_{hyst,CLK23}$	0.3		0.55	V	C
1.12	Schmitt trigger threshold rising	VDD18 = 1.65V to 1.95V	NRESET	$V_{th+,NRESET}$	0.8		1.3	V	C
1.13	Schmitt trigger threshold falling	VDD18 = 1.65V to 1.95V	NRESET	$V_{th-,NRESET}$	0.46		0.77	V	C
1.14	Low-level input voltage VDDIO domain	VDDIO = 1.65V to 3.6V		$V_{IL,IO}$	-0.3		+0.41	V	C
1.15	High-level input voltage VDDIO domain	VDDIO = 1.65V to 3.6V		$V_{IH,IO}$	1.46		5.0	V	C
1.16	Low-level input voltage VBAT18 domain	VBAT18 = 1.65V to 1.95V	P9, P13, P22, P31	$V_{IL,BAT}$	-0.3		+0.41	V	C
1.17	High-level input voltage VBAT18 domain	VBAT18 = 1.65V to 1.95V	P9, P13, P22, P31	$V_{IH,BAT}$	1.46		5.0	V	C
1.18	Low-level input voltage USB	VDD_USB = 3.0V to 3.6V, 39 $\Omega$ source resistance + 27 $\Omega$ external series resistor	DP, DM	$V_{IL,USB}$	-0.3		+0.8	V	C
1.19	High-level input voltage USB	VDD_USB = 3.0V to 3.6V	DP, DM	$V_{IH,USB}$	2.0		4.6	V	C
1.20	Low-level output voltage VDD18 domain	$I_{OL} = 1.5 \text{ mA}$ , VDD18 = 1.65V		$V_{OL,18}$			0.4	V	A
1.21	High-level output voltage VDD18 domain	$I_{OH} = -1.5 \text{ mA}$ , VDD18 = 1.65V		$V_{OH,18}$	VDD18 - 0.45			V	A
1.22	Low-level output voltage VDDIO domain	$I_{OL} = 1.5 \text{ mA}$ , VDDIO = 3.0V		$V_{OL,IO}$			0.4	V	A

- Notes:
1. VDDIO is the supply voltage for the following GPIO pins: P1, P2, P8, P12, P14, P16, P17, P18, P19, P20, P21, P23, P24, P25, P26, P27 and P29
  2. Values defined for operating the USB interface. Otherwise VDD\_USB may be connected to ground
  3. Supply voltage VBAT18 for backup domain is generated internally by the LDOBAT

## 8. Electrical Characteristics (Continued)

If no additional information is given in column Test Conditions, the values apply to a temperature range from  $-40^{\circ}\text{C}$  to  $+85^{\circ}\text{C}$ .

No.	Parameters	Test Conditions	Pin	Symbol	Min.	Typ.	Max.	Unit	Type*
1.23	High-level output voltage VDDIO domain	$I_{OH} = -1.5 \text{ mA}$ , VDDIO = 3.0V		$V_{OH,IO}$	VDDIO - 0.5			V	A
1.24	Low-level output voltage VBAT18 domain	$I_{OL} = 1 \text{ mA}$	P9, P13, P22, P31	$V_{OL,BAT}$			0.4	V	A
1.25	High-level output voltage VBAT18 domain	$I_{OH} = -1 \text{ mA}$	P9, P13, P22, P31	$V_{OH,BAT}$	1.2			V	A
1.26	Low-level output voltage USB	$I_{OL} = 2.2 \text{ mA}$ , VDD_USB = 3.0V to 3.6V, 27 $\Omega$ external series resistor	DP, DM	$V_{OL,USB}$			0.3	V	A
1.27	High-level output voltage USB	$I_{OH} = -0.2 \text{ mA}$ , VDD_USB = 3.0V to 3.6V, 27 $\Omega$ external series resistor	DP, DM	$V_{OH,USB}$	2.8			V	A
1.28	Input-leakage current (standard inputs and I/Os)	VDD18 = 1.95V $V_{IL} = 0V$		$I_{LEAK}$	-1		+1	$\mu\text{A}$	C
1.29	Input capacitance			$I_{CAP}$			10	pF	D
1.30	Input pull-up resistor		NRESET	$R_{PU}$	0.7		1.8	k $\Omega$	C
1.31	Input pull-up resistor		TCK, TDI, TMS	$R_{PU}$	7		18	k $\Omega$	C
1.32	Input pull-up resistor		P9, P13, P22, P31	$R_{PU}$	100		235	k $\Omega$	C
1.33	Input pull-down resistor		DBG_EN, NTRST,	$R_{PD}$	7		18	k $\Omega$	C
1.34	Input pull-down resistor		RF_ON, P0, P15, P30	$R_{PD}$	100		235	k $\Omega$	C
1.35	Configurable input pull-up resistor	VDDIO = 3.6V $V_{PAD} = 3.6V$	P1, P2, P8, P12, P14, P[16-21], P[23-27], P29	$R_{CPU}$	50		160	k $\Omega$	C
1.36	Configurable input pull-down resistor	VDDIO = 3.6V $V_{PAD} = 3.6V$	P1, P2, P8, P12, P14, P[16-21], P[23-27], P29	$R_{CPD}$	40		160	k $\Omega$	C
1.37	Configurable input pull-up resistor (Idle state)		USB_DP	$R_{CPU}$	0.9		1.575	k $\Omega$	C
1.38	Configurable input pull-up resistor (operation state)		USB_DP	$R_{CPU}$	1.425		3.09	k $\Omega$	C
1.39	Input pull-down resistor		USB_DP USB_DM	$R_{PD}$	10		500	k $\Omega$	C

- Notes:
1. VDDIO is the supply voltage for the following GPIO pins: P1, P2, P8, P12, P14, P16, P17, P18, P19, P20, P21, P23, P24, P25, P26, P27 and P29
  2. Values defined for operating the USB interface. Otherwise VDD\_USB may be connected to ground
  3. Supply voltage VBAT18 for backup domain is generated internally by the LDOBAT

## 9. Power Consumption

**Table 9-1.** Core Power Consumption

Mode	Conditions	Typ.	Unit	Type*
Sleep	At 1.8V, no CLK23	0.065	mA	C
Shutdown	RTC, backup SRAM and LDOBAT	0.007		C
Normal	Satellite acquisition	25		C
	Normal tracking on 6 channels with 1 fix/s; each additional active tracking channel adds 0.5 mA	14		C
	All channels disabled	11		C

\*) Type means: A = 100% tested, B = 100% correlation tested, C = Characterized on samples, D = Design parameter

## 10. ESD Sensitivity

The ATR0625P is an ESD sensitive device. The current ESD values are to be defined.

Observe precautions for handling.

**Table 10-1.** ESD- Sensitivity

Test Model	Max.	Unit
Human Body Model (HBM)	TBD	V

## 11. LDO18

The LDO18 is a built in low dropout voltage regulator which can be used if the host system does not provide the core voltage VDD18.

**Table 11-1.** Electrical Characteristics of LDO18

Parameter	Conditions	Min.	Typ.	Max.	Unit	Type*
Supply voltage LDO_IN		2.3		3.6	V	D
Output voltage (LDO_OUT)		1.65	1.8	1.95	V	A
Output current (LDO_OUT)				80	mA	A
Current consumption	After startup, no load, at room temperature			80	µA	A
Current consumption	Standby mode (LDO_EN = 0), at room temperature		1	5	µA	A

\*) Type means: A = 100% tested, B = 100% correlation tested, C = Characterized on samples, D = Design parameter

For well defined start-up of LDO18, LDO\_IN needs to be connected to LDOBAT\_IN.

## 12. LDOBAT and Backup Domain

The LDOBAT is a built in low dropout voltage regulator which provides the supply voltage VBAT18 for the RTC, backup SRAM, P9, P13, P22, P31, NSLEEP and NSHDN. The LDOBAT voltage regulator switches in battery mode if LDOBAT\_IN falls below 1.5V.

**Table 12-1.** Electrical Characteristics of LDOBAT

Parameter	Conditions	Min.	Typ.	Max.	Unit	Type*
Supply voltage LDOBAT_IN		2.3		3.6	V	D
Supply voltage VBAT		1.5		3.6	V	D
Output voltage (VBAT18)	If switch connects to LDOBAT_IN.	1.65	1.8	1.95	V	A
Output current (VBAT18)	No external load allowed			1.5	mA	D
Current consumption LDOBAT_IN <sup>(1)</sup>	After startup (sleep/backup mode), at room temperature			15	μA	A
Current consumption VBAT <sup>(1)</sup>	After startup (backup mode and LDOBAT_IN = 0V), at room temperature			10	μA	A
Current consumption	After startup (normal mode), at room temperature			1.5	mA	C

\*) Type means: A = 100% tested, B = 100% correlation tested, C = Characterized on samples, D = Design parameter

Note: 1. If no current is caused by outputs (pad output current as well as current across internal pull-up resistors)



### 13. Ordering Information

Extended Type Number	Package	MPQ	Remarks
ATR0625P-PYQW	QFN56	2000	8 mm × 8 mm, 0.50 mm pitch, RoHS-compliant, green
ATR0625-EK1	-	1	Evaluation kit/Road test kit
ATR0625-DK1	-	1	Development kit including example design information

### 14. Package QFN56

Package: QFN56 8 x 8

Exposed pad 6.5 x 6.5

Dimensions in mm

Not indicated tolerances ±0.05

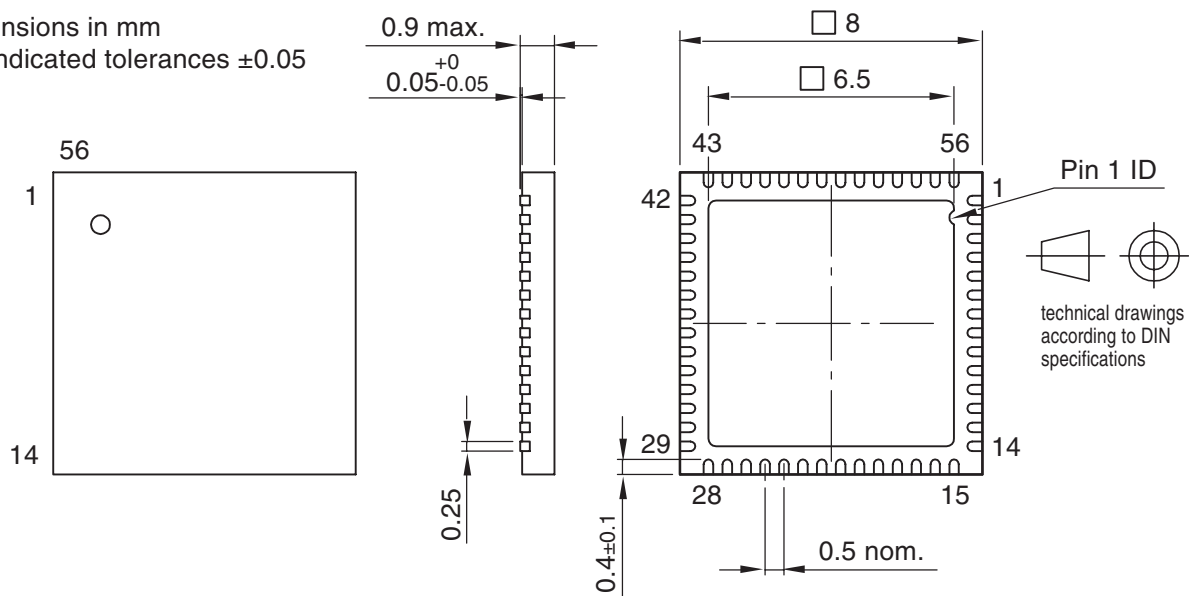

Drawing-No.: 6.543-5121.01-4

Issue: 1; 02.09.05

Moisture sensitivity level (MSL) = 3

## 15. Revision History

Please note that the following page numbers referred to in this section refer to the specific revision mentioned, not to this document.

Revision No.	History
4925F-GPS-09/07	<ul style="list-style-type: none"> <li>Table 3-1 "ATR0625P Pinout" on page 5 changed</li> </ul>
4925E-GPS-06/07	<ul style="list-style-type: none"> <li>Section 8 "Table Electrical Characteristics" numbers 1.35 and 1.36 on page 22 changed</li> </ul>
4925D-GPS-12/06	<ul style="list-style-type: none"> <li>All pages: Part number changed in ATR0625P</li> <li>Page 20: Abs. Max. Ratings table: some changes</li> <li>Page 21-22: El. Characteristics table: Type column added</li> <li>Page 23: Power Consumption table: Type column added</li> <li>Page 23: ESD Sensitivity table: Type column added</li> <li>Page 23: LDO18 table: Type column added</li> <li>Page 24: LDOBAT and Backup Domain table: Type column added</li> </ul>
4925C-GPS-10/06	<ul style="list-style-type: none"> <li>Section 7 "Thermal Resistance" on page 20 added</li> <li>Section 13 "Ordering Information" on page 25 changed</li> </ul>



## Headquarters

---

**Atmel Corporation**  
2325 Orchard Parkway  
San Jose, CA 95131  
USA  
Tel: 1(408) 441-0311  
Fax: 1(408) 487-2600

## International

---

**Atmel Asia**  
Room 1219  
Chinachem Golden Plaza  
77 Mody Road Tsimshatsui  
East Kowloon  
Hong Kong  
Tel: (852) 2721-9778  
Fax: (852) 2722-1369

**Atmel Europe**  
Le Krebs  
8, Rue Jean-Pierre Timbaud  
BP 309  
78054  
Saint-Quentin-en-Yvelines Cedex  
France  
Tel: (33) 1-30-60-70-00  
Fax: (33) 1-30-60-71-11

**Atmel Japan**  
9F, Tonetsu Shinkawa Bldg.  
1-24-8 Shinkawa  
Chuo-ku, Tokyo 104-0033  
Japan  
Tel: (81) 3-3523-3551  
Fax: (81) 3-3523-7581

## Product Contact

---

**Web Site**  
[www.atmel.com](http://www.atmel.com)

**Technical Support**  
[gps@atmel.com](mailto:gps@atmel.com)

**Sales Contact**  
[www.atmel.com/contacts](http://www.atmel.com/contacts)

**Literature Requests**  
[www.atmel.com/literature](http://www.atmel.com/literature)

---

**Disclaimer:** The information in this document is provided in connection with Atmel products. No license, express or implied, by estoppel or otherwise, to any intellectual property right is granted by this document or in connection with the sale of Atmel products. **EXCEPT AS SET FORTH IN ATMEL'S TERMS AND CONDITIONS OF SALE LOCATED ON ATMEL'S WEB SITE, ATMEL ASSUMES NO LIABILITY WHATSOEVER AND DISCLAIMS ANY EXPRESS, IMPLIED OR STATUTORY WARRANTY RELATING TO ITS PRODUCTS INCLUDING, BUT NOT LIMITED TO, THE IMPLIED WARRANTY OF MERCHANTABILITY, FITNESS FOR A PARTICULAR PURPOSE, OR NON-INFRINGEMENT. IN NO EVENT SHALL ATMEL BE LIABLE FOR ANY DIRECT, INDIRECT, CONSEQUENTIAL, PUNITIVE, SPECIAL OR INCIDENTAL DAMAGES (INCLUDING, WITHOUT LIMITATION, DAMAGES FOR LOSS OF PROFITS, BUSINESS INTERRUPTION, OR LOSS OF INFORMATION) ARISING OUT OF THE USE OR INABILITY TO USE THIS DOCUMENT, EVEN IF ATMEL HAS BEEN ADVISED OF THE POSSIBILITY OF SUCH DAMAGES.** Atmel makes no representations or warranties with respect to the accuracy or completeness of the contents of this document and reserves the right to make changes to specifications and product descriptions at any time without notice. Atmel does not make any commitment to update the information contained herein. Unless specifically provided otherwise, Atmel products are not suitable for, and shall not be used in, automotive applications. Atmel's products are not intended, authorized, or warranted for use as components in applications intended to support or sustain life.



© 2007 Atmel Corporation. All rights reserved. Atmel®, logo and combinations thereof, and others are registered trademarks or trademarks of Atmel Corporation or its subsidiaries. ARM®, ARM Powered® Logo, ARM7TDMI® and others are the registered trademarks or trademarks of ARM Ltd. Other terms and product names may be trademarks of others.