

128Kx24 SRAM 3.3 Volt FEATURES

- 128Kx24 bit CMOS Static
- Random Access Memory Array
 - Fast Access Times: 10, 12, and 15ns
 - Master Output Enable and Write Control
 - TTL Compatible Inputs and Outputs
 - Fully Static, No Clocks
- Surface Mount Package
 - 119 Lead BGA (JEDEC MO-163), No. 391
 - Small Footprint, 14mm x 22mm
 - Multiple Ground Pins for Maximum
- Noise Immunity
- Single +3.3V (±5%) Supply Operation
- DSP Memory Solution
- Motorola DSP5630xTM
- Analog Devices SHARCTM

DESCRIPTION

The EDI8L24129VxxBC is a 3.3V, three megabit SRAM constructed with three 128Kx8 die mounted on a multi-layer laminate substrate. With 10 to 15ns access times, x24 width and a 3.3V operating voltage, the EDI8L24129V is ideal for creating a single chip memory solution for the Motorola DSP5630x (Figure 3) or a two chip solution for the Analog Devices SHARCTM DSP (Figure 4).

The single or dual chip memory solutions offer improved system performance by reducing the length of board traces and the number of board connections compared to using multiple monolithic devices. For example, the capacitance load on the data lines for the BGA package is 58% less than a monolithic SOJ solution.

The JEDEC Standard 119 lead BGA provides a 44% space savings over using 128Kx8, 300mil wide SOJs and the BGA package has a maximum height of 100 mils compared to 148 mils for the SOJ packages. The BGA package also allows the use of the same manufacturing and inspection techniques as the Motorola DSP, which is also in a BGA package.

PIN CONFIGURATION

	1	2	3	4	5	6	7
A	NC	AO	A1	A2	A3	A4	NC
B	NC	A5	A6	E#	A7	A8	NC
C	I/012	NC	NC	NC	NC	NC	I/00
D	I/013	Vcc	GND	GND	GND	Vcc	I/01
E	I/014	GND	Vcc	GND	VCC	GND	I/02
F	I/015	Vcc	GND	GND	GND	Vcc	I/03
G	I/016	GND	Vcc	GND	Vcc	GND	I/04
H	I/017	Vcc	GND	GND	GND	Vcc	I/05
I	NC	GND	Vcc	GND	Vcc	GND	NC
J	I/018	Vcc	GND	GND	GND	Vcc	I/06
K	I/019	GND	Vcc	GND	Vcc	GND	I/07
L	I/020	Vcc	GND	GND	GND	Vcc	I/08
M	I/021	GND	Vcc	GND	Vcc	GND	I/09
N	I/022	Vcc	GND	GND	GND	Vcc	I/010
O	I/023	NC	NC	NC	NC	NC	I/011
P	NC	A9	A10	W#	A11	A12	NC
Q	NC	A13	A14	G#	A15	A16	NC

PIN NAMES

A0-A16	Address Inputs
E#	Chip Enable
W#	Master Write Enable
G#	Master Output Enable
DQ0-DQ23	Common Data Input/Output
Vcc	Power (3.3V±5%)
GND	Ground
NC	No Connection

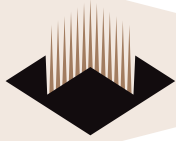

BLOCK DIAGRAM

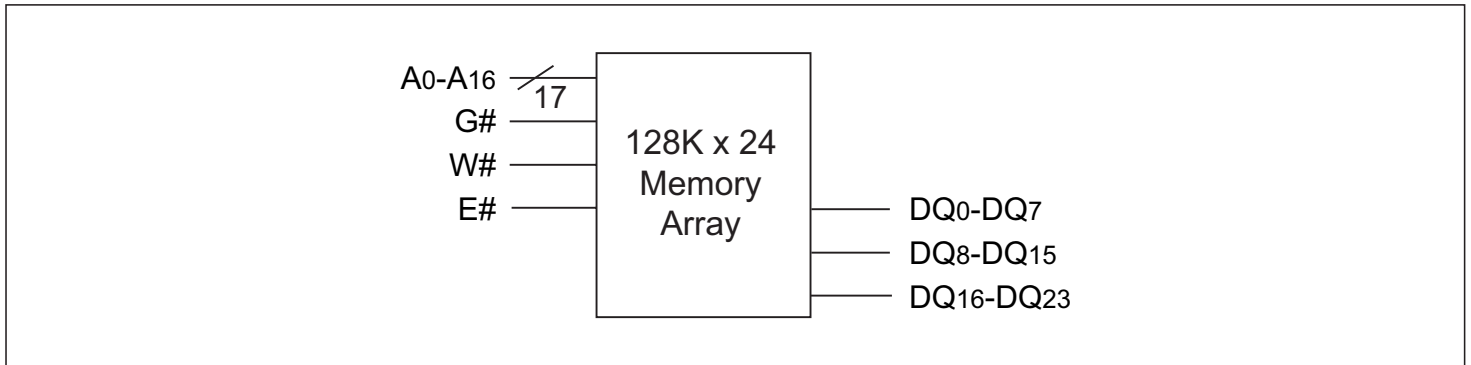

ABSOLUTE MAXIMUM RATINGS

Voltage on any pin relative to V _{ss}	-0.5V to 4.6V
Operating Temperature T _A (Ambient)	
Commercial	0°C to +70°C
Industrial	-40°C to +85°C
Storage Temperature	-55°C to +125°C
Power Dissipation	1.5 Watts
Output Current.	50 mA
Junction Temperature, T _J	175°C

RECOMMENDED OPERATING CONDITIONS

Parameter	Sym	Min	Typ	Max	Units
Supply Voltage	V _{cc}	3.135	3.3	3.465	V
Supply Voltage	V _{ss}	0	0	0	V
Input High Voltage	V _{IH}	2.2	-	V _{cc} +0.3	V
Input Low Voltage	V _{IL}	-0.3	-	0.8	V

* Stress greater than those listed under "Absolute Maximum Ratings" may cause permanent damage to the device. This is a stress rating only and functional operation of the device at these or any other conditions greater than those indicated in the operational sections of this specification is not implied. Exposure to absolute maximum rating conditions for extended periods may affect reliability.

TRUTH TABLE

G#	E#	W#	Mode	Output	Power
X	H	X	Standby	High Z	I _{cc2} , I _{cc3}
H	L	H	Output Deselect	High Z	I _{cc1}
L	L	H	Read	DOUT	I _{cc1}
X	L	L	Write	DIN	I _{cc1}

CAPACITANCE

f=1.0MHz, V_{IN}=V_{CC} or V_{SS}

Parameter	Sym	Max	Unit
Address Lines	CA	8	pF
Data Lines	CD/Q	10	pF
Write & Output Enable Lines	W#, G#	8	pF
Chip Enable Lines	E0#-E2#	8	pF

These parameters are sampled, not 100% tested.

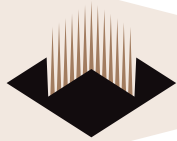

DC ELECTRICAL CHARACTERISTICS

Parameter	Sym	Conditions	Min	Max		Units
				10ns	12-15ns	
Operating Power Supply Current	I _{CC1}	W# = V _{IL} , I/I/O = 0mA, Min Cycle		420	360	mA
Standby (TTL) Supply Current	I _{CC2}	E# > V _{IH} , V _{IN} < V _{IL} or V _{IN} > V _{IH} , f=0MHz		90	75	mA
Full Standby CMOS Supply Current	I _{CC3}	E# > V _{CC} -0.2V V _{IN} > V _{CC} -0.2V or V _{IN} < 0.2V		10	10	mA
Input Leakage Current	I _{LI}	V _{IN} = 0V to V _{CC}		±10	±10	µA
Output Leakage Current	I _{LO}	V I/O = 0V to V _{CC}		±10	±10	µA
Output High Voltage	V _{OH}	I _{OH} = -4.0mA	2.4			V
Output Low Voltage	V _{OL}	I _{OL} = 8.0mA		0.4	0.4	V

AC TEST CIRCUIT

Figure 1

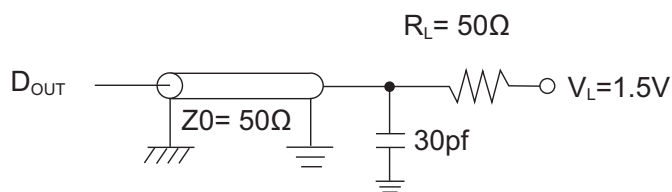

AC TEST CONDITIONS

Input Pulse Levels	V _{SS} to 3.0V
Input Rise and Fall Times	5ns
Input and Output Timing Levels	1.5V
Output Load	Figure 1

(NOTE: For t_{EH0Z}, t_{GH0Z} and t_{WL0Z}, Figure 2)

Figure 2

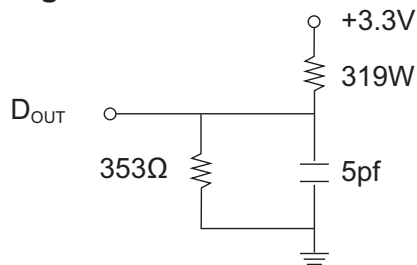

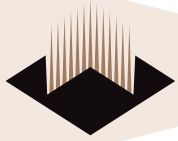

AC CHARACTERISTICS – READ CYCLE

Parameter	Symbol		10ns		12ns		15ns		Units
	JEDEC	Alt.	Min	Max	Min	Max	Min	Max	
Read Cycle Time	t _{AVAV}	t _{RC}	10		12		15		ns
Address Access Time	t _{AVQV}	t _{AA}		10		12		15	ns
Chip Enable Access Time	t _{ELQV}	t _{ACS}		10		12		15	ns
Chip Enable to Output in Low Z (1)	t _{ELQX}	t _{CLZ}	3		3		3		ns
Chip Disable to Output in High Z (1)	t _{EHQZ}	t _{CHZ}		5		6		7	ns
Output Hold from Address Change	t _{AVQX}	t _{OH}	3		3		3		ns
Output Enable to Output Valid	t _{GLQV}	t _{OE}		5		6		7	ns
Output Enable to Output in Low Z (1)	t _{GLQX}	t _{OLZ}	0		0		0		ns
Output Disable to Output in High Z(1)	t _{GHQZ}	t _{OHZ}		5		6		7	ns

Note 1: Parameter guaranteed, but not tested.

READ CYCLE – W# HIGH, G#, E# LOW

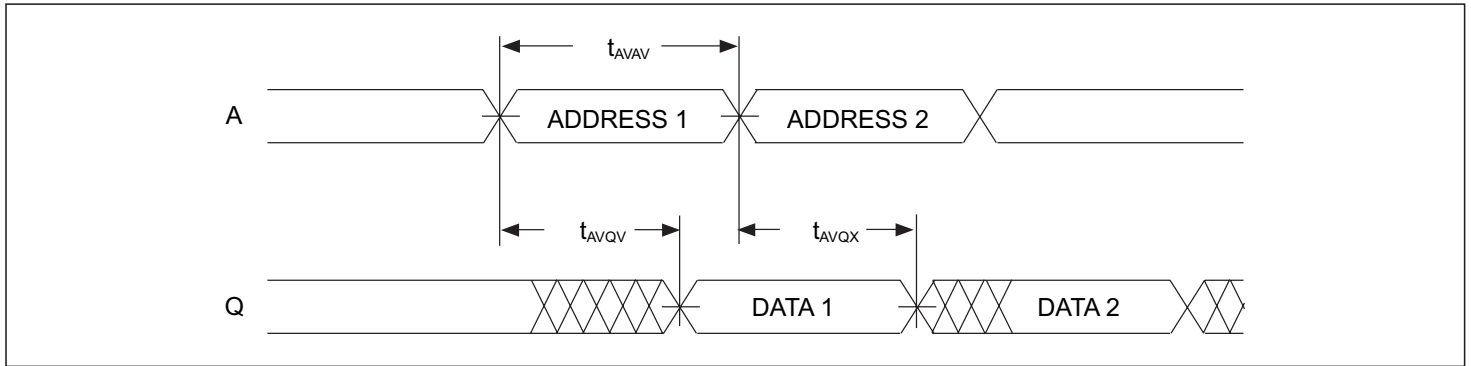

READ CYCLE 2 – W# HIGH

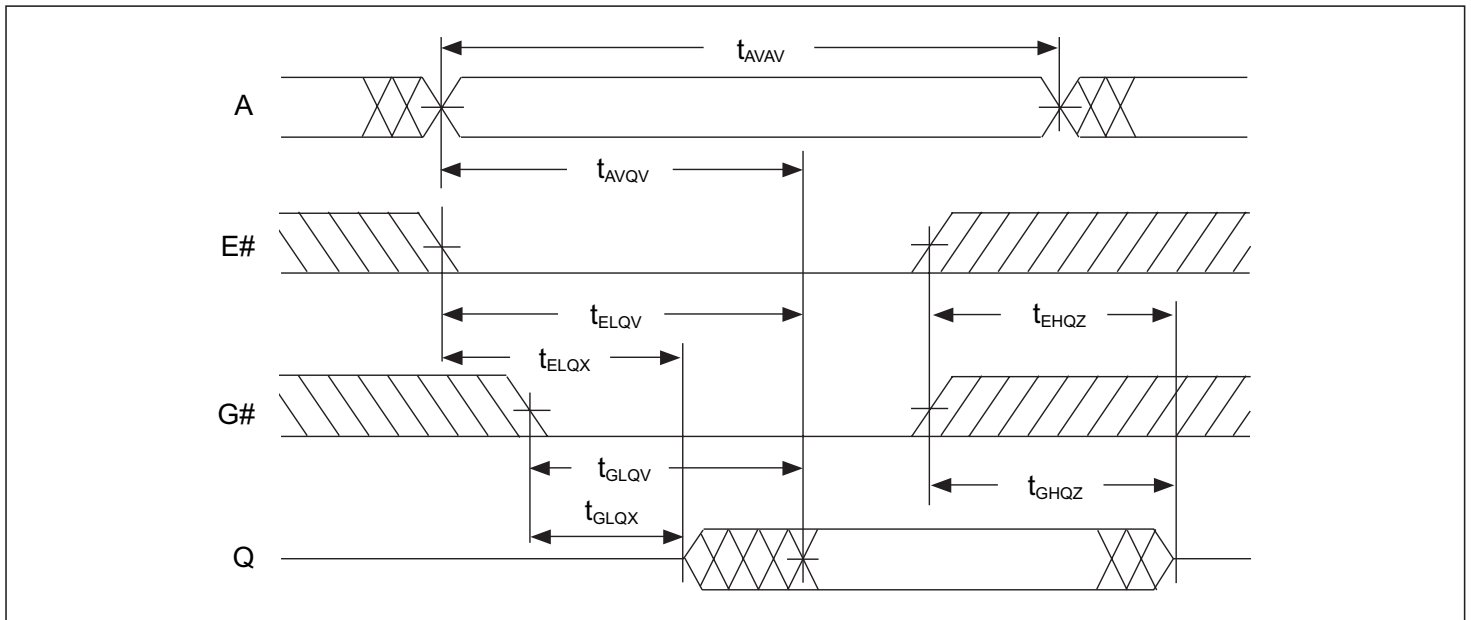

White Electronic Designs Corp. reserves the right to change products or specifications without notice.

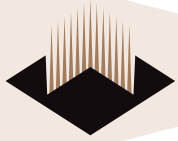

AC CHARACTERISTICS – WRITE CYCLE

Parameter	Symbol		10ns		12ns		15ns		Units
	JEDEC	Alt.	Min	Max	Min	Max	Min	Max	
Write Cycle Time	t_{AVAV}	t_{WC}	10		12		15		ns
Chip Enable to End of Write	t_{ELWH}	t_{CW}	8		9		9		ns
	t_{ELEH}	t_{CW}	8		9		9		ns
Address Setup Time	t_{AVWL}	t_{AS}	0		0		0		ns
	t_{AVEL}	t_{AS}	0		0		0		ns
Address Valid to End of Write	t_{AVWH}	t_{AW}	8		9		10		ns
	t_{AVEH}	t_{AW}	8		9		10		ns
Write Pulse Width	t_{WLWH}	t_{WP}	8		10		11		ns
	t_{WLEH}	t_{WP}	8		10		11		ns
Write Recovery Time	t_{WHAX}	t_{WR}	0		0		0		ns
	t_{EHAX}	t_{WR}	0		0		0		ns
Data Hold Time	t_{WHDX}	t_{DH}	0		0		0		ns
	t_{EHDX}	t_{DH}	0		0		0		ns
Write to Output in High Z (1)	t_{WLQZ}	t_{WHZ}	0	5	0	6	0	7	ns
Data to Write Time	t_{DVWH}	t_{DW}	6		6		7		ns
	t_{DVEH}	t_{DW}	6		6		7		ns
Output Active from End of Write (1)	t_{WHQX}	t_{WLZ}	3		3		3		ns

Note 1: Parameter guaranteed, but not tested.

WRITE CYCLE – W# CONTROLLED

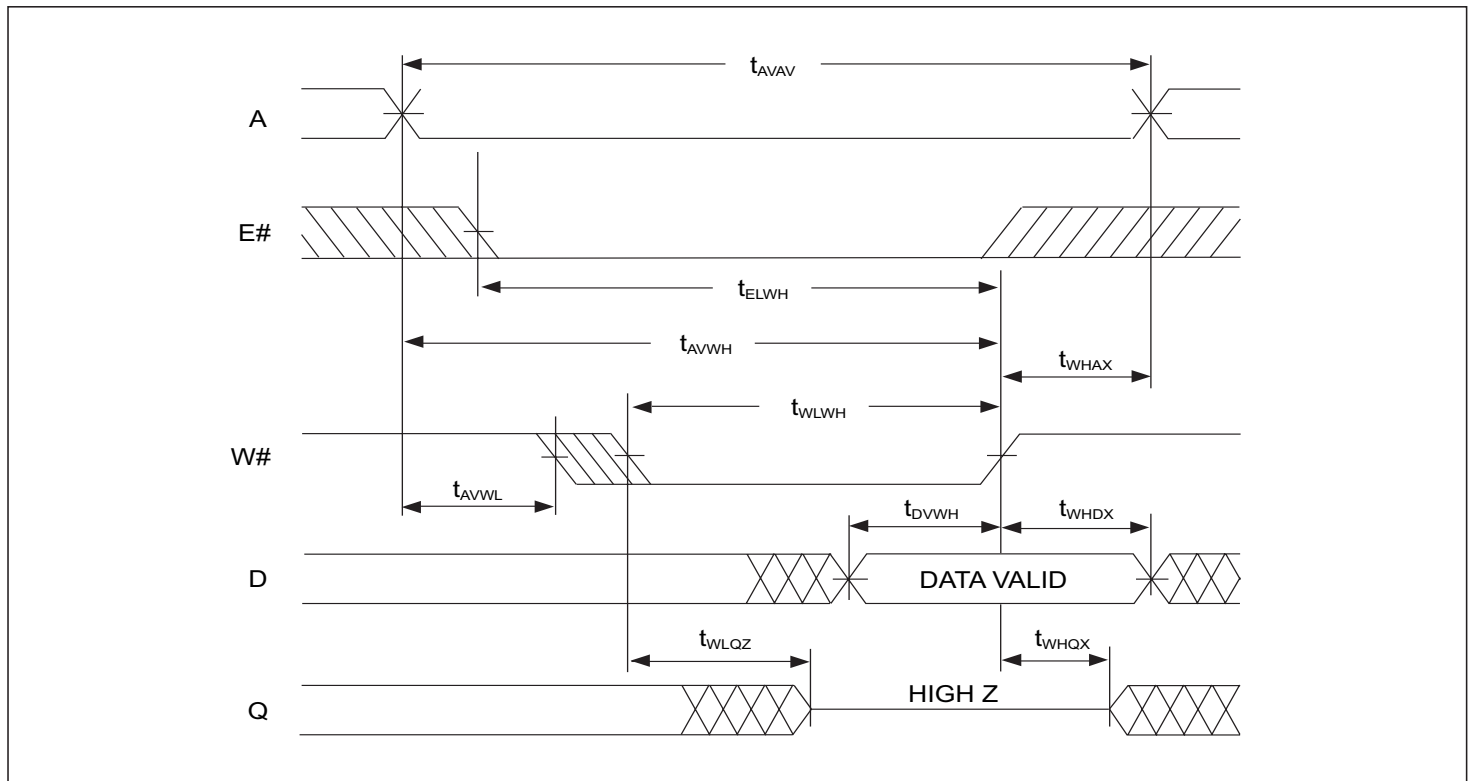

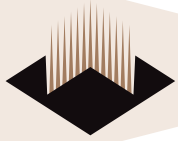

WRITE CYCLE 2 – E# CONTROLLED

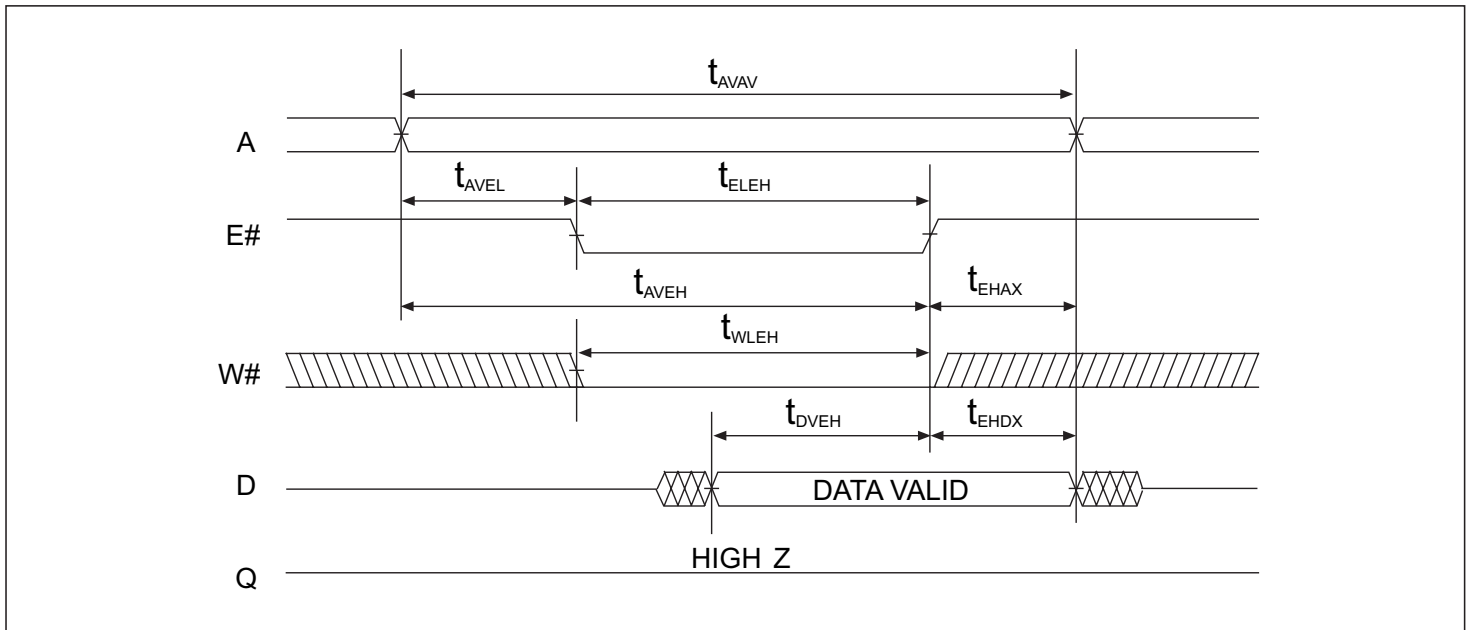

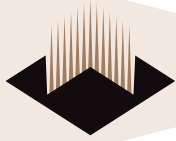

PACKAGE DESCRIPTION

Package No. 391
119 Lead BGA
JEDEC MO-163

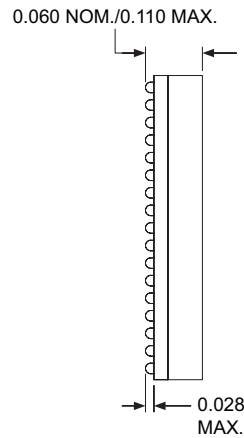
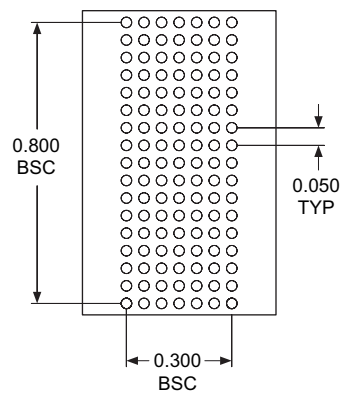
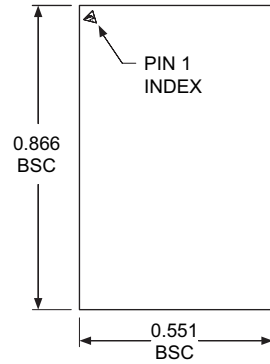

ORDERING INFORMATION

Commercial (0°C to +70°C)

Part Number	Speed (ns)	Package No.
EDI8L24129V10BC	10	391
EDI8L24129V12BC	12	391
EDI8L24129V15BC	15	391

Industrial (-40°C to +85°C)

Part Number	Speed (ns)	Package No.
EDI8L24129V10BI	10	391
EDI8L24129V12BI	12	391
EDI8L24129V15BI	15	391

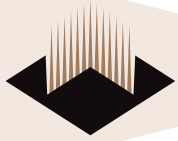

FIGURE 3 – INTERFACING THE MOTOROLA DSP5630X DSP FAMILY WITH THE EDI8L24129V (128KX24)

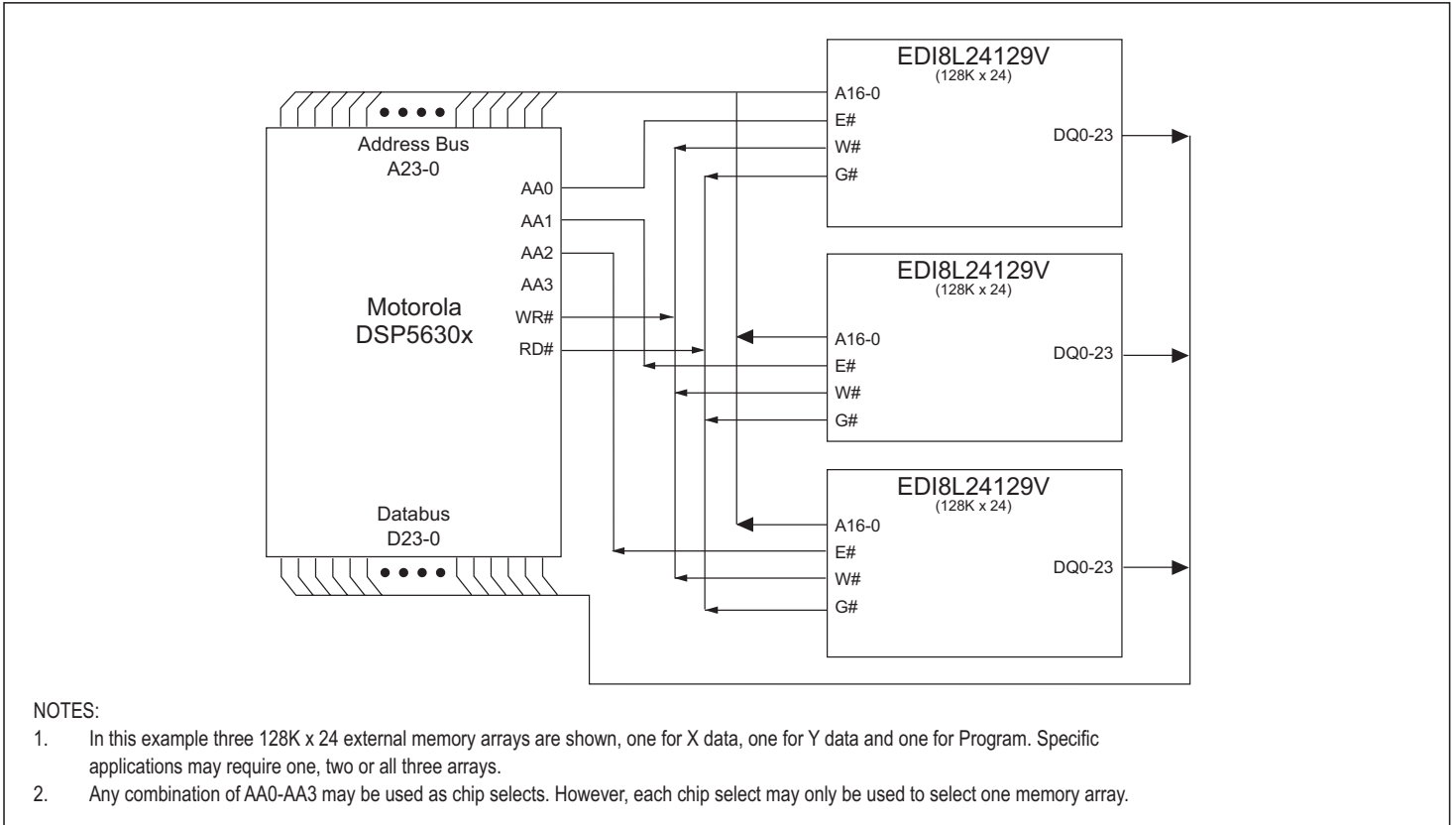
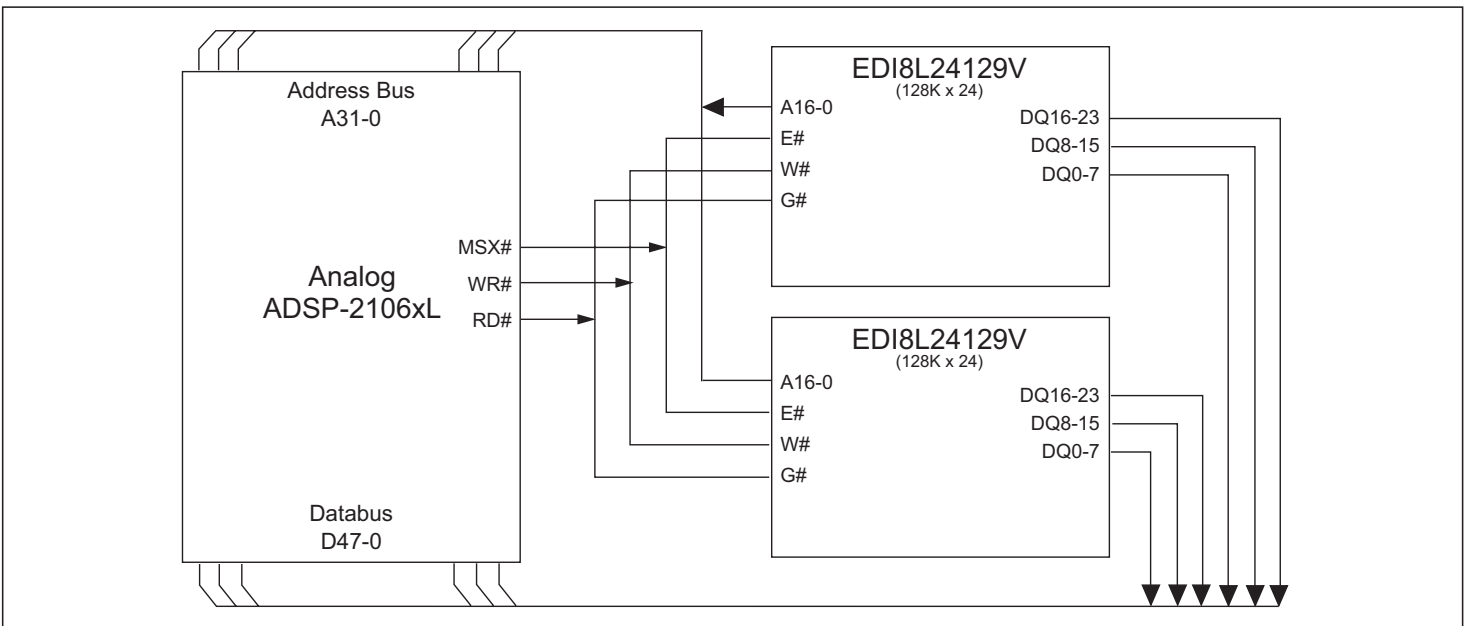

FIGURE 4 – INTERFACING THE 21060L OR THE 21062L TO THE EDI8L24129V, 119 BGA (CREATING A 128KX48 MEMORY ARRAY)



White Electronic Designs Corp. reserves the right to change products or specifications without notice.