

64Kx16 CMOS, High Speed Programmable, Static RAM Module

The EDI8M1665C is a 1024K-bit high speed CMOS Static RAM Module consisting of four (4) 64Kx4 Static RAMs in leadless chip carriers surface-mounted onto a multilayered ceramic substrate. Four Chip Select lines (one for each 64Kx4) allow the user to configure the memory into a 64Kx16, 128Kx8 or 256Kx4 organizations.

The EDI8M1665C is available with access times as fast as 35ns. The high density module, a 40 pin sidebrazed DIP on 900 mil centers, is a pin for pin replacement for EDI's EDH816H64C module.

All inputs and outputs are TTL compatible and operate from a single 5V supply. Dual ground pins are provided for maximum noise immunity.

Fully asynchronous circuitry requires no clocks or refreshing for operation.

EDI Military Modules are constructed using semiconductor components which are compliant to MIL-STD-883, paragraph 1.2.1.

Features

High Density 1024K-bit CMOS Static Random Access Memory Module

- Access Times 35, 45, 55, and 70ns
- Fully Static, No Clocks
- Inputs and Outputs Directly TTL Compatible
- Customer Configured Memory, as 64Kx16, 128Kx8 or 256Kx4

40 Pin Dual-in-line Package, No. 98

- Dual Ground Pins for Maximum Noise Immunity

Single +5V ($\pm 10\%$) Supply Operation

Pin Names

A0-A15	Address Inputs
$\overline{E0}$ - $\overline{E3}$	Chip Enables
W	Write Enable
DQ0-DQ15	Data Input/Output
VCC	Power (+5V $\pm 10\%$)
VSS	Ground

Pin Configuration and Block Diagram

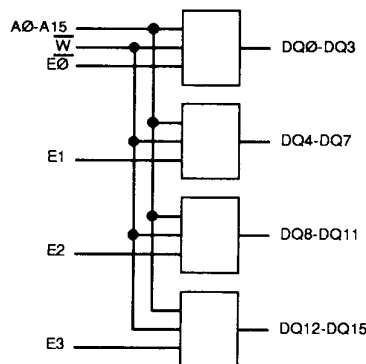
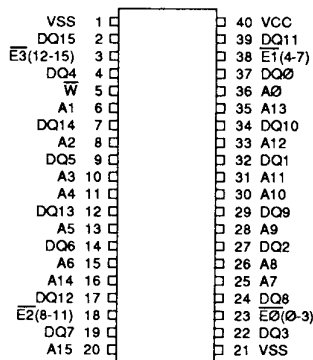

(1)

Absolute Maximum Ratings*

Voltage on any pin relative to VSS -0.5V to 7.0V
 Operating Temperature TA (Ambient)
 Commercial 0°C to +70°C
 Industrial -40°C to +85°C
 Military -55°C to +125°C
 Storage Temperature, Ceramic -65°C to +150°C
 Power Dissipation 8 Watts
 Output Current 20 mA

*Stress greater than those listed under "Absolute Maximum Ratings" may cause permanent damage to the device. This is a stress rating only and functional operation of the device at these or any other conditions greater than those indicated in the operational sections of this specification is not implied. Exposure to absolute maximum rating conditions for extended periods may affect reliability.

Recommended DC Operating Conditions

Parameter	Sym	Min	Typ	Max	Units
Supply Voltage	VCC	4.5	5.0	5.5	V
Supply Voltage	VSS	0	0	0	V
Input High Voltage	VIH	2.2	--	6.0	V
Input Low Voltage	VIL	-0.3	--	0.8	V

AC Test Conditions

Input Pulse Levels VSS to 3.0V
 Input Rise and Fall Times 5ns
 Input and Output Timing Levels 1.5V
 Output Load 1TTL, CL = 30pF
 (note: For TEHQZ and TWLQZ, CL = 5pF)

DC Electrical Characteristics

Parameter	Sym	Conditions	Mode	Min	Typ*	Max	Units
Operating Power Supply Current	ICC1	$\overline{W}, \overline{E} = \text{VIL}, \text{I/O} = 0\text{mA}, \text{Min Cycle}$	x16	--	320	480	mA
			x8	--	165	280	
			x4	--	85	180	
Standby (TTL) Power Supply Current	ICC2	$\overline{E} \geq \text{VIH}, \text{VIN} \leq \text{VIL} \text{ or } \text{VIN} \geq \text{VIH}$		--	10	120	mA
Full Standby Power Supply Current	ICC3	$\overline{E} \geq \text{VCC}-0.2\text{V}$ $\text{VIN} \geq \text{VCC}-0.2\text{V} \text{ or } \text{VIN} \leq 0.2\text{V}$		--	5	80	mA
Input Leakage Current	ILI	$\text{VIN} = 0\text{V to VCC}$		--	--	±10	µA
Output Leakage Current	ILO	$\text{V I/O} = 0\text{V to VCC}$		--	--	±10	µA
Output High Voltage	VOH	$\text{IOH} = -4.0\text{mA}$		2.4	--	--	V
Output Low Voltage	VOL	$\text{IOL} = 8.0\text{mA}$		--	--	0.4	V

*Typical: TA = 25°C, VCC = 5.0V

Truth Table

\overline{E}	\overline{W}	Mode	Output	Power
H	X	Standby	HIGH Z	ICC2, ICC3
L	H	Read	DOUT	ICC1
L	L	Write	HIGH Z	ICC1

Capacitance

(f=1.0MHz, VIN=VCC or VSS)

Parameter	Sym	Max	Units
Input Capacitance (Address, \overline{W})	CI	40	pF
Input Capacitance Enable Line (\overline{E})	CE	12	pF
Capacitance (DQ Lines)	CO	16	pF

These parameters are sampled, not 100% tested.

AC Characteristics
Read Cycle

Parameter	Symbol		35ns		45ns		55ns		70ns		Units
	JEDEC	ARL	Min	Max	Min	Max	Min	Max	Min	Max	
Read Cycle Time	TAVAV	TRC	35		45		55		70		ns
Address Access Time	TAVQV	TAA		35		45		55		70	ns
Chip Enable Access Time	TELQV	TACS		35		45		55		70	ns
Chip Enable to Output Low Z (1)	TELOX	TCLZ	5		5		5		5		ns
Chip Enable to Output in High Z (1)	TEHQZ	TCHZ	0	15	0	20	0	25	0	30	ns
Output Hold from Address Change	TAVQX	TOH	5		5		5		5		ns
Chip Enable to Power Up (1)	TELICCH	TPU	0		0		0		0		ns
Chip Disable to Power Down (1)	TEHCCL	TPD	0	35	0	45	0	55	0	70	ns

Note 1: Parameter guaranteed, but not tested.

Read Cycle 1
W High, E Low

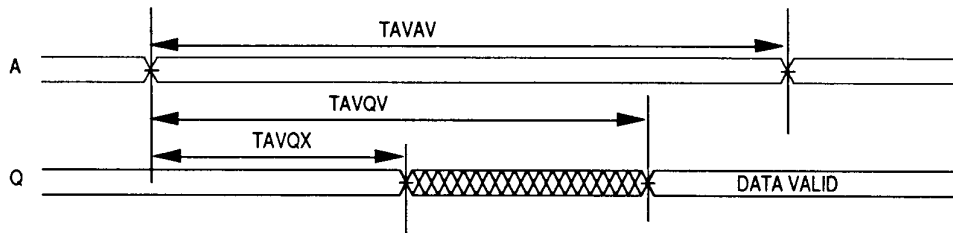

Read Cycle 2
W High

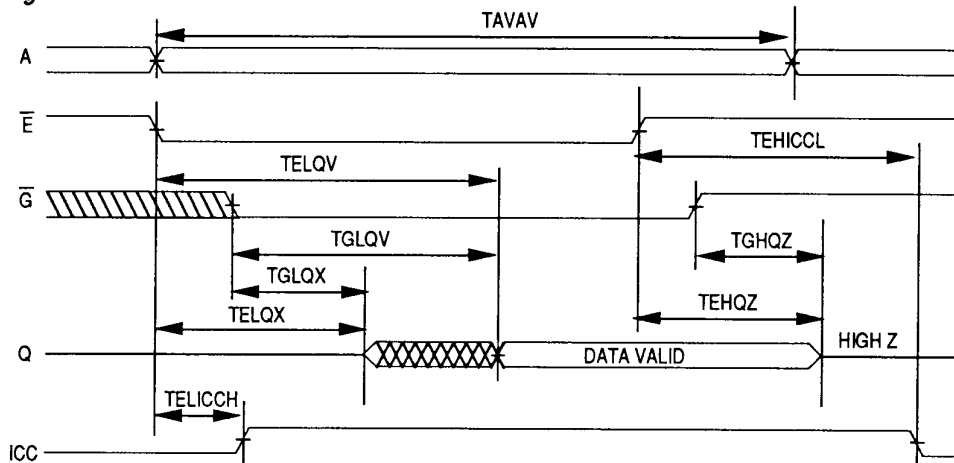

(1)

AC Characteristics
Write Cycle

Parameter	Symbol		35ns		45ns		55ns		70ns		Units
	JEDEC	Alt.	Min	Max	Min	Max	Min	Max	Min	Max	
Write Cycle Time	TAVAV	TWC	35		45		55		70		ns
Chip Enable to	TELWH	TCW	30		40		50		65		ns
End of Write	TELEH	TCW	30		40		50		65		ns
Address Setup Time	TAVWL	TAS	0		0		0		0		ns
	TAVEL	TAS	0		0		0		0		ns
Address Valid to	TAVWH	TAW	30		35		40		55		ns
End of Write	TAVEH	TAW	30		35		40		55		ns
Write Pulse Width	TWLWH	TWP	30		35		40		55		ns
	TWLEH	TWP	30		35		40		55		ns
Write Recovery Time	TWHAX	TWR	5		5		5		5		ns
	TEHAX	TWR	5		5		5		5		ns
Data Hold Time	TWHDX	TDH	0		0		0		0		ns
	TEHDX	TDH	0		0		0		0		ns
Write to Output in High Z (1)	TWLQZ	TWHZ	0	15	0	20	0	20	0	30	ns
Data to Write Time	TDVWH	TDW	15		20		20		30		ns
	TDVEH	TDW	15		20		20		30		ns
Output Active from End of Write (1)	TWHQX	TWLZ	0		0		0		0		ns

Note 1: Parameter guaranteed, but not tested.

**Write Cycle 1
W Controlled**

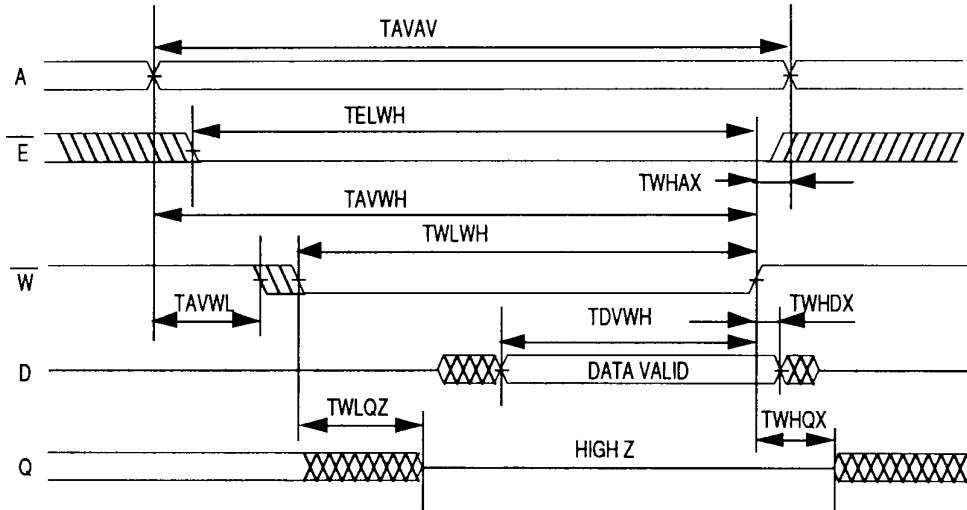

**Write Cycle 2
E Controlled**

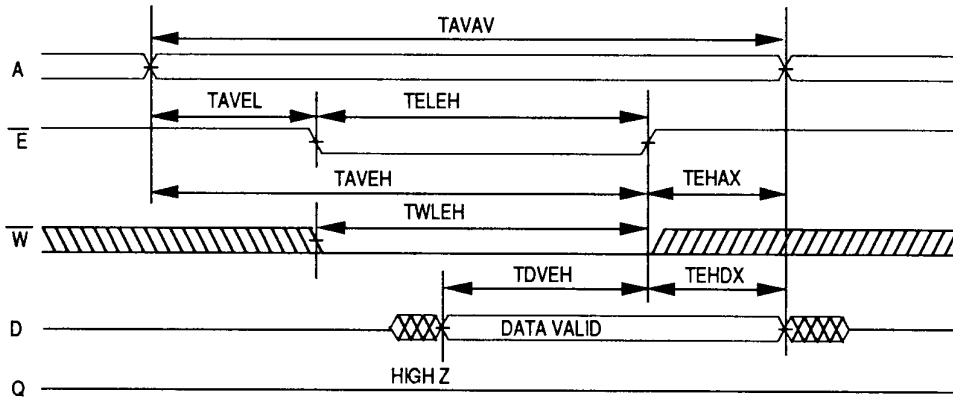

Device Configurations for 139 Decoder Applications

64Kx16 Configuration

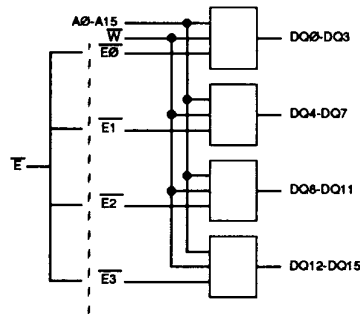

128Kx8 Configuration

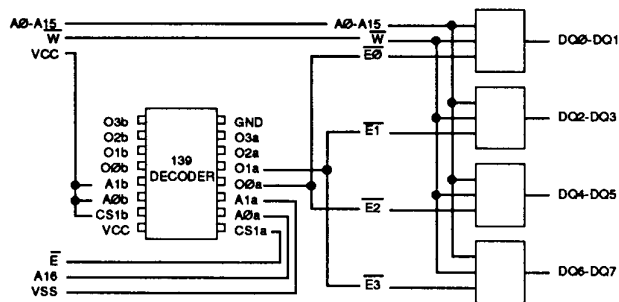

256Kx4 Configuration

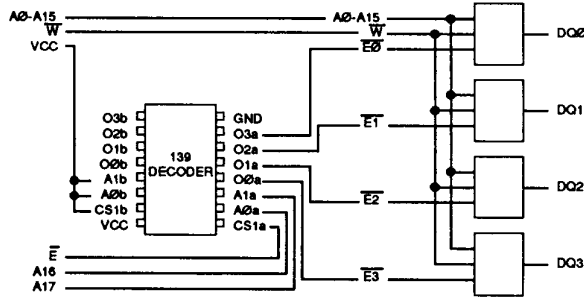

Ordering Information

Part No.	Speed (ns)	Leads	Package Style	No.
EDI8M1665C35C9B	35	40	0.9 DIP	98
EDI8M1665C45C9B	45	40	0.9 DIP	98
EDI8M1665C55C9B	55	40	0.9 DIP	98
EDI8M1665C70C9B	70	40	0.9 DIP	98