



EDI8M8130C/P90/100/120/150

High Performance Megabit SRAM Module

128Kx8 Static RAM CMOS, Module

The EDI8M8130C/P is a 1024K bit CMOS Static RAM Module based on four 32Kx8 Static RAMs in leadless chip carriers mounted on a multi-layered ceramic substrate.

The Military screened product is available in both Standard (C) and Low Power (P) versions.

The EDI8M8130C/P has an on-board decoder circuit that interprets the higher order address to select one of the 32Kx8 Static RAMs. The \bar{E} and S lines perform the chip enable functions that automatically power down the device when proper logic levels are applied.

All inputs and outputs are TTL compatible and operate from a 5V supply. Fully asynchronous, the EDI8M8130C/P requires no clocks or refreshing for operation.

EDI Military Modules are constructed using semiconductor components which have been 100% processed to the test methods of MIL-STD-883C, Class B.

Features

128Kx8 bit CMOS Static Random Access Memory

- Access Times 90, 100, 120 and 150ns
- \bar{E} , S, and \bar{G} Functions for Bus Control
- Data Retention Function
- Inputs and Outputs Directly TTL Compatible
- Fully Static, No Clocks

Jedec Approved Pinout

- 32 Pin Ceramic Dual-in-line Package

Single +5V ($\pm 10\%$) Supply Operation

Pin Configurations and Block Diagram

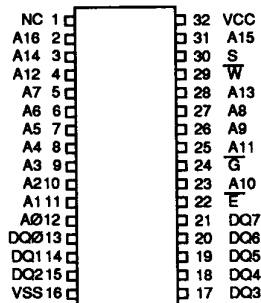

Pin Names

A0-A16	Address Inputs
\bar{E}	Chip Enable
S	Chip Select
\bar{W}	Write Enable
G	Output Enable
DQ0-DQ7	Data Input/Output
VCC	Power (+5V $\pm 10\%$)
VSS	Ground

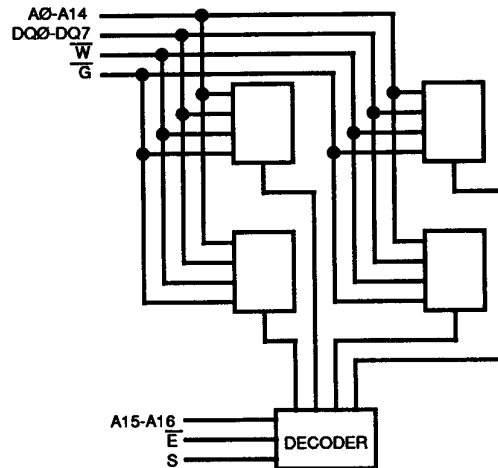

Absolute Maximum Ratings*

Voltage on any pin relative to VSS -0.5V to 7.0V
 Operating Temperature TA (Ambient)
 Commercial 0°C to +70°C
 Military -55°C to +125°C
 Storage Temperature (Ambient/Ceramic). -65°C to +150°C
 Power Dissipation 1 Watt
 Output Current 20 mA

*Stress greater than those listed under "Absolute Maximum Ratings" may cause permanent damage to the device. This is a stress rating only and functional operation of the device at these or any other conditions greater than those indicated in the operational sections of this specification is not implied. Exposure to absolute maximum rating conditions for extended periods may affect reliability.

DC Electrical Characteristics

(TA = 0°C to +70°C or -55°C to +125°C; VCC = 5.0V ±10%)

Parameter	Sym	Conditions	Min	Typ*	Max	Units	
Operating Power Supply Current	ICC1	$\overline{W}, \overline{E} = \text{VIL}, I/O = 0\text{mA}, \text{Min Cycle}$ $S = \text{VIH}, \text{Min Cycle}$	--	70	95	mA	
Standby (TTL) Power Supply Current	ICC2	$\overline{E} \geq \text{VIH}$ or $S \leq \text{VIL}$	--	10	25	mA	
Full Standby Power Supply Current	ICC3	$\overline{E} \geq \text{VCC} - 0.2\text{V}$ or $S \leq 0.2\text{V}$ $\text{VIN} \geq \text{VCC} - 0.2\text{V}$ or $\text{VIN} \leq 0.2\text{V}$	C	--	1	3	mA
			P	--	50	900	µA
Input Leakage Current	IIL	$\text{VIN} = 0\text{V}$ to VCC	--	--	±10	µA	
Output Leakage Current	IOL	$V I/O = 0\text{V}$ to VCC; $\overline{E}, \overline{G} = \text{VIH}$ or $S = \text{VIL}$	--	--	±10	µA	
Output High Voltage	VOH	$\text{IOH} = -4.0\text{mA}$	2.4	--	--	V	
Output Low Voltage	VOL	$\text{IOL} = 8.0\text{mA}$	--	--	0.4	V	

*Typical: TA = 25°C, VCC = 5.0V

Truth Table

\overline{G}	\overline{E}	S	\overline{W}	Mode	Output	Power
X	H	X	X	Standby	High Z	ICC2, ICC3
X	X	L	X	Standby	High Z	ICC2, ICC3
H	L	H	H	Output Deselect	High Z	ICC1
L	L	H	H	Read	DOU	ICC1
X	L	H	L	Write	DIN	ICC1

Recommended DC Operating Conditions

Parameter	Sym	Min	Typ	Max	Units
Supply Voltage	VCC	4.5	5.0	5.5	V
Supply Voltage	VSS	0	0	0	V
Input High Voltage	VIH	2.2	--	6.0	V
Input Low Voltage	VIL	-0.3	--	0.8	V

AC Test Conditions

Input Pulse Levels VSS to 3.0V
 Input Rise and Fall Times 5ns
 Input and Output Timing Levels 1.5V
 Output Load 1TTL, CL = 30pF
 (note: For TEHQZ, TGHQZ and TWLQZ, CL = 5pF)

Capacitance

(f=1.0MHz, VIN=VCC or VSS)

Parameter	Sym	Max	Unit
Input Capacitance (Except DQ Pins)	CI	50	pF
Capacitance Control (DQ Pins)	CD/Q	43	pF
Input Capacitance Control Lines (\overline{E} , S)	CC	10	pF
Input Capacitance \overline{W} Line	CW	50	pF

Note: These parameters are sampled, not 100% tested.

AC Characteristics

Read Cycle

(TA = 0°C to +70°C or -55°C to +125°C; VCC = 5.0V ±10%)

Parameter	Symbol	90ns		100ns		120ns		150ns		Units
		Min	Max	Min	Max	Min	Max	Min	Max	
Read Cycle Time	TAVAV	90		100		120		150		ns
Address Access Time	TAVQV		90		100		120		150	ns
Chip Enable Access Time	TELQV \bar{E}		90		100		120		150	ns
	TSHQV S		90		100		120		150	ns
Chip Enable to Output in Low Z (1)	TELQX \bar{E}	30		30		30		30		ns
	TSHQX S	30		30		30		30		ns
Chip Disable to Output in High Z (1)	TEHQZ \bar{E}		30		30		40		50	ns
	TSLQZ S		30		30		40		50	ns
Output Hold from Address Change	TAVQX	10		10		10		10		ns
Output Enable to Output Valid	TGLQV		50		50		60		70	ns
Output Enable to Output in Low Z (1)	TGLQX	10		10		10		10		ns
Output Disable to Output in High Z (1)	TGHQZ		30		30		40		50	ns

Note 1: Parameter guaranteed, but not tested.

Read Cycle 1 W, S High; \bar{G} , \bar{E} Controlled

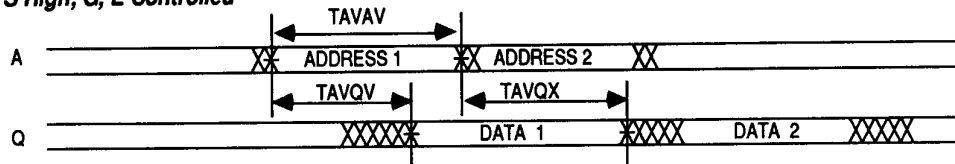

Read Cycle 2 W High

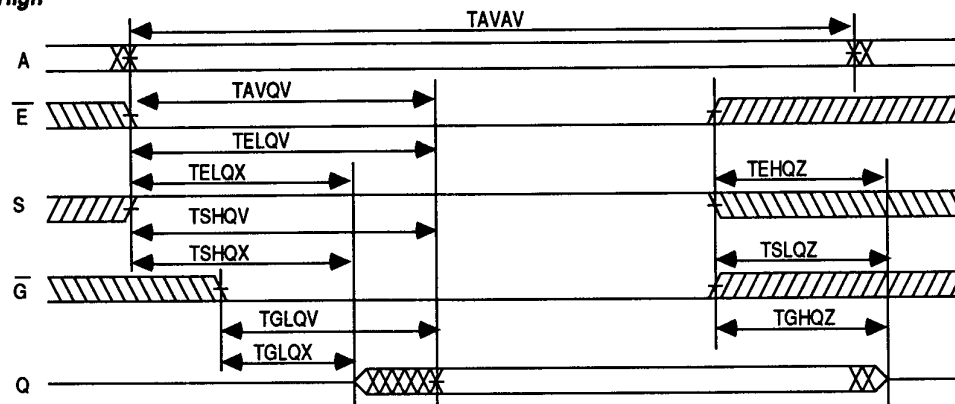

(4)

ED18M8130C/P90/100/120/150 Rev. 1.0 2/89 117

AC Characteristics

Write Cycle

(TA = 0°C to +70°C or -55°C to +125°C; VCC = 5.0V ±10%)

Parameter	Symbol		90ns		100ns		120ns		150ns		Units
			Min	Max	Min	Max	Min	Max	Min	Max	
Write Cycle Time	TAVAV		90		100		120		150		ns
Chip Enable to	TELWH	\overline{E}	80		80		90		110		ns
End of Write	TSHWH	S	80		80		90		110		ns
Address Setup Time	TAVWL	\overline{W}	20		20		20		20		ns
	TAVEL	\overline{E}	0		0		0		0		ns
	TAVSH	S	0		0		0		0		ns
Address Valid to											
End of Write	TAVWH		80		80		90		110		ns
Write Pulse Width	TWLWH	\overline{W}	60		60		70		80		ns
	TELEH	\overline{E}	60		60		70		80		ns
	TSHSL	S	60		60		70		80		ns
Write Recovery Time	TWHAX	\overline{W}	0		0		0		0		ns
	TEHAX	\overline{E}	20		20		20		20		ns
	TSLAX	S	20		20		20		20		ns
Data Hold Time	TWHDX	\overline{W}	0		0		0		0		ns
	TEHDX	\overline{E}	20		20		20		20		ns
	TSLDX	S	20		20		20		20		ns
Write to Output in High Z (1)	TWLQZ		0	35	0	35	0	35	0	45	ns
Data to Write Time	TDVWH	\overline{W}	35		35		40		50		ns
	TDVEH	\overline{E}	35		35		40		50		ns
	TDVSL	S	35		35		40		50		ns
Output Active from End of Write (1)	TWHQX		0		0		0		0		ns

Note 1: Parameter guaranteed, but not tested.

Write Cycle 1
Late Write, \bar{W} Controlled

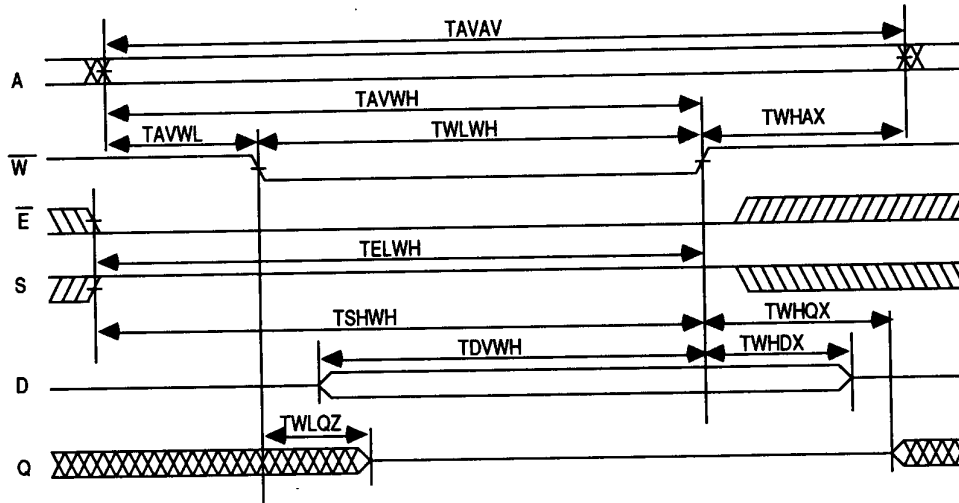

Write Cycle 2
Early Write, E Controlled

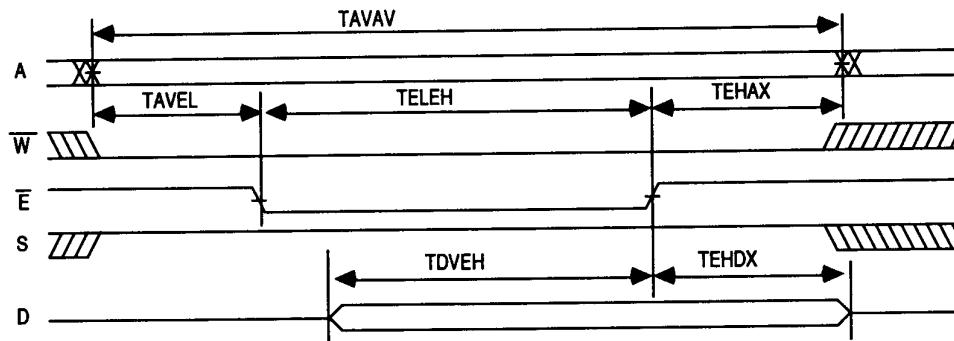

Write Cycle 3
Early Write, S Controlled

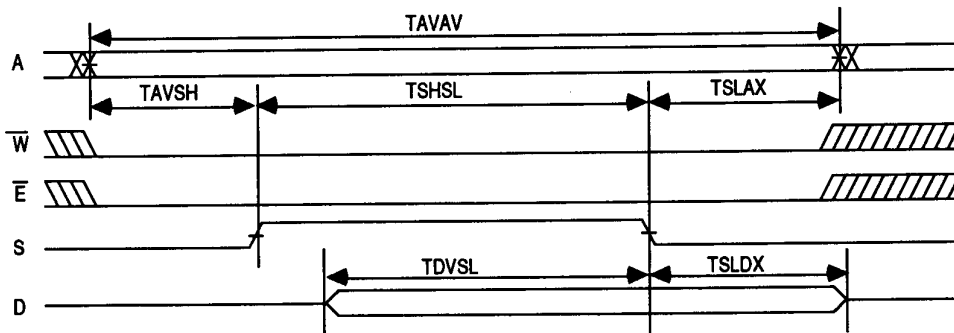

Data Retention Characteristics

(TA = 0°C to +70°C or -55°C to +125°C)

Characteristic	Sym	Test Conditions	Min	Typ	Max	Unit	
Data Retention Voltage	VDD	VDD = 2.0V	2	--	--	V	
Data Retention Quiescent Current	ICCDR	$\bar{E} \geq VDD - 0.2V$ $S \leq 0.2V$	C	--	500	1500	μA
			P	--	100	500	μA
Chip Disable to Data Retention Time	TCDR	VIN \geq VDD - 0.2V	0	--	--	ns	
Operation Recovery Time	TR	or VIN \leq 0.2V	TAVAV*	--	--	ns	

*Read Cycle Time

**Data Retention
 \bar{E} Controlled**

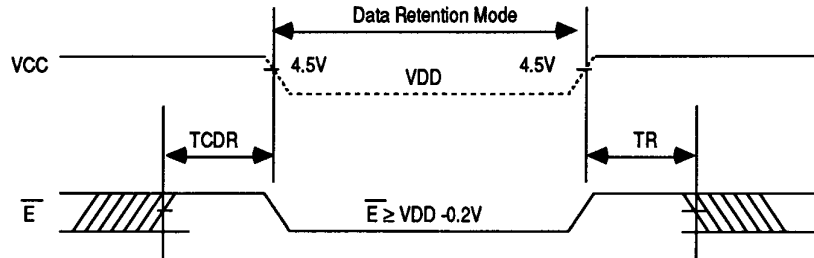

**Data Retention
S Controlled**

