



128Kx48 3.3V SRAM MODULE ADVANCED*

FEATURES

- Access Times 15, 17, 20, 25ns
- Packaging
 - 116 Lead, 40.0mm Hermetic CQFP (Package 504)
- Commercial, Industrial and Military Temperature Ranges
- 3.3 Volt Power Supply
- Low Power CMOS
- Organized as 128K x 48, Data Width is user configurable.

- 2V Data Retention Devices Available (Low Power Version)
- TTL Compatible Inputs and Outputs
- Weight
WS128K48V-XG4WX - 20 grams typical

** This data sheet describes a product that may or may not be under development and is subject to change or cancellation without notice.*

PIN CONFIGURATION FOR WS128K48V-XG4WX

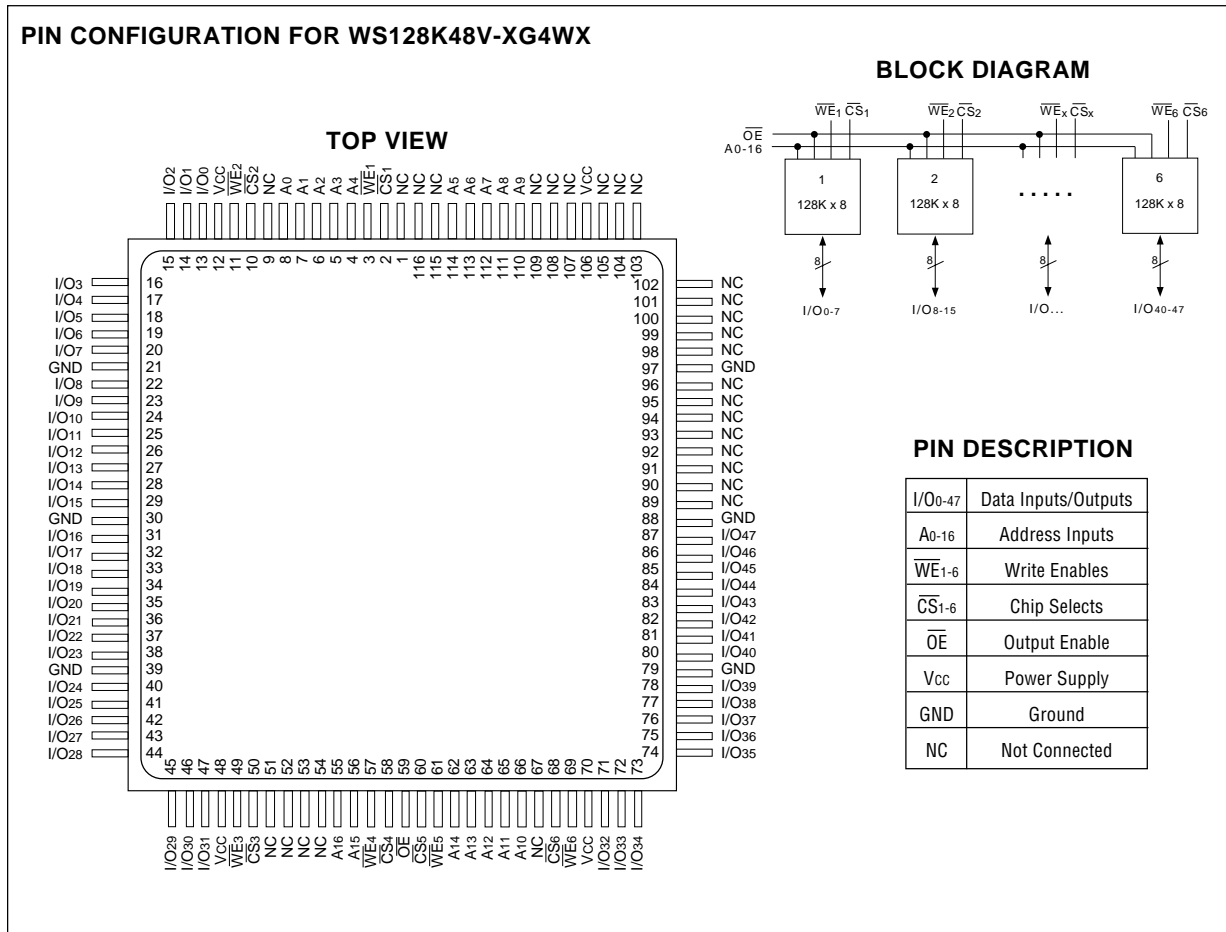

**ABSOLUTE MAXIMUM RATINGS**

Parameter	Symbol	Min	Max	Unit
Operating Temperature	T _A	-55	+125	°C
Storage Temperature	T _{STG}	-65	+150	°C
Signal Voltage Relative to GND	V _G	-0.5	4.6	V
Junction Temperature	T _J		150	°C
Supply Voltage	V _{CC}	-0.5	4.6	V

RECOMMENDED OPERATING CONDITIONS

Parameter	Symbol	Min	Max	Unit
Supply Voltage	V _{CC}	3.0	3.6	V
Input High Voltage	V _{IH}	2.2	V _{CC} + 0.3	V
Input Low Voltage	V _{IL}	-0.3	+0.8	V
Operating Temp. (Mil.)	T _A	-55	+125	°C

TRUTH TABLE

\overline{CS}	\overline{OE}	\overline{WE}	Mode	Data I/O	Power
H	X	X	Standby	High Z	Standby
L	L	H	Read	Data Out	Active
L	X	L	Write	Data In	Active
L	H	H	Out Disable	High Z	Active

CAPACITANCE(T_A = +25°C)

Parameter	Symbol	Conditions	Max	Unit
\overline{OE} capacitance	C _{OE}	V _{IN} = 0 V, f = 1.0 MHz	100	pF
\overline{WE} capacitance	C _{WE}	V _{IN} = 0 V, f = 1.0 MHz	20	pF
\overline{CS} capacitance	C _{CS}	V _{IN} = 0 V, f = 1.0 MHz	20	pF
Data I/O capacitance	C _{I/O}	V _{I/O} = 0 V, f = 1.0 MHz	20	pF
Address input capacitance	C _{AD}	V _{IN} = 0 V, f = 1.0 MHz	100	pF

This parameter is guaranteed by design but not tested.

DC CHARACTERISTICS(V_{CC} = 3.3V ± 0.3V, T_A = -55°C to +125°C)

Parameter	Sym	Conditions			Units
			Min	Max	
Input Leakage Current	I _{LI}	V _{IN} = GND to V _{CC}		10	μA
Output Leakage Current	I _{LO}	\overline{CS} = V _{IH} , \overline{OE} = V _{IH} , V _{OUT} = GND to V _{CC}		10	μA
Operating Supply Current	I _{CC}	\overline{CS} = V _{IL} , \overline{OE} = V _{IH} , f = 5MHz, V _{CC} = 3.6		750	mA
Standby Current	I _{SB}	\overline{CS} = V _{IH} , \overline{OE} = V _{IH} , f = 5MHz, V _{CC} = 3.6		48	mA
Output Low Voltage	V _{OL}	I _{OL} = 8mA		0.4	V
Output High Voltage	V _{OH}	I _{OH} = -4.0mA	2.4		V

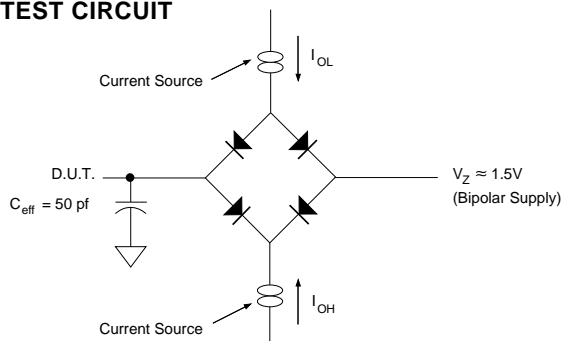
NOTE: DC test conditions: V_{IH} = V_{CC} - 0.3V, V_{IL} = 0.3V**AC TEST CIRCUIT****AC TEST CONDITIONS**

Parameter	Typ	Unit
Input Pulse Levels	V _{IL} = 0, V _{IH} = 2.5	V
Input Rise and Fall	5	ns
Input and Output Reference Level	1.5	V
Output Timing Reference Level	1.5	V

NOTES:

V_Z is programmable from -2V to +7V.
I_{OL} & I_{OH} programmable from 0 to 16mA.
Tester Impedance Z₀ = 75 Ω.
V_Z is typically the midpoint of V_{OH} and V_{OL}.
I_{OL} & I_{OH} are adjusted to simulate a typical resistive load circuit.
ATE tester includes jig capacitance.



AC CHARACTERISTICS
(V_{CC} = 3.3V ± 0.3V, T_A = -55°C To +125°C)

Parameter	Symbol	-15		-17		-20		-25		Units
		Min	Max	Min	Max	Min	Max	Min	Max	
Read Cycle Time	t _{RC}	15		17		20		25		ns
Address Access Time	t _{AA}		15		17		20		25	ns
Output Hold from Address Change	t _{OH}	0		0		0		0		ns
Chip Select Access Time	t _{ACS}		15		17		20		25	ns
Output Enable to Output Valid	t _{OE}		10		10		12		15	ns
Chip Select to Output in Low Z	t _{CLZ} ¹	3		3		3		3		ns
Output Enable to Output in Low Z	t _{OLZ} ¹	0		0		0		0		ns
Chip Disable to Output in High Z	t _{CHZ} ¹		10		10		12		12	ns
Output Disable to Output in High Z	t _{OHZ} ¹		10		10		12		12	ns

1. This parameter is guaranteed by design but not tested.

AC CHARACTERISTICS
(V_{CC} = 3.3V ± 0.3V, T_A = -55°C To +125°C)

Parameter	Symbol	-15		-17		-20		-25		Units
		Min	Max	Min	Max	Min	Max	Min	Max	
Write Cycle Time	t _{WC}	15		17		20		25		ns
Chip Select to End of Write	t _{CW}	14		14		15		20		ns
Address Valid to End of Write	t _{AW}	14		15		15		20		ns
Data Valid to End of Write	t _{DW}	10		10		12		15		ns
Write Pulse Width	t _{WP}	14		14		15		20		ns
Address Setup Time	t _{AS}	0		0		0		0		ns
Address Hold Time	t _{AH}	0		0		0		0		ns
Output Active from End of Write	t _{OW} ¹	3		3		3		3		ns
Write Enable to Output in High Z	t _{WHZ} ¹		10		10		12		15	ns
Data Hold Time	t _{DH}	0		0		0		0		ns

1. This parameter is guaranteed by design but not tested.



TIMING WAVEFORM - READ CYCLE

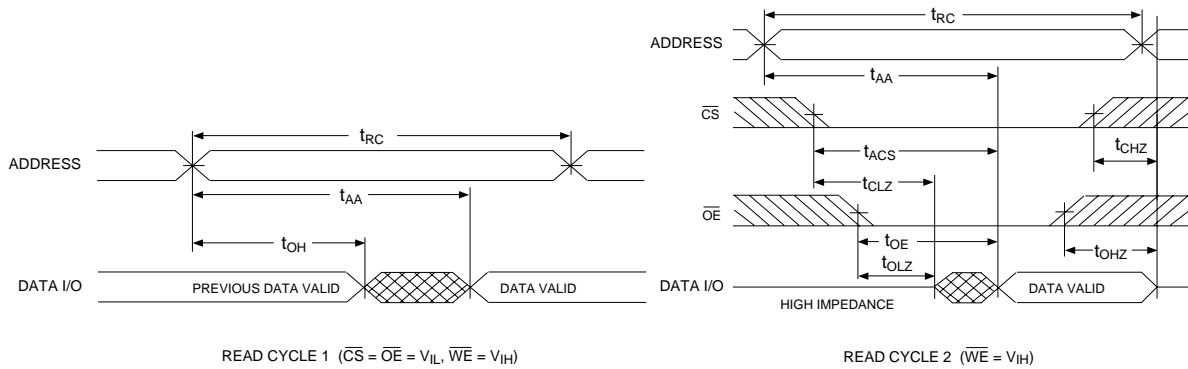

WRITE CYCLE - \overline{WE} CONTROLLED

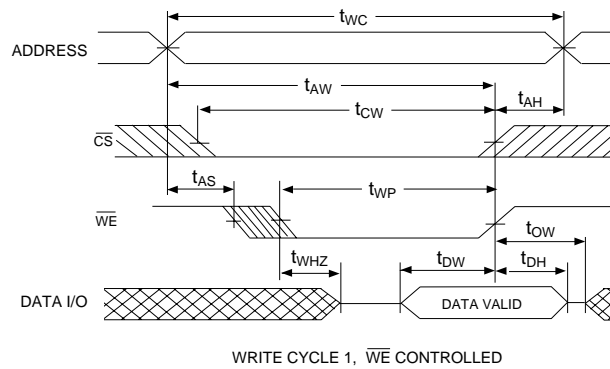

WRITE CYCLE - \overline{CS} CONTROLLED

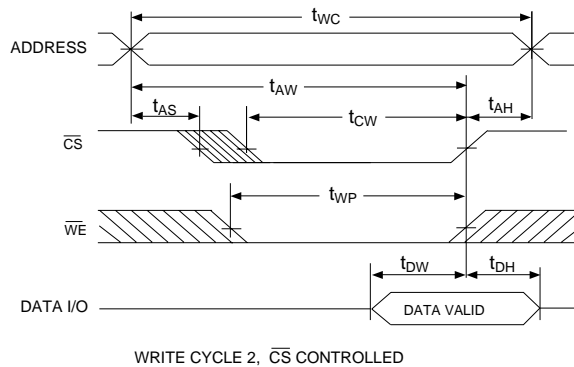



PACKAGE 504: 116 LEAD, CERAMIC QUAD FLAT PACK, CQFP (G4W)

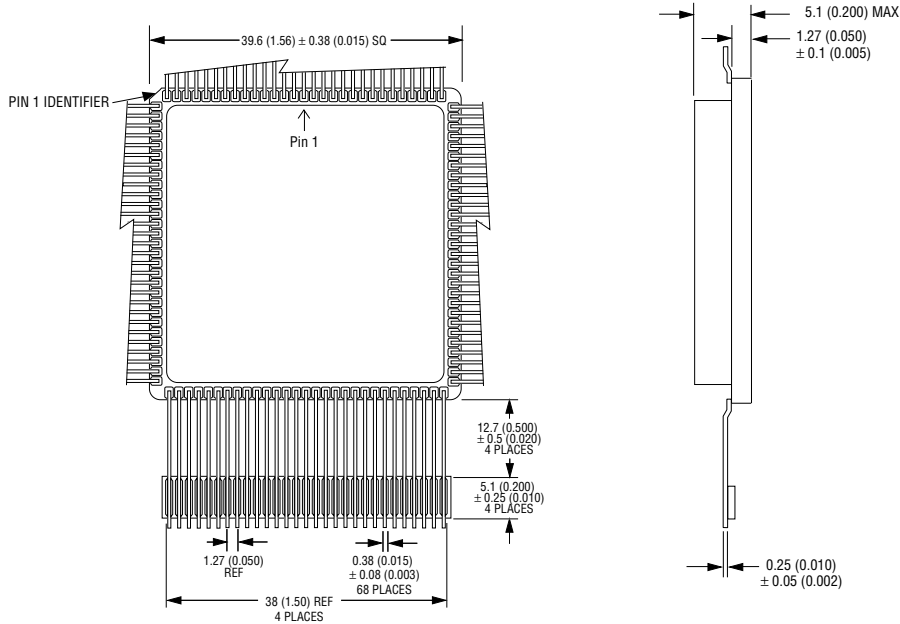

ALL LINEAR DIMENSIONS ARE MILLIMETERS AND PARENTHETICALLY IN INCHES

ORDERING INFORMATION

W S 128K48 V - XXX G4W X

DEVICE GRADE:

- M = Military Screened -55°C to +125°C
- I = Industrial -40°C to +85°C
- C = Commercial 0°C to +70°C

PACKAGE TYPE:

G4W = 116 Lead 40mm Ceramic Quad Flat Pack, CQFP (Package 504)

ACCESS TIME (ns)

Low Voltage Supply 3.3V ± 10%

ORGANIZATION, 128K x 48

SRAM

WHITE MICROELECTRONICS