

32 Mbit (2Mb x16) 1.8V Asynchronous PSRAM

FEATURES SUMMARY

- SUPPLY VOLTAGE: 1.65 to 1.95V
- ACCESS TIMES: 70ns, 80ns, 85ns
- LOW STANDBY CURRENT: 100 μ A
- DEEP POWER-DOWN CURRENT: 10 μ A
- BYTE CONTROL: $\overline{UB}/\overline{LB}$
- PROGRAMMABLE PARTIAL ARRAY
- COMPATIBLE WITH STANDARD LPSRAM
- TRI-STATE COMMON I/O
- 8 WORD PAGE ACCESS CAPABILITY: 25ns
- WIDE OPERATING TEMPERATURE
 - $T_A = -30$ to $+85^\circ\text{C}$
- PARTIAL POWER-DOWN MODES
 - Deep Power-Down
 - 4 Mbit Partial Power-Down
 - 8 Mbit Partial Power-Down
 - 16 Mbit Partial Power-Down

Figure 1. Package

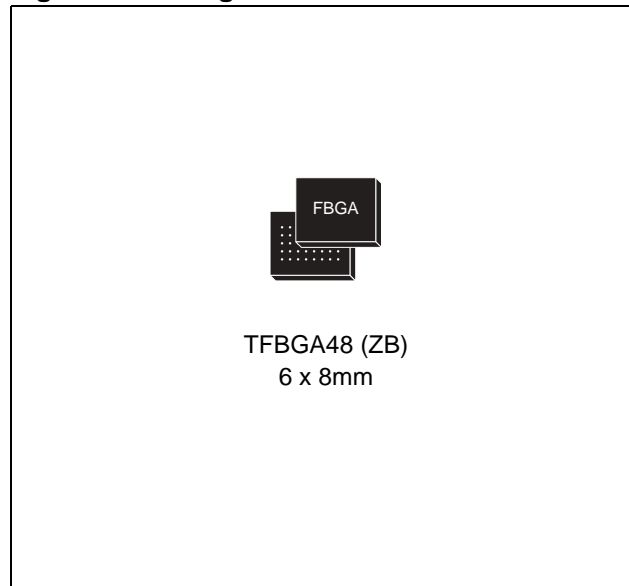

| | |
|--|----------|
| FEATURES SUMMARY | 1 |
| Figure 1. Package | 1 |
| SUMMARY DESCRIPTION | 4 |
| Figure 2. Logic Diagram | 4 |
| Table 1. Signal Names | 4 |
| Figure 3. TFPGA Connections (Top view through package) | 5 |
| SIGNAL DESCRIPTIONS | 6 |
| Address Inputs (A0-A20) | 6 |
| Data Inputs/Outputs (DQ8-DQ15) | 6 |
| Data Inputs/Outputs (DQ0-DQ7) | 6 |
| Chip Enable ($\overline{E1}$) | 6 |
| Chip Enable (E2) | 6 |
| Output Enable (\overline{G}) | 6 |
| Write Enable (\overline{W}) | 6 |
| Upper Byte Enable (\overline{UB}) | 6 |
| Lower Byte Enable (\overline{LB}) | 6 |
| V _{CC} Supply Voltage | 6 |
| V _{SS} Ground | 6 |

Figure 4. Block Diagram 7

OPERATION 8

Power Up Sequence 8

Read Mode 8

Write Mode 8

Standby Mode 8

Power-Down Modes 8

 Description 8

 Power-Down Program Sequence 8

 Table 2. Operating Modes 9

 Table 3. Power-Down Modes 9

 Table 4. Power-Down Program Sequence 10

 Table 5. Power-Down Configuration Data 10

 Table 6. Power-Down Configuration Addresses 10

MAXIMUM RATING 11

 Table 7. Absolute Maximum Ratings 11

DC and AC PARAMETERS 12

 Table 8. Operating and AC Measurement Conditions 12

 Figure 5. AC Measurement Load Circuit 1 12

 Figure 6. AC Measurement Load Circuit 2 12

 Table 9. Capacitance 12

 Figure 7. AC Measurement I/O Waveform 13

 Table 10. DC Characteristics 13

 Table 11. Read Mode AC Characteristics 14

 Figure 8. Address Controlled, Read Mode AC Waveforms 15

 Figure 9. Address and Output Enable Controlled, Read Mode AC Waveforms 15

 Figure 10. $\overline{UB}/\overline{LB}$ Controlled, Read Mode AC Waveforms 16

 Figure 11. Page Address and Chip Enable Controlled, Read Mode AC Waveforms 16

 Figure 12. Random and Page Address Controlled, Read Mode AC Waveforms 17

 Table 12. Write Mode AC Characteristics 18

 Figure 13. Chip Enable Controlled, Write AC Waveforms 19

 Figure 14. Write Enable Controlled, Write AC Waveforms 19

 Figure 15. Write Enable and $\overline{UB}/\overline{LB}$ Controlled, Write AC Waveforms 1 20

 Figure 16. Write Enable and $\overline{UB}/\overline{LB}$ Controlled, Write AC Waveforms 2 20

 Figure 17. Write Enable and $\overline{UB}/\overline{LB}$ Controlled, Write AC Waveforms 3 21

 Figure 18. Write Enable and $\overline{UB}/\overline{LB}$ Controlled, Write AC Waveforms 4 21

 Figure 19. Chip Enable Controlled, Read and Write Mode AC Waveforms 22

 Figure 20. Chip Enable, Write Enable, Output Enable Controlled, Read/Write AC Waveforms. . . . 22

 Figure 21. Output Enable and Write Enable Controlled, Read and Write Mode AC Waveforms . . . 23

 Figure 22. Output Enable, Write Enable and $\overline{UB}/\overline{LB}$ Controlled, Read/Write AC Waveforms 23

 Table 13. Standby Mode AC Characteristics 24

 Figure 23. Power-Down Programming AC Waveforms 24

 Figure 24. Power-Down Mode AC Waveforms 25

Figure 25.Power-Up Mode AC Waveforms 25
Figure 26.Standby Mode Entry AC Waveforms, After Read 25

PACKAGE MECHANICAL 26
Figure 27.TFBGA48 6x8mm - 6x8 ball array, 0.75 mm pitch, Package Outline, Bottom View 26
Table 14. TFBGA48 6x8mm - 6x8 ball array, 0.75 mm pitch, Package Mechanical Data. 26

PART NUMBERING 27
Table 15. Ordering Information Scheme 27

REVISION HISTORY..... 28
Table 16. Document Revision History 28

SUMMARY DESCRIPTION

The M69AR048B is a 32 Mbit (33,554,432 bit) CMOS memory, organized as 2,097,152 words by 16 bits, and is supplied by a single 1.65V to 1.95V supply voltage range.

M69AR048B is a member of STMicroelectronics 1T/1C (one transistor per cell) memory family. These devices are manufactured using dynamic random access memory cells, to minimize the cell size, and maximize the amount of memory that can be implemented in a given area.

However, through the use of internal control logic, the device is fully static in its operation, requiring no external clocks or timing strobes, and has a standard Asynchronous SRAM Interface.

The internal control logic of the M69AR048B handles the periodic refresh cycle, automatically, and without user involvement.

Write cycles can be performed on a single Byte by using Upper Byte Enable (\overline{UB}) and Lower Byte Enable (\overline{LB}).

The device can be put into standby mode using Chip Enable ($\overline{E1}$) or in Power-Down mode by using Chip Enable ($E2$).

The device features several Power-Down modes, making of power saving a user configurable option:

- Partial Power-Down (4 Mbits, 8 Mbits or 16 Mbits) performs a limited refresh of the part of the PSRAM array that contains essential data.
- Deep Power-Down achieves a very low current consumption by halting all the internal activities. Since the refresh circuitry is halted, the duration of the power-down should be less than the maximum period for refresh.

Figure 2. Logic Diagram

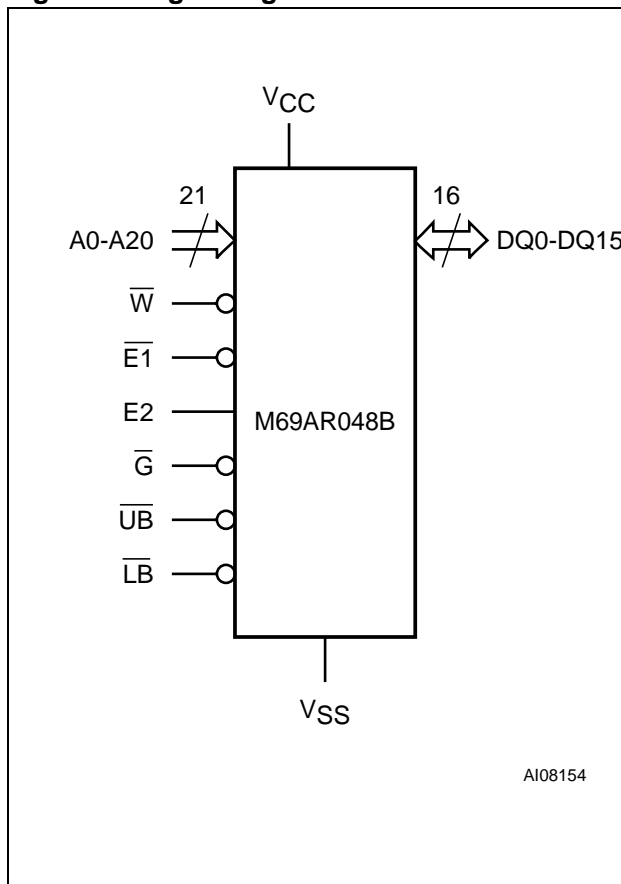
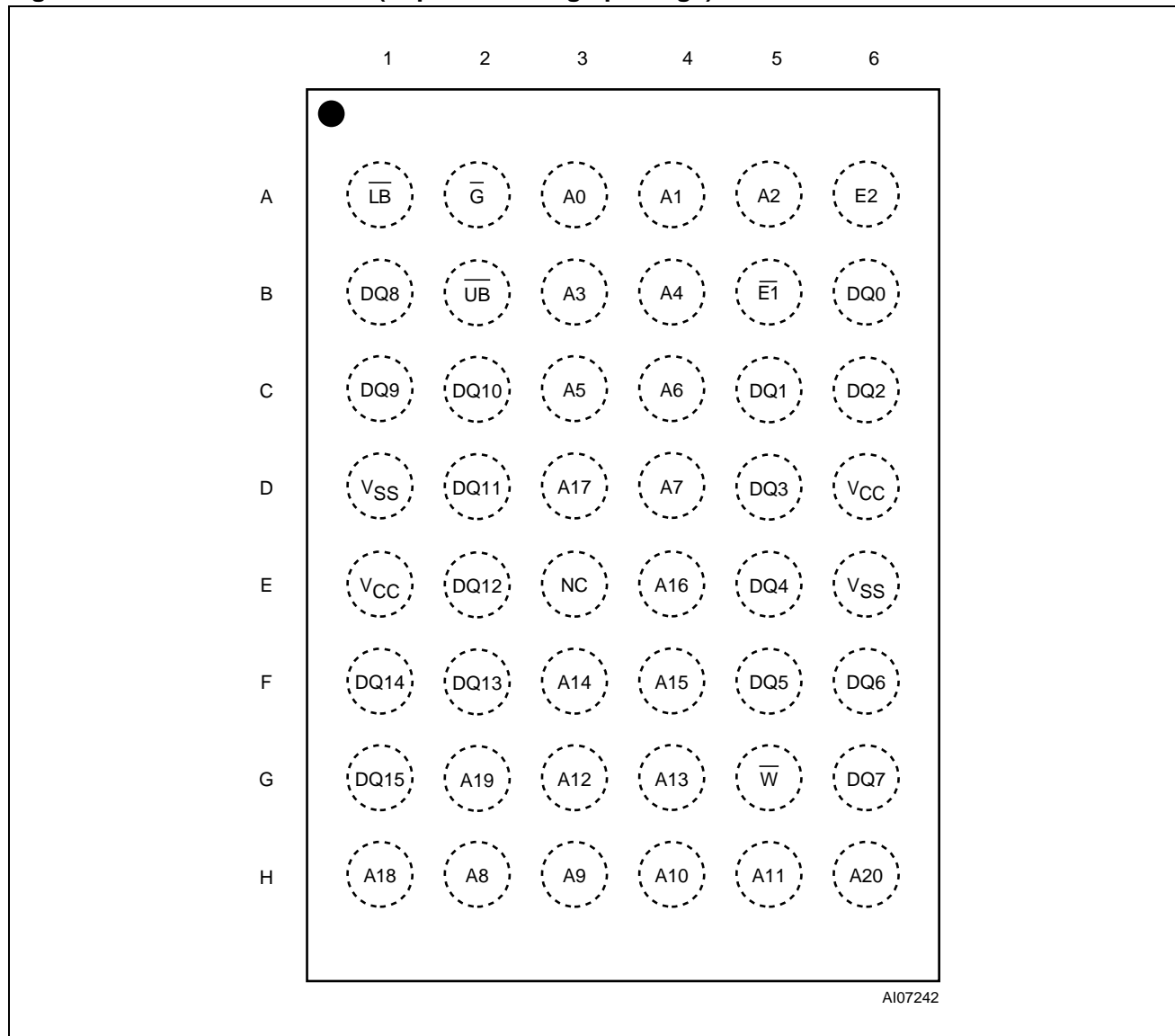

Table 1. Signal Names

| | |
|----------------------|---|
| A0-A20 | Address Input |
| DQ0-DQ15 | Data Input/Output |
| $\overline{E1}$, E2 | Chip Enable, Power-Down |
| \overline{G} | Output Enable |
| \overline{W} | Write Enable |
| \overline{UB} | Upper Byte Enable |
| \overline{LB} | Lower Byte Enable |
| VCC | Supply Voltage |
| VSS | Ground |
| NC | Not Connected (no internal connection) |

Figure 3. TFBGA Connections (Top view through package)



SIGNAL DESCRIPTIONS

See Figure 2, Logic Diagram, and Table 1, Signal Names, for a brief overview of the signals connected to this device.

Address Inputs (A0-A20). The Address Inputs select the cells in the memory array to access during Read and Write operations.

Data Inputs/Outputs (DQ8-DQ15). The Upper Byte Data Inputs/Outputs carry the data to or from the upper part of the selected address during a Write or Read operation, when Upper Byte Enable (\overline{UB}) is driven Low.

Data Inputs/Outputs (DQ0-DQ7). The Lower Byte Data Inputs/Outputs carry the data to or from the lower part of the selected address during a Write or Read operation, when Lower Byte Enable (\overline{LB}) is driven Low.

Chip Enable ($\overline{E1}$). When asserted (Low), the Chip Enable, $\overline{E1}$, activates the memory state machine, address buffers and decoders, allowing Read and Write operations to be performed. When de-asserted (High), all other pins are ignored, and the device is put, automatically, in low-power Standby mode.

Chip Enable (E2). The Chip Enable, E2, puts the device in Power-down mode (Deep Power-Down or a Partial Power-Down mode) when it is driven

Low. Deep Power-down mode is the lowest power mode.

Output Enable (\overline{G}). The Output Enable, \overline{G} , provides a high speed tri-state control, allowing fast read/write cycles to be achieved with the common I/O data bus.

Write Enable (\overline{W}). The Write Enable, \overline{W} , controls the Bus Write operation of the device.

Upper Byte Enable (\overline{UB}). The Upper Byte Enable, \overline{UB} , gates the data on the Upper Byte Data Inputs/Outputs (DQ8-DQ15) to or from the upper part of the selected address during a Write or Read operation.

Lower Byte Enable (\overline{LB}). The Lower Byte Enable, \overline{LB} , gates the data on the Lower Byte Data Inputs/Outputs (DQ0-DQ7) to or from the lower part of the selected address during a Write or Read operation.

V_{CC} Supply Voltage. The V_{CC} Supply Voltage supplies the power for all operations (Read, Write, etc.) and for driving the refresh logic, even when the device is not being accessed.

V_{SS} Ground. The V_{SS} Ground is the reference for all voltage measurements.

Figure 4. Block Diagram

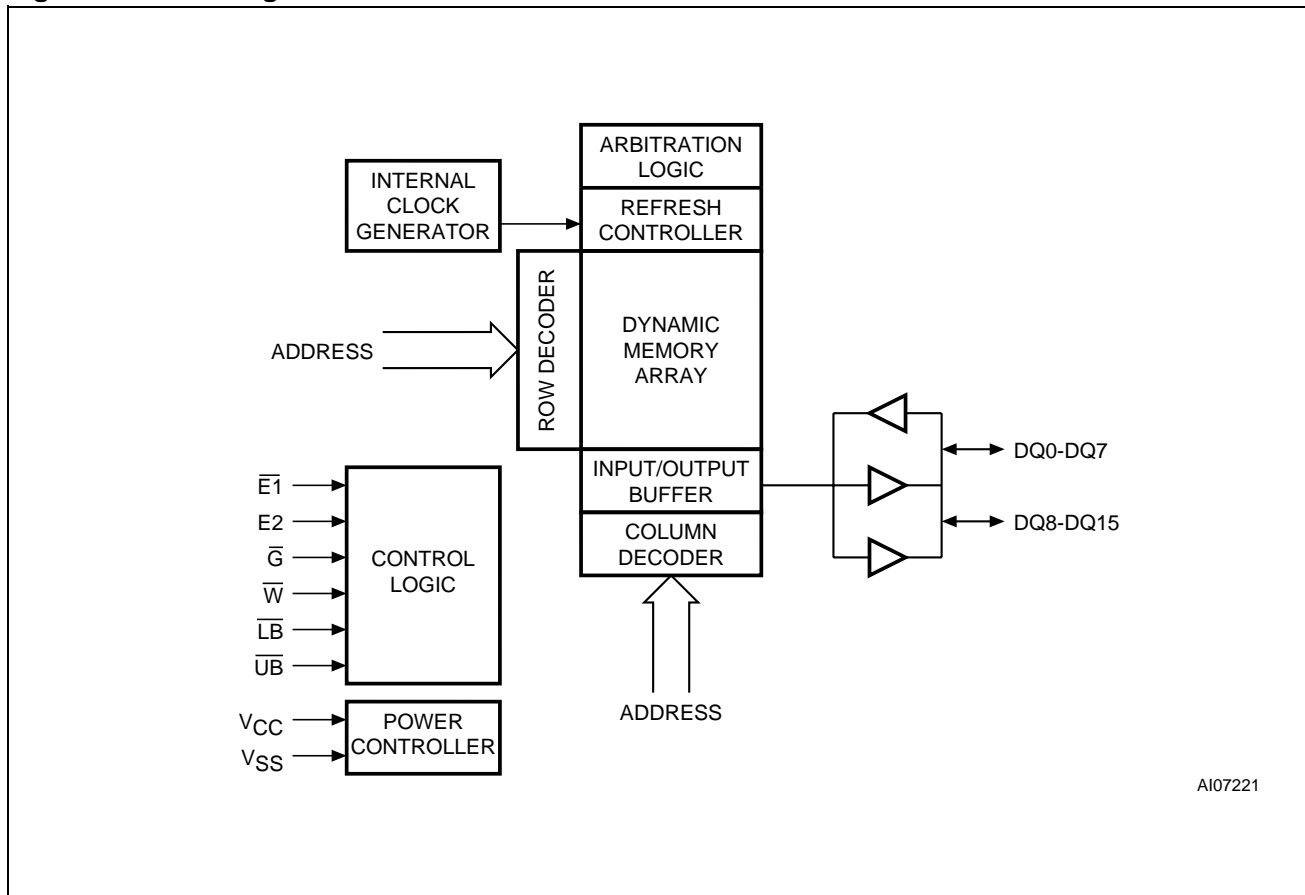

OPERATION

Operational modes are determined by device control inputs \overline{W} , $\overline{E1}$, $E2$, \overline{LB} and \overline{UB} as summarized in the [Operating Modes](#) table (see Table 2).

Power Up Sequence

Because the internal control logic of the M69AR048B needs to be initialized, the following power-up procedure must be followed before the memory is used (see [Figure 25., Power-Up Mode AC Waveforms](#)):

- Apply power and wait for V_{CC} to stabilize
- Wait 300 μ s while driving both Chip Enable signals ($\overline{E1}$ and $E2$) High

Read Mode

The device is in Read mode when:

- Write Enable (\overline{W}) is High and
- Output Enable (\overline{G}) is Low and
- the two Chip Enable signals are asserted ($\overline{E1}$ is Low, and $E2$ is High).

The time taken to enter Read mode (t_{ELQV} , t_{GLQV} or t_{BLQV}) depends on which of the above signals was the last to reach the appropriate level.

Data out (DQ15-DQ0) may be indeterminate during t_{ELQX} , t_{GLQX} and t_{BLQX} , but data will always be valid during t_{AVQV} . See [Figures 8, 9, 10, 11 and 12](#) and [Table 11., Read Mode AC Characteristics](#), for details of when the outputs become valid.

Write Mode

The device is in Write mode when

- Write Enable (\overline{W}) is Low and
- at least one of Upper Byte Enable (\overline{UB}) and Lower Byte Enable (\overline{LB}) is Low
- the two Chip Enable signals are asserted ($E1$ is Low, and $E2$ is High).

The Write cycle begins just after the event (the falling edge) that causes the last of these conditions to become true (t_{AVWL} or t_{AVEL} or t_{AVBL}).

The Write cycle is terminated by the rising edge of Write Enable (\overline{W}) or Chip Enable ($\overline{E1}$), whichever occurs first.

If the device is in Write mode (Chip Enable ($\overline{E1}$) is Low, Output Enable (\overline{G}) is Low, Upper Byte Enable (\overline{UB}) and/or Lower Byte Enable (\overline{LB}) is Low), then Write Enable (\overline{W}) will return the outputs to high impedance within t_{WHDZ} of its rising edge. Care must be taken to avoid bus contention in this type of operation. Data input must be valid for t_{D-VWH} before the rising edge of Write Enable (\overline{W}), or for t_{DVEH} before the rising edge of Chip Enable ($\overline{E1}$), whichever occurs first, and remain valid for t_{WHDZ} , t_{BHDZ} or t_{EHDZ} .

See [Figures 13, 14, 15, 16, 17 and 18](#), and [Table 12., Write Mode AC Characteristics](#), for details of

the timing requirements. [Figures 19, 20, 21 and 22](#) show Read and Write mode AC waveforms.

Standby Mode

The device is in Standby mode when:

- Chip Enable ($\overline{E1}$) is High and
- Chip Enable ($E2$) is High

The input/output buffers and the decoding/control logic are switched off, but the dynamic array continues to be refreshed. In this mode, the memory current consumption, I_{SB} , is reduced, and the data remains valid.

See [Figure 26., Standby Mode Entry AC Waveforms, After Read](#) and [Table 13., Standby Mode AC Characteristics](#) for details.

Power-Down Modes

Description. The M69AR048B has four Power-down modes, Deep Power-down, 4Mbit Partial Power-Down, 8Mbit Partial Power-Down, and 16Mbit Partial Power-Down (see Table 3).

These can be entered using a series of read and write operations. Each mode has the following features. The default state is Deep Power-Down and it is the lowest power consumption but all data will be lost once $E2$ is brought Low for Power-down. No sequence is required to put the device in Deep Power-down mode after Power-up.

The device is in one of the Power-Down modes when:

- Chip Enable ($E2$) is Low

All the device logic is switched off and all internal operations are suspended. This gives the lowest power consumption. In this operating mode, no refresh is performed, and data is lost if the duration is longer than 10ns. This mode is useful for those applications where the data contents are no longer needed, and can be lost, but where reduced current consumption is of major importance.

See [Figure 24., Power-Down Mode AC Waveforms](#) and [Table 13., Standby Mode AC Characteristics](#) for details.

Power-Down Program Sequence. The Power-Down Program sequence is used to program the Power-Down Configuration. It requires a total of six read and write operations, with specific addresses and data. Between each read or write operation the device must be in Standby mode.

[Table 4](#) and [Figure 23.](#) show the sequence. In the first cycle, the Byte at the highest memory address (MSB) is read. In the second and third cycles, the data (RDa) read by first cycle are written back. If the third cycle is written into a different address, the sequence is aborted, and the data written by the third cycle is valid as in a normal write operation. In the fourth and fifth cycles, the Power-Down Config-

uration data is written. The data of the fourth cycle must be all 0s, and the data of the fifth cycle is the Power-Down Configuration data (see Table 5., Power-Down Configuration Data). If the fourth cycle is written into a different address, the sequence is aborted. In the last cycle, a read is made from the specific Power-Down Configuration address (see Table 6., Power-Down Configuration Addresses). The Power-Down Configuration data

and address must correspond, otherwise the sequence is aborted.

When this sequence is performed to take the device from one Partial Power-Down mode to another, the write data may be lost. So, if a Partial Power-Down mode is used, this sequence should be performed prior to any normal read or write operations.

Table 2. Operating Modes

| Operation | $\overline{E1}$ | E2 | \overline{W} | \overline{G} | \overline{LB} | \overline{UB} | DQ0-DQ7 | DQ8-DQ15 | Power |
|---------------------------------|-----------------|-----------------|-----------------|--------------------------------|-----------------|-----------------|-------------|-------------|---|
| Standby (Deselected) | V _{IH} | V _{IH} | X | X | X | X | Hi-Z | Hi-Z | Standby (I _{SB}) |
| Power-down ⁽²⁾ | X | V _{IL} | X | X | X | X | Hi-Z | Hi-Z | Power-Down (I _{CCPD} , I _{CCP4} , I _{CCP8} or I _{CCP16}) |
| No Read ⁽¹⁾ | V _{IL} | V _{IH} | V _{IH} | V _{IL} | V _{IH} | V _{IH} | Hi-Z | Hi-Z | Output Disable |
| Lower Byte Read ⁽¹⁾ | V _{IL} | V _{IH} | V _{IH} | V _{IL} | V _{IL} | V _{IH} | Data Output | Hi-Z | Active (I _{CC}) |
| Lower Byte Write ⁽¹⁾ | V _{IL} | V _{IH} | V _{IL} | V _{IH} | V _{IL} | V _{IH} | Data Input | Hi-Z | Active (I _{CC}) |
| No Write | V _{IL} | V _{IH} | V _{IL} | V _{IH} | V _{IH} | V _{IH} | Hi-Z | Hi-Z | Output Disable |
| Upper Byte Read ⁽¹⁾ | V _{IL} | V _{IH} | V _{IH} | V _{IL} | V _{IH} | V _{IL} | Hi-Z | Data Output | Active (I _{CC}) |
| Upper Byte Write ⁽¹⁾ | V _{IL} | V _{IH} | V _{IL} | V _{IH} | V _{IH} | V _{IL} | Hi-Z | Data Input | Active (I _{CC}) |
| Word Read ⁽¹⁾ | V _{IL} | V _{IH} | V _{IH} | V _{IL} | V _{IL} | V _{IL} | Data Output | Data Output | Active (I _{CC}) |
| Word Write ⁽¹⁾ | V _{IL} | V _{IH} | V _{IL} | V _{IH} ⁽³⁾ | V _{IL} | V _{IL} | Data Input | Data Input | Active (I _{CC}) |

Note: X = V_{IH} or V_{IL}.

1. Should not be kept in this logic condition for a period longer than 1 μs.
2. Power-Down mode can be entered from Standby state and all DQ pins are in High-Z state. The Power-Down current and data retention depend on the selection of the Power-Down programming.
3. \overline{G} can be V_{IL} during the Write operation if the following conditions are satisfied:
 - a. Write pulse is initiated by $\overline{E1}$ ($\overline{E1}$ Controlled Write timing), or cycle time of the previous operation cycle is satisfied;
 - b. \overline{G} stays V_{IL} during the entire Write cycle.

Table 3. Power-Down Modes

| Mode | Data Retention | Retention Address |
|---------------------------|----------------|-------------------|
| Deep Power-Down (default) | No | N/A |
| 4M Partial Power-Down | 4 Mbit | 00000h – 3FFFFh |
| 8M Partial Power-Down | 8 Mbit | 00000h – 7FFFFh |
| 16M Partial Power-Down | 16 Mbit | 00000h – FFFFFh |

Table 4. Power-Down Program Sequence

| Cycle # | Operation | Address | Data |
|---------|-----------|----------------------------|-------------------------|
| 1st | Read | 1FFFFFFh (MSB) | Read Data (RDa) |
| 2nd | Write | 1FFFFFFh | RDa |
| 3rd | Write | 1FFFFFFh | RDa |
| 4th | Write | 1FFFFFFh | 0000h |
| 5th | Write | 1FFFFFFh | PDC Data ⁽¹⁾ |
| 6th | Read | PDC Address ⁽¹⁾ | Read Data (RDb) |

Note: 1. PDC Power-Down Configuration.

Table 5. Power-Down Configuration Data

| Mode | Power-Down Configuration Data | | | |
|---------------------------|-------------------------------|---------|-----|-----|
| | DQ15–DQ9 | DQ8–DQ2 | DQ1 | DQ0 |
| Deep Power-Down (default) | 0 | 0 | 1 | 1 |
| 4Mb Partial Power-Down | 0 | 0 | 1 | 0 |
| 8Mb Partial Power-Down | 0 | 0 | 0 | 1 |
| 16Mb Partial Power-Down | 0 | 0 | 0 | 0 |

Table 6. Power-Down Configuration Addresses

| Mode | Power-Down Configuration Addresses | | | |
|---------------------------|------------------------------------|-----|--------|-----------|
| | A20 | A19 | A18–A0 | Binary |
| Deep Power-Down (default) | 1 | 1 | 1 | 1FFFFFFh |
| 4Mb Partial Power-Down | 0 | 1 | 1 | 0FFFFFFh |
| 8Mb Partial Power-Down | 1 | 0 | 1 | 17FFFFFFh |
| 16Mb Partial Power-Down | 0 | 0 | 1 | 07FFFFFFh |

MAXIMUM RATING

Stressing the device above the rating listed in the Absolute Maximum Ratings table may cause permanent damage to the device. Exposure to Absolute Maximum Rating conditions for extended periods may affect device reliability. These are stress ratings only and operation of the device at

these or any other conditions above those indicated in the Operating sections of this specification is not implied. Refer also to the STMicroelectronics SURE Program and other relevant quality documents.

Table 7. Absolute Maximum Ratings

| Symbol | Parameter | Min | Max | Unit |
|-----------|-------------------------------|------|-----|------|
| I_O | Output Current | -50 | 50 | mA |
| T_A | Ambient Operating Temperature | -30 | 85 | °C |
| T_{STG} | Storage Temperature | -55 | 125 | °C |
| V_{CC} | Core Supply Voltage | -0.5 | 3.6 | V |
| V_{IO} | Input or Output Voltage | -0.5 | 3.6 | V |

DC AND AC PARAMETERS

This section summarizes the operating measurement conditions, and the DC and AC characteristics of the device. The parameters in the DC and AC characteristics Tables that follow, are derived from tests performed under the Measurement

Conditions summarized in Table 8, Operating and AC Measurement Conditions. Designers should check that the operating conditions in their circuit match the operating conditions when relying on the quoted parameters.

Table 8. Operating and AC Measurement Conditions

| Parameter | M69AR048B | | | | Unit |
|--|--|-----------------|--|-----------------|------|
| | 70 | | 80, 85 | | |
| | Min | Max | Min | Max | |
| V _{CC} Supply Voltage ¹ | 1.75 | 1.95 | 1.65 | 1.95 | V |
| Ambient Operating Temperature | -30 | 85 | -30 | 85 | °C |
| Load Capacitance (C _L) | 50 | | 50 | | pF |
| Input Pulse Voltages | 0 | V _{CC} | 0 | V _{CC} | V |
| Input and Output Timing Ref. Voltages | V _{CC} /2 | | V _{CC} /2 | | V |
| Output Transition Timing Ref. Voltages | V _{RL} = 0.3V _{CC} ; V _{RH} = 0.7V _{CC} | | V _{RL} = 0.3V _{CC} ; V _{RH} = 0.7V _{CC} | | V |
| Input Transition Time ² (τ) between V _{IL} and V _{IH} | 5 | | 5 | | ns |

Note: 1. All voltages are referenced to V_{SS}.

2. The Input Transition Time used in AC measurements is 5ns. For other input transition times, see Table 8.

Figure 5. AC Measurement Load Circuit 1

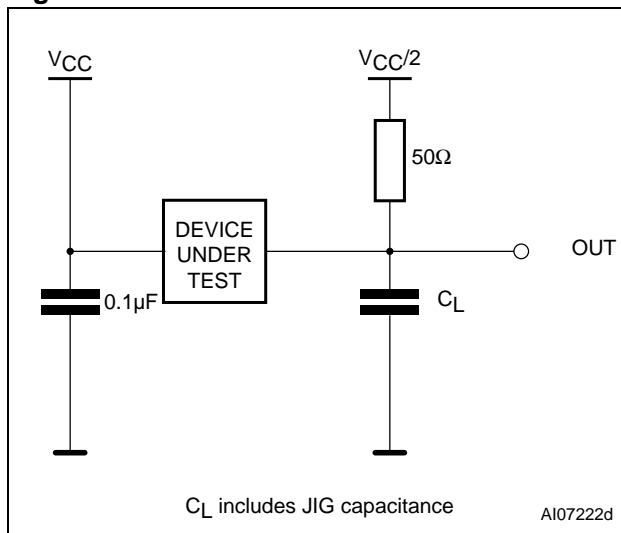

Figure 6. AC Measurement Load Circuit 2

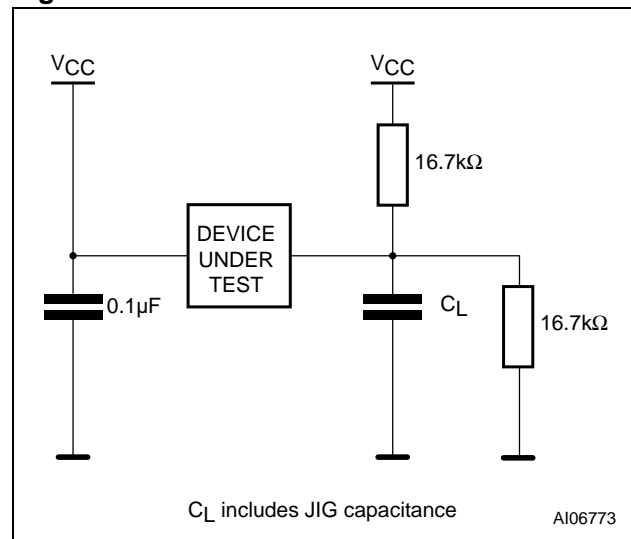

Table 9. Capacitance

| Symbol | Parameter | Test Condition | Min | Max | Unit |
|------------------|---|-----------------------|-----|-----|------|
| C _{IN} | Input Capacitance on all pins (except DQ) | V _{IN} = 0V | | 5 | pF |
| C _{OUT} | Output Capacitance | V _{OUT} = 0V | | 8 | pF |

Figure 7. AC Measurement I/O Waveform

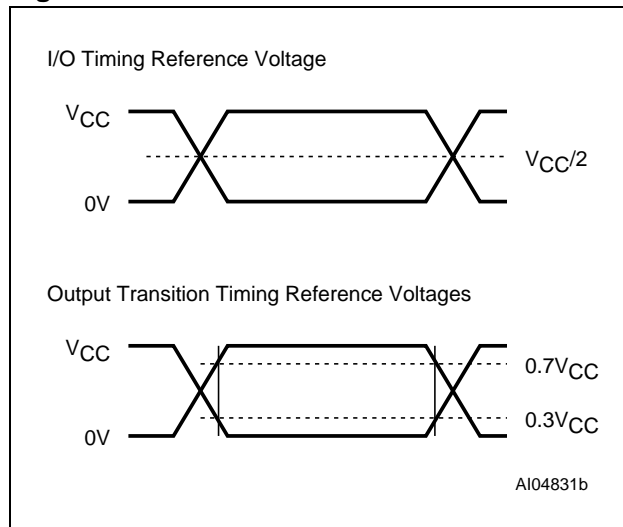

Table 10. DC Characteristics

| Symbol | Parameter | Test Condition | Min | Max | Unit | |
|--------------------------------|------------------------------------|--|--|-----------------------|------|----|
| I _{CC1} | V _{CC} Active Current | V _{CC} = 1.95V, V _{IN} = V _{IH} or V _{IL} , E1 = V _{IL} and E2 = V _{IH} , I _{OUT} = 0mA | t _{RC} / t _{wC} = minimum | | 25 | mA |
| I _{CC2} | | | t _{RC} / t _{wC} = 1 μs | | 3 | mA |
| I _{CC3} | V _{CC} Page Read Current | V _{CC} = 1.95V, V _{IN} = V _{IH} or V _{IL} , E1 = V _{IL} and E2 = V _{IH} , I _{OUT} = 0mA, t _{PRC} = min. | | | 10 | mA |
| I _{CCPD} | V _{CC} Power-Down Current | V _{CC} = 1.95V, V _{IN} = V _{IH} or V _{IL} , E2 ≤ 0.2V | Deep Power-Down | | 10 | μA |
| I _{CCP4} | | | 4Mb Partial ⁽³⁾ | | 40 | μA |
| I _{CCP8} | | | 8Mb Partial ⁽³⁾ | | 50 | μA |
| I _{CCP16} | | | 16Mb Partial ⁽³⁾ | | 65 | μA |
| I _{LI} | Input Leakage Current | 0V ≤ V _{IN} ≤ V _{CC} | -1 | 1 | μA | |
| I _{LO} | Output Leakage Current | 0V ≤ V _{OUT} ≤ V _{CC} | -1 | 1 | μA | |
| I _{SB} | Standby Supply Current CMOS | V _{CC} = 1.95V, V _{IN} ≤ 0.2V or V _{IN} ≥ V _{CC} - 0.2V, E1 = E2 ≥ V _{CC} - 0.2V | | | 100 | μA |
| V _{IH} ⁽¹⁾ | Input High Voltage | | 0.8V _{CC} | V _{CC} + 0.2 | V | |
| V _{IL} ⁽²⁾ | Input Low Voltage | | -0.3 | 0.2V _{CC} | V | |
| V _{OH} | Output High Voltage | V _{CC} = 1.65V, I _{OH} = -0.5mA | 1.4 | | V | |
| V _{OL} | Output Low Voltage | I _{OL} = 1mA | | 0.4 | V | |

Note: 1. Maximum DC voltage on input and I/O pins is V_{CC} + 0.2V.
During voltage transitions, input may overshoot to V_{CC} + 1.0V for a period of up to 5ns.
2. Minimum DC voltage on input or I/O pins is -0.3V.
During voltage transitions, input may undershoot to V_{SS} - 1.0V for a period of up to 5ns.
3. Partial stands for Partial Power-Down.

Table 11. Read Mode AC Characteristics

| Symbol | Alt. | Parameter | M69AR048B | | | | Unit |
|-------------------------|------------|---|--------------------------------|------|-----|------|------|
| | | | 80 | | 85 | | |
| | | | Min | Max | Min | Max | |
| $t_{AVAX}^{(1,2,9)}$ | t_{RC} | Address Valid Time | 80 | 1000 | 85 | 1000 | ns |
| $t_{AVAX2}^{(1,5,6,9)}$ | t_{PRC} | Page Read Cycle Time | 25 | 1000 | 30 | 1000 | ns |
| $t_{AVEH2}^{(1,5,6,9)}$ | t_{PRC} | Page Read Cycle Time | 25 | 1000 | 30 | 1000 | ns |
| t_{AVEL} | t_{ASC} | Address Valid to Chip Enable Low | -5 | | -5 | | ns |
| $t_{AVQV}^{(4,9)}$ | t_{AA} | Address Valid to Output Valid | $1.65V \leq V_{CC} \leq 1.75V$ | 80 | | 85 | ns |
| | | | $1.75V \leq V_{CC} \leq 1.95V$ | 70 | | 70 | ns |
| $t_{AVQV2}^{(5,9)}$ | t_{PAA} | Page Address Access Time | | 20 | | 25 | ns |
| $t_{AXAV}^{(4,7)}$ | t_{AX} | Address Invalid Time | | 10 | | 10 | ns |
| $t_{AXAV2}^{(5,7)}$ | t_{AXP} | Page Address Invalid Time | | 10 | | 10 | ns |
| t_{AXQX} | t_{OH} | Data hold from address change | 5 | | 5 | | ns |
| t_{BHQX} | t_{OH} | Upper/Lower Byte Enable High to Output Transition | 5 | | 5 | | ns |
| t_{BHQZ} | t_{BHZ} | Upper/Lower Byte Enable High to Output Hi-Z | | 20 | | 20 | ns |
| $t_{BLQV}^{(9)}$ | t_{BA} | Upper/Lower Byte Enable Low to Output Valid | | 30 | | 35 | ns |
| $t_{BLQX}^{(3)}$ | t_{BLZ} | Upper/Lower Byte Enable Low to Output Transition | 0 | | 0 | | ns |
| $t_{EHAX}^{(8)}$ | t_{CHAH} | Chip Enable High to Address Invalid | -5 | | -5 | | ns |
| t_{EHEL} | t_{CP} | Chip Enable High to Chip Enable Low | 15 | | 15 | | ns |
| t_{EHQX} | t_{OH} | Chip Enable High to Output Transition | 5 | | 5 | | ns |
| t_{EHQZ} | t_{CHZ} | Chip Enable High to Output Hi-Z | | 20 | | 20 | ns |
| $t_{ELAX}^{(1,2)}$ | t_{RC} | Read Cycle Time | 80 | 1000 | 85 | 1000 | ns |
| $t_{ELEH}^{(1,2)}$ | t_{RC} | Read Cycle Time | 80 | 1000 | 85 | 1000 | ns |
| $t_{ELQV}^{(9)}$ | t_{CE} | Chip Enable Low to Output Valid | $1.65V \leq V_{CC} \leq 1.75V$ | 80 | | 85 | ns |
| | | | $1.75V \leq V_{CC} \leq 1.95V$ | 70 | | 70 | |
| $t_{ELQX}^{(3)}$ | t_{CLZ} | Chip Enable Low to Output Transition | 5 | | 5 | | ns |
| t_{GHQX} | t_{OH} | Output Data Hold Time | 5 | | 5 | | ns |
| t_{GHQZ} | t_{OHZ} | Output Enable High to Output Hi-Z | | 20 | | 20 | ns |
| $t_{GLQV}^{(9)}$ | t_{OE} | Output Enable Low to Output Valid | | 45 | | 50 | ns |
| $t_{GLQX}^{(3)}$ | t_{OLZ} | Output Enable Low to Output Transition | 0 | | 0 | | ns |

- Note: 1. Maximum value is applicable if $\overline{E1}$ is kept Low without change of address input of A3 to A20. If needed by system operation, please contact your local ST representative for relaxation of the 1000ns limitation.
2. Address should not be changed within minimum Read Cycle Time.
3. The output load 5pF without any other load.
4. Applicable to A3 to A20 when $\overline{E1}$ is kept Low.
5. Applicable only to A0, A1 and A2 when $\overline{E1}$ is kept Low for the page address access.
6. In case Page Read Cycle is continued with keeping $\overline{E1}$ stays Low, $\overline{E1}$ must be brought to High within 4 μ s. In other words, Page Read Cycle must be closed within 4 μ s.
7. Applicable when at least two of address inputs among applicable are switched from previous state.
8. Minimum Read Cycle Time and minimum Page Read Cycle Time must be satisfied.
9. Values obtained with AC Measurement Load Circuit 1 (see Figure 5). If the test conditions correspond to AC Measurement Load Circuit 2 (see Figure 6), 10ns must be added to the times given in the above table.

Figure 8. Address Controlled, Read Mode AC Waveforms

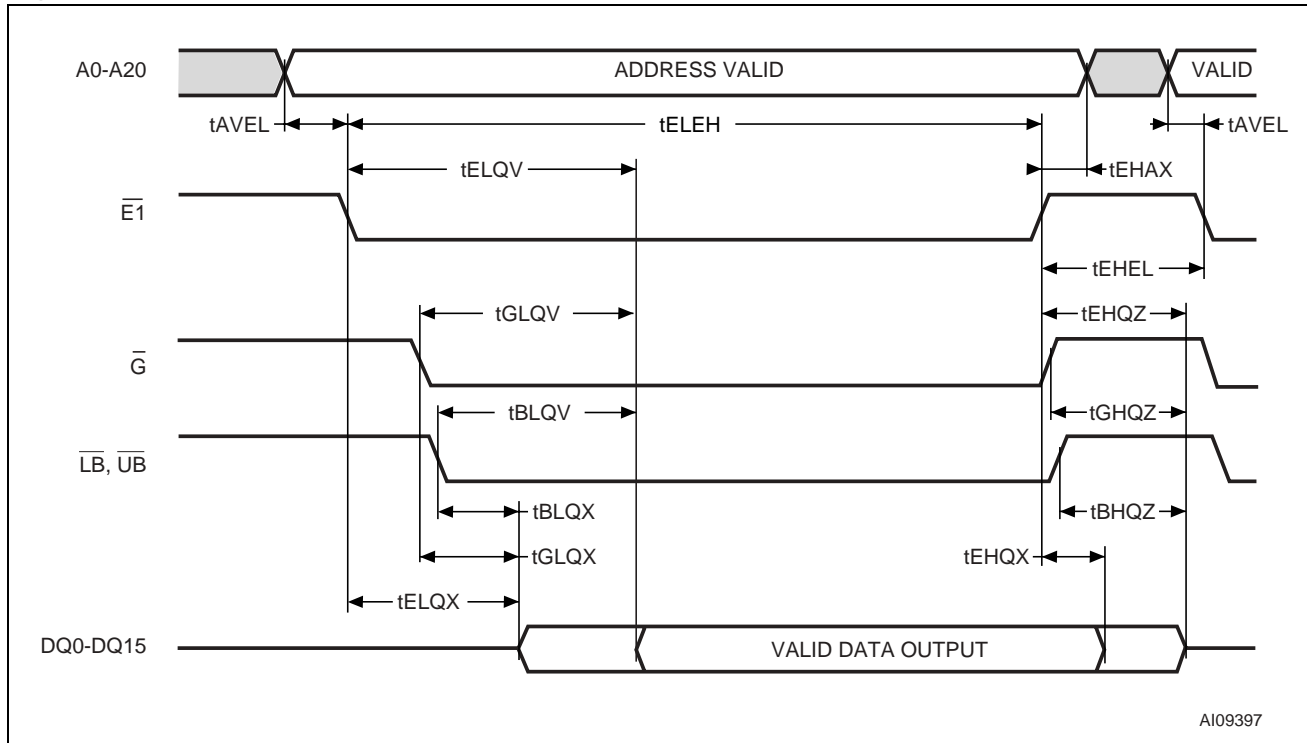

Note: E2 = High, W-bar = High.

Figure 9. Address and Output Enable Controlled, Read Mode AC Waveforms

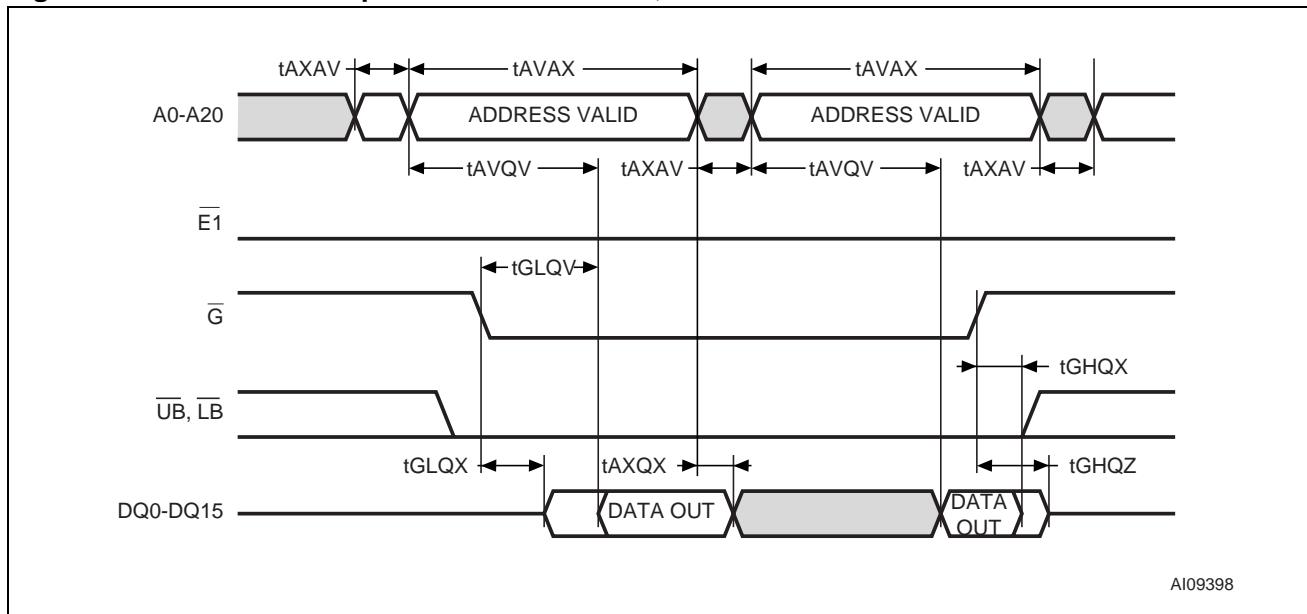

Note: Write Enable (W-bar) = High, E2 = High.

Figure 10. $\overline{UB}/\overline{LB}$ Controlled, Read Mode AC Waveforms

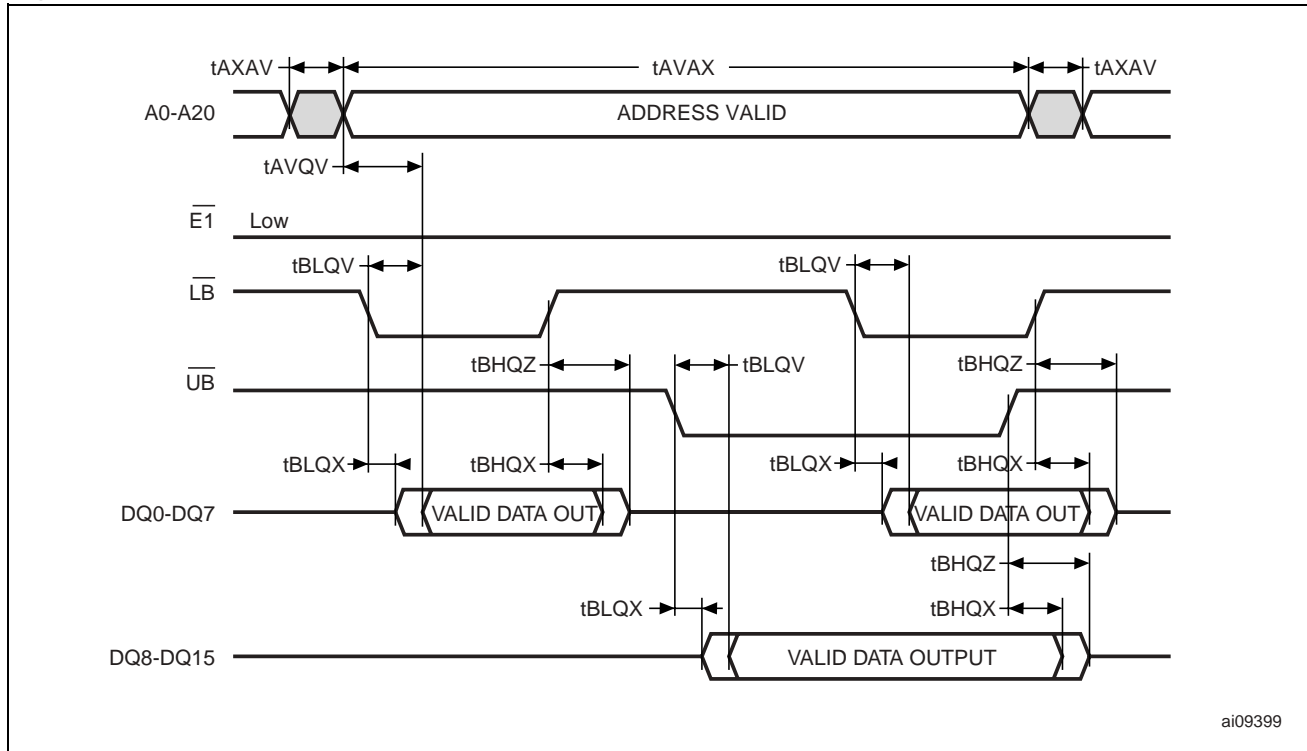

ai09399

Note: E2 = High, \overline{G} = Low, \overline{W} = High.

Figure 11. Page Address and Chip Enable Controlled, Read Mode AC Waveforms

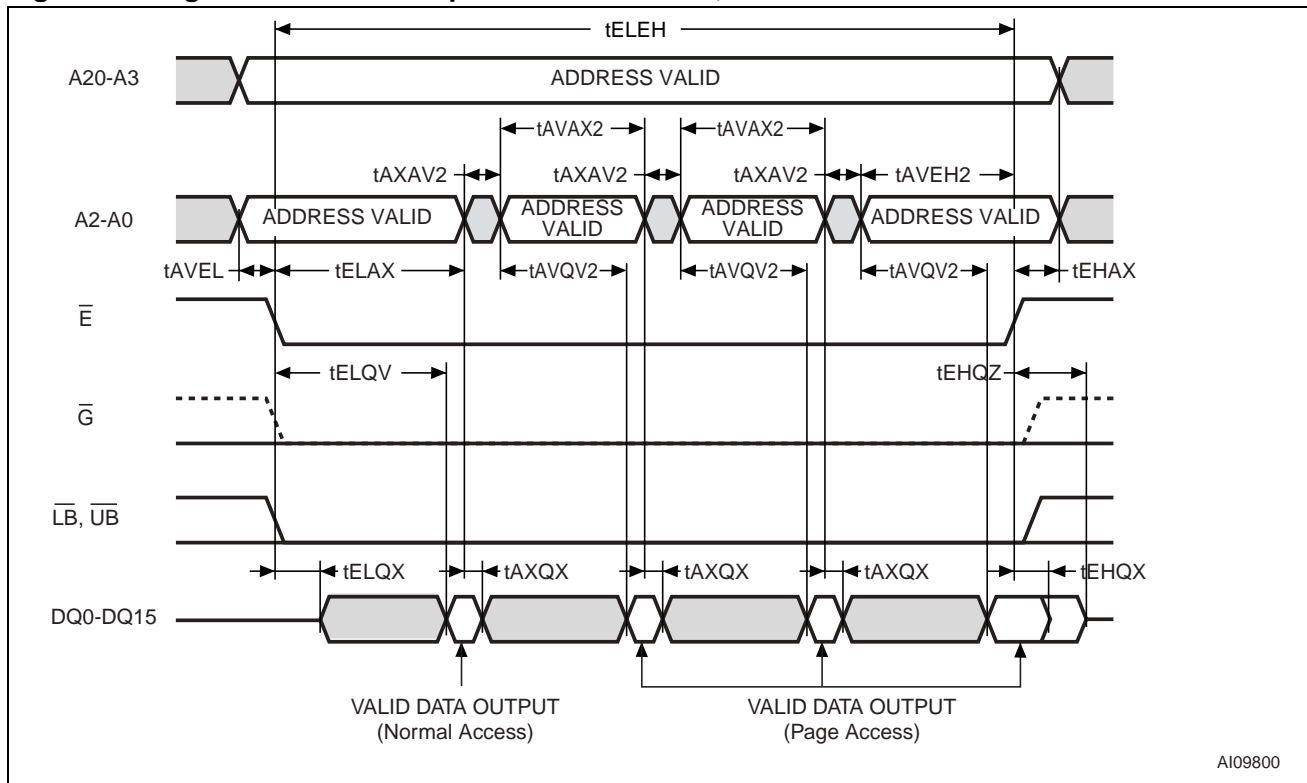

AI09800

Note: Write Enable (\overline{W}) = High, E2 = High.

Figure 12. Random and Page Address Controlled, Read Mode AC Waveforms

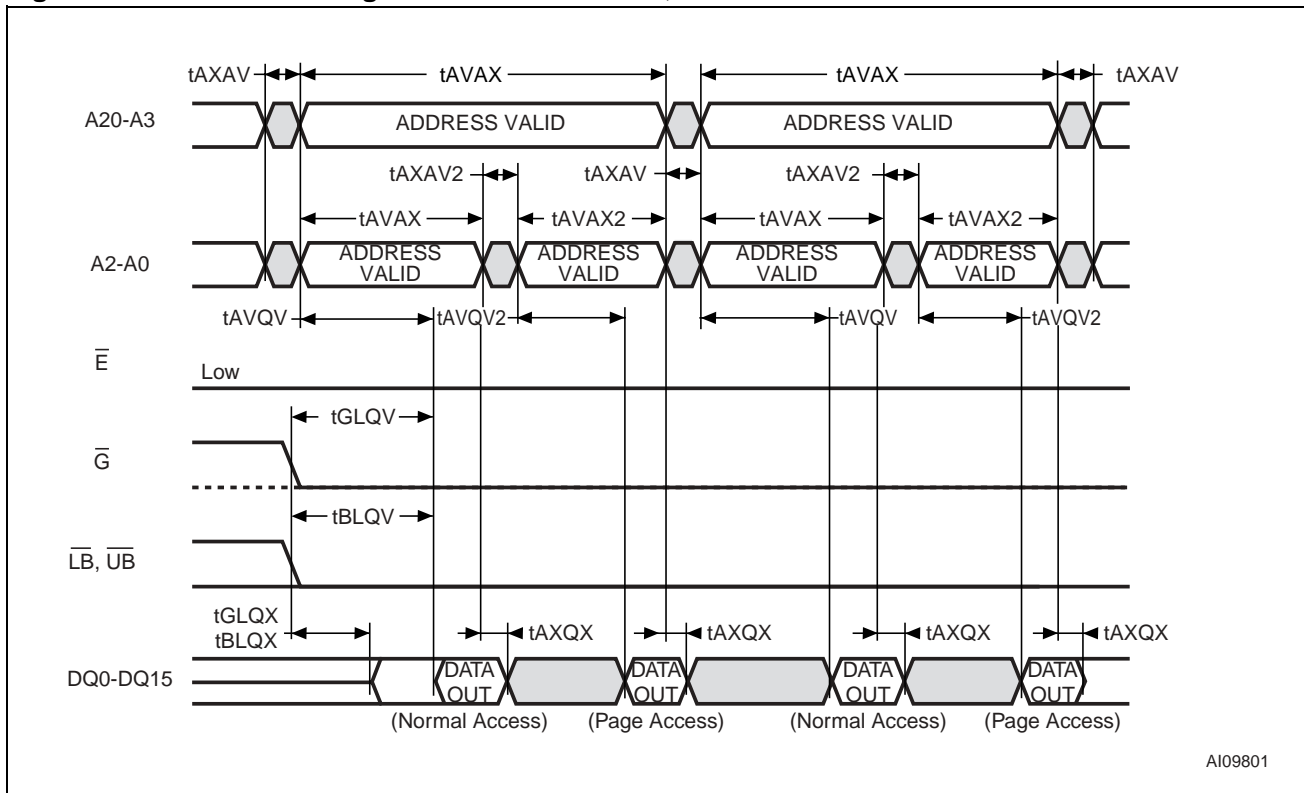

Note: E2 = High.

Table 12. Write Mode AC Characteristics

| Symbol | Alt. | Parameter | M69AR048B | | | | Unit |
|--------------------|-------|---|-----------|------|-----|------|------|
| | | | 80 | | 85 | | |
| | | | Min | Max | Min | Max | |
| $t_{AVAX}^{(1,2)}$ | tWC | Write Cycle Time | 80 | 1000 | 85 | 1000 | ns |
| $t_{AVBL}^{(2)}$ | tAS | Address Valid to \overline{LB} , \overline{UB} Low | 0 | | 0 | | ns |
| $t_{AVEL}^{(2)}$ | tAS | Address Valid to Chip Enable Low | 0 | | 0 | | ns |
| $t_{AVWL}^{(2)}$ | tAS | Address Valid to Write Enable Low | 0 | | 0 | | ns |
| $t_{AXAV}^{(5)}$ | tAXW | Address Invalid Time for Write | | 10 | | 10 | ns |
| $t_{BHAX}^{(4)}$ | tBR | \overline{LB} , \overline{UB} High to Address Transition | 15 | 1000 | 15 | 1000 | ns |
| t_{BHDZ} | tDH | \overline{LB} , \overline{UB} High to Input High-Z | 0 | | 0 | | ns |
| $t_{BLBH}^{(3)}$ | tBW | \overline{LB} , \overline{UB} Low to \overline{LB} , \overline{UB} High | 45 | | 50 | | ns |
| t_{BLBH2} | tBWO | \overline{LB} , \overline{UB} Low to \overline{LB} , \overline{UB} High for Page Access | 20 | | 20 | | ns |
| $t_{BLWH}^{(3)}$ | tBW | \overline{LB} , \overline{UB} Low to Write Enable High | 45 | | 50 | | ns |
| t_{DVBH} | tDS | Input Valid to \overline{LB} , \overline{UB} High | 20 | | 20 | | ns |
| t_{DVEH} | tDS | Input Valid to Chip Enable High | 20 | | 20 | | ns |
| t_{DVWH} | tDS | Input Valid to Write Enable High | 20 | | 20 | | ns |
| $t_{EHAX}^{(4)}$ | tWRC | Chip Enable High to Address Transition | 15 | | 15 | | ns |
| t_{EHDZ} | tDH | Chip Enable High to Input High-Z | 0 | | 0 | | ns |
| t_{EHEL} | tCP | Chip Enable High to Chip Enable Low | 15 | | 15 | | ns |
| $t_{ELAX}^{(1,2)}$ | tWC | Write Cycle Time | 80 | 1000 | 85 | 1000 | ns |
| $t_{ELEH}^{(3)}$ | tCW | Chip Enable Low to Chip Enable High | 45 | | 50 | | ns |
| $t_{GHAV}^{(7)}$ | tOES | Output Enable High to Address Valid | 0 | | 0 | | ns |
| $t_{GHEL}^{(6)}$ | tOHCL | Output Enable High to Chip Enable Low | -5 | | -5 | | ns |
| $t_{WHAX}^{(4)}$ | tWR | Write Enable High to Address Transition | 15 | 1000 | 15 | 1000 | ns |
| t_{WHDZ} | tDH | Write Enable High to Input High-Z | 0 | | 0 | | ns |
| $t_{WLBH}^{(3)}$ | tWP | Write Enable Low to \overline{LB} , \overline{UB} High | 45 | | 50 | | ns |
| $t_{WLWH}^{(3)}$ | tWP | Write Enable Low to Write Enable High | 45 | | 50 | | ns |

Note: 1. Maximum value is applicable if $\overline{E1}$ is kept Low without any address change. If needed by system operation, please contact your local ST representative for relaxation of the 1000ns limitation.

2. Minimum value must be equal to or greater than the sum of write pulse (tCW, tWP or tBW) and write recovery time (tWRC, tWR or tBR).

3. Write pulse is defined from the falling edge of $\overline{E1}$, \overline{W} , or $\overline{LB}/\overline{UB}$, whichever occurs last.

4. Write recovery is defined from Write pulse is defined from the rising edge of $\overline{E1}$, \overline{W} , or $\overline{LB}/\overline{UB}$, whichever occurs first.

5. Applicable to any address change when $\overline{E1}$ stays Low.

6. If \overline{G} is Low after minimum tGHEL, the read cycle is initiated. In other words, \overline{G} must be brought High within 5ns after $\overline{E1}$ is brought Low. Once the read cycle is initiated, new write pulse should be input after minimum Read Cycle Time is met.

7. If \overline{G} is Low after new address input, the read cycle is initiated. In other words, \overline{G} must be brought High at the same time or before new address valid. Once the read cycle is initiated, new write pulse should be input after minimum Read Cycle Time is met.

Figure 13. Chip Enable Controlled, Write AC Waveforms

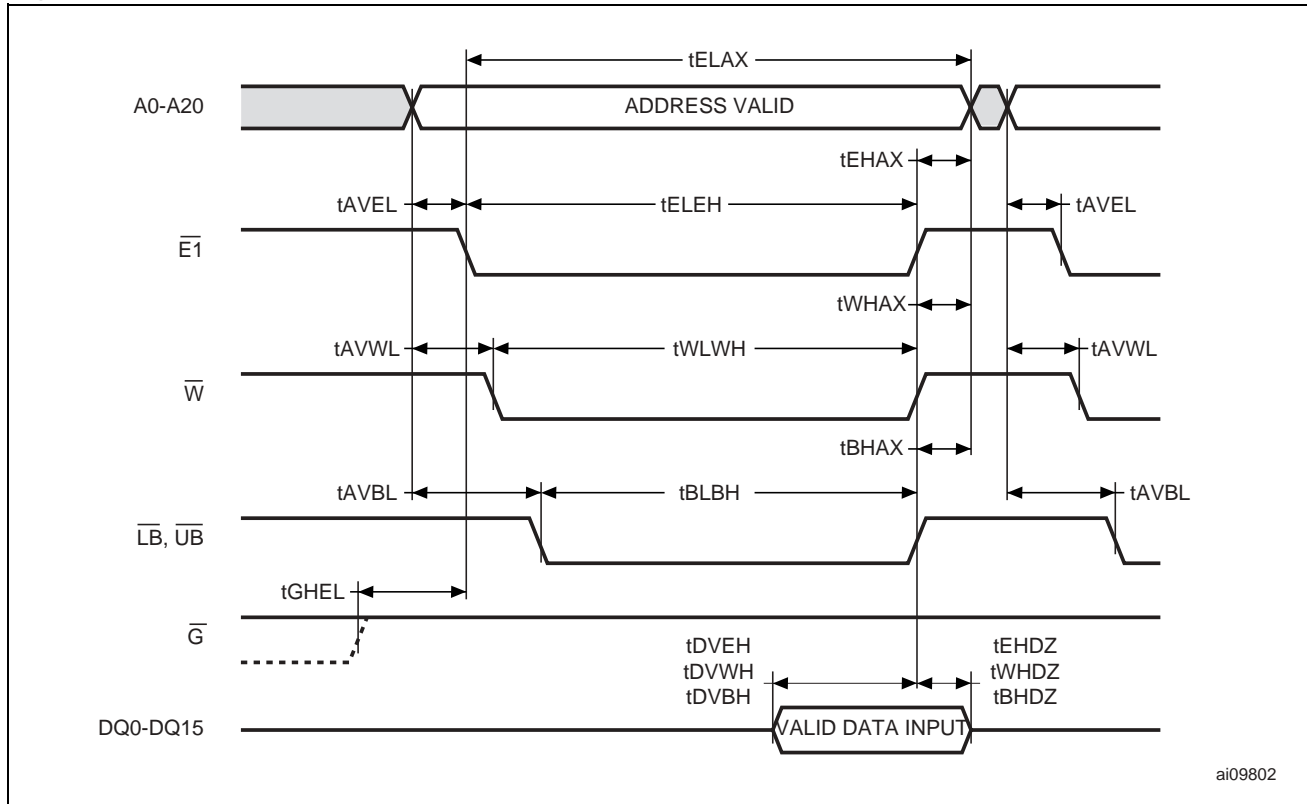

Note: E2 = High.

Figure 14. Write Enable Controlled, Write AC Waveforms

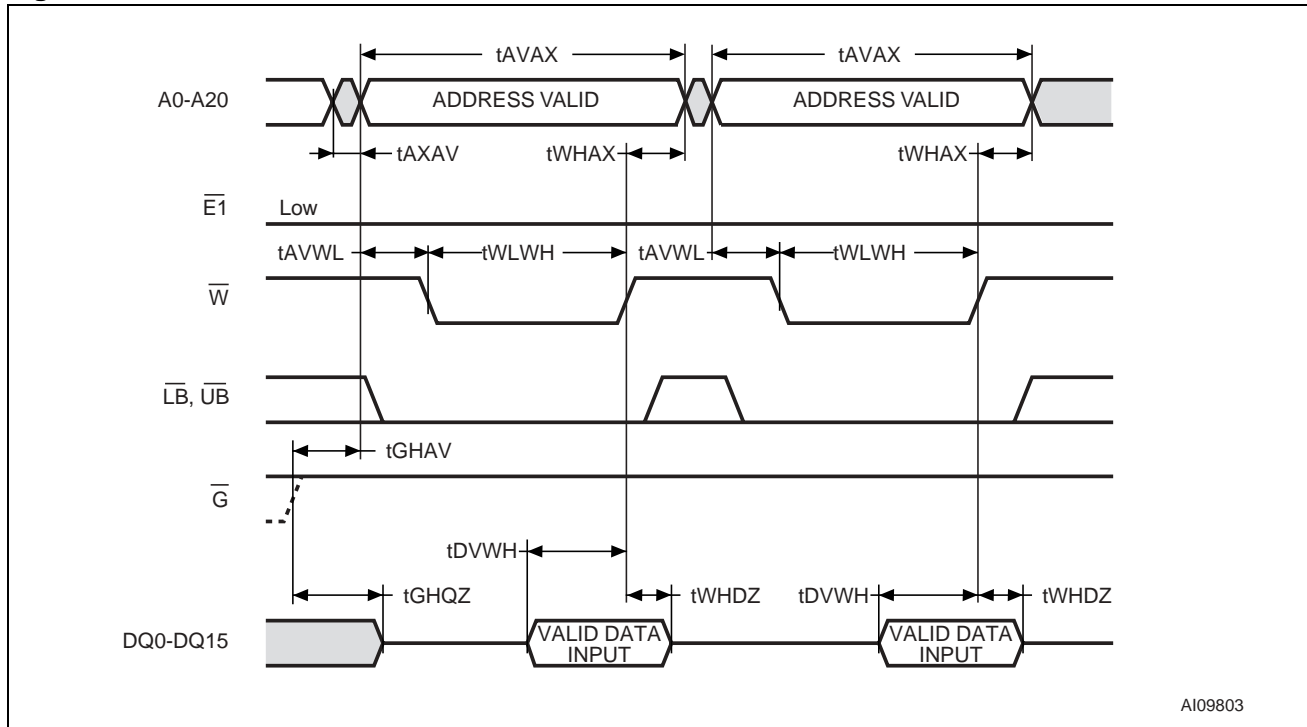

Note: E2 = High.

Figure 15. Write Enable and $\overline{UB}/\overline{LB}$ Controlled, Write AC Waveforms 1

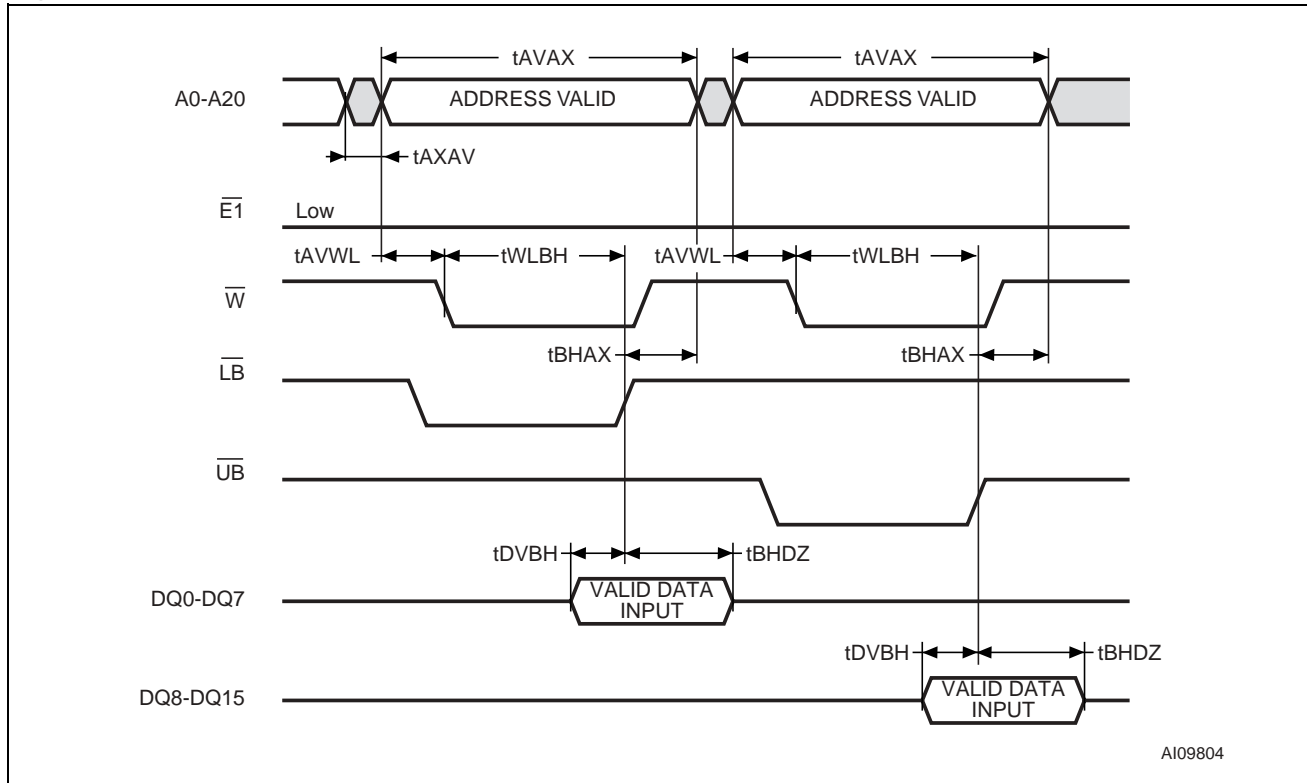

Note: E2 = High.

Figure 16. Write Enable and $\overline{UB}/\overline{LB}$ Controlled, Write AC Waveforms 2

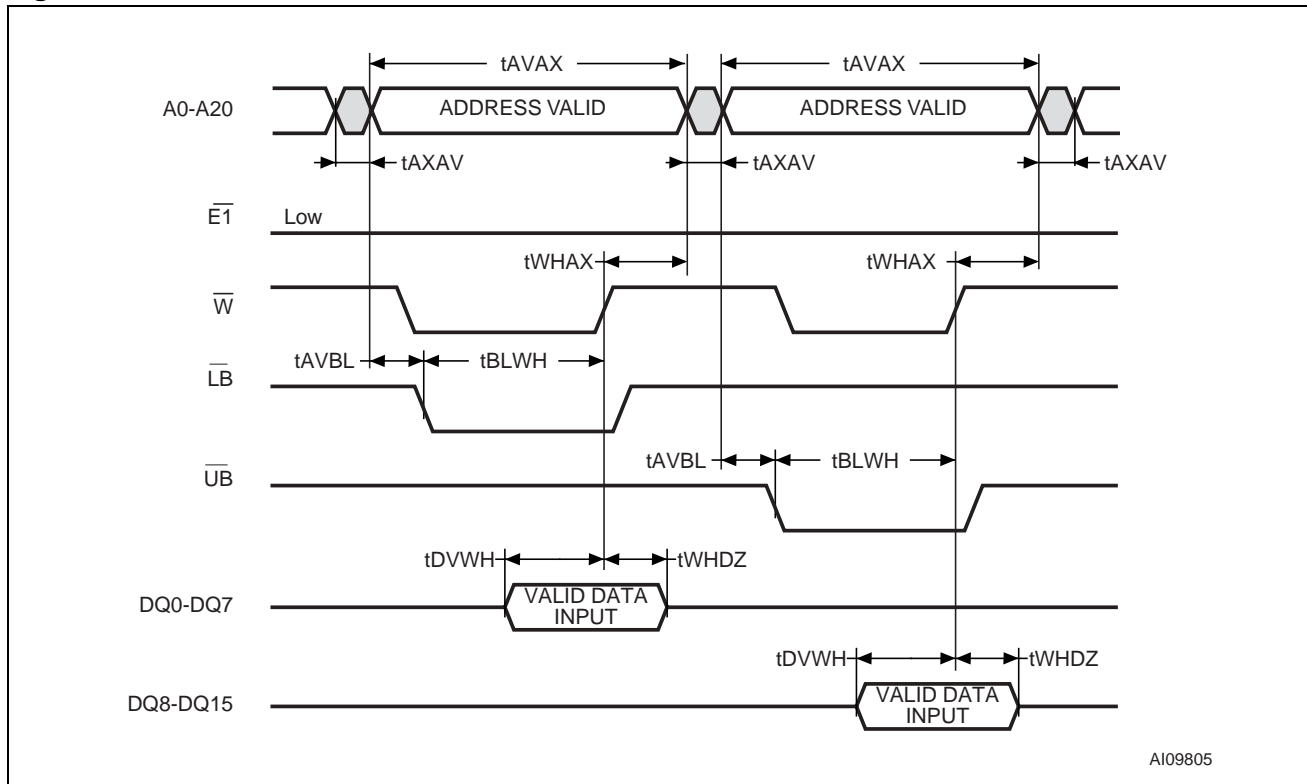

Note: E2 = High.

Figure 17. Write Enable and $\overline{UB}/\overline{LB}$ Controlled, Write AC Waveforms 3

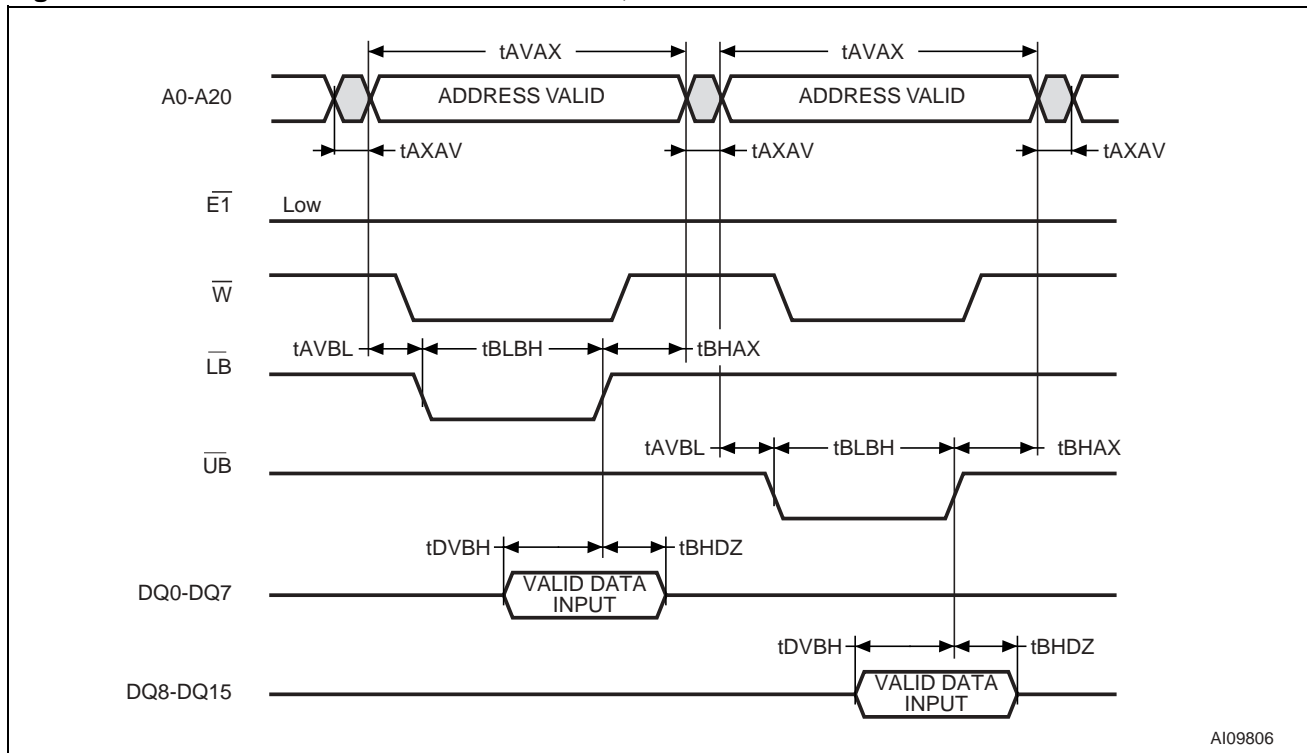

AI09806

Note: E2 = High.

Figure 18. Write Enable and $\overline{UB}/\overline{LB}$ Controlled, Write AC Waveforms 4

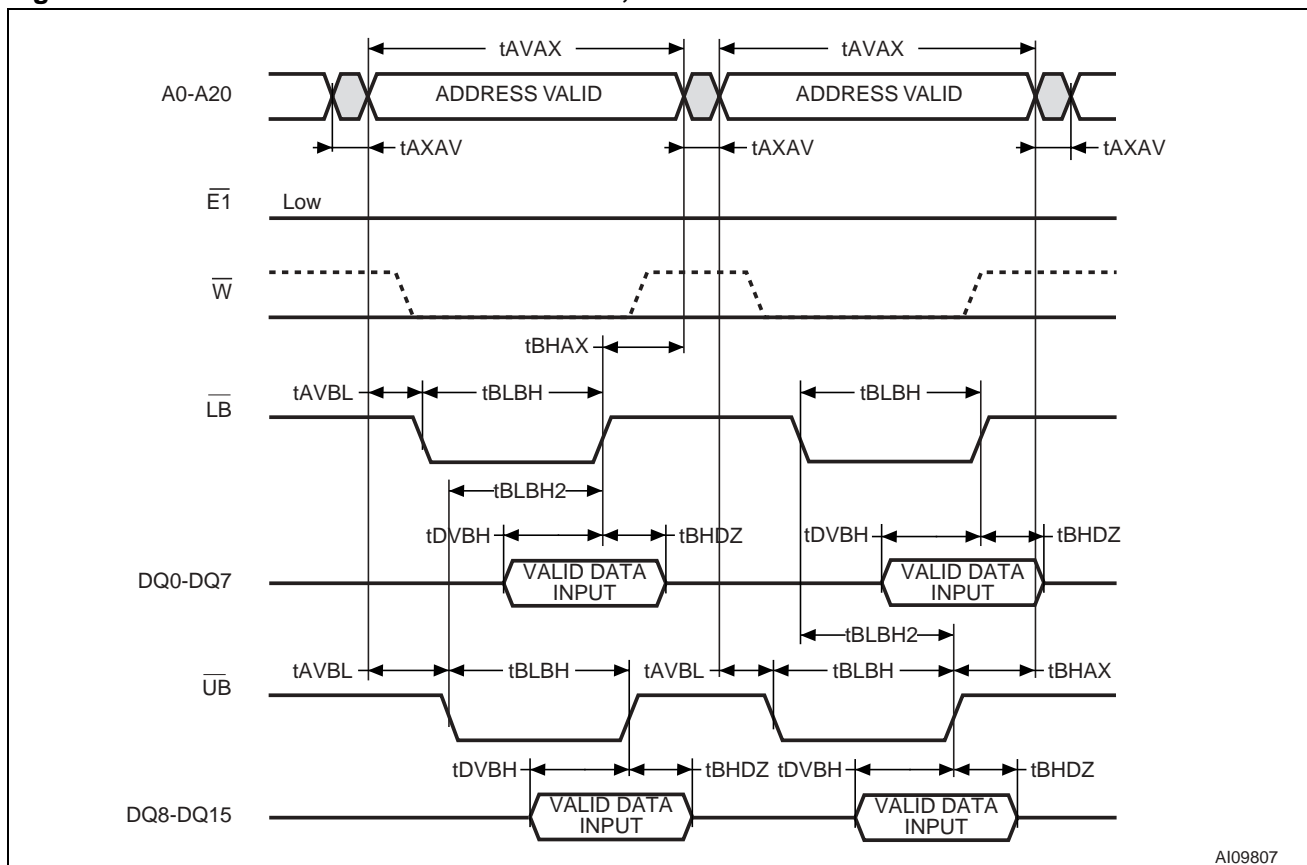

AI09807

Note: E2 = High.

Figure 19. Chip Enable Controlled, Read and Write Mode AC Waveforms

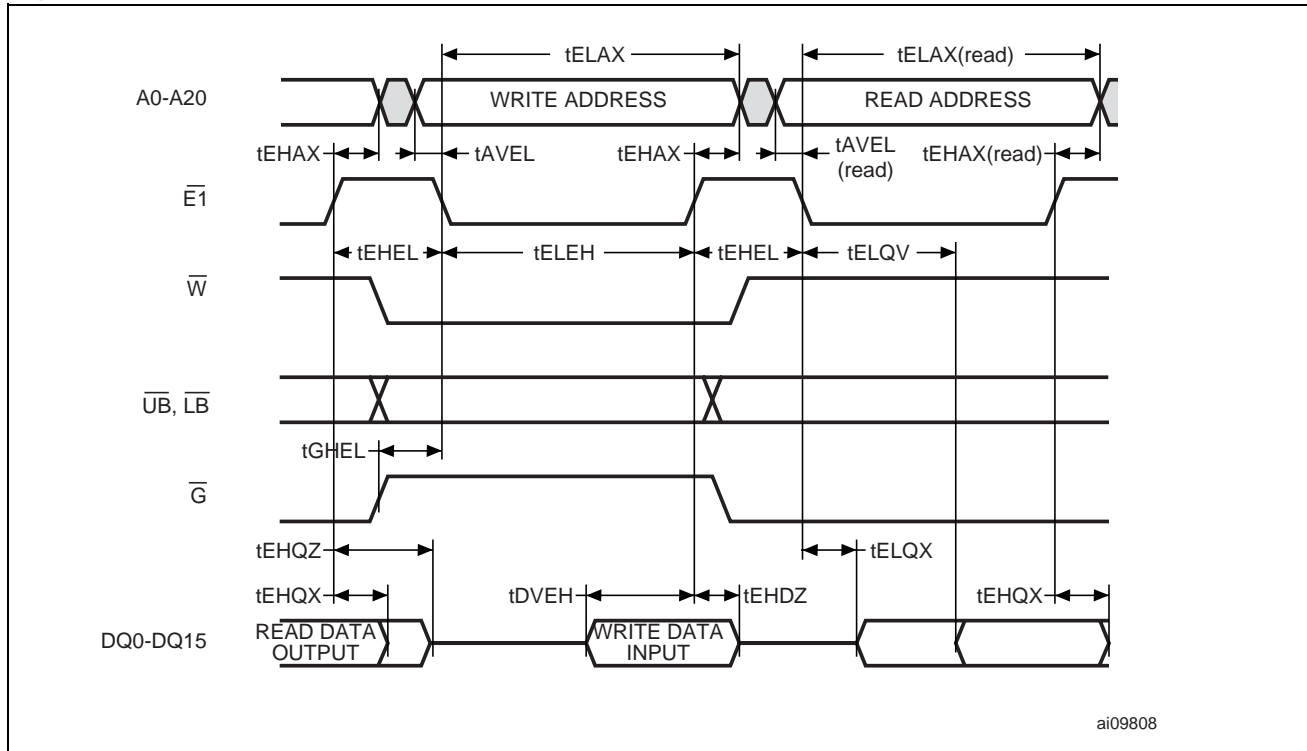

Note: Write address is valid from either $\overline{E1}$ or \overline{W} of last falling edge.

Figure 20. Chip Enable, Write Enable, Output Enable Controlled, Read/Write AC Waveforms

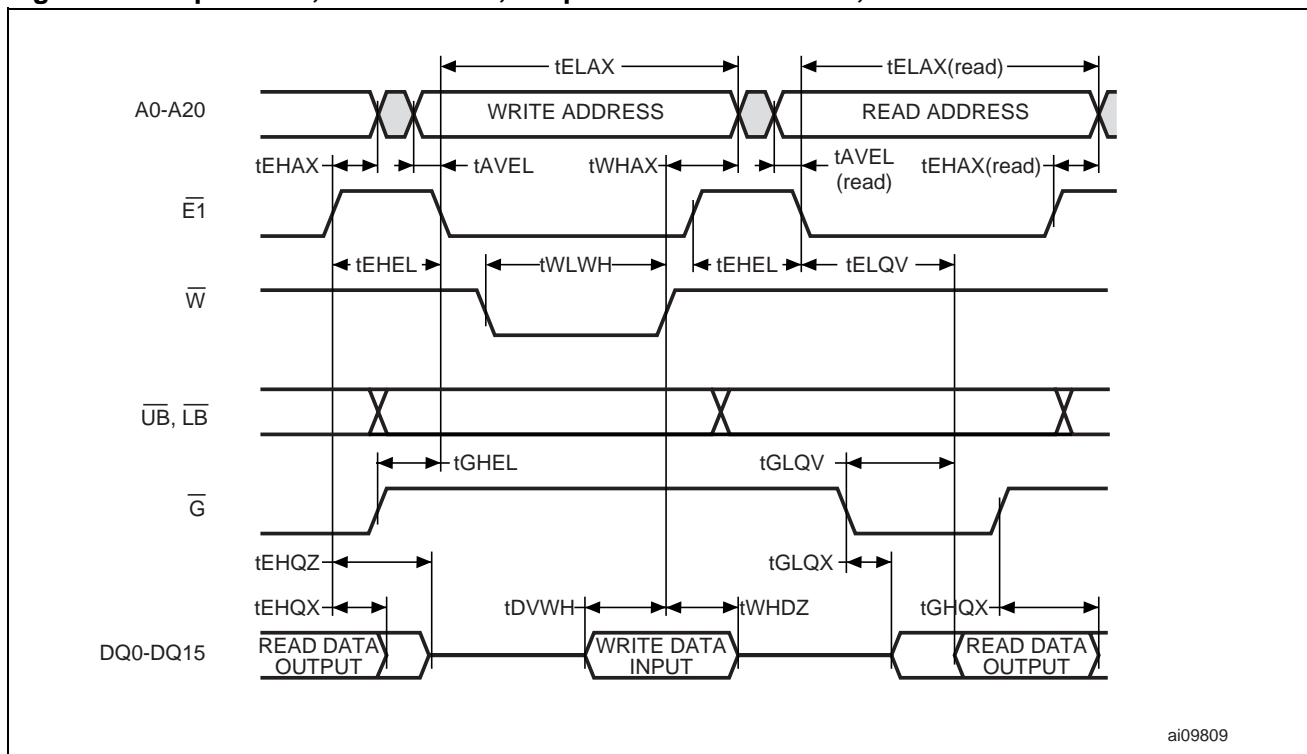

Note: \overline{G} can be Low fixed in write operation under $\overline{E1}$ control read-write-read operation.

Figure 21. Output Enable and Write Enable Controlled, Read and Write Mode AC Waveforms

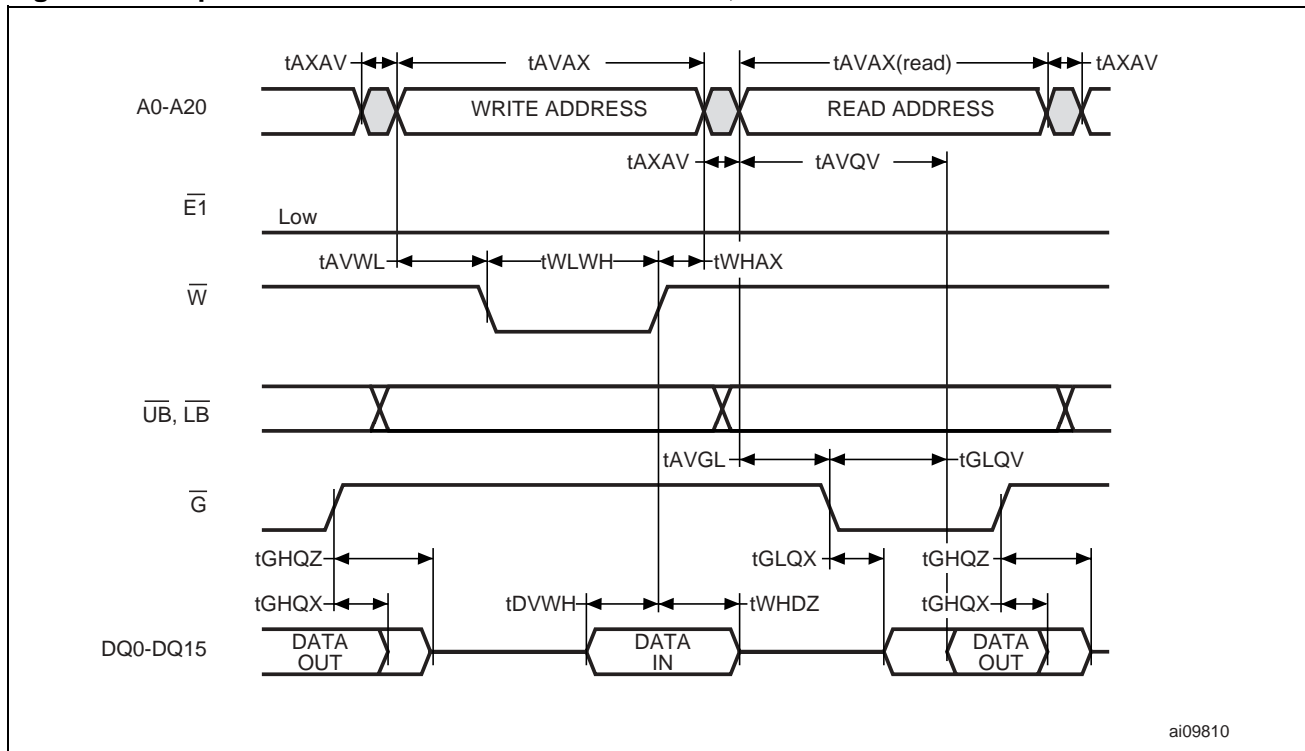

Note: $\bar{E}1$ can be tied to Low for \bar{W} and \bar{G} controlled operation.
When $\bar{E}1$ is tied to Low, output is exclusively controlled by \bar{G} .

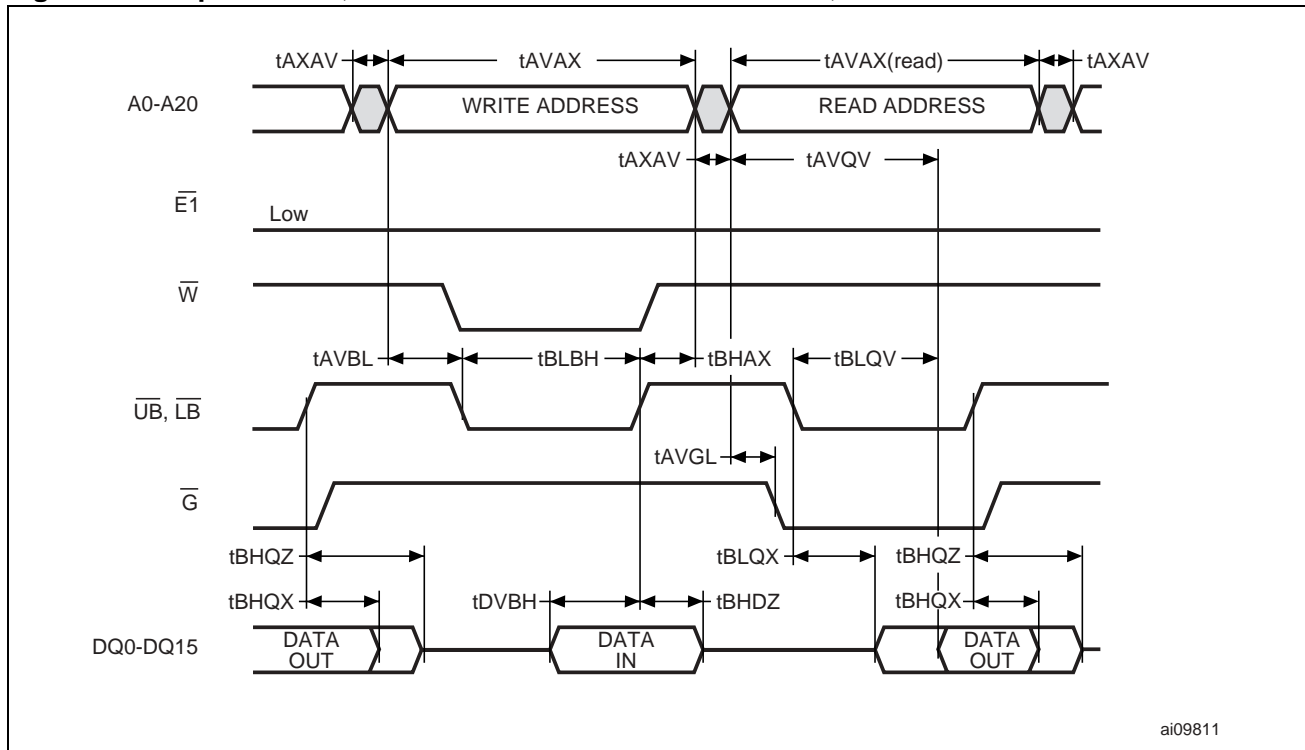
Figure 22. Output Enable, Write Enable and $\bar{U}B/\bar{L}B$ Controlled, Read/Write AC Waveforms

Note: $\bar{E}1$ can be tied to Low for \bar{W} and \bar{G} controlled operation.
When $\bar{E}1$ is tied to Low, output is exclusively controlled by \bar{G} .

Table 13. Standby Mode AC Characteristics

| Symbol | Alt. | Parameter | M69AR048B | | Unit |
|------------------|------------|--|-----------|-----|---------|
| | | | 80, 85 | | |
| | | | Min | Max | |
| t_{CLEX} | t_{CSP} | E2 Low Setup Time for Power-Down Entry | 10 | | ns |
| t_{EXCH} | t_{C2LP} | E2 Low Hold Time after Power-Down Entry | 85 | | ns |
| $t_{EHEV}^{(1)}$ | t_{CHH} | $\overline{E1}$ High Hold Time following E2 High after Power-Down Exit (Deep Power-Down Mode only) | 300 | | μs |
| $t_{CHEL}^{(2)}$ | t_{CHHP} | $\overline{E1}$ High Hold Time following E2 High after Power-Down Exit (not in Deep Power-Down Mode) | 1 | | μs |
| t_{EHCH} | t_{CHS} | $\overline{E1}$ High Setup Time following E2 High after Power-Down Exit | 0 | | μs |
| t_{EHGL} | t_{CHOX} | $\overline{E1}$ High to \overline{G} Invalid Time for Standby Entry | 10 | | ns |
| $t_{EHWL}^{(3)}$ | t_{CHWX} | $\overline{E1}$ High to \overline{W} Invalid Time for Standby Entry | 10 | | ns |
| $t_{\tau}^{(4)}$ | t_{τ} | Input Transition Time | 1 | 25 | ns |

- Note: 1. Applicable also to Power-up.
 2. Applicable when 4M, 8M or 16M Partial Power-Down mode is programmed
 3. Some data might be written into any address location if t_{EHWL} (min) is not satisfied.
 4. The Input Transition Time (t_{τ}) at AC testing is 5ns as shown below. If actual t_{τ} is longer than 5ns, it may violate AC specification of some timing parameters.

Figure 23. Power-Down Programming AC Waveforms

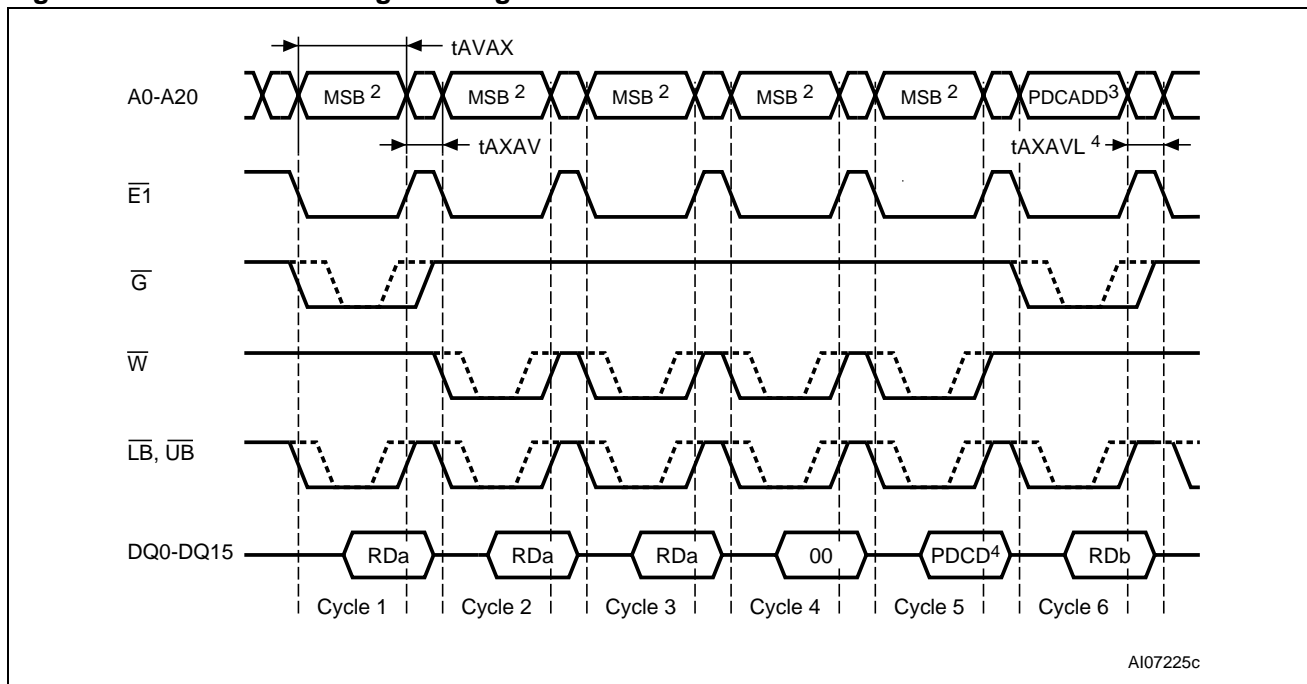

- Note: E2 = High.
 1. All address inputs must be High from Cycle 1 to Cycle 5.
 2. PDCADD stands for Power-Down Configuration Address. It must be compliant with the format specified in Table 6 otherwise the data programmed during the Power-Down Program sequence may be incorrect.
 3. PDCDAT stands for Power-Down Configuration Data. It must be compliant with the format specified in Table 5 otherwise the data programmed during the Power-Down Program sequence may be incorrect.
 4. t_{EHEL} after the end of Cycle 6, the Power-Down Program is completed and the device returns to normal operation.

Figure 24. Power-Down Mode AC Waveforms

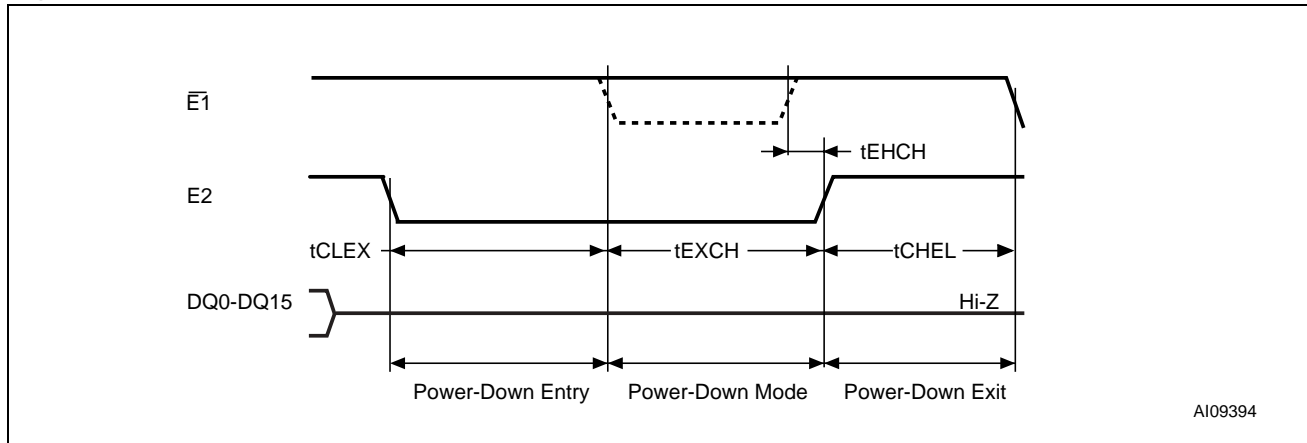

Figure 25. Power-Up Mode AC Waveforms

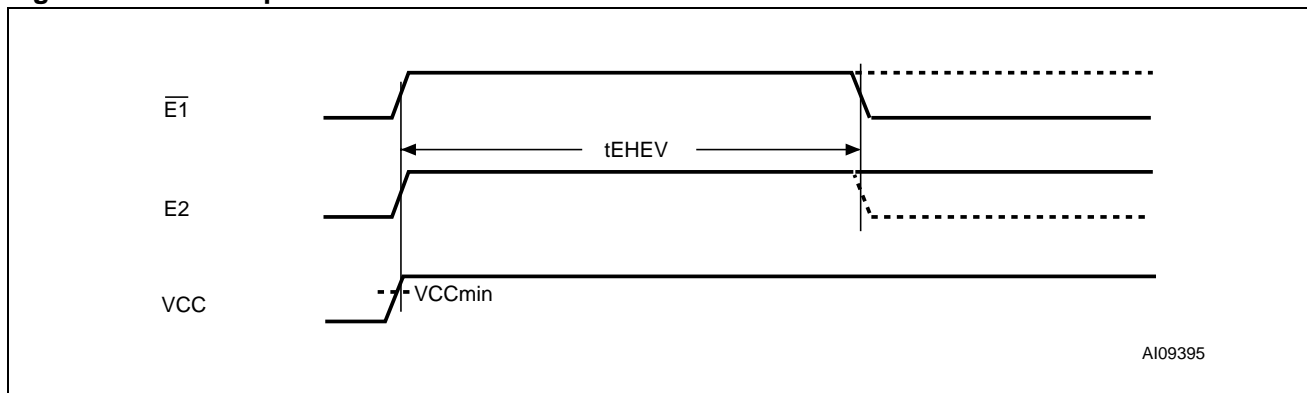
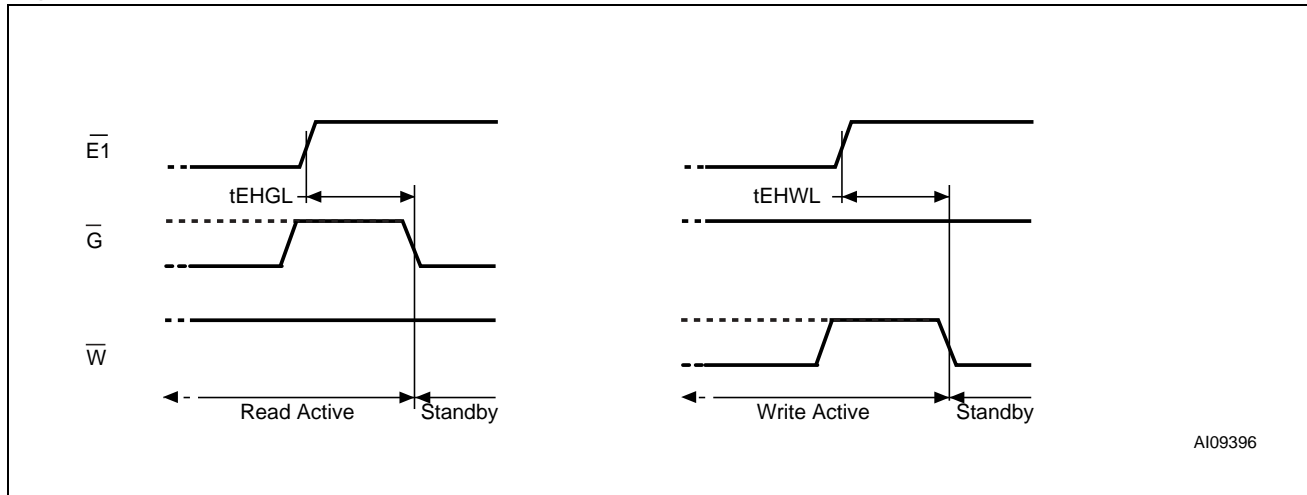

Figure 26. Standby Mode Entry AC Waveforms, After Read



Note: $E2 = \text{High}$.

PACKAGE MECHANICAL

Figure 27. TFBGA48 6x8mm - 6x8 ball array, 0.75 mm pitch, Package Outline, Bottom View

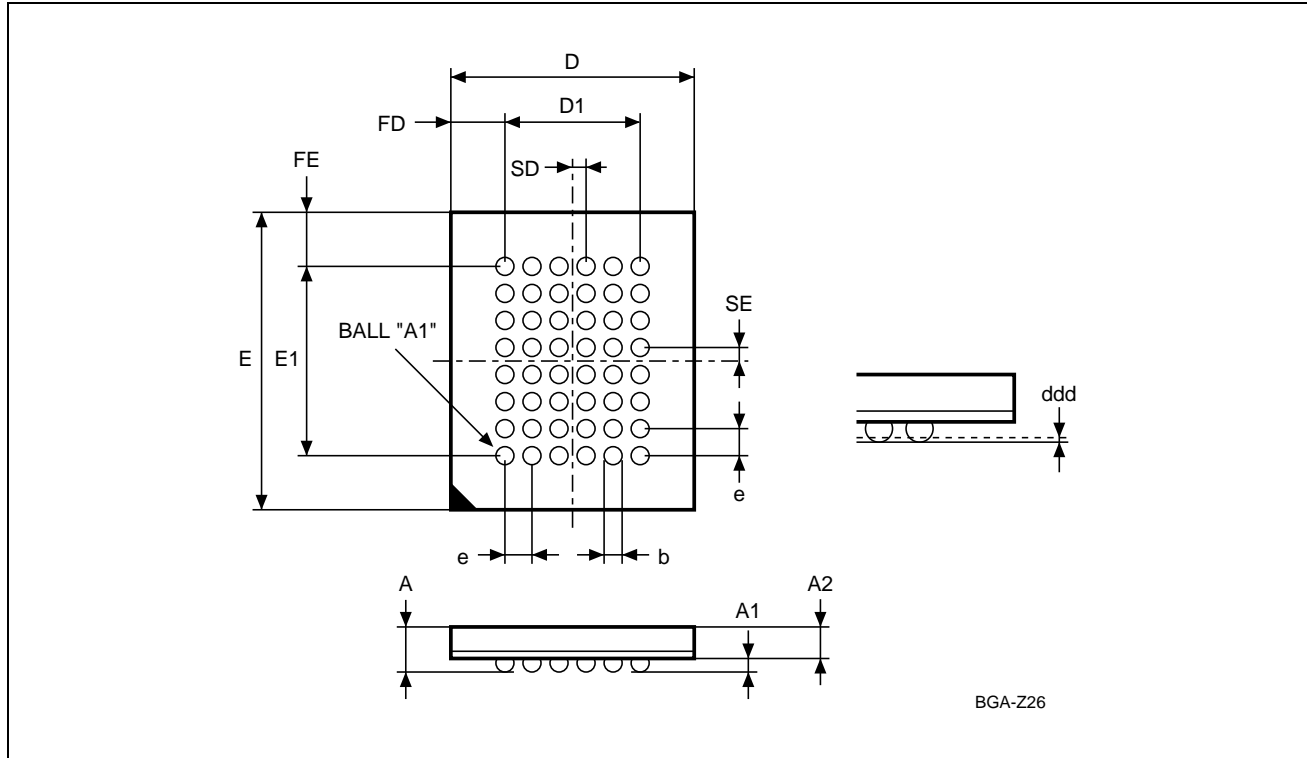

Note: Drawing is not to scale.

Table 14. TFBGA48 6x8mm - 6x8 ball array, 0.75 mm pitch, Package Mechanical Data

| Symbol | millimeters | | | inches | | |
|--------|-------------|-------|-------|--------|--------|--------|
| | Typ | Min | Max | Typ | Min | Max |
| A | | | 1.200 | | | 0.0472 |
| A1 | | 0.260 | | | 0.0102 | |
| A2 | | | 0.900 | | | 0.0354 |
| b | | 0.350 | 0.450 | | 0.0138 | 0.0177 |
| D | 6.000 | 5.900 | 6.100 | 0.2362 | 0.2323 | 0.2402 |
| D1 | 3.750 | – | – | 0.1476 | – | – |
| ddd | | | 0.100 | | | 0.0039 |
| E | 8.000 | 7.900 | 8.100 | 0.3150 | 0.3110 | 0.3189 |
| E1 | 5.250 | – | – | 0.2067 | – | – |
| e | 0.750 | – | – | 0.0295 | – | – |
| FD | 1.125 | – | – | 0.0443 | – | – |
| FE | 1.375 | – | – | 0.0541 | – | – |
| SD | 0.375 | – | – | 0.0148 | – | – |
| SE | 0.375 | – | – | 0.0148 | – | – |

PART NUMBERING

Table 15. Ordering Information Scheme

| Example: | M69AR048 | B | L | 80 | ZB | 8 |
|--|----------|---|---|----|----|---|
| Device Type M69 = 1T/1C Memory Cell Architecture | | | | | | |
| Mode A = Asynchronous | | | | | | |
| Operating Voltage R = 1.65V to 1.95V | | | | | | |
| Array Organization 048 = 32 Mbit (2Mb x16) | | | | | | |
| Option 1 B = 2 Chip Enable | | | | | | |
| Option 2 L = Low Leakage | | | | | | |
| Speed Class 80= 80ns (Access time = 70ns for $V_{CC} = 1.75V$ to 1.95V) 85= 85ns (Access time = 70ns for $V_{CC} = 1.75V$ to 1.95V) | | | | | | |
| Package ZB = TFBGA48, 0.75mm pitch | | | | | | |
| Operative Temperature 8 = -30 to 85 °C | | | | | | |

The notation used for the device number is as shown in Table 15. For a list of available options (speed, package, etc.) or for further information on any aspect of this device, please contact your nearest STMicroelectronics Sales Office.

REVISION HISTORY

Table 16. Document Revision History

| Date | Rev. | Revision Details |
|-------------|------|---|
| July 2002 | 1.0 | First Issue |
| 27-Sep-2002 | 2.0 | Document completely revised. Part Numbering clarified |
| 09-Oct-2002 | 2.1 | Part Numbering changed |
| 12-Mar-2003 | 3.0 | Document completely revised. Speed class changed to 80ns. Timing diagrams changed. Voltage levels for operating modes changed. |
| 22-Apr-2003 | 3.1 | 85ns speed class added. Correction to signal description in Write Mode section; tBLQZ,ELQZ,GLQZ renamed as tBLQX,ELQX,GLQX in Read Mode AC Characteristics; a minor label correction in a timing diagram; and value of tEXCH(min) changed |
| 24-Apr-2003 | 3.2 | Values for tPRC, tRC and tWC corrected in Read Mode and Write Mode AC Characteristics tables |
| 16-Jun-2003 | 3.3 | Binary address column in Address Key table corrected |
| 04-Jul-2003 | 3.4 | 70ns speed class added. tEXCH timing modified in Table 13, Standby Mode AC Characteristics. |
| 07-Jul-2003 | 3.5 | Entries for tAVEL and tEHAX corrected to -5ns. Document status set to Preliminary Data. |
| 17-Jul-2003 | 3.6 | Chip enable signals $\overline{E1}$ and E2 must change together during Power-on sequence |
| 07-Apr-2004 | 4.0 | Input capacitance added to Figure 5. , and title changed to AC Measurement Load Circuit 1. Figure 6. , AC Measurement Load Circuit 2. Table 11. , Read Mode AC Characteristics , and associated notes modified. tEHQV parameter changed to tEHQX in Figure 9. , Address and Output Enable Controlled, Read Mode AC Waveforms . Note 2 to Figure 10. , UB/LB Controlled, Read Mode AC Waveforms , modified. "Data key" and "Address key" replaced by "Power-Down Configuration Data" and "Power-Down Configuration Address". "Sleep" replaced by "Deep Power-down". Write Mode section corrected. All drawings converted to STMicroelectronics standard. For conformity with Figure 13. , Chip Enable Controlled, Write AC Waveforms , tEHDX, tBHDX and tWHDX changed to tEHDZ, tBHDZ and tWHDZ, respectively in Table 12. , Write Mode AC Characteristics . |
| 5-Oct-2005 | 5.0 | Datasheet status updated to Full Datasheet. Note 3 removed from in tBHQZ, tEHQZ and tGHQZ Table 11. , Read Mode AC Characteristics . |

Information furnished is believed to be accurate and reliable. However, STMicroelectronics assumes no responsibility for the consequences of use of such information nor for any infringement of patents or other rights of third parties which may result from its use. No license is granted by implication or otherwise under any patent or patent rights of STMicroelectronics. Specifications mentioned in this publication are subject to change without notice. This publication supersedes and replaces all information previously supplied. STMicroelectronics products are not authorized for use as critical components in life support devices or systems without express written approval of STMicroelectronics.

The ST logo is a registered trademark of STMicroelectronics.

All other names are the property of their respective owners.

© 2005 STMicroelectronics - All rights reserved

STMicroelectronics GROUP OF COMPANIES

Australia - Belgium - Brazil - Canada - China - Czech Republic - Finland - France - Germany -
Hong Kong - India - Israel - Italy - Japan - Malaysia - Malta - Morocco - Singapore -
Spain - Sweden - Switzerland - United Kingdom - United States

www.st.com

