

## OVERVIEW

The SM8140A is designed for using as EL (Electronic Luminescence) sheet driver require very low external parts counts, this result that very compact and thin EL driver units can be made.

Also this device has the features to use in wider range of applications demanding low quiescent current, low supply voltages, low operating supply currents, simple brightness control and low EMI (Electro-Magnetic Interference) emission due to the inherent smooth driver wave forms.

## FEATURES

- Specially providing EL driver functions
- Non-transformer for compact outline
- Bipolar driving for high power efficiency
- Very low noise smooth driver wave forms
- Brightness control with driving frequency change (An external resistance determines the driving frequency)
- Low power consumption by quiescent current control
- ON-chip high voltage output MOS transistor
- Large EL sheet (Exceeding 100 cm<sup>2</sup>) drivable
- supply voltage  
V<sub>DD</sub> = 2.4V to 3.6V or 5.0V
- 1.5V and 3V power applicable (Refer to APPLICATION HINTS)
- Maximum output driver voltage:200V<sub>P-P</sub>
- Typical driver frequency:250Hz
- 14 pin SSOP
- chip form

## ORDERING INFORMATION

Device	Package
SM8140AM	14pin SSOP
CF8140A	Chip in tray

## PIN OUT

( Top View )

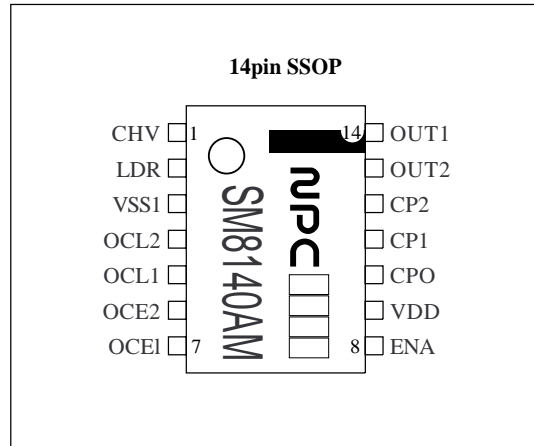

## PIN OUT

( Unit : mm )

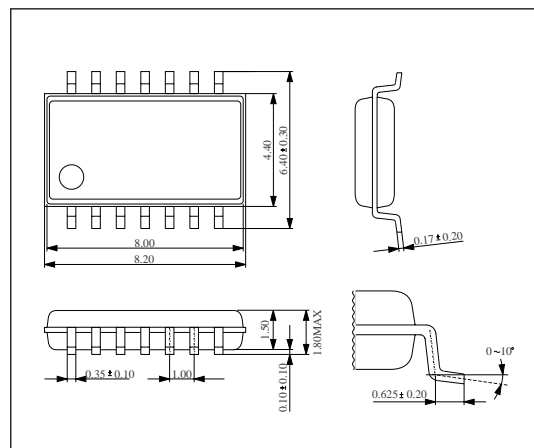

**PAD DIMENSIONS**

( UNIT:μm )

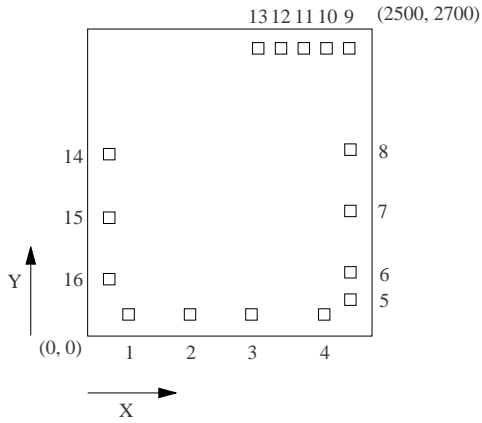

Chip size : 2.50 × 2.70mm  
 Chip thickness : 4000 ± 30μm  
 Pad size : 100 × 100μm  
 Chip reverse side : V<sub>SS</sub>

**PAD COORDINATES**

No.	NAME	X	Y
1	OCE2	360	190
2	OCE1	900	190
3	ENA	1440	190
4	VSS2	2080	190
5	VDD	2310	320
6	CPO	2310	560
7	CP1	2310	1100
8	CP2	2310	1640
9	OUT2	2300	2530
10	OUT1	2100	2530
11	CHV	1900	2530
12	MONG	1700	2530
13	LDR	1500	2530
14	VSS1	190	1600
15	OCL2	190	1040
16	OCL1	190	500

Note : MONG is test pin.  
 MONG and VSS2 are not bonding.

**BLOCK DIAGRAM**

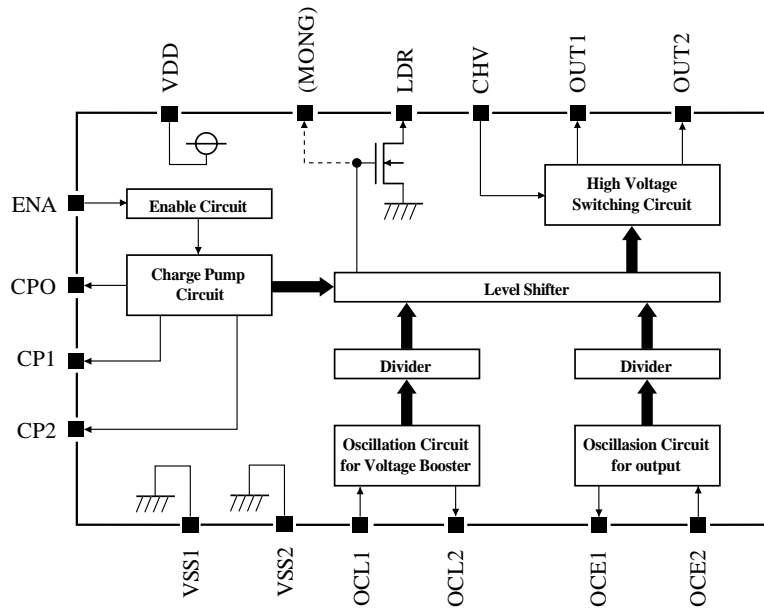

**PIN DESCRIPTION**

SSOP	chip	Pin Name	i / o	Function
1	11	CHV	i	DC high voltage pin
-	12	MONG	o	Monitor gate
2	13	LDR	o	Step – up inductor driver output
3	14	VSS1	-	GND
-	4	VSS2	-	GND
4	15	OCL2	o	CR oscillator pin for step – up inductor and charge pump. External resistor at this pin determines oscillator frequency.
5	16	OCL1	i	
6	1	OCE2	i	CR oscillator pin for output
7	2	OCE1	o	External resistor at this pin determines oscillator frequency
8	3	ENA	ip <sup>1</sup>	Output control pin. Output from OUT1 and OUT2 pins are stopped When "L".
9	5	VDD	-	Power supply pin
10	6	CPO	o	Charge pump output (Voltage output for driving high voltage MOS)
11	7	CP1	o	Charge pump external capacitor pin
12	8	CP2	o	Charge pump external capacitor pin
13	9	OUT2	o	Output for EL
14	10	OUT1	o	Output for EL

1. "ip" defines input pin with pull down internal resistor

## ABSOLUTE MAXIMUM RATINGS

$V_{SS} = 0V$ , Unless otherwise noted

Parameter	Symbol	Condition	Rating	unit
Supply voltage range	$V_{DD}$		- 0.3 to + 8.0	V
Input voltage range	$V_{IN}$	All input pins	$V_{SS} - 0.3$ to $V_{DD} + 0.3$	V
Output voltage	$V_{CHV}$	CHV pins	0.5 to 120	V
	$V_{LDR}$	LDR pins	0.5 to 120	
	$V_{OUT1}$	OUT1 pins	0.5 to 120	
	$V_{OUT2}$	OUT2 pins	0.5 to 120	
Power dissipation	$P_D$	$T_a \leq 70^\circ C$	200	mW
Storage temperature range	$T_{STG}$		- 55 to 125	$^\circ C$
Soldering temperature	$T_{SLD}$	Package only	255	$^\circ C$
Soldering time	$t_{SLD}$	Package only	10	sec

## RECOMMENDED OPERATING CONDITIONS

$V_{SS} = 0V$ , Unless otherwise noted

Parameter	Symbol	Condition	Rating			unit
			min	typ	max	
Supply voltage range	$V_{DD1}$		2.4	-	3.6	V
	$V_{DD2}$	$CPO = V_{DD}^1$	4.5	-	5.5	V
Operating temperature range	$T_{OPR}$		- 30	-	70	$^\circ C$
Operating current <sup>2</sup>	$I_{DD2}$	Including inductor current, $V_{DD} = 3.0V$	-	20	100	mA
	$I_{DD3}$	Including inductor current, $V_{DD} = 5.0V$	-	25	100	mA
Using inductor	$L_{LDR1}$	$f_{LDR} = 32kHz, V_{DD} = 3.0V$	-	1.0	-	mH
	$L_{LDR2}$	$f_{LDR} = 32kHz, V_{DD} = 5.0V$	-	1.5	-	mH

1. 5V Application hints is different from 3V ones (Refer to APPLICATION HINTS)
2. Max value is as same as Absolute Maximum Ratings

## ELECTRICAL CHARACTERISTICS

$T_a = 25^\circ C, V_{SS} = 0V, V_{DD} = 3.0V$ , unless otherwise noted

Parameter	Pin	Symbol	Condition	Rating			unit
				min	typ	max	
Supply voltage range	VDD	$V_{DD}$		2.4	-	3.6	V
Output voltage	CPO	$V_{CPO}$	$V_{CPO} \leq 2 \times V_{DD}$	4.5	5.5	-	V
	CHV	$V_{CHV}$		0.5	-	100	
	OUT1/2	$V_{OUTH}$		-	-	100	
	OUT1/2	$V_{OUTL}$		-	-	0.5	
Output resistance	LDR	$R_{LDR}$	$V_{CPO} = 6.0V$	-	5.0	10.0	$\Omega$
Oscillation frequency	OCE1/2	$f_{OCE}$	$R_{OCE} = 3.9M\Omega$	5.6	8.0	10.4	kHz
	OCL1/2	$f_{OCL}$	$R_{OCL} = 100k\Omega^1$	179	256	332	
Driving frequency	OUT1/2	$f_{OUT}$	$R_{OCE} = 3.9M\Omega^2$	175	250	325	Hz
Output frequency	LDR	$f_{LDR}$	$R_{OCL} = 100k\Omega$	22.4	32	41.6	kHz
Input voltage	ENA	$V_{ENAH}$	ENA = "H"	$V_{DD} + 1.0$	-	$V_{DD} + 0.3$	V
		$V_{ENAL}$	ENA = "L"	$V_{SS} - 0.3$	-	$V_{SS} + 1.0$	
Input current	ENA	$I_{ENAH}$	$V_{ENAH} = 3.0V$	0.45	0.75	1.05	$\mu A$
Operating current	VDD	$I_{DD1}$	Excluding inductor current	-	-	1	mA
Stand - by current	VDD	$I_{STB}$	ENA = "L"	-	-	1	$\mu A$

1.  $R_{OSC}$  determines EL driver frequency 20k to 100kHz
2.  $R_{OSC}$  determines EL driver frequency 200 to 500Hz

APPLICATION HINTS

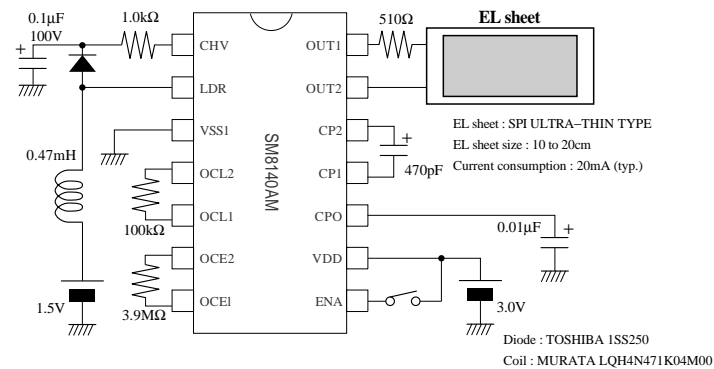
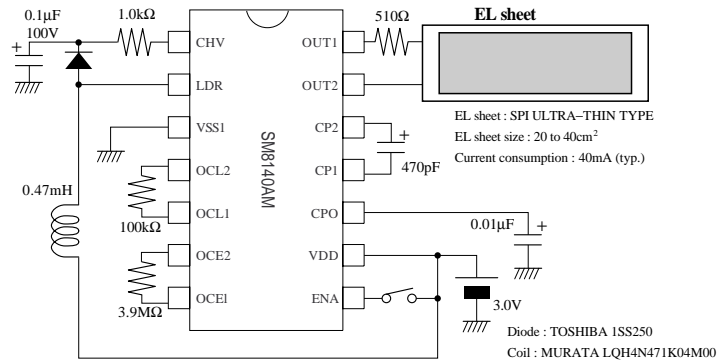
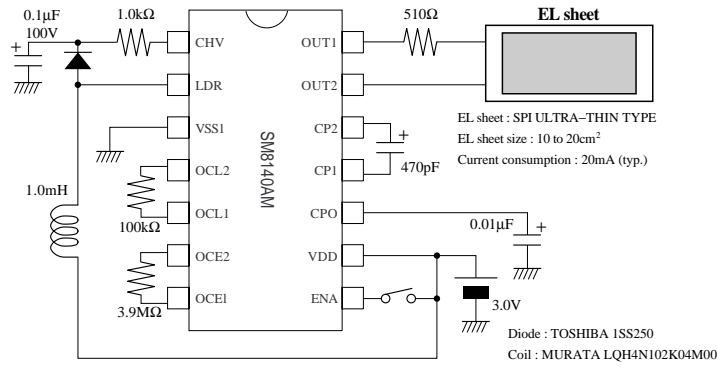

## SM8140A

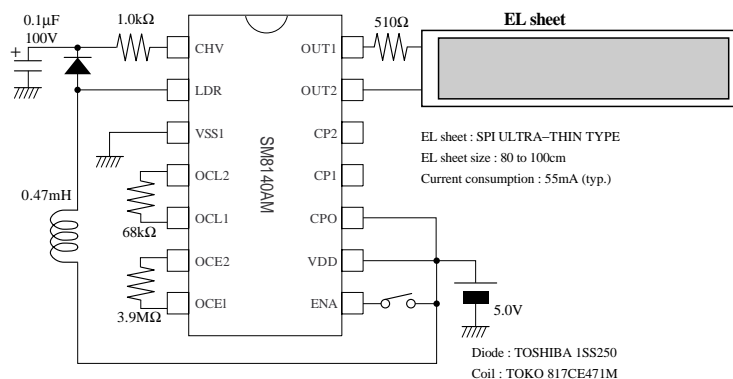
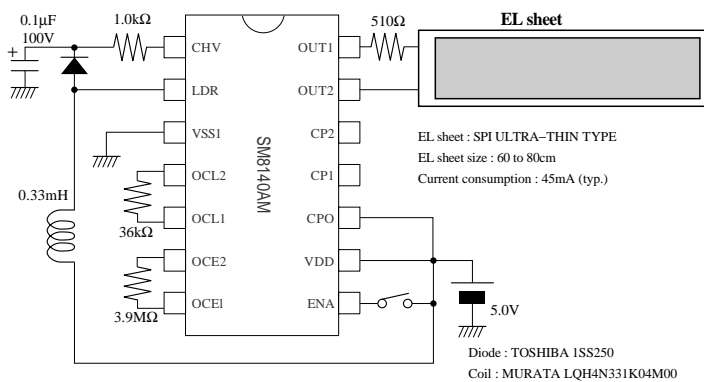
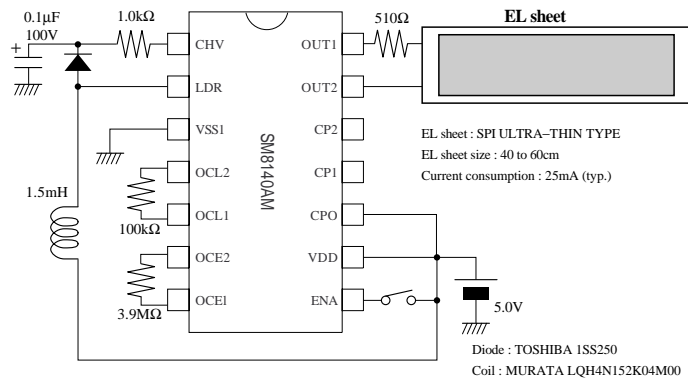

NIPPON PRECISION CIRCUITS INC. reserves the right to make changes to the products described in this data sheet in order to improve the design or performance and to supply the best possible products. Nippon Precision Circuits Inc. assumes no responsibility for the use of any circuits shown in this data sheet, conveys no license under any patent or other rights, and makes no claim that the circuits are free from patent infringement. Applications for any devices shown in this data sheet are for illustration only and Nippon Precision Circuits Inc. makes no claim or warranty that such applications will be suitable for the use specified without further testing or modification. The products described in this data sheet are not intended to use for the apparatus which influence human lives due to the failure or malfunction of the products. Customers are requested to comply with applicable laws and regulations in effect now and hereinafter, including compliance with export controls on the distribution or dissemination of the products. Customers shall not export, directly or indirectly, any products without first obtaining required licenses and approvals from appropriate government agencies..

**NPC**  
NIPPON PRECISION CIRCUITS INC.

NIPPON PRECISION CIRCUITS INC.

4-3, 2-chome Fukuzumi  
Koto-ku, Tokyo 135-8430, Japan  
Telephone: 03-3642-6661  
Facsimile: 03-3642-6698

NC9612CE 1998.03