

BTL Drive Single-phase Full-wave Fan Motor Driver
AM4951/R/2

General Description

The AM4951/R/2 series is a single-phase BTL output fan motor driver designed by bipolar process. This IC features high efficiency, silent operation and includes lock shutdown and automatic restart functions. When the motor is under lock condition, the lock shutdown function turns off the output current. When the lock condition is removed, the IC will restart automatically and allow DC fan to run. It is applied for high reliability and low noise application, such as personal computers, notebook, car audio, CPU cooling systems and power supplies in consumer electronics systems.

The AM4951/R series is available in MSOP-8 (12V application only) or PSOP-8 (24V application only) package. The AM4952 is available in MSOP-10 package.

Features

- BTL Output Single-phase Full-wave Linear Drive (Gain Resistor=1k to 360k Ω , Gain=51dB)
- Support Low-voltage Drive and Feature a Wide Usable Voltage Range (2.2V to 24V)
- Low Saturation Output (High Side and Low Side Saturation Voltage): $V_{SAT_TOTAL}=1.2V$ (typical, $I_{OUT}=250mA$)
- Built-in Lock Protection and Automatic Restart Circuits
- Built-in FG/RD Output
- Built-in Hall Sensor Bias (AM4952 Only, $V_{HB}=1.5V$)
- Thermal Protection Circuit
- Small-sized, High Thermal Capacity Package
- FG Output (AM4951), RD Output (AM4951R), FG and RD Output (AM4952)

Applications

- Notebook, Personal Computers
- Power Supplies in Consumer Electronics, Car Audio and Office Peripherals
- CPU Cooling Systems



Figure 1. Package Types of AM4951/R/2

Pin Configuration

MM Package
(MSOP-8)

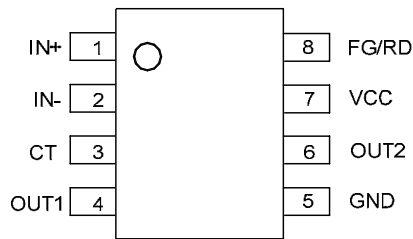

For AM4951/R 12V Application

MP Package
(PSOP-8)

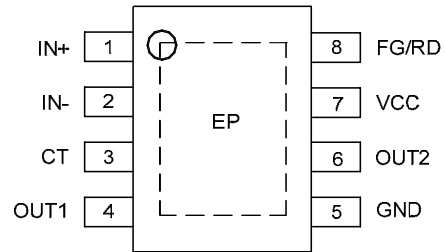

For AM4951/R 24V Application

MM Package
(MSOP-10)

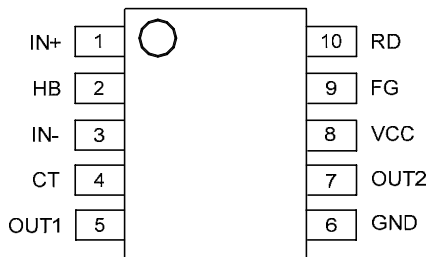

For AM4952

Figure 2. Pin Configuration of AM4951/R/2 (Top View)

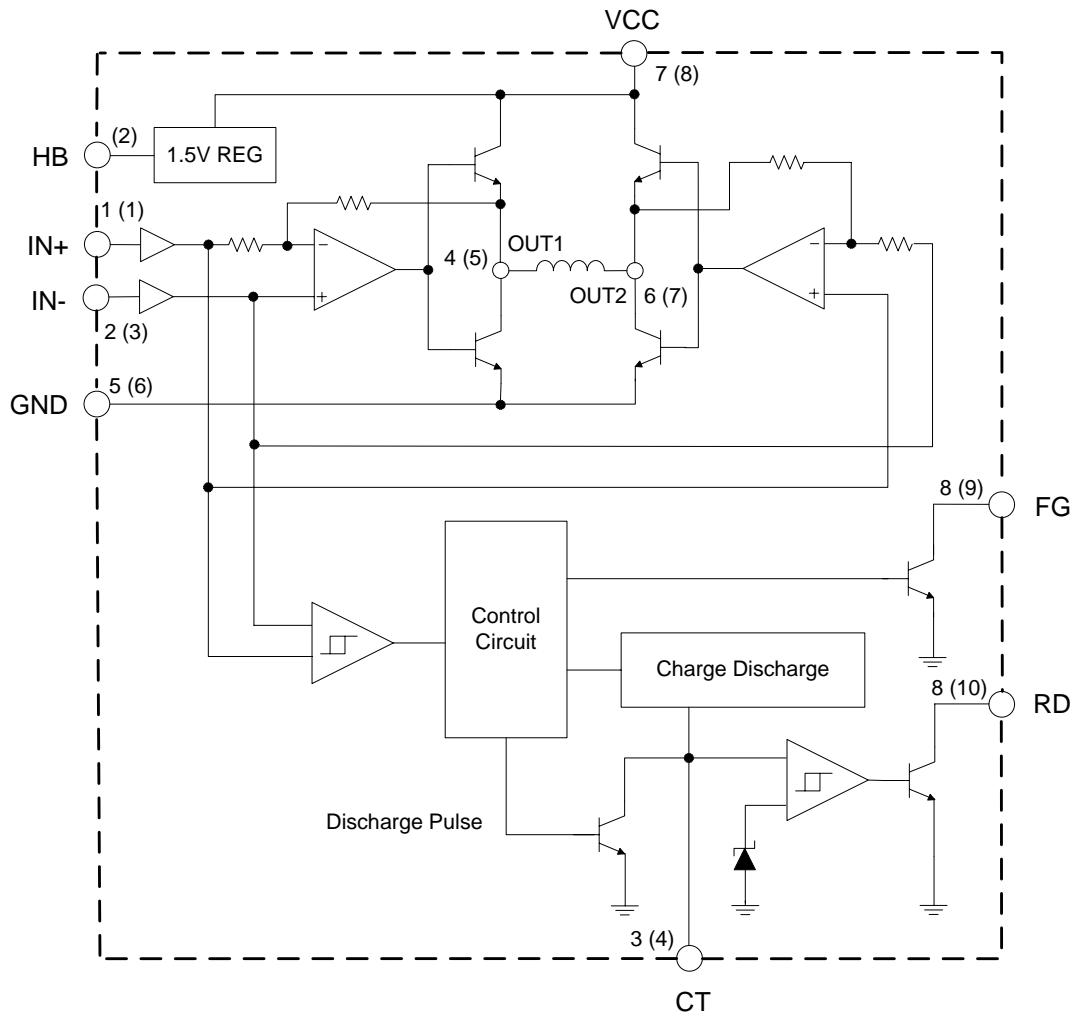
Functional Block Diagram

A (B)
 A for AM4951/R
 B for AM4952

Figure 3. Functional Block Diagram of AM4951/R/2



BTL Drive Single-phase Full-wave Fan Motor Driver

AM4951/R/2

Ordering Information

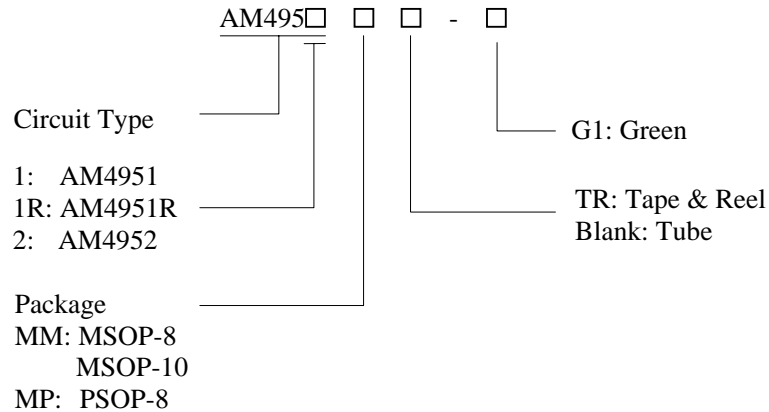

Package	Temperature Range	Output Signal	Part Number	Marking ID	Packing Type
MSOP-8	-40 to 105°C	FG	AM4951MM-G1	4951MM-G1	Tube
			AM4951MMTR-G1	4951MM-G1	Tape & Reel
		RD	AM4951RMM-G1	4951RMM-G1	Tube
			AM4951RMMTR-G1	4951RMM-G1	Tape & Reel
PSOP-8		FG	AM4951MP-G1	4951MP-G1	Tube
			AM4951MPTR-G1	4951MP-G1	Tape & Reel
		RD	AM4951RMP-G1	4951RMP-G1	Tube
			AM4951RMPTR-G1	4951RMP-G1	Tape & Reel
MSOP-10	FG & RD	AM4952MM-G1	4952MM-G1	Tube	
		AM4952MMTR-G1	4952MM-G1	Tape & Reel	

BCD Semiconductor's Pb-free products, as designated with "G1" suffix in the part number, are RoHS compliant and green.

**BTL Drive Single-phase Full-wave Fan Motor Driver****AM4951/R/2****Absolute Maximum Ratings (Note 1, $T_A=25^{\circ}\text{C}$)**

Parameter	Symbol	Value		Unit
Supply Voltage	V_{CC}	28		V
Peak Output Current	I_{OUT}	500		mA
FG/RD Pull-up Voltage	V_{FG}/V_{RD}	28		V
FG/RD Output Current	I_{FG}/I_{RD}	10		mA
Power Dissipation	P_D	MSOP-8	585	mW
		PSOP-8	960	mW
		MSOP-10	585	mW
Operating Temperature	T_{OP}	-40 to 125		$^{\circ}\text{C}$
Storage Temperature	T_{STG}	-55 to 150		$^{\circ}\text{C}$

Note 1: Stresses greater than those listed under “Absolute Maximum Ratings” may cause permanent damage to the device. These are stress ratings only, and functional operation of the device at these or any other conditions beyond those indicated under “Recommended Operating Conditions” is not implied. Exposure to “Absolute Maximum Ratings” for extended periods may affect device reliability.

Recommended Operating Conditions

Parameter	Symbol	Min	Max	Unit
Supply Voltage	V_{CC}	2.2	24	V
Hall Input Voltage	V_{ICM}	0	$V_{CC}-1.5$	V
Operating Ambient Temperature	T_A	-40	105	$^{\circ}\text{C}$

**BTL Drive Single-phase Full-wave Fan Motor Driver****AM4951/R/2****Electrical Characteristics** $V_{CC}=12V$, $T_A=25^{\circ}C$, unless otherwise specified.

Parameter	Symbol	Conditions	Min	Typ	Max	Unit
Supply Current	I_{CC1}	$V_{CT}=L$	3	6	9	mA
	I_{CC2}	$V_{CT}=H$	2.5	5	7.5	mA
CT Charge Current	I_{CHG}		0.9	1.3	1.5	μA
CT Discharge Current	I_{DHG}		0.1	0.15	0.25	μA
CT Charge/Discharge Current Ratio	R_{CT}	I_{CHG} / I_{DHG}	6	8	10	
CT Clamp Voltage	V_{CL}		1.3	1.5	1.7	V
CT Comparator Voltage	V_{CP}		0.3	0.5	0.7	V
OUT Low Saturation Voltage	V_{SAT_L}	$I_{OUT}=200mA$		0.25	0.45	V
OUT High Saturation Voltage	V_{SAT_H}	$I_{OUT}=200mA$		0.95	1.2	V
Hall Input Sensitivity	V_{HN}			7	15	mV
FG Low Level Voltage (For AM4951/2)	V_{FG}	$I_{FG}=5mA$		0.15	0.3	V
FG Leakage Current (For AM4951/2)	I_{FGL}	$V_{FG}=15V$		1	30	μA
RD Low Level Voltage (For AM4951R/2)	V_{RD}	$I_{RD}=5mA$		0.15	0.3	V
RD Leakage Current (For AM4951R/2)	I_{RDL}	$V_{RD}=15V$		1	30	μA
HB Voltage (For AM4952)	V_{HB}	$I_{HB}=1mA$	1.35	1.5	1.65	V



Typical Performance Characteristics

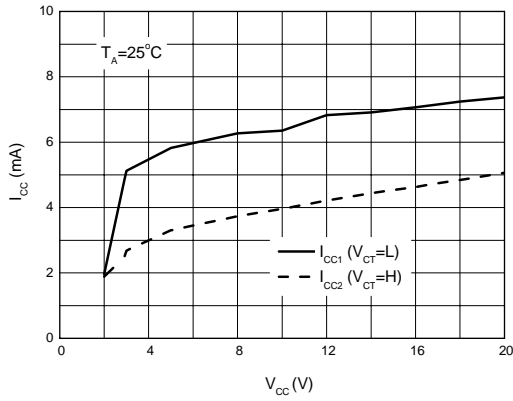

Figure 4. Supply Current vs. Supply Voltage

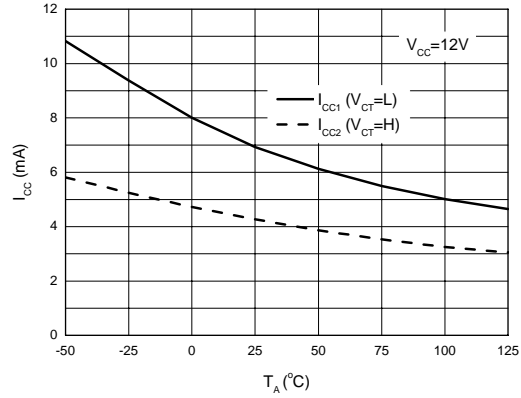

Figure 5. Supply Current vs. Ambient Temperature

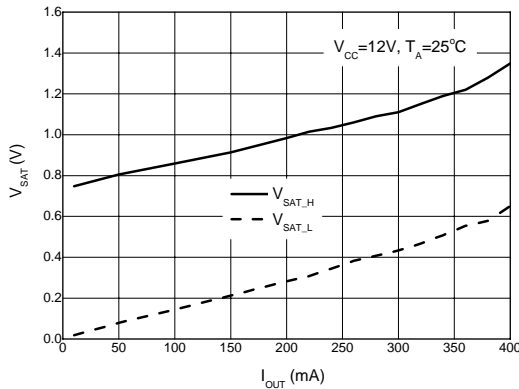

Figure 6. Saturation Voltage vs. Output Current

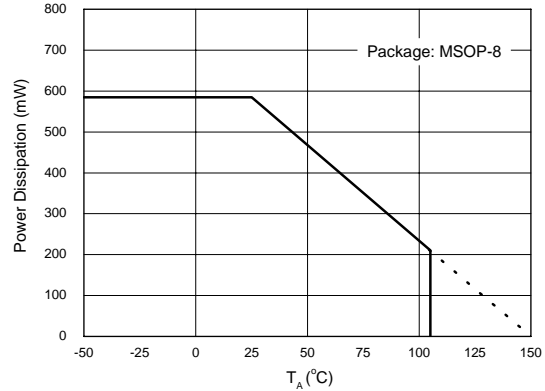

Figure 7. Power Dissipation vs. Ambient Temperature



Typical Performance Characteristics (Continued)

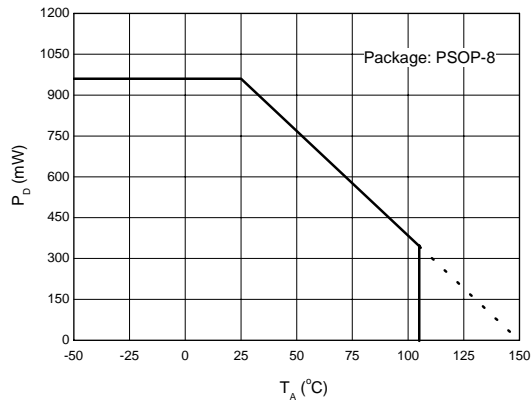
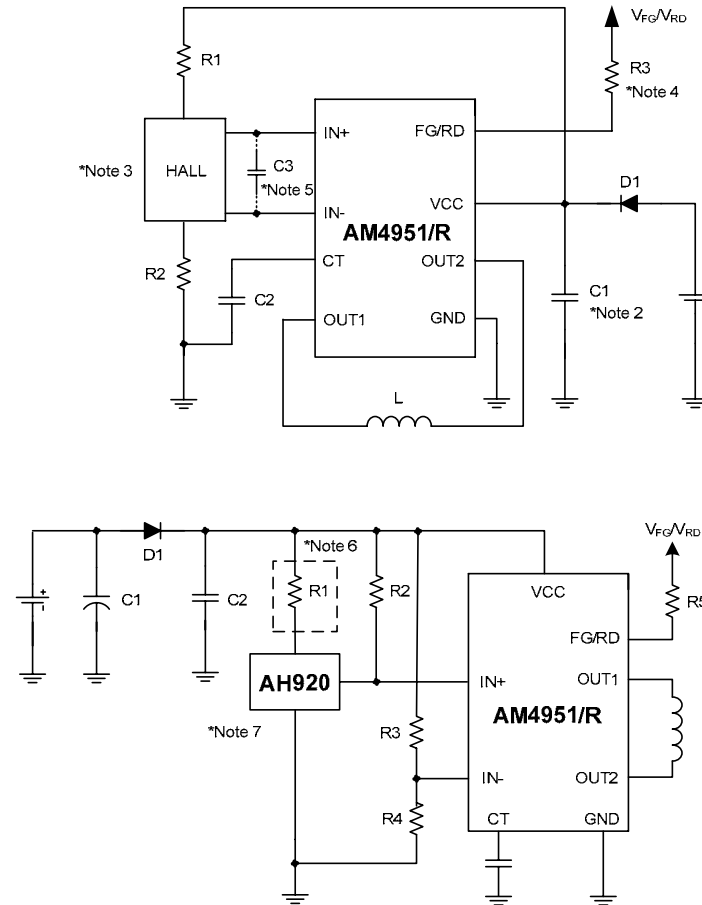

Figure 8. Power Dissipation vs. Ambient Temperature

Typical Application

Note 2: Adding D1 can protect the IC from destruction by reverse connection. If D1 is used, it is necessary to insert a capacitor C1 to provide a regenerative current route. Similarly, if there is no nearby capacitor on the fan power supply line, C1 will also be necessary to improve reliability. Its capacity should be larger than 2.2 μ F.

Note 3: If the Hall sensor bias is taken from V_{CC}, A 1/2 V_{CC} bias, as shown in the figure must be used. Adjusting the value of R1 and R2 may achieve better startup characteristics and efficiency, even quiet operation.

Note 4: This pin must be left open if unused.

Note 5: If the line between Hall sensor output and Hall sensor input of IC is long, the noise may occur in this line. But it can be eliminated by adding a capacitor C3.

Note 6: Each of R2, R3, R4 and R5 (AM4951/R only) is recommended to be 51k Ω typical. R1 is recommended to be 2k and must be added when V_{CC} is larger than 20V.

Note 7: The package of AH920 is SOT-23-3. If it is packaged in TO-92S-3, please exchange IN- with IN+.

Figure 9. Typical Application of AM4951/R

Typical Application (Continued)

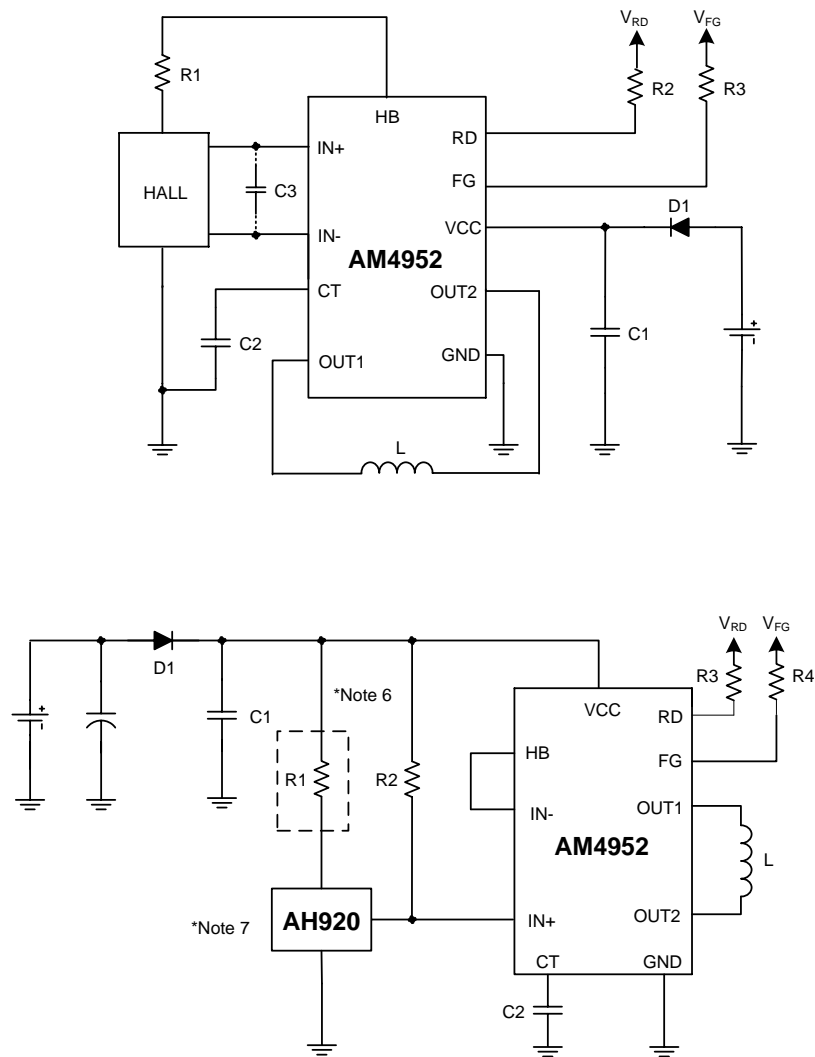
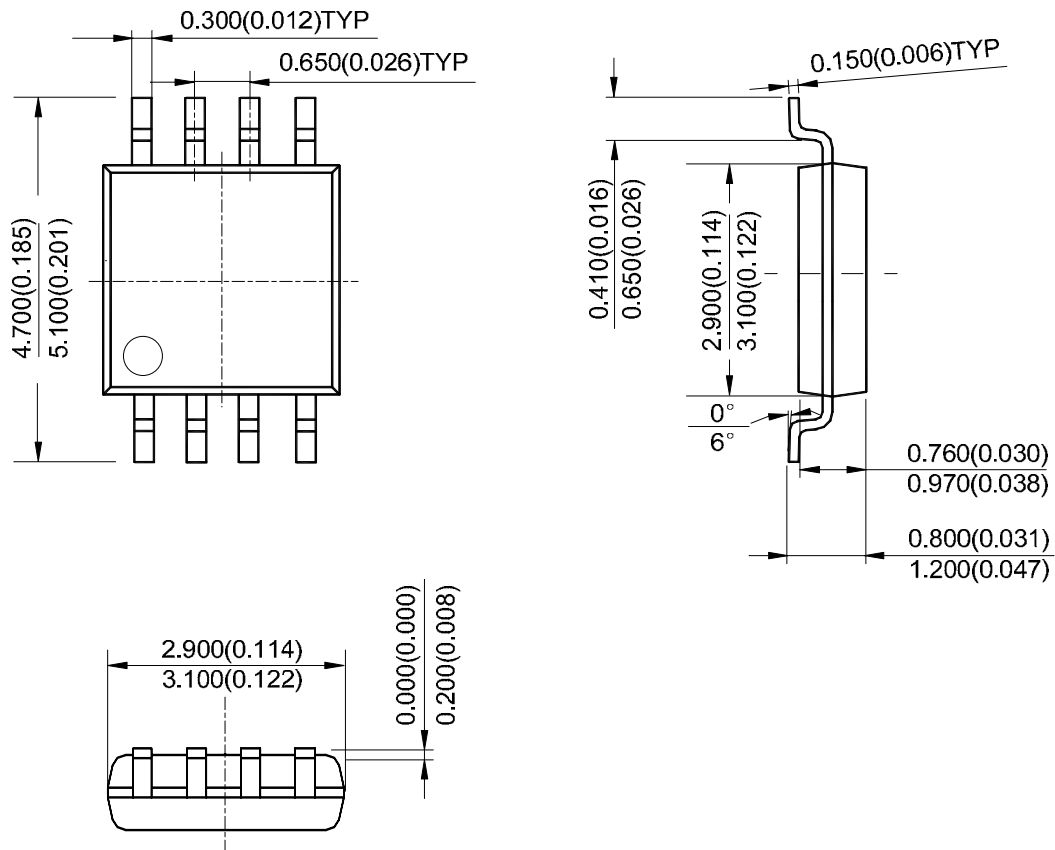
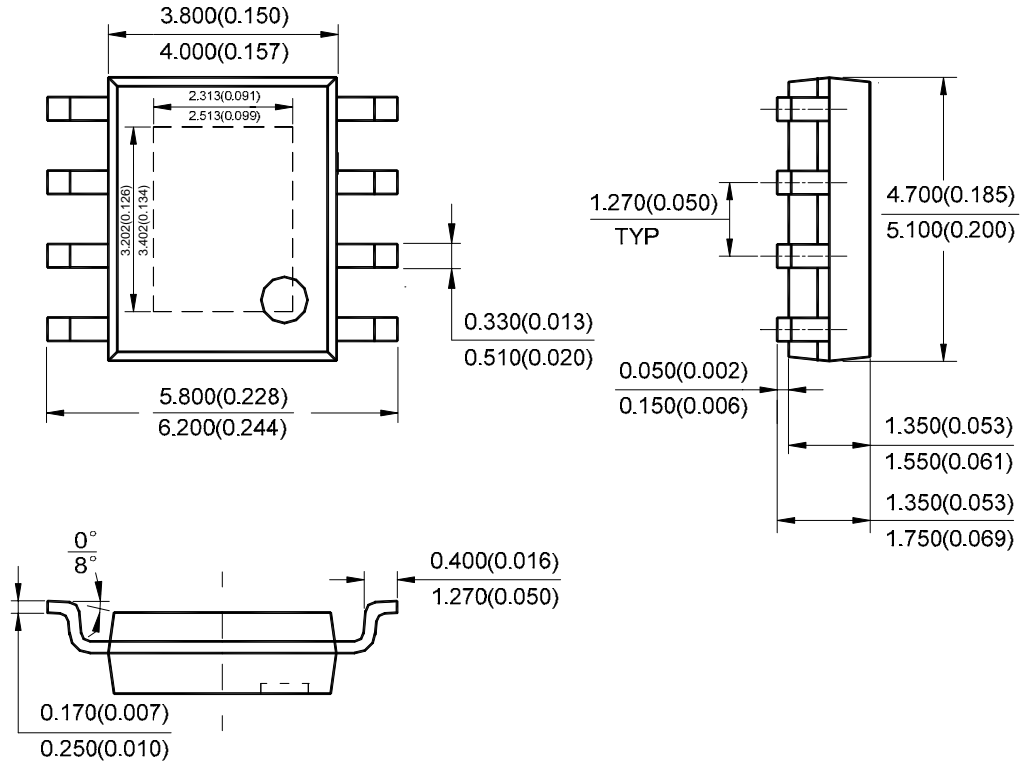

Figure 10. Typical Application of AM4952

Mechanical Dimensions
MSOP-8
Unit: mm(inch)

Note: Eject hole, oriented hole and mold mark is optional.

Mechanical Dimensions (Continued)
PSOP-8
Unit: mm(inch)

Note: Eject hole, oriented hole and mold mark is optional.

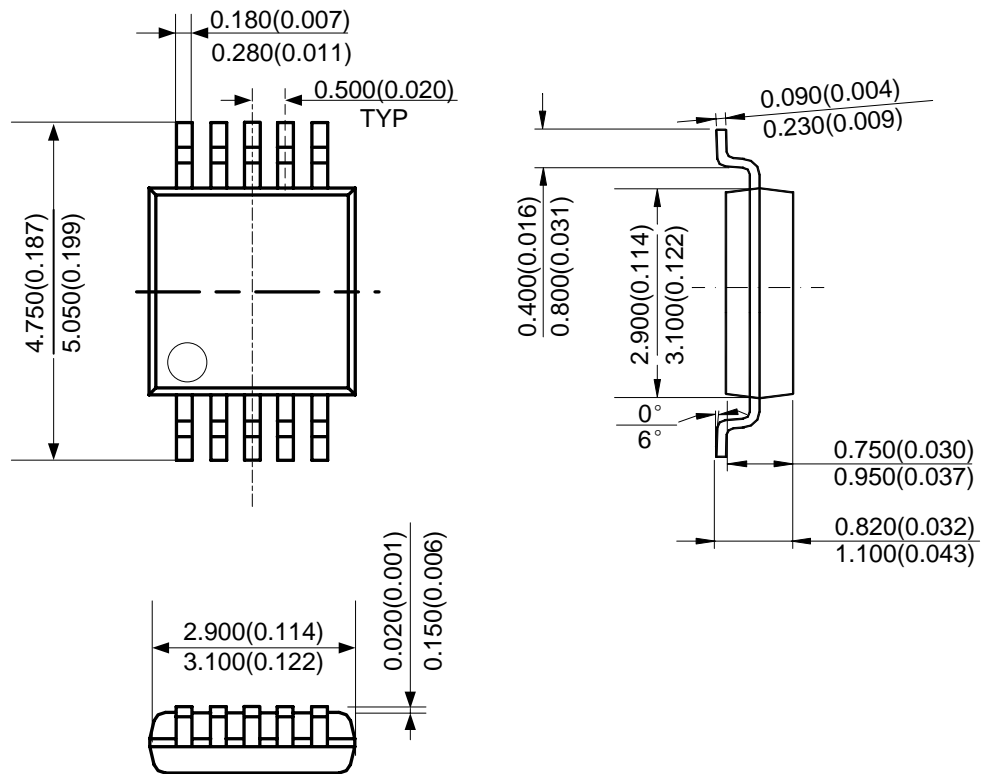
Mechanical Dimensions (Continued)
MSOP-10
Unit: mm(inch)

Note: Eject hole, oriented hole and mold mark is optional.



BCD Semiconductor Manufacturing Limited

<http://www.bcdsemi.com>

IMPORTANT NOTICE

BCD Semiconductor Manufacturing Limited reserves the right to make changes without further notice to any products or specifications herein. BCD Semiconductor Manufacturing Limited does not assume any responsibility for use of any its products for any particular purpose, nor does BCD Semiconductor Manufacturing Limited assume any liability arising out of the application or use of any its products or circuits. BCD Semiconductor Manufacturing Limited does not convey any license under its patent rights or other rights nor the rights of others.

MAIN SITE

- Headquarters
BCD Semiconductor Manufacturing Limited
No. 1600, Zi Xing Road, Shanghai Zizhu Science-based Industrial Park, 200241, China
Tel: +86-21-24162266, Fax: +86-21-24162277

- Wafer Fab
Shanghai SIM-BCD Semiconductor Manufacturing Co., Ltd.
800 Yi Shan Road, Shanghai 200233, China
Tel: +86-21-6485 1491, Fax: +86-21-5450 0008

REGIONAL SALES OFFICE

Shenzhen Office
Shanghai SIM-BCD Semiconductor Manufacturing Co., Ltd., Shenzhen Office
Unit A Room 1203, Skyworth Bldg., Gaoxin Ave.1.S., Nanshan District, Shenzhen, China
Tel: +86-755-8826 7951
Fax: +86-755-8826 7865

Taiwan Office
BCD Semiconductor (Taiwan) Company Limited
4F, 298-1, Rui Guang Road, Nei-Hu District, Taipei, Taiwan
Tel: +886-2-2656 2808
Fax: +886-2-2656 2806

USA Office
BCD Semiconductor Corp.
30920 Huntwood Ave. Hayward, CA 94544, USA
Tel: +1-510-324-2988
Fax: +1-510-324-2788