



M36L0R8060T0 M36L0R8060B0

256 Mbit (Multiple Bank, Multi-Level, Burst) Flash Memory
64 Mbit (Burst) PSRAM, 1.8V Supply, Multi-Chip Package

PRELIMINARY DATA

FEATURES SUMMARY

- MULTI-CHIP PACKAGE
 - 1 die of 256 Mbit (16Mb x16, Multiple Bank, Multi-level, Burst) Flash Memory
 - 1 die of 64 Mbit (4Mb x16) Pseudo SRAM
- SUPPLY VOLTAGE
 - $V_{DDF} = V_{CCP} = V_{DDQ} = 1.7$ to $1.95V$
 - $V_{PP} = 9V$ for fast program
- ELECTRONIC SIGNATURE
 - Manufacturer Code: 20h
 - Top Device Code
M36L0R8060T0: 880Dh
 - Bottom Device Code
M36L0R8060B0: 880Eh
- PACKAGE
 - Compliant with Lead-Free Soldering Processes
 - Lead-Free Versions

FLASH MEMORY

- SYNCHRONOUS / ASYNCHRONOUS READ
 - Synchronous Burst Read mode: 54MHz
 - Asynchronous Page Read mode
 - Random Access: 85ns
- SYNCHRONOUS BURST READ SUSPEND
- PROGRAMMING TIME
 - 10 μ s typical Word program time using Buffer Enhanced Factory Program command
- MEMORY ORGANIZATION
 - Multiple Bank Memory Array: 16 Mbit Banks
 - Parameter Blocks (Top or Bottom location)
- DUAL OPERATIONS
 - program/erase in one Bank while read in others
 - No delay between read and write operations
- SECURITY
 - 64 bit unique device number
 - 2112 bit user programmable OTP Cells

Figure 1. Package

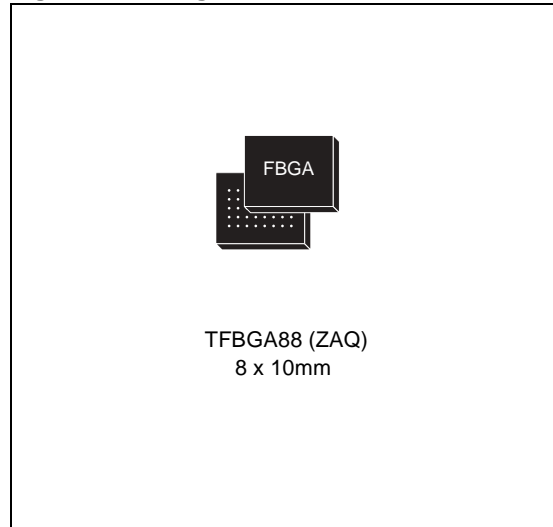

- BLOCK LOCKING
 - All blocks locked at power-up
 - Any combination of blocks can be locked with zero latency
 - WP_F for Block Lock-Down
 - Absolute Write Protection with $V_{PPF} = V_{SS}$
- COMMON FLASH INTERFACE (CFI)
- 100,000 PROGRAM/ERASE CYCLES per BLOCK
- PSRAM
 - ACCESS TIME: 70ns
 - ASYNCHRONOUS PAGE READ
 - Page Size: 16 words
 - Subsequent read within page: 20ns
 - LOW POWER FEATURES
 - Temperature Compensated Refresh (TCR)
 - Partial Array Refresh (PAR)
 - Deep Power-Down (DPD) Mode
- SYNCHRONOUS BURST READ/WRITE

TABLE OF CONTENTS

FEATURES SUMMARY 1

FLASH MEMORY 1

 Figure 1. Package. 1

PSRAM 1

SUMMARY DESCRIPTION 4

 Figure 2. Logic Diagram 4

 Table 1. Signal Names 4

 Figure 3. TFBGA Connections (Top view through package) 5

SIGNAL DESCRIPTIONS 6

 Address Inputs (A0-A23). 6

 Data Input/Output (DQ0-DQ15). 6

 Latch Enable (\overline{L}). 6

 Clock (K). 6

 Wait (WAIT). 6

 Flash Chip Enable (\overline{E}_F). 6

 Flash Output Enable (\overline{G}_F) 6

 Flash Write Enable (\overline{W}_F). 6

 Flash Write Protect (\overline{WP}_F). 6

 Flash Reset (\overline{RP}_F). 6

 PSRAM Chip Enable input (\overline{E}_P). 6

 PSRAM Write Enable (\overline{W}_P) 6

 PSRAM Output Enable (\overline{G}_P) 6

 PSRAM Upper Byte Enable (\overline{UB}_P) 7

 PSRAM Lower Byte Enable (\overline{LB}_P). 7

 PSRAM Configuration Register Enable (CR_P) 7

 V_{DDF} Supply Voltage 7

 V_{CCP} Supply Voltage. 7

 V_{DDQ} Supply Voltage. 7

 V_{PPF} Program Supply Voltage. 7

 V_{SS} Ground. 7

FUNCTIONAL DESCRIPTION 8

 Figure 4. Functional Block Diagram 8

 Table 2. Main Operating Modes 9

FLASH MEMORY DEVICES 10

PSRAM DEVICE 10

MAXIMUM RATING 11

 Table 3. Absolute Maximum Ratings 11

DC AND AC PARAMETERS	12
Table 4. Operating and AC Measurement Conditions	12
Figure 5. AC Measurement I/O Waveform	12
Figure 6. AC Measurement Load Circuit	12
Table 5. Device Capacitance	12
Table 6. Flash Memory DC Characteristics - Currents	13
Table 7. Flash Memory DC Characteristics - Voltages	14
Table 8. PSRAM DC Characteristics	14
PACKAGE MECHANICAL	15
Figure 7. TFBGA88 8x10mm, 8x10 ball array - 0.8mm pitch, Bottom View Package Outline . . .	15
Table 9. Stacked TFBGA88 8x10mm - 8x10 active ball array, 0.8mm pitch, Package Data. . . .	15
PART NUMBERING	16
Table 10. Ordering Information Scheme	16
REVISION HISTORY	17
Table 11. Document Revision History	17

SUMMARY DESCRIPTION

The M36L0R8060T0 and M36L0R8060B0 combine two memory devices in a Multi-Chip Package: a 256-Mbit, Multiple Bank Flash memory, the M30L0R8000T0 or M30L0R8000B0, and a 64-Mbit PseudoSRAM, the M69KR096A. Recommended operating conditions do not allow more than one memory to be active at the same time.

The memory is offered in a Stacked TFBGA88 (8 x 10mm, 8x10 ball array, 0.8mm pitch) package. In addition to the standard version, the packages are also available in Lead-free version, in compliance with JEDEC Std J-STD-020B, the ST ECOPACK 7191395 Specification, and the RoHS (Restriction of Hazardous Substances) directive.

All packages are compliant with Lead-free soldering processes.

The memory is supplied with all the bits erased (set to '1').

Figure 2. Logic Diagram

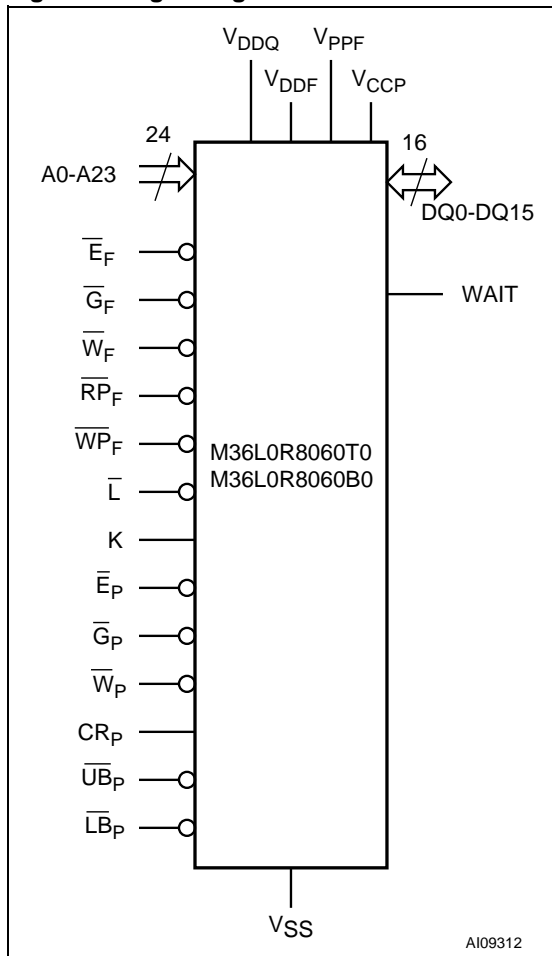
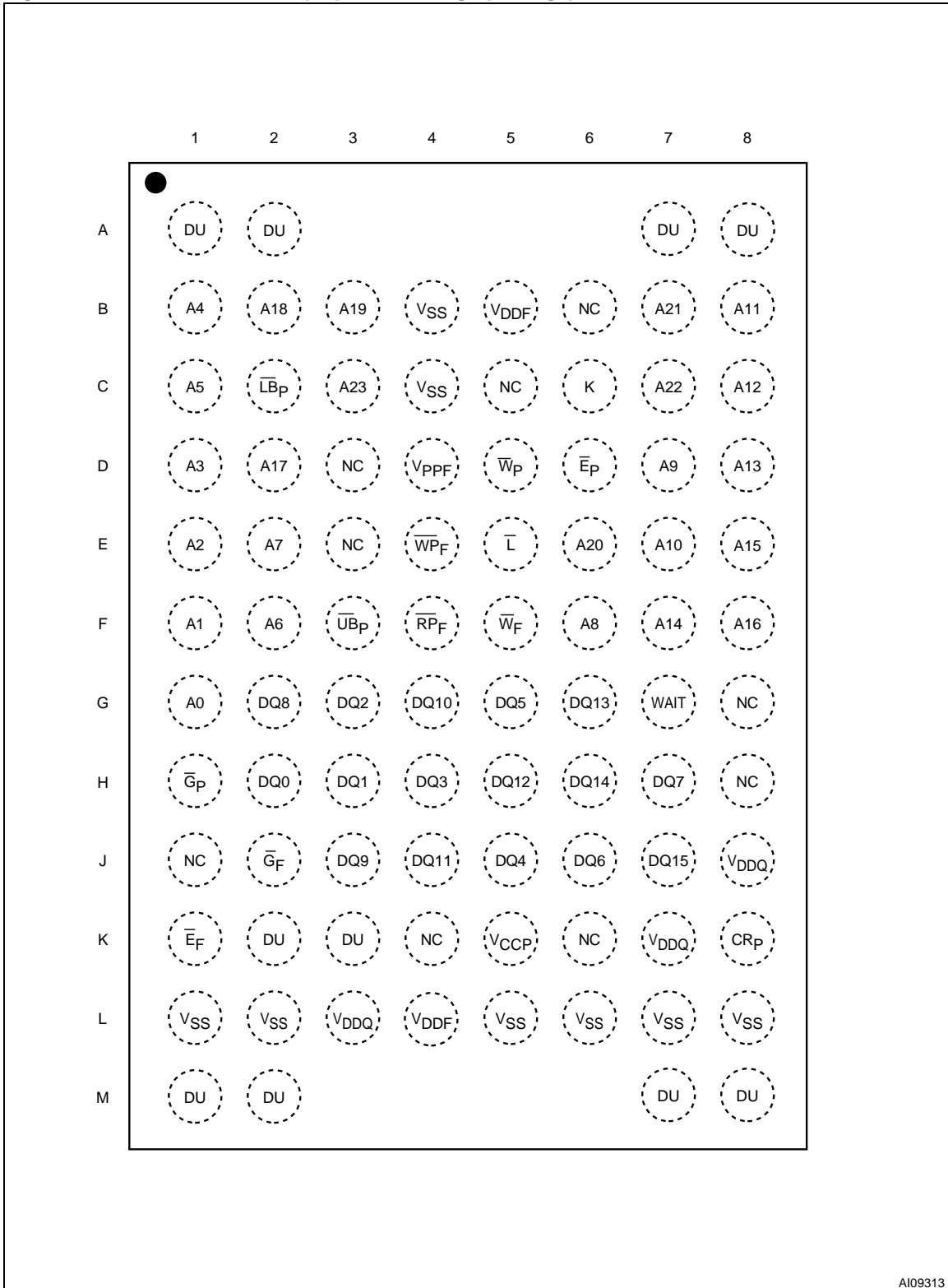

Table 1. Signal Names

A0-A23	Address Inputs
DQ0-DQ15	Common Data Input/Output
\bar{L}	Latch Enable input for Flash memory and PSRAM
K	Burst Clock for Flash memory and PSRAM
WAIT	Wait Data in Burst Mode for Flash memory and PSRAM
VDDF	Flash Memory Power Supply
VDDQ	Common Flash and PSRAM Power Supply for I/O Buffers
VPPF	Flash Optional Supply Voltage for Fast Program & Erase
VSS	Ground
VCCP	PSRAM Power Supply
NC	Not Connected Internally
DU	Do Not Use as Internally Connected
Flash Memory Signals	
\bar{E}_F	Chip Enable input
\bar{G}_F	Output Enable Input
\bar{W}_F	Write Enable input
$\bar{R}P_F$	Reset input
$\bar{W}P_F$	Write Protect input
PSRAM Signals	
\bar{E}_P	Chip Enable Input
\bar{G}_P	Output Enable Input
\bar{W}_P	Write Enable Input
CRP	Configuration Register Enable Input
$\bar{U}B_P$	Upper Byte Enable Input
$\bar{L}B_P$	Lower Byte Enable Input

Figure 3. TFBGA Connections (Top view through package)



AI09313

SIGNAL DESCRIPTIONS

See [Figure 2., Logic Diagram](#) and [Table 1., Signal Names](#), for a brief overview of the signals connected to this device.

Address Inputs (A0-A23). Addresses A0-A21 are common inputs for the Flash memory and PSRAM components. The other lines (A23-A22) are inputs for the Flash memory component only.

The Address Inputs select the cells in the memory array to access during Bus Read operations. During Bus Write operations they control the commands sent to the Command Interface of the Flash memory internal state machine or they select the cells to access in the PSRAM.

The Flash memory is accessed through the Chip Enable signal (\overline{E}_F) and through the Write Enable signal (W_F), while the PSRAM is accessed through the Chip Enable signal (\overline{E}_P) and the Write Enable signal (W_P).

Data Input/Output (DQ0-DQ15). The Data I/O output the data stored at the selected address during a Bus Read operation or input a command or the data to be programmed during a Bus Write operation.

For the PSRAM component, the upper Byte Data Inputs/Outputs (DQ8-DQ15) carry the data to or from the upper part of the selected address when Upper Byte Enable (\overline{UB}_P) is driven Low. The lower Byte Data Inputs/Outputs (DQ0-DQ7) carry the data to or from the lower part of the selected address when Lower Byte Enable (\overline{LB}_P) is driven Low. When both \overline{UB}_P and \overline{LB}_P are disabled, the Data Inputs/Outputs are high impedance.

Latch Enable (L). The Latch Enable pin is common to the Flash memory and PSRAM components.

For details of how the Latch Enable signal behaves, please refer to the datasheets of the respective memory components: M69KR096A for the PSRAM and M30L0R8000T/B0 for the Flash memory.

Clock (K). The Clock input pin is common to the Flash memory and PSRAM components.

For details of how the Clock signal behaves, please refer to the datasheets of the respective memory components: M69KR096A for the PSRAM and M30L0R8000T/B0 for the Flash memory.

Wait (WAIT). WAIT is an output pin common to the Flash memory and PSRAM components. However the WAIT signal does not behave in the same way for the PSRAM and the Flash memory.

For details of how it behaves, please refer to the M69KR096A datasheet for the PSRAM and to the M30L0R8000T/B0 datasheet for the Flash memory.

Flash Chip Enable (\overline{E}_F). The Flash Chip Enable input activates the control logic, input buffers, decoders and sense amplifiers of the Flash memory component. When Chip Enable is Low, V_{IL} , and Reset is High, V_{IH} , the device is in active mode. When Chip Enable is at V_{IH} the Flash memory is deselected, the outputs are high impedance and the power consumption is reduced to the standby level.

Flash Output Enable (\overline{G}_F). The Output Enable pin controls the data outputs during Flash memory Bus Read operations.

Flash Write Enable (\overline{W}_F). The Write Enable controls the Bus Write operation of the Flash memories' Command Interface. The data and address inputs are latched on the rising edge of Chip Enable or Write Enable whichever occurs first.

Flash Write Protect (\overline{WP}_F). Write Protect is an input that gives an additional hardware protection for each block. When Write Protect is Low, V_{IL} , Lock-Down is enabled and the protection status of the Locked-Down blocks cannot be changed. When Write Protect is at High, V_{IH} , Lock-Down is disabled and the Locked-Down blocks can be locked or unlocked. (See the Lock Status Table in the M30L0R8000T/B0 datasheet).

Flash Reset (\overline{RP}_F). The Reset input provides a hardware reset of the Flash memory. When Reset is at V_{IL} , the memory is in Reset mode: the outputs are high impedance and the current consumption is reduced to the Reset Supply Current I_{DD2} . Refer to [Table 6., Flash Memory DC Characteristics - Currents](#), for the value of I_{DD2} . After Reset all blocks are in the Locked state and the Configuration Register is reset. When Reset is at V_{IH} , the device is in normal operation. Exiting Reset mode the device enters Asynchronous Read mode, but a negative transition of Chip Enable or Latch Enable is required to ensure valid data outputs.

The Reset pin can be interfaced with 3V logic without any additional circuitry. It can be tied to V_{RPH} (refer to [Table 7., Flash Memory DC Characteristics - Voltages](#)).

PSRAM Chip Enable input (\overline{E}_P). The Chip Enable input activates the PSRAM when driven Low (asserted). When deasserted (V_{IH}), the device is disabled, and goes automatically in low-power Standby mode or Deep Power-down mode.

PSRAM Write Enable (\overline{W}_P). Write Enable, \overline{W}_P , controls the Bus Write operation of the PSRAM. When asserted (V_{IL}), the device is in Write mode and Write operations can be performed either to the configuration registers or to the memory array.

PSRAM Output Enable (\overline{G}_P). Output Enable, \overline{G}_P , provides a high speed tri-state control, allow-

ing fast read/write cycles to be achieved with the common I/O data bus.

PSRAM Upper Byte Enable (\overline{UBP}). The Upper Byte Enable, \overline{UBP} , gates the data on the Upper Byte Data Inputs/Outputs (DQ8-DQ15) to or from the upper part of the selected address during a Write or Read operation.

PSRAM Lower Byte Enable (\overline{LBP}). The Lower Byte Enable, \overline{LBP} , gates the data on the Lower Byte Data Inputs/Outputs (DQ0-DQ7) to or from the lower part of the selected address during a Write or Read operation.

If both \overline{LBP} and \overline{UBP} are disabled (High) during an operation, the device will disable the data bus from receiving or transmitting data. Although the device will seem to be deselected, it remains in an active mode as long as E_P remains Low.

PSRAM Configuration Register Enable (CR_P).

When this signal is driven High, V_{IH} , Write operations load either the value of the Refresh Configuration Register (RCR) or the Bus configuration register (BCR).

V_{DDF} Supply Voltage. V_{DDF} provides the power supply to the internal core of the Flash memory. It is the main power supply for all Flash memory operations (Read, Program and Erase).

V_{CCP} Supply Voltage. V_{CCP} provides the power supply to the internal core of the PSRAM device. It is the main power supply for all PSRAM operations.

V_{DDQ} Supply Voltage. V_{DDQ} provides the power supply for the Flash and PSRAM I/O pins. This allows all Outputs to be powered independently of

the Flash and SRAM core power supplies, V_{DDF} and V_{CCP} .

V_{PPF} Program Supply Voltage. V_{PPF} is both a Flash control input and a Flash power supply pin. The two functions are selected by the voltage range applied to the pin.

If V_{PPF} is kept in a low voltage range (0V to V_{DDQ}) V_{PPF} is seen as a control input. In this case a voltage lower than V_{PPLK} gives an absolute protection against Program or Erase, while $V_{PPF} > V_{PP1}$ enables these functions (see Tables 6 and 7, DC Characteristics for the relevant values). V_{PPF} is only sampled at the beginning of a Program or Erase; a change in its value after the operation has started does not have any effect and Program or Erase operations continue.

If V_{PPF} is in the range of V_{PPH} it acts as a power supply pin. In this condition V_{PPF} must be stable until the Program/Erase algorithm is completed.

V_{SS} Ground. V_{SS} is the common ground reference for all voltage measurements in the Flash (core and I/O Buffers) and PSRAM chips. It must be connected to the system ground.

Note: Each Flash memory device in a system should have their supply voltage (V_{DDF}) and the program supply voltage V_{PPF} decoupled with a 0.1 μ F ceramic capacitor close to the pin (high frequency, inherently low inductance capacitors should be as close as possible to the package). See Figure 6., AC Measurement Load Circuit. The PCB track widths should be sufficient to carry the required V_{PPF} program and erase currents.

FUNCTIONAL DESCRIPTION

The PSRAM and Flash memory components have separate power supplies but share the same grounds. They are distinguished by two Chip Enable inputs: \bar{E}_F for the Flash memory and \bar{E}_P for the PSRAM.

Recommended operating conditions do not allow more than one device to be active at a time. The

most common example is simultaneous read operations on one of the Flash and the PSRAM which would result in a data bus contention. Therefore it is recommended to put the other devices in the high impedance state when reading the selected device.

Figure 4. Functional Block Diagram

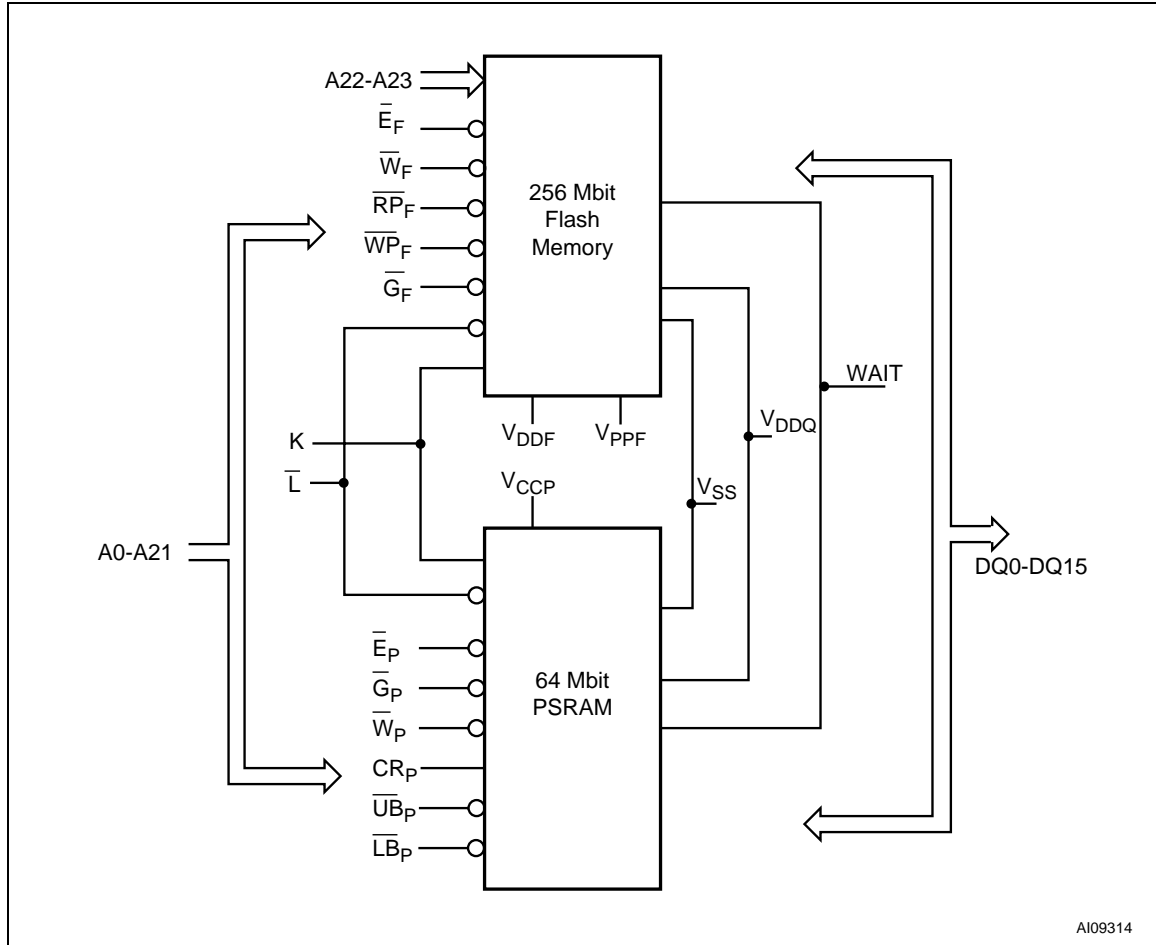

Table 2. Main Operating Modes

Operation	\overline{E}_F	\overline{G}_F	\overline{W}_F	\overline{L}_F	\overline{R}_P	WAIT _F ⁽⁴⁾	\overline{E}_P	CR _P	\overline{G}_P	\overline{W}_P	$\overline{L}_P, \overline{U}_P$	DQ15-DQ0
Flash Read	V _{IL}	V _{IL}	V _{IH}	V _{IL} ⁽²⁾	V _{IH}		PSRAM must be disabled.					Flash Data Out
Flash Write	V _{IL}	V _{IH}	V _{IL}	V _{IL} ⁽²⁾	V _{IH}							Flash Data In
Flash Address Latch	V _{IL}	X	V _{IH}	V _{IL}	V _{IH}							Flash Data Out or Hi-Z ⁽³⁾
Flash Output Disable	V _{IL}	V _{IH}	V _{IH}	X	V _{IH}		Any PSRAM mode is allowed.					Hi-Z
Flash Standby	V _{IH}	X	X	X	V _{IH}	Hi-Z						Hi-Z
Flash Reset	X	X	X	X	V _{IL}	Hi-Z						Hi-Z
PSRAM Read	The Flash memory must be disabled						V _{IL}	V _{IL}	V _{IL}	V _{IH}	V _{IL}	PSRAM data out
PSRAM Write							V _{IL}	V _{IL}	X	V _{IL}	V _{IL}	PSRAM data in
PSRAM Write Configuration Register							V _{IL}	V _{IH}	V _{IH}	V _{IL}	X	PSRAM data in
PSRAM Standby	Any Flash mode is allowed.						V _{IH}	V _{IL}	X	X	X	Hi-Z
PSRAM Deep Power-Down							V _{IH}	X	X	X	X	Hi-Z

Note: 1. X = Don't care.

2. L_F can be tied to V_{IH} if the valid address has been previously latched.

3. Depends on G_F.

4. WAIT signal polarity is configured using the Set Configuration Register command. See the M30L0R8000T0 datasheet for details.

M36L0R8060T0, M36L0R8060B0

FLASH MEMORY DEVICES

The M36L0R8060T0 and M36L0R8060B0 contain a 256 Mbit Flash memory. For detailed information on how to use the device, refer to the

M30L0R8000(T/B)0 datasheet which is available from your local STMicroelectronics distributor.

PSRAM DEVICE

The M36L0R8060T0 and M36L0R8060B0 contain a 64Mbit PSRAM. For detailed information on how to use the device, see the M69KR096A datasheet

which is available from your local STMicroelectronics distributor.

MAXIMUM RATING

Stressing the device above the rating listed in the Absolute Maximum Ratings table may cause permanent damage to the device. These are stress ratings only and operation of the device at these or any other conditions above those indicated in the Operating sections of this specification is not im-

plied. Exposure to Absolute Maximum Rating conditions for extended periods may affect device reliability. Refer also to the STMicroelectronics SURE Program and other relevant quality documents.

Table 3. Absolute Maximum Ratings

Symbol	Parameter	Value		Unit
		Min	Max	
T _A	Ambient Operating Temperature	-25	85	°C
T _{BIAS}	Temperature Under Bias	-25	85	°C
T _{STG}	Storage Temperature	-65	125	°C
T _{LEAD}	Lead Temperature during Soldering		(1)	°C
V _{IO}	Input or Output Voltage	-0.5	2.75	V
V _{DDF} , V _{DDQ} , V _{CCP}	Core and Input/Output Supply Voltages	-0.2	2.45	V
V _{PPF}	Flash Program Voltage	-0.2	10	V
I _O	Output Short Circuit Current		100	mA
t _{VPPFH}	Time for V _{PPF} at V _{PPFH}		100	hours

Note: 1. Compliant with the JEDEC Std J-STD-020B (for small body, Sn-Pb or Pb assembly), the ST ECOPACK[®] 7191395 specification, and the European directive on Restrictions on Hazardous Substances (RoHS) 2002/95/EU.

DC AND AC PARAMETERS

This section summarizes the operating measurement conditions, and the DC and AC characteristics of the device. The parameters in the DC and AC characteristics Tables that follow, are derived from tests performed under the Measurement

Conditions summarized in [Table 4., Operating and AC Measurement Conditions](#). Designers should check that the operating conditions in their circuit match the operating conditions when relying on the quoted parameters.

Table 4. Operating and AC Measurement Conditions

Parameter	Flash Memory		PSRAM		Unit
	Min	Max	Min	Max	
V _{DDF} Supply Voltage	1.7	1.95	–	–	V
V _{CCP} Supply Voltage	–	–	1.7	1.95	V
V _{DDQ} Supply Voltage	1.7	1.95	1.7	1.95	V
V _{PPF} Supply Voltage (Factory environment)	8.5	9.5	–	–	V
V _{PPF} Supply Voltage (Application environment)	–0.4	V _{DDQ} +0.4	–	–	V
Ambient Operating Temperature	–25	85	–25	85	°C
Load Capacitance (C _L)	30		30		pF
Output Circuit Resistors (R ₁ , R ₂)	16.7		16.7		kΩ
Input Rise and Fall Times		5			ns
Input Pulse Voltages	0 to V _{DDQ}		0 to V _{DDQ}		V
Input and Output Timing Ref. Voltages	V _{DDQ} /2		V _{DDQ} /2		V

Figure 5. AC Measurement I/O Waveform

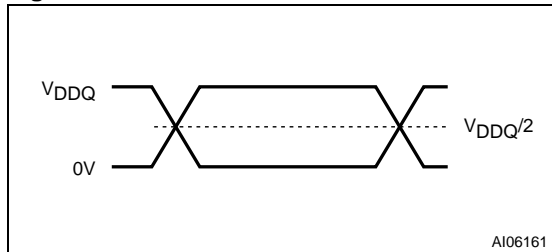

Figure 6. AC Measurement Load Circuit

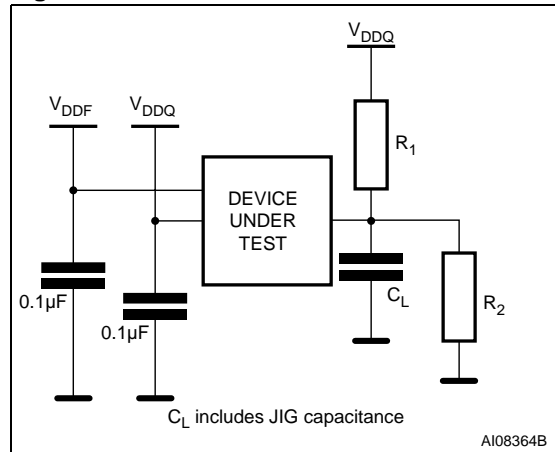

Table 5. Device Capacitance

Symbol	Parameter	Test Condition	Min	Max	Unit
C _{IN}	Input Capacitance	V _{IN} = 0V		14	pF
C _{OUT}	Output Capacitance	V _{OUT} = 0V		18	pF

Note: Sampled only, not 100% tested.

Table 6. Flash Memory DC Characteristics - Currents

Symbol	Parameter	Test Condition	Typ	Max	Unit
I _{LI}	Input Leakage Current	$0V \leq V_{IN} \leq V_{DDQ}$		±1	µA
I _{LO}	Output Leakage Current	$0V \leq V_{OUT} \leq V_{DDQ}$		±1	µA
I _{DD1}	Supply Current Asynchronous Read (f=5MHz)	$\bar{E}_F = V_{IL}, \bar{G}_F = V_{IH}$	13	15	mA
		4 Word	16	18	mA
	Supply Current Synchronous Read (f=54MHz)	8 Word	18	20	mA
		16 Word	23	25	mA
		Continuous	25	27	mA
I _{DD2}	Supply Current (Reset)	$\overline{RPF} = V_{SS} \pm 0.2V$	50	110	µA
I _{DD3}	Supply Current (Standby)	$\bar{E}_F = V_{DDF} \pm 0.2V$	50	110	µA
I _{DD4}	Supply Current (Automatic Standby)	$\bar{E}_F = V_{IL}, \bar{G}_F = V_{IH}$	50	110	µA
I _{DD5} ⁽¹⁾	Supply Current (Program)	$V_{PPF} = V_{PPH}$	8	15	mA
		$V_{PPF} = V_{DDF}$	10	20	mA
	Supply Current (Erase)	$V_{PPF} = V_{PPH}$	8	15	mA
		$V_{PPF} = V_{DDF}$	10	20	mA
I _{DD6} ^(1,2)	Supply Current (Dual Operations)	Program/Erase in one Bank, Asynchronous Read in another Bank	23	35	mA
		Program/Erase in one Bank, Synchronous Read (Continuous f=54MHz) in another Bank	35	47	mA
I _{DD7} ⁽¹⁾	Supply Current Program/ Erase Suspended (Standby)	$\bar{E}_F = V_{DDF} \pm 0.2V$	50	110	µA
I _{PP1} ⁽¹⁾	V _{PPF} Supply Current (Program)	$V_{PPF} = V_{PPH}$	2	5	mA
		$V_{PPF} = V_{DDF}$	0.2	5	µA
	V _{PPF} Supply Current (Erase)	$V_{PPF} = V_{PPH}$	2	5	mA
		$V_{PPF} = V_{DDF}$	0.2	5	µA
I _{PP2}	V _{PPF} Supply Current (Read)	$V_{PPF} \leq V_{DDF}$	0.2	5	µA
I _{PP3} ⁽¹⁾	V _{PPF} Supply Current (Standby)	$V_{PPF} \leq V_{DDF}$	0.2	5	µA

Note: 1. Sampled only, not 100% tested.

2. V_{DDF} Dual Operation current is the sum of read and program or erase currents.

3. The total standby current should be calculated as the sum of the Flash memory standby current plus the PSRAM standby current.

M36L0R8060T0, M36L0R8060B0

Table 7. Flash Memory DC Characteristics - Voltages

Symbol	Parameter	Test Condition	Min	Typ	Max	Unit
V _{IL}	Input Low Voltage		0		0.4	V
V _{IH}	Input High Voltage		V _{DDQ} - 0.4		V _{DDQ} + 0.4	V
V _{OL}	Output Low Voltage	I _{OL} = 100μA			0.1	V
V _{OH}	Output High Voltage	I _{OH} = -100μA	V _{DDQ} - 0.1			V
V _{PP1}	V _{PPF} Program Voltage-Logic	Program, Erase	1.1	1.8	3.3	V
V _{PPH}	V _{PPF} Program Voltage Factory	Program, Erase	8.5	9.0	9.5	V
V _{PPLK}	Program or Erase Lockout				0.4	V
V _{LKO}	V _{DDF} Lock Voltage		1			V
V _{RPH}	$\overline{\text{RPF}}$ pin Extended High Voltage				3.3	V

Table 8. PSRAM DC Characteristics

Symbol	Parameter	Test Condition	Min.	Typ	Max.	Unit
I _{CC1} ⁽¹⁾	Operating Current: Asynchronous Random Read/Write	V _{CCP} = V _{IH} or V _{IL} , E _P = V _{IL} , I _{OUT} = 0mA	70ns		25	mA
			85ns		20	mA
I _{CC1P} ⁽¹⁾	Operating Current: Asynchronous Page Read		70ns		15	mA
			85ns		12	mA
I _{CC2} ⁽¹⁾	Operating Current: Initial Access, Burst Read/Write		104MHz		35	mA
			80MHz		35	mA
			66MHz		30	mA
I _{CC3R} ⁽¹⁾	Operating Current: Continuous Burst Read		104MHz		20	mA
			80MHz		18	mA
			66MHz		15	mA
I _{CC3W} ⁽¹⁾	Operating Current: Continuous Burst Write	104MHz		35	mA	
		80MHz		35	mA	
		66MHz		30	mA	
I _{SB} ⁽³⁾	V _{CC} Standby Current	V _{CCP} = V _{DDQ} or 0V, E _P = V _{IL}			100	μA
I _{LI}	Input Leakage Current	0V ≤ V _{IN} ≤ V _{CCP}			1	μA
I _{LO} ²	Output Leakage Current	0V ≤ V _{OUT} ≤ V _{CCP}			1	μA
I _{ZZ}	Deep-Power Down Current	V _{IN} = V _{IH} or V _{IL} ⁴		10		μA
V _{IH}	Input High Voltage		1.4		V _{DDQ} + 0.2	V
V _{IL}	Input Low Voltage		-0.2		0.4	V
V _{OH}	Output High Voltage	I _{OH} = -0.2mA	0.8V _{DDQ}			V
V _{OL}	Output Low Voltage	I _{OL} = 0.2mA			0.2V _{DDQ}	V

- Note: 1. This parameter is specified with the outputs disabled to avoid external loading effects. The user must add the current required to drive the output capacitance expected in the actual system.
2. This device assumes a Standby mode if the chip is disabled (E_P High). It also automatically goes into Standby mode whenever all input signals are quiescent (not toggling), regardless of the state of E. In order to achieve low standby current, all inputs must be driven to either V_{DDQ} or V_{SS}.
3. I_{SB}(Max) values are measured with RCR2 to RCR0 bits set to '000' (full array refresh) and RCR6 to RCR5 bits set to '11' (temperature compensated refresh threshold at +85°C).
4. Operating Temperature is +25°C.

PACKAGE MECHANICAL

Figure 7. TFBGA88 8x10mm, 8x10 ball array - 0.8mm pitch, Bottom View Package Outline

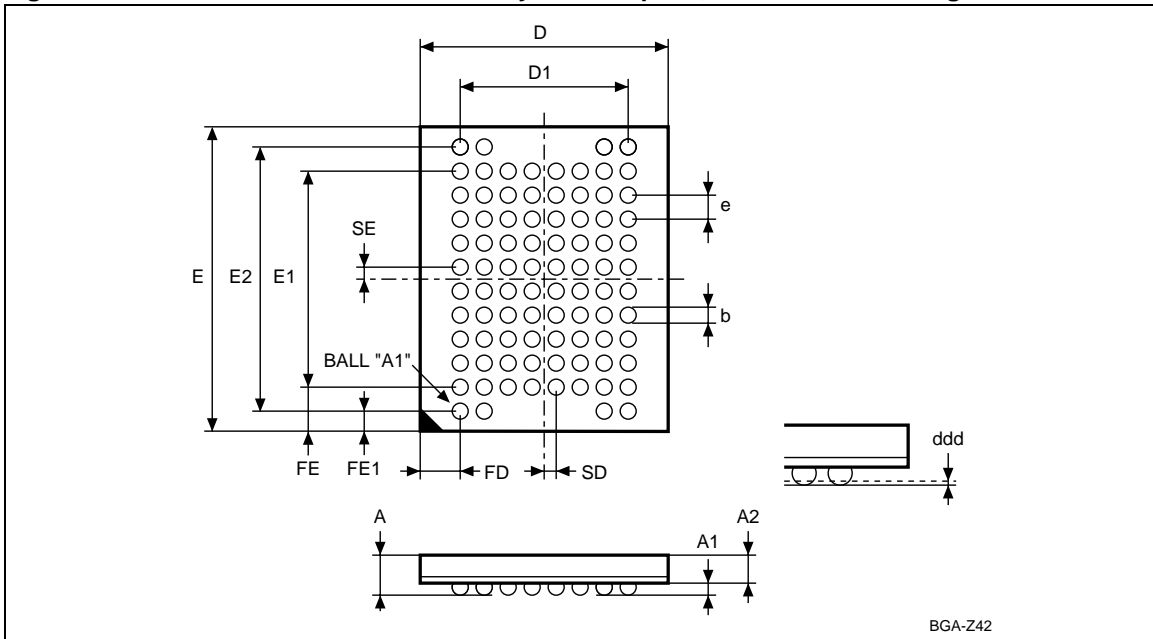

Note: Drawing is not to scale.

Table 9. Stacked TFBGA88 8x10mm - 8x10 active ball array, 0.8mm pitch, Package Data

Symbol	millimeters			inches		
	Typ	Min	Max	Typ	Min	Max
A			1.200			0.0472
A1		0.200			0.0079	
A2	0.850			0.0335		
b	0.350	0.300	0.400	0.0138	0.0118	0.0157
D	8.000	7.900	8.100	0.3150	0.3110	0.3189
D1	5.600			0.2205		
ddd			0.100			0.0039
E	10.000	9.900	10.100	0.3937	0.3898	0.3976
E1	7.200			0.2835		
E2	8.800			0.3465		
e	0.800	-	-	0.0315	-	-
FD	1.200			0.0472		
FE	1.400			0.0551		
FE1	0.600			0.0236		
SD	0.400			0.0157		
SE	0.400			0.0157		

PART NUMBERING

Table 10. Ordering Information Scheme

Example:

M36 L 0 R 8 0 6 0 T 0 ZAQ T

Device Type

M36 = Multi-Chip Package (Flash + RAM)

Flash 1 Architecture

L = Multilevel, Multiple Bank, Burst mode

Flash 2 Architecture

0 = No Die

Operating Voltage

R = $V_{DDF} = V_{CCP} = V_{DDQ} = 1.7$ to $1.95V$

Flash 1 Density

8 = 256 Mbits

Flash 2 Density

0 = No Die

RAM 1 Density

6 = 64 Mbits

RAM 0 Density

0 = No Die

Parameter Blocks Location

T = Top Boot Block Flash

B = Bottom Boot Block Flash

Product Version

0 = $0.13\mu m$ Flash Technology Multi-Level Design, 85ns speeds;
 0.11 μm PSRAM, 70ns speed, burst mode

Package

ZAQ = Stacked TFBGA88 8x10mm - 8x10 active ball array, 0.8mm pitch

Option

Blank = Standard Packing

T = Tape & Reel Packing

E = Lead-free and RoHS Standard packing

F = Lead-free and RoHS Tape & Reel packing

Devices are shipped from the factory with the memory content bits erased to '1'. For a list of available options (Speed, Package, etc.) or for further information on any aspect of this device, please contact the ST-Microelectronics Sales Office nearest to you.

REVISION HISTORY**Table 11. Document Revision History**

Date	Version	Revision Details
29-Jan-2004	0.1	First Issue
09-Dec-2004	1.0	TFBGA88 package fully compliant with the ST ECOPACK specification. Document status promoted from Target Specification to Preliminary Data. Flash memory and PSRAM data updated to the version 0.3 of the M30L0R8000x0 and to the version 3.0 of the M69KR096A datasheet.

Information furnished is believed to be accurate and reliable. However, STMicroelectronics assumes no responsibility for the consequences of use of such information nor for any infringement of patents or other rights of third parties which may result from its use. No license is granted by implication or otherwise under any patent or patent rights of STMicroelectronics. Specifications mentioned in this publication are subject to change without notice. This publication supersedes and replaces all information previously supplied. STMicroelectronics products are not authorized for use as critical components in life support devices or systems without express written approval of STMicroelectronics.

The ST logo is a registered trademark of STMicroelectronics.
ECOPACK is a registered trademark of STMicroelectronics.
All other names are the property of their respective owners

© 2004 STMicroelectronics - All rights reserved

STMicroelectronics group of companies
Australia - Belgium - Brazil - Canada - China - Czech Republic - Finland - France - Germany - Hong Kong - India - Israel - Italy - Japan -
Malaysia - Malta - Morocco - Singapore - Spain - Sweden - Switzerland - United Kingdom - United States of America
www.st.com