

Features

- 64-Mbit Flash and 16-Mbit PSRAM
- Single 66-ball (8 mm x 10 mm x 1.2 mm) CBGA Package
- 2.7V to 3.1V Operating Voltage

Flash



- Single Voltage Read/Write Operation: 2.65V to 3.6V
- Access Time – 70 ns
- Sector Erase Architecture
 - One Hundred Twenty-seven 32K Word Sectors with Individual Write Lockout
 - Eight 4K Word Sectors with Individual Write Lockout
- Fast Word Program Time – 10 μ s
- Typical Sector Erase Time: 32K Word Sectors – 700 ms; 4K Word Sectors – 100 ms
- Suspend/Resume Feature for Erase and Program
 - Supports Reading and Programming Data from Any Sector by Suspending Erase of a Different Sector
 - Supports Reading Any Word by Suspending Programming of Any Other Word
- Low-power Operation
 - 10 mA Active
 - 15 μ A Standby
- VPP Pin for Write Protection and Accelerated Program Operation
- WP Pin for Sector Protection
- RESET Input for Device Initialization
- Flexibel Sector Protection
- Top or Bottom Boot Block Configuration Available
- 128-bit Protection Register
- Minimum 100,000 Erase Cycles
- Common Flash Interface (CFI)

PSRAM

- 16-megabit (1M x 16)
- 2.7V to 3.1V V_{CC}
- 70 ns Access Time

Device Number	Flash Boot Location	Flash Plane Configuration	PSRAM Configuration
AT52BC6402D	Bottom	64M (4M x 16)	16M (1M x 16)
AT52BC6402DT	Top	64M (4M x 16)	16M (1M x 16)

Flash & PSRAM Datasheets

Datasheets	PDF File
64M Flash Memory: AT49BV640D(T)	 Acrobat Document
16M PSRAM: 2FHY64UD16161B	 Acrobat Document



**64-megabit
Flash +
16-megabit
PSRAM
Stack Memory**

**AT52BC6402D
AT52BC6402DT**

Preliminary



1. Pin Configuration

Pin Name	Function
A0 - A19, A21	Common Address Input for 16M PSRAM/Flash, Flash Address Input
\overline{CE}	Flash Chip Enable
\overline{OE}	Flash Output Enable
\overline{WE}	Flash Write Enable
\overline{RESET}	Flash Reset
\overline{PW}	Flash Write Protect
VPP	Flash Power Supply for Accelerated Program Operation
VCC	Flash Power
GND	Flash Ground
I/O0 - I/O15	Data Inputs/Outputs
NC	No Connect
\overline{LB}	PSRAM Lower Byte
\overline{UB}	PSRAM Upper Byte
PVCC	PSRAM Power
PGND	PSRAM Ground
$\overline{PCS1}$	PSRAM Chip Select 1
PCS2	Low Power Modes
\overline{PWE}	PSRAM Write Enable
\overline{POE}	PSRAM Output Enable

2. AT52BC6402D(T) (Top View)

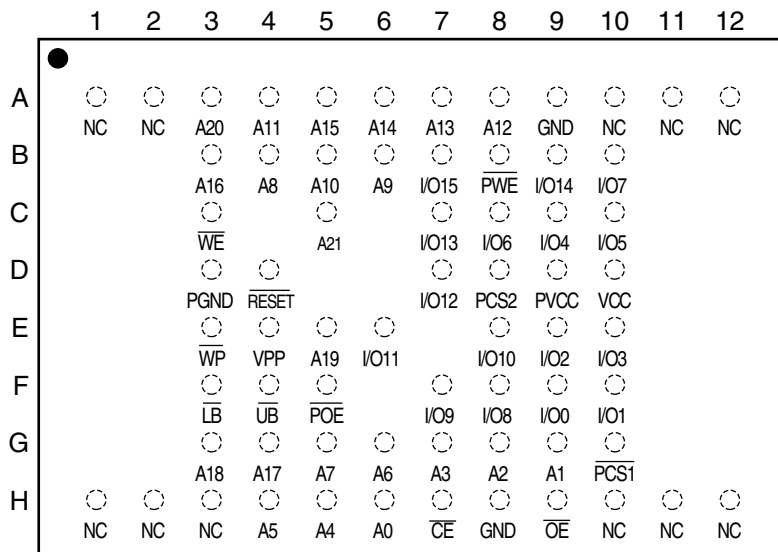

3. Block Diagram

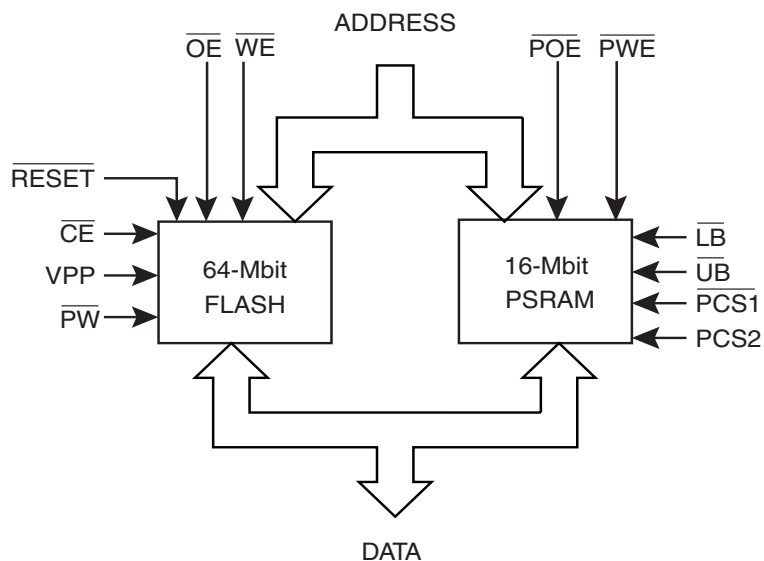

4. Description

The AT52BC6402D(T) combines a 64-megabit Flash (4M x 16) and an 16-megabit PSRAM (organized as 1M x 16) in a stacked 66-ball CBGA package. The stacked modules operate at 2.7V to 3.1V in the extended temperature range.

5. Absolute Maximum Ratings

Temperature under Bias	-55°C to +85°C
Storage Temperature	-55°C to +150°C
All Input Voltages except V_{PP} (including NC Pins) with Respect to Ground	-0.2V to $V_{CC} + 0.3V$
Voltage on V_{PP} with Respect to Ground	-0.2V to + 10.0V
All Output Voltages with Respect to Ground	-0.2V to $V_{CC} + 0.3V$

***NOTICE:** Stresses beyond those listed under “Absolute Maximum Ratings” may cause permanent damage to the device. This is a stress rating only and functional operation of the device at these or any other conditions beyond those indicated in the operational sections of this specification is not implied. Exposure to absolute maximum rating conditions for extended periods may affect device reliability.

6. DC and AC Operating Range

	AT52BC6402D(T)-70CU
Operating Temperature (Case)	-30°C - 85°C
V_{CC} Power Supply	2.7V to 3.1V

7. Flash Operating Modes

Mode	\overline{CE}	\overline{OE}	\overline{WE}	\overline{RESET}	$V_{PP}^{(2)}$	Ai	I/O	PSRAM Operation
Read	V_{IL}	V_{IL}	V_{IH}	V_{IH}	X	Ai	D_{OUT}	PSRAM Must Be High-Z
Program/Erase	V_{IL}	V_{IH}	V_{IL}	V_{IH}	$V_{IHPP}^{(3)}$	Ai	D_{IN}	
Program Inhibit	V_{IL}	X	V_{IH}	V_{IH}	X			
	V_{IL}	X	X	X	$V_{ILPP}^{(4)}$			
Software Product Identification	V_{IL}	V_{IL}	V_{IH}	V_{IH}	X	$A0 = V_{IL}, A1 - A19 = V_{IL}$	Manufacturer Code	
						$A0 = V_{IH}, A1 - A19 = V_{IL}$	Device Code	
Standby/Program Inhibit	V_{IH}	$X^{(1)}$	X	V_{IH}	X	X	High Z	Any PSRAM Operation is Allowed
Output Disable	X	V_{IH}	X	V_{IH}	X		High Z	
Reset	X	X	X	V_{IL}	X	X	High Z	

- Notes:
1. X can be V_{IL} or V_{IH}
 2. The V_{PP} pin can be tied to V_{CC} . For faster program operations, V_{PP} can be set to $9.5V \pm 0.5V$.
 3. $V_{IHPP} \text{ (min)} = 1.65V$
 4. $V_{ILPP} \text{ (max)} = 0.4V$

8. Functional Description

$\overline{PCS1}$	PCS2	\overline{POE}	\overline{PWE}	\overline{LB}	\overline{UB}	I/O0 - 7	I/O8 - 15	Mode	Power	Flash Operation
H	H	$X^{(1)}$	$X^{(1)}$	$X^{(1)}$	$X^{(1)}$	High-Z	High-Z	Deselected	Standby	Any Flash Operation Allowed
$X^{(1)}$	L	$X^{(1)}$	$X^{(1)}$	$X^{(1)}$	$X^{(1)}$	High-Z	High-Z	Deselected	Low-power Modes	
$L^{(1)}$	H	$X^{(1)}$	$X^{(1)}$	H	H	High-Z	High-Z	Output Disabled	Active	Flash Must Be High Z
L	H	H	H	L	$X^{(1)}$	High-Z	High-Z	Output Disabled	Active	
	H	H	H	$X^{(1)}$	L	High-Z	High-Z	Output Disabled	Active	
L	H	L	H	L	H	D_{OUT}	High-Z	Lower Byte Read	Active	
				H	L	High-Z	D_{OUT}	Upper Byte Read	Active	
				L	L	D_{OUT}	D_{OUT}	Word Read	Active	
		$X^{(1)}$	L	L	H	D_{IN}	High-Z	Lower Byte Write	Active	
				H	L	High-Z	D_{IN}	Upper Byte Write	Active	
L	L	D_{IN}	D_{IN}	Word Write	Active					

- Note: 1. X means don't care (must be low or high state).

9. Ordering Information

9.1 Green Package (Pb/Halide-free)

t_{ACC} (ns)	Ordering Code	Flash Boot Block	Flash Plane Architecture	PSRAM	Package	Operation Range
70	AT52BC6402D-70CU	Bottom	64M – Single Bank	1M x 16	66C7	Extended (-30° to 85° C)
	AT52BC6402DT-70CU	Top	64M – Single Bank			

Package Type	
66C7	66-ball, Plastic Chip-size Ball Grid Array Package (CBGA)

10. Packaging Information

10.1 66C7 – CBGA

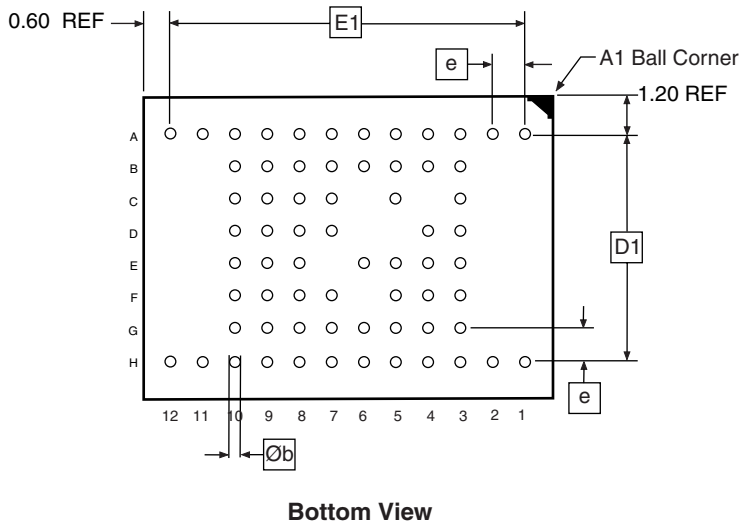
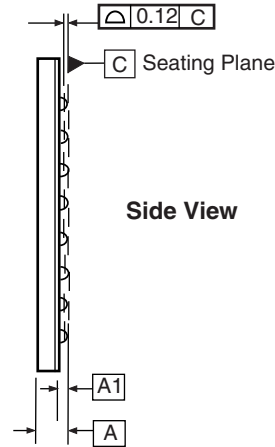
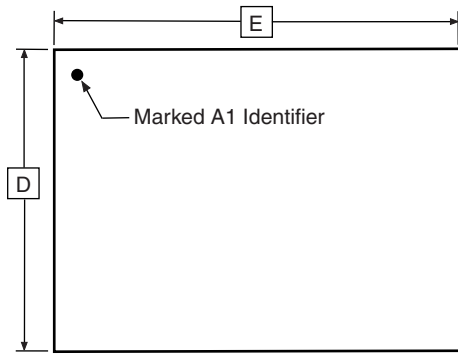

COMMON DIMENSIONS
(Unit of Measure = mm)

SYMBOL	MIN	NOM	MAX	NOTE
E	9.90	10.00	10.10	
E1	8.75	8.80	8.85	
D	7.90	8.00	8.10	
D1	5.55	5.60	5.65	
A	–	–	1.20	
A1	0.25	–	–	
e	0.80 TYP			
Øb	–	0.40	–	

5/01/06



2325 Orchard Parkway
San Jose, CA 95131

TITLE

66C7, 66-ball (12 x 8 Array), 10 x 8 x 1.2 mm Body, 0.8 mm Ball Pitch Chip-scale Ball Grid Array Package (CBGA)

DRAWING NO.

66C7

REV.

A

11. Revision History

Revision No.	History
Revision A – July 2006	<ul style="list-style-type: none"><li data-bbox="766 342 966 367">• Initial Release



Atmel Corporation

2325 Orchard Parkway
San Jose, CA 95131, USA
Tel: 1(408) 441-0311
Fax: 1(408) 487-2600

Regional Headquarters

Europe

Atmel Sarl
Route des Arsenalux 41
Case Postale 80
CH-1705 Fribourg
Switzerland
Tel: (41) 26-426-5555
Fax: (41) 26-426-5500

Asia

Room 1219
Chinachem Golden Plaza
77 Mody Road Tsimshatsui
East Kowloon
Hong Kong
Tel: (852) 2721-9778
Fax: (852) 2722-1369

Japan

9F, Tonetsu Shinkawa Bldg.
1-24-8 Shinkawa
Chuo-ku, Tokyo 104-0033
Japan
Tel: (81) 3-3523-3551
Fax: (81) 3-3523-7581

Atmel Operations

Memory

2325 Orchard Parkway
San Jose, CA 95131, USA
Tel: 1(408) 441-0311
Fax: 1(408) 436-4314

Microcontrollers

2325 Orchard Parkway
San Jose, CA 95131, USA
Tel: 1(408) 441-0311
Fax: 1(408) 436-4314

La Chantrerie
BP 70602
44306 Nantes Cedex 3, France
Tel: (33) 2-40-18-18-18
Fax: (33) 2-40-18-19-60

ASIC/ASSP/Smart Cards

Zone Industrielle
13106 Rousset Cedex, France
Tel: (33) 4-42-53-60-00
Fax: (33) 4-42-53-60-01

1150 East Cheyenne Mtn. Blvd.
Colorado Springs, CO 80906, USA
Tel: 1(719) 576-3300
Fax: 1(719) 540-1759

Scottish Enterprise Technology Park
Maxwell Building
East Kilbride G75 0QR, Scotland
Tel: (44) 1355-803-000
Fax: (44) 1355-242-743

RF/Automotive

Theresienstrasse 2
Postfach 3535
74025 Heilbronn, Germany
Tel: (49) 71-31-67-0
Fax: (49) 71-31-67-2340

1150 East Cheyenne Mtn. Blvd.
Colorado Springs, CO 80906, USA
Tel: 1(719) 576-3300
Fax: 1(719) 540-1759

Biometrics/Imaging/Hi-Rel MPU/ High Speed Converters/RF Datacom

Avenue de Rochepleine
BP 123
38521 Saint-Egreve Cedex, France
Tel: (33) 4-76-58-30-00
Fax: (33) 4-76-58-34-80

Literature Requests

www.atmel.com/literature

Disclaimer: The information in this document is provided in connection with Atmel products. No license, express or implied, by estoppel or otherwise, to any intellectual property right is granted by this document or in connection with the sale of Atmel products. **EXCEPT AS SET FORTH IN ATMEL'S TERMS AND CONDITIONS OF SALE LOCATED ON ATMEL'S WEB SITE, ATMEL ASSUMES NO LIABILITY WHATSOEVER AND DISCLAIMS ANY EXPRESS, IMPLIED OR STATUTORY WARRANTY RELATING TO ITS PRODUCTS INCLUDING, BUT NOT LIMITED TO, THE IMPLIED WARRANTY OF MERCHANTABILITY, FITNESS FOR A PARTICULAR PURPOSE, OR NON-INFRINGEMENT. IN NO EVENT SHALL ATMEL BE LIABLE FOR ANY DIRECT, INDIRECT, CONSEQUENTIAL, PUNITIVE, SPECIAL OR INCIDENTAL DAMAGES (INCLUDING, WITHOUT LIMITATION, DAMAGES FOR LOSS OF PROFITS, BUSINESS INTERRUPTION, OR LOSS OF INFORMATION) ARISING OUT OF THE USE OR INABILITY TO USE THIS DOCUMENT, EVEN IF ATMEL HAS BEEN ADVISED OF THE POSSIBILITY OF SUCH DAMAGES.** Atmel makes no representations or warranties with respect to the accuracy or completeness of the contents of this document and reserves the right to make changes to specifications and product descriptions at any time without notice. Atmel does not make any commitment to update the information contained herein. Unless specifically provided otherwise, Atmel products are not suitable for, and shall not be used in, automotive applications. Atmel's products are not intended, authorized, or warranted for use as components in applications intended to support or sustain life.

© 2006 Atmel Corporation. All rights reserved. Atmel®, logo and combinations thereof, Everywhere You Are® and others are registered trademarks or trademarks of Atmel Corporation or its subsidiaries. Other terms and product names may be trademarks of others.



Printed on recycled paper.

3619A-STKD-7/06