

**4 Watt Extended C-Band VSAT Power Amplifier  
5.9 - 7.1 GHz**

**AM42-0046  
V2**

**Features**

- High Linear Gain: 30 dB Typical
- High Saturated Output Power: +36 dBm Typical
- High Power Added Efficiency: 25% Typical
- 50 Ω Input / Output Broadband Matched
- Integrated Output Power Detector
- Lead-Free Bolt Down Ceramic Package
- RoHS\* Compliant and 260°C Reflow Compatible

**Description**

M/A-COM's AM42-0046 is a three stage MMIC power amplifier in a lead-free, bolt down ceramic package, allowing easy assembly. The AM42-0046 employs a fully matched chip with internally decoupled gate and drain bias networks. The AM42-0046 is designed to operate from a constant current drain supply or a constant voltage gate supply. By varying the bias conditions, the saturated output power performance of this device may be tailored for various applications.

The AM42-0046 is ideally suited for use as an output stage or a driver amplifier in VSAT systems. The AM42-0046 includes internal supply line bypassing in the package, minimizing the number of external components required.

M/A-COM's AM42-0046 is fabricated using a mature 0.5 micron MBE based GaAs MESFET process. The process features full passivation for increased performance and reliability. This product is 100% RF tested to ensure compliance to performance specifications.

**Functional Schematic**

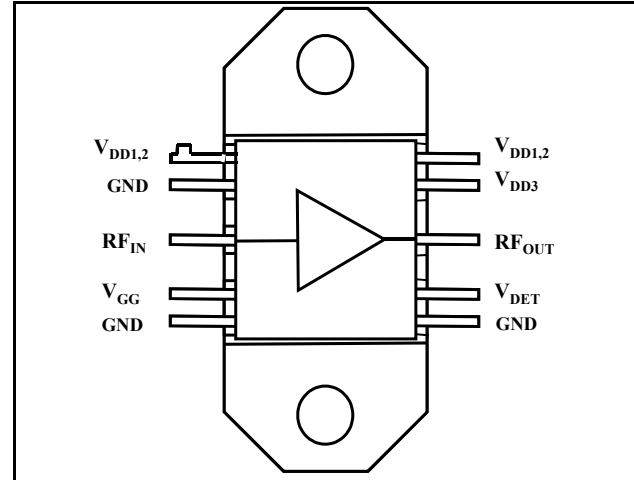

**Pin Configuration**

PIN No.	PIN Name	Description
1	V <sub>DD1,2</sub>	1st and 2nd Stage Drain Supply
2	GND	DC and RF Ground
3	RF <sub>IN</sub>	RF Input
4	V <sub>GG</sub>	Gate Supply
5	GND	DC and RF Ground
6	GND	DC and RF Ground
7	V <sub>DET</sub>	Output Power Detector
8	RF <sub>OUT</sub>	RF Output
9	V <sub>DD3</sub>	3rd Stage Drain Supply
10	V <sub>DD1,2</sub>	1st and 2nd Stage Drain Supply
Flange	GND	DC and RF Ground

**Ordering Information**

Part Number	Package
AM42-0046	Bulk Packaging

\* Restrictions on Hazardous Substances, European Union Directive 2002/95/EC.

**4 Watt Extended C-Band VSAT Power Amplifier  
5.9 - 7.1 GHz**

**AM42-0046  
V2**

**Electrical Specifications:**

**Frequency = 5.9 - 7.1 GHz,  $V_{DD1,2,3} = +8$  Vdc;  $V_{GG} = -5$  Vdc;  $T_A = 25^\circ\text{C}$ ,  $Z_0 = 50 \Omega$**

Parameter	Test Conditions	Units	Min.	Typ.	Max.
Linear Gain	Pin = -4 dBm	dB	27	30	—
Input VSWR	Pin = -4 dBm	Ratio	—	2.5:1	3.0:1
Output VSWR	Pin = -4 dBm	Ratio	—	2.5:1	—
Output Power	Pin = +8 dBm, $I_{ds} = 1900$ mA Typ.	dBm	35	36.0	—
Output Power vs. Frequency	Pin = +8 dBm, $I_{ds} = 1900$ mA Typ. (5.9 to 6.4 GHz)	dB	—	$\pm 0.3$	$\pm 1.25$
	Pin = +8 dBm, $I_{ds} = 1900$ mA Typ. (6.4 to 7.1 GHz)	dB	—	$\pm 0.3$	$\pm 1.25$
Drain Bias Current	Pin = +8 dBm	mA	—	1900	2200
Gate Bias Current	Pin = +8 dBm, $I_{ds} = 1900$ mA Typ.	mA	—	10	25
Detector Voltage	Pin = +8 dBm, $I_{ds} = 1900$ mA Typ.	V	2.0	4.0	—

**Absolute Maximum Ratings** <sup>1,2,3</sup>

Parameter	Absolute Maximum
Input Power	+15 dBm
Operating Voltages	$0 \text{ V} \leq V_{DD} \leq 10 \text{ V}$ $-6 \text{ V} \leq V_{GG} \leq -3 \text{ V}$
$I_{ds}$	2300 mA
Channel Temperature	+150°C
Operating Temperature	-40°C to +80°C
Storage Temperature	-65°C to +150°C

- Exceeding any one or combination of these limits may cause permanent damage to this device.
- M/A-COM does not recommend sustained operation near these survivability limits.
- Adequate heat sinking and grounding required on flange base.

**Handling Procedures**

Please observe the following precautions to avoid damage:

**Static Sensitivity**

Gallium Arsenide Integrated Circuits are sensitive to electrostatic discharge (ESD) and can be damaged by static electricity. Proper ESD control techniques should be used when handling these devices.

**Application Schematic** <sup>4</sup>

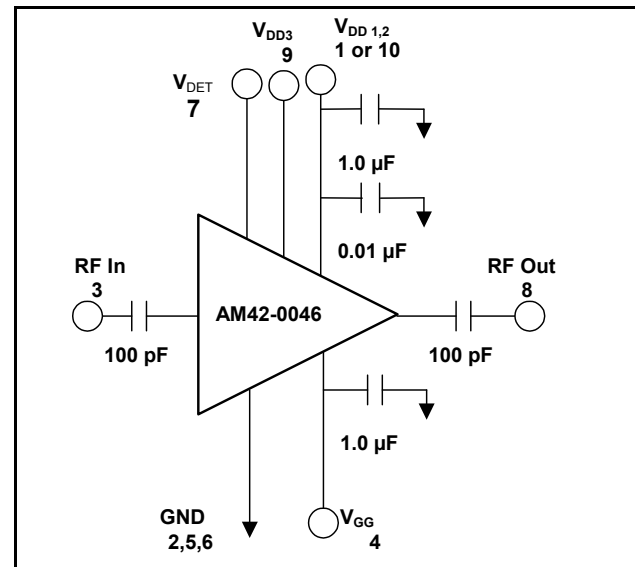

4. External DC blocking capacitors required on the RF ports.

**Operating the AM42-0046**

To operate the AM42-0046, follow these steps.

- Apply -5.0 Volts to  $V_{GG}$ .
- Ramp  $V_{DD}$  to +8 V.
- Apply RF.
- Power down in reverse sequence. Turn gate voltage off last.

**4 Watt Extended C-Band VSAT Power Amplifier  
5.9 - 7.1 GHz**

**AM42-0046  
V2**

**Lead-Free CR-15<sup>†</sup>**

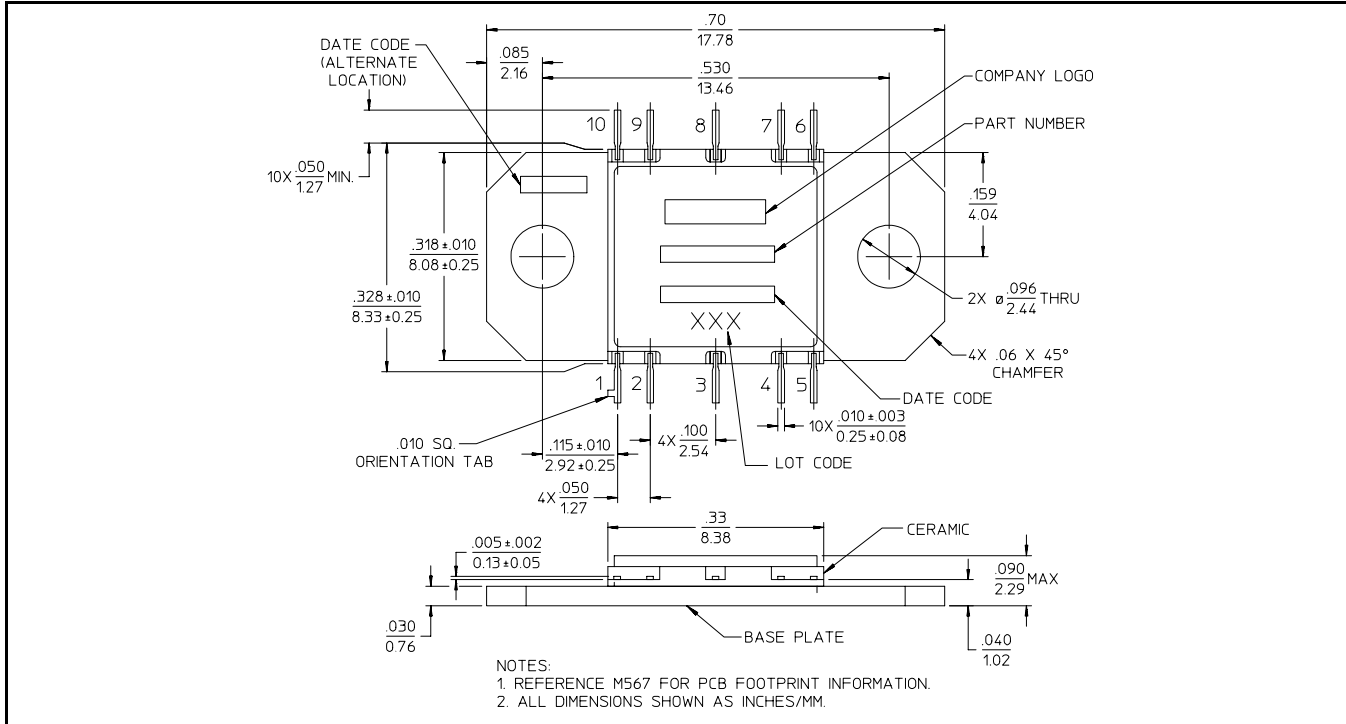

<sup>†</sup> Reference Application Note M538 for lead-free solder reflow recommendations.

**Typical Performance Curves**

**P<sub>OUT</sub> vs. Frequency**

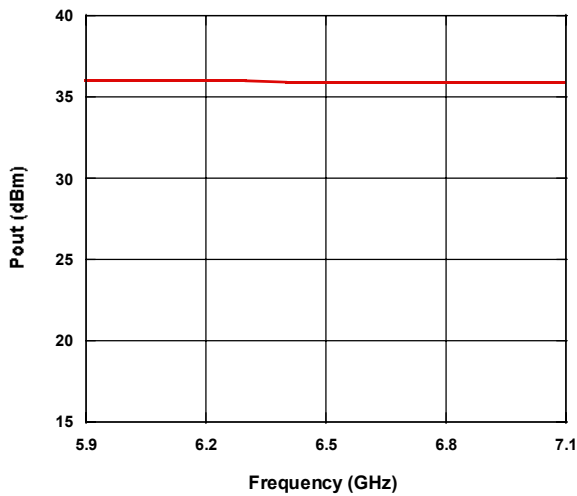

**S<sub>21</sub> vs. Frequency**

