

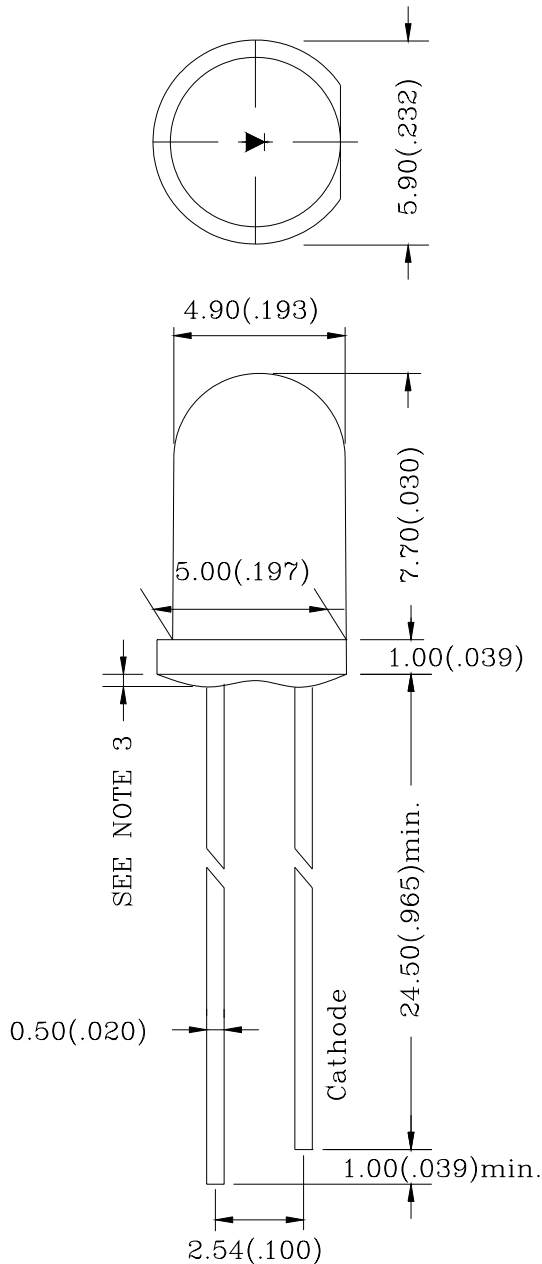

5.0 mm DIA LED LAMP

L-5B47UWC-D1

PACKAGE DIMENSIONS



Note:

1. All Dimensions are in millimeters.
2. Tolerance is $\pm 0.25\text{mm}$ (0.010 ") Unless otherwise specified.
3. Protruded resin under flange is 1.5mm (0.059 ") max.
4. Lead spacing is measured where the leads emerge from the package.
5. Specification are subject to change without notice
6. highlight <-500V the led can withstand the max static level when assembling or operation.



5.0 mm DIA LED LAMP

L-5B47UWC-D1

REV:A / 3

FEATURES

- * SUITABLE HIGH PULSE CURRENT OPERATION
- * EXTRA HIGH RADIANT POWER AND RADIANT INTENSITY
- * HIGH RELIABILITY
- * LOW FORWARD VOLTAGE

CHIP MATERIALS

- * Dice Material : GaInN/GaN
- * Light Color : ULTRA WHITE
- * Lens Color : WATER CLEAR

ABSOLUTE MAXIMUM RATING:(Ta = 25°C)

SYMBOL	DESCRIPTION	ULTRA WHITE	UNIT
PAD	Power Dissipation Per Chip	120	mW
VR	Reverse Voltage Per Chip	5	V
IF	Average Forward Current Per Chip	30	mA
-	Derating Linear From 25°C Per Chip	0.4	mA/°C
Topr	Operating Temperature Range	-25°C to 85°C	
Tstg	Storage Temperature Range	-40°C to 85°C	
Lead Soldering Temperature { 1.6mm(0.063 inch) From Body } 260°C±5°C For 5 Seconds			

ELECTRO-OPTICAL CHARACTERISTICS:(Ta=25°C)

SYMBOL	DESCRIPTION	TEST CONDITION	MIN.	TYP.	MAX.	UNIT
VF	Forward Voltage	IF = 20mA		3.5	4.0	V
IR	Reverse Current	VR = 5V			100	µA
2θ1/2	Half Intensity Angle	IF = 20mA	30	35	40	deg
Iv	Luminous Intensity	IF = 20mA	-	4000	-	mcd
X	Chromaticity	IF = 20mA		0.29		
Y	Coordinates	IF = 20mA		0.30		



5.0 mm DIA LED LAMP

L-5B47UWC-D1

