

Features

- Ideal for DECT Applications
- Power Set Pin for Adjustable Output Power
High Power Mode: 25 dBm
Low Power Mode: 15 dBm
- Power Gain: 25 dB Typical
- Voltage Supply Compensation
- Ramp Power Control: 1.7 V Enable
- Micro-Amp Shutdown Current
- Operates from 1.8 V to 3.6 V
- Lead-Free 3 mm 12-Lead PQFN Package
- 100% Matte Tin Plating over Copper
- Halogen-Free "Green" Mold Compound
- RoHS* Compliant and 260°C Reflow Compatible

Description

The MAAPSS0113 is a three stage power amplifier designed for Digitally Enhanced Cordless Telephone applications. The power amplifier is available in a lead-free 3 mm 12-lead PQFN plastic package.

The MAAPSS0113 features an integrated power enable pin (5) for accurate ramp control and a separate power mode pin (2) for current savings in a low power mode state. Both control pins operate with 1.7 V logic. A voltage compensation circuit is also included for applications where the amplifier supply voltage is not regulated and is directly connected to the battery.

Ordering Information ^{1,2}

Part Number	Package
MAAPSS0113TR-3000	3000 piece reel
MAAPSS0113SMB	Sample Board 1880 - 1930 MHz tuning

1. Reference Application Note M513 for reel size information.
2. All sample boards include 5 loose parts.

Functional Schematic

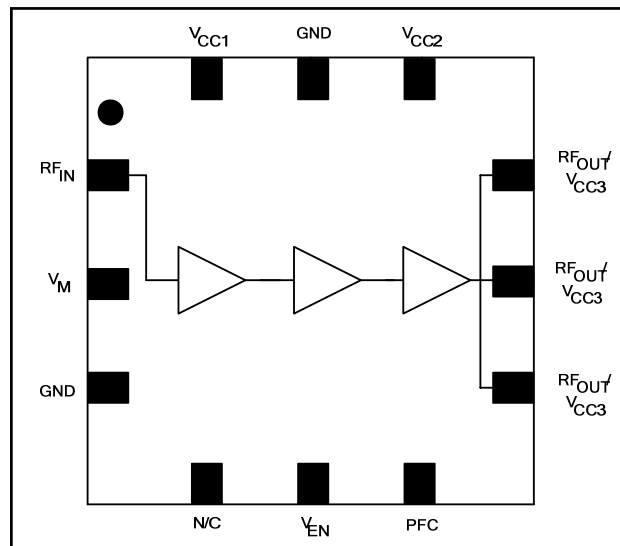

Pin Configuration

Pin No.	Pin Name	Description
1	RF _{IN}	RF Input
2	V _M	Power Mode
3	GND	Ground
4	N/C	No Connection
5	V _{EN}	Power Enable
6	PFC	Power Flatness Control
7	RF _{OUT} / V _{CC3}	RF Output, 3rd Stage Supply
8	RF _{OUT} / V _{CC3}	RF Output, 3rd Stage Supply
9	RF _{OUT} / V _{CC3}	RF Output, 3rd Stage Supply
10	V _{CC2}	2nd Stage Supply
11	GND	Ground
12	V _{CC1}	1st Stage Supply
Pad ³	GND	RF & DC Ground

3. The exposed pad centered on the package bottom must be connected to RF and DC ground.

* Restrictions on Hazardous Substances, European Union Directive 2002/95/EC.

ADVANCED: Data Sheets contain information regarding a product M/A-COM is considering for development. Performance is based on target specifications, simulated results, and/or prototype measurements. Commitment to develop is not guaranteed.

PRELIMINARY: Data Sheets contain information regarding a product M/A-COM has under development. Performance is based on engineering tests. Specifications are typical. Mechanical outline has been fixed. Engineering samples and/or test data may be available. Commitment to produce in volume is not guaranteed.

- **North America** Tel: 800.366.2266 / Fax: 978.366.2266
- **Europe** Tel: 44.1908.574.200 / Fax: 44.1908.574.300
- **Asia/Pacific** Tel: 81.44.844.8296 / Fax: 81.44.844.8298

Visit www.macom.com for additional data sheets and product information.

M/A-COM Inc. and its affiliates reserve the right to make changes to the product(s) or information contained herein without notice.

Electrical Specifications: F = 1880 - 1930 MHz, T_A = 25 °C, Z₀ = 50 Ω

Parameter	Test Conditions	Units	Min.	Typ.	Max.
Input Power		dBm	—	0	—
Input Return Loss	V _M = 0 V	dB	—	11	—
	V _M = 1.7 V	dB	—	12	—
P _{OUT} , High Power Mode (HPM)	V _M = 1.7 V, V _{CC} = 3.0 V	dBm	—	26	27
	V _{CC} = 2.4 V	dBm	—	25.5	—
	V _{CC} = 2.0 V	dBm	22	24	—
	V _{CC} = 1.8 V	dBm	—	23.5	—
P _{OUT} vs. Temperature, HPM	T _A = 0 °C to 50 °C, V _{CC} = 2.4 V	dB	—	0.8	—
P _{OUT} vs. V _{EN}	V _{EN} = 1.6 to 1.9 V, V _{CC} = 2.4 V	dB	—	1	—
Current, HPM	V _M = 1.7 V, V _{CC} = 3.0 V	mA	—	350	500
P _{OUT} , Low Power Mode (LPM)	V _M = 0 V, V _{CC} = 2.4 V	dBm	12	15	—
Current, LPM	V _M = 0 V, V _{CC} = 2.4 V	mA	—	95	150
Current, Shutdown	V _{CC} = 3.0 V, V _{EN} = 0.5 V	μA	—	1	10
Control Pins	V _{EN} , V _M low	V	0	—	0.5
	V _{EN} , V _M high	V	1.6	1.7	1.9
	V _M current	mA	—	0.5	1
	V _{EN} current	mA	—	1	2
Harmonics	V _M = 1.7 V, V _{CC} = 2.4 V	2f ₀	—	-33	—
		3f ₀	—	-35	—
Forward Isolation	V _{EN} = 0 V, V _{CC} = 2.4 V	dB	—	46	—
Stability	+1.5 V < V _{CC} < +3.5 V, P _{OUT} = HPM & LPM, VSWR < 6:1 -20°C < T _A < +70°C	All spurs < -60 dBc			
Turn on/off time	t _{on} : RF burst to (Avg Power – 1 dB)	μS	—	3	—
	t _{off} : (Avg Power – 1 dB) to RF off	μS	—	3	—

Absolute Maximum Ratings ^{4,5,6}

Parameter	Absolute Maximum
Input Power	5 dBm
Operating Supply Voltage	4.0 Volts
Operating Control Voltage	3.0 Volts
Operating Temperature	-20 °C to +85 °C
Channel Temperature	150 °C
Storage Temperature	-40 °C to +150 °C

- Exceeding any one or combination of these limits may cause permanent damage to this device.
- M/A-COM does not recommend sustained operation near these survivability limits.
- For operation above 4V as required for 3 cell systems, a dropping diode is required. See application note page 6.

Logic Table ⁷

V _{EN}	V _M	State
0	0	OFF
0	1	OFF
1	0	LPM
1	1	HPM

7. Logic 1 = 1.6 V to 1.9 V, Logic 0 = 0 V to 0.5 V.

Operating the MAAPSS0113

The MAAPSS0113 is sensitive to electrostatic discharge (ESD). Use proper ESD control techniques when handling this device. To operate the MAAPSS0113, follow these steps. Ramp down or shut down in reverse order.

- Apply V_{CC} (2.4 V).
- Apply V_M (0 or 1.7 V).
- Apply P_{IN} (-2 to 2 dBm).
- Ramp V_{EN} from 0 to 1.7 V.

ADVANCED: Data Sheets contain information regarding a product M/A-COM is considering for development. Performance is based on target specifications, simulated results, and/or prototype measurements. Commitment to develop is not guaranteed.

PRELIMINARY: Data Sheets contain information regarding a product M/A-COM has under development. Performance is based on engineering tests. Specifications are typical. Mechanical outline has been fixed. Engineering samples and/or test data may be available. Commitment to produce in volume is not guaranteed.

• **North America** Tel: 800.366.2266 / Fax: 978.366.2266

• **Europe** Tel: 44.1908.574.200 / Fax: 44.1908.574.300

• **Asia/Pacific** Tel: 81.44.844.8296 / Fax: 81.44.844.8298

Visit www.macom.com for additional data sheets and product information.

M/A-COM Inc. and its affiliates reserve the right to make changes to the product(s) or information contained herein without notice.

Evaluation Board Schematic

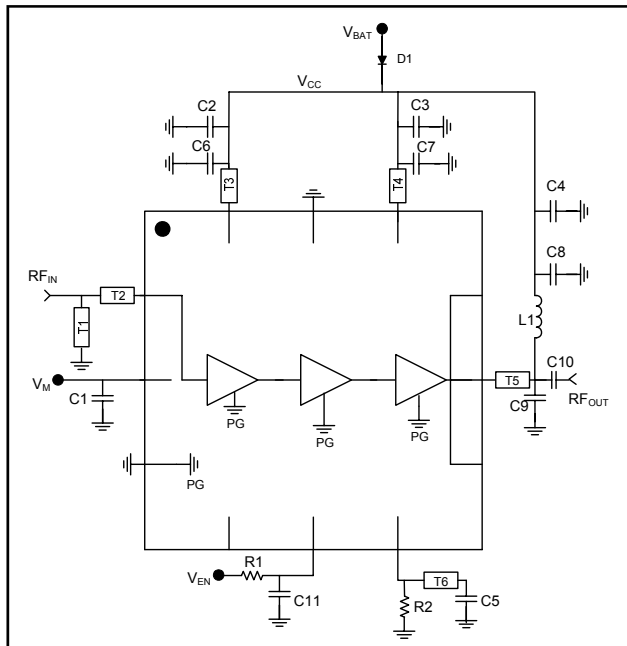

Recommended PCB Configuration

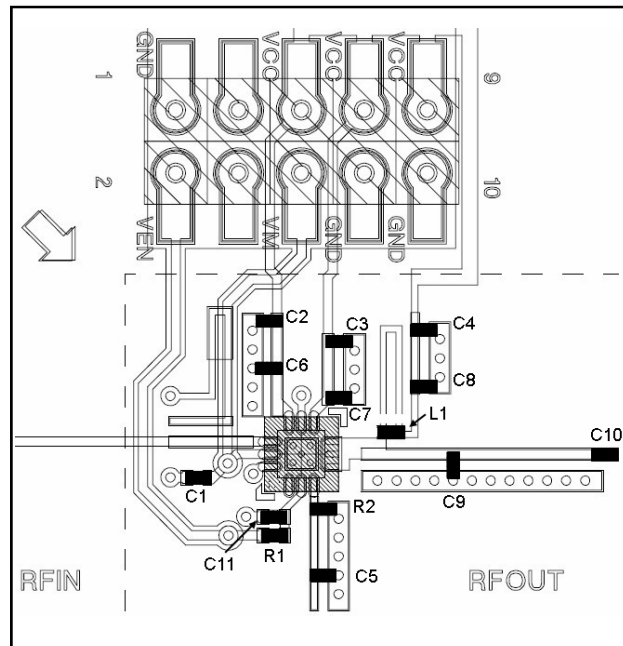

Transmission Line Dimensions, 0.20 mm thick FR4

Designator	Length (mm)	Width (mm)
T1	10.67	.254
T2	2.22	.380
T3	1.80	.380
T4	0.735	.380
T5	4.275	.380
T6	3.13	.254

Parts List

Component	Value	Foot Print	Manufacturer
C1 - C5	1 μ F	0402	Murata
C6	68 pF	0402	Murata
C7	18 pF	0402	Murata
C8	330 pF	0402	Murata
C9	3 pF	0402	Murata
C10	10 pF	0402	Murata
C11	15000 pF	0402	Murata
L1	10 nH	0402	Coilcraft
R1	158 Ω	0402	Panasonic
R2	15 K Ω	0402	Panasonic

ADVANCED: Data Sheets contain information regarding a product M/A-COM is considering for development. Performance is based on target specifications, simulated results, and/or prototype measurements. Commitment to develop is not guaranteed.

PRELIMINARY: Data Sheets contain information regarding a product M/A-COM has under development. Performance is based on engineering tests. Specifications are typical. Mechanical outline has been fixed. Engineering samples and/or test data may be available. Commitment to produce in volume is not guaranteed.

- **North America** Tel: 800.366.2266 / Fax: 978.366.2266
 - **Europe** Tel: 44.1908.574.200 / Fax: 44.1908.574.300
 - **Asia/Pacific** Tel: 81.44.844.8296 / Fax: 81.44.844.8298
- Visit www.macom.com for additional data sheets and product information.

M/A-COM Inc. and its affiliates reserve the right to make changes to the product(s) or information contained herein without notice.

High Power Mode Typical Performance, $V_M = 1.7\text{ V}$ (using the supplied sample board BOM)

P_{OUT} , PAE, I_{CC} vs. P_{IN} @ 2.4 V, 1900 MHz

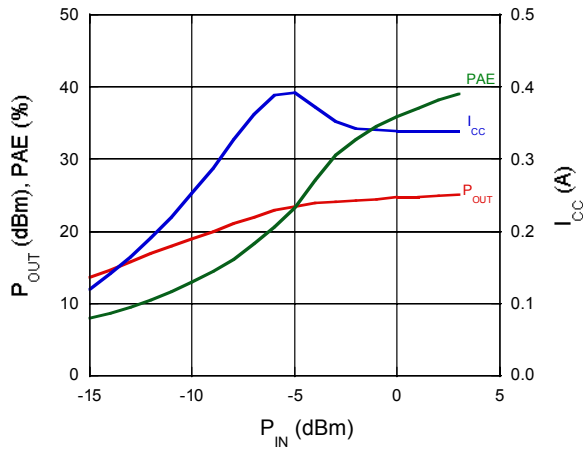

P_{OUT} , PAE, I_{CC} vs. V_{CC} @ 1900 MHz

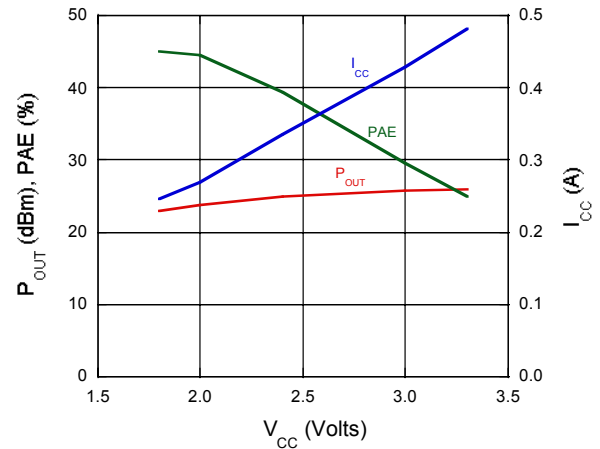

P_{OUT} vs. Temperature @ 1900 MHz, $P_{IN} = 0\text{ dBm}$

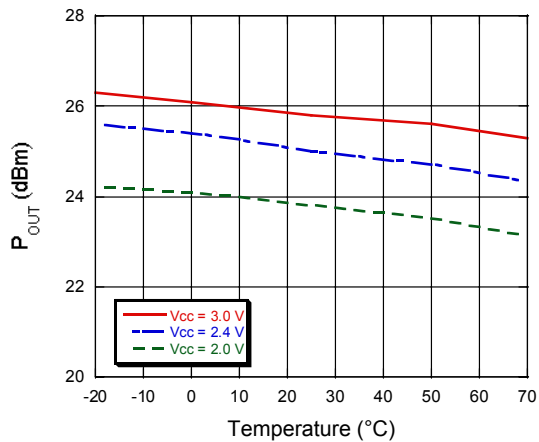

I_{CC} vs. Temperature @ 1900 MHz, $P_{IN} = 0\text{ dBm}$

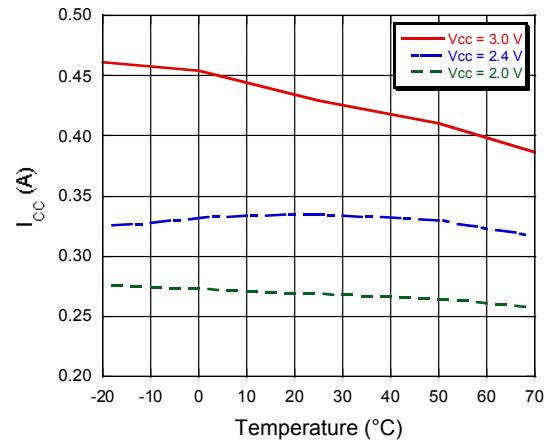

P_{OUT} , $2f_o$, $3f_o$ vs. P_{IN} @ 2.4 V

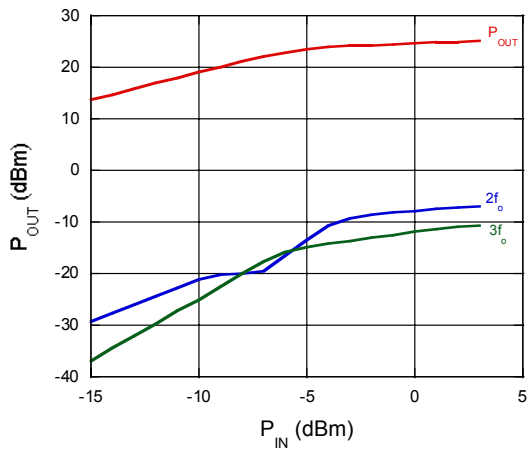

P_{OUT} , PAE, I_{CC} vs. Frequency @ $V_{CC} = 2.4\text{ V}$, $P_{IN} = 0\text{ dBm}$

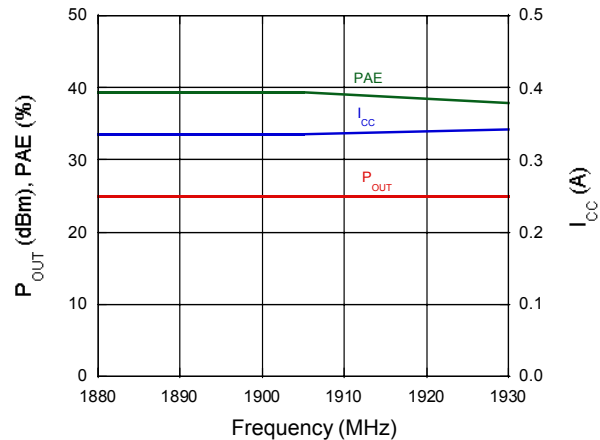

4

ADVANCED: Data Sheets contain information regarding a product M/A-COM is considering for development. Performance is based on target specifications, simulated results, and/or prototype measurements. Commitment to develop is not guaranteed.

PRELIMINARY: Data Sheets contain information regarding a product M/A-COM has under development. Performance is based on engineering tests. Specifications are typical. Mechanical outline has been fixed. Engineering samples and/or test data may be available. Commitment to produce in volume is not guaranteed.

- **North America** Tel: 800.366.2266 / Fax: 978.366.2266
 - **Europe** Tel: 44.1908.574.200 / Fax: 44.1908.574.300
 - **Asia/Pacific** Tel: 81.44.844.8296 / Fax: 81.44.844.8298
- Visit www.macom.com for additional data sheets and product information.

M/A-COM Inc. and its affiliates reserve the right to make changes to the product(s) or information contained herein without notice.

Low Power Mode Typical Performance, $V_M = 0$ V (using the supplied sample board BOM)

P_{OUT} , I_{CC} vs. P_{IN} @ 2.4 V, 1900 MHz

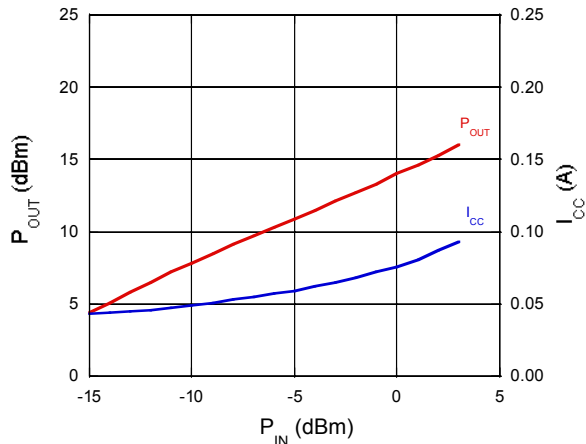

P_{OUT} , I_{CC} vs. V_{CC} @ 1900 MHz

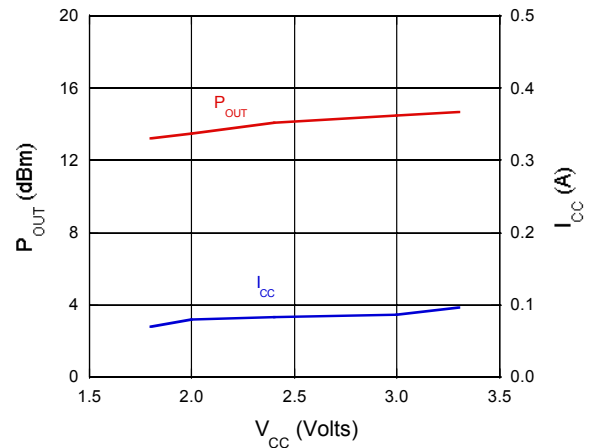

P_{OUT} vs. Temperature @ 1900 MHz, $P_{IN} = 0$ dBm

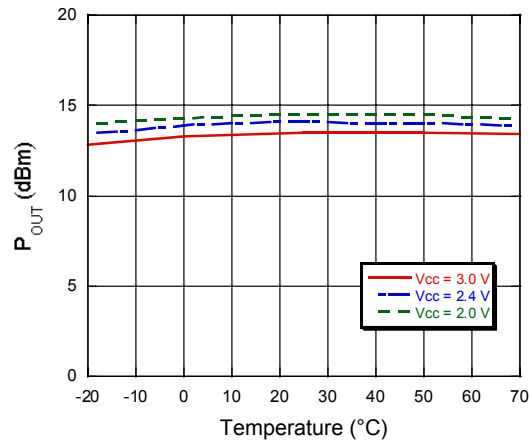

I_{CC} vs. Temperature @ 1900 MHz, $P_{IN} = 0$ dBm

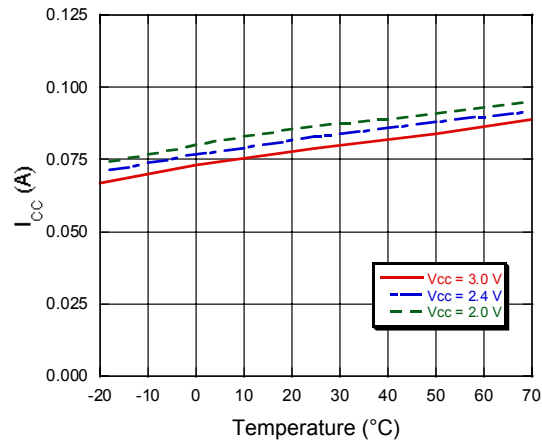

P_{out} vs. V_{EN} @ $V_{CC} = 2.4$ V, $V_M = 1.7$ V, $P_{IN} = 0$ dBm

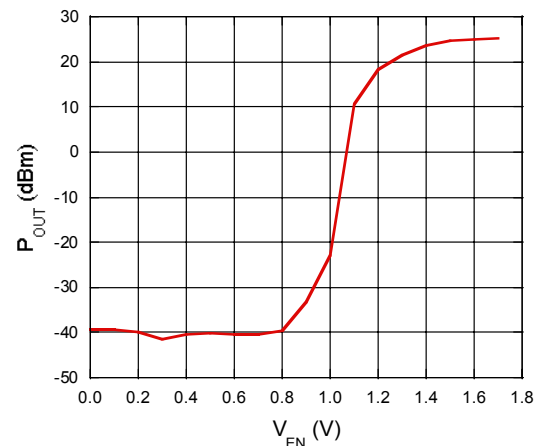

S_{11} vs. Frequency, State @ $V_{CC} = 2.4$ V

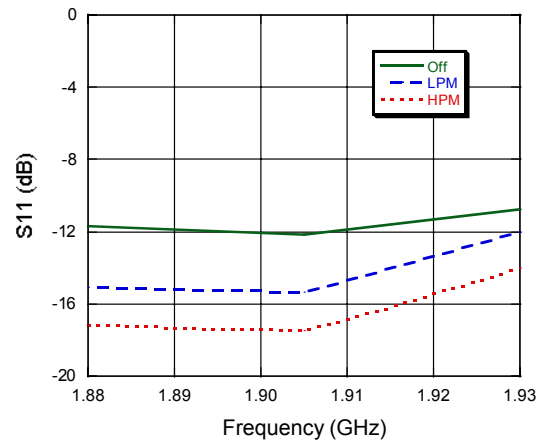

ADVANCED: Data Sheets contain information regarding a product M/A-COM is considering for development. Performance is based on target specifications, simulated results, and/or prototype measurements. Commitment to develop is not guaranteed.

PRELIMINARY: Data Sheets contain information regarding a product M/A-COM has under development. Performance is based on engineering tests. Specifications are typical. Mechanical outline has been fixed. Engineering samples and/or test data may be available. Commitment to produce in volume is not guaranteed.

- **North America** Tel: 800.366.2266 / Fax: 978.366.2266
 - **Europe** Tel: 44.1908.574.200 / Fax: 44.1908.574.300
 - **Asia/Pacific** Tel: 81.44.844.8296 / Fax: 81.44.844.8298
- Visit www.macom.com for additional data sheets and product information.

M/A-COM Inc. and its affiliates reserve the right to make changes to the product(s) or information contained herein without notice.

High Voltage Operation (3 Cells)

The MAAPSS0113 amplifier product is designed for use in phone systems using 2 battery cells for mobile units (3.6V charging, 2.4V nom.) or up to 3.6V regulated for base-station units. For operation with higher supply voltages such as in 3 cell mobile units (4.5V charging), a dropping diode is required to reduce the voltage to the amplifier. An example schematic is shown in Figure 1. A series diode is placed between the battery supply and the three stages of the amplifier. An example diode is the Vishay ES1A surface mount diode. This diode has a maximum forward current of 1A and a forward voltage drop of 1V.

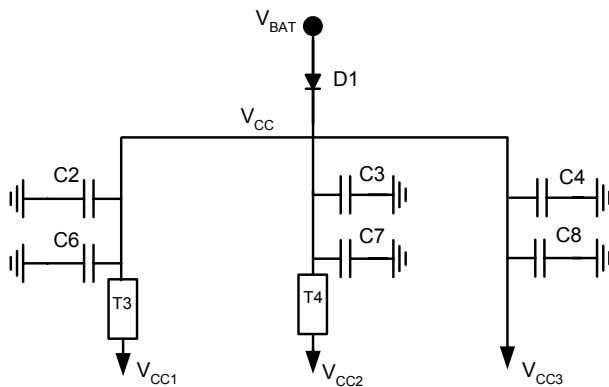

Figure 1.
Supply schematic for 3 cell operation showing external dropping diode, ex. Vishay ES1A

Figure 2 shows the measured affect of the dropping diode on the supply voltage (V_{CC}) to the amplifier. Because of the approximate 1V forward drop of the diode, the maximum supply to the amplifier is 3.6V for a charging condition of 4.5V. Figures 3 and 4 show the power and current versus a 3 cell battery range, respectively. The 3 cell performance with the dropping diode is very similar to the electrical specification at 2.4V shown on page 2. The key to matching this data is choosing a diode with approximately 1V forward drop. Because of this forward drop, the maximum voltage from the battery supply can increase from 4V to 5V.

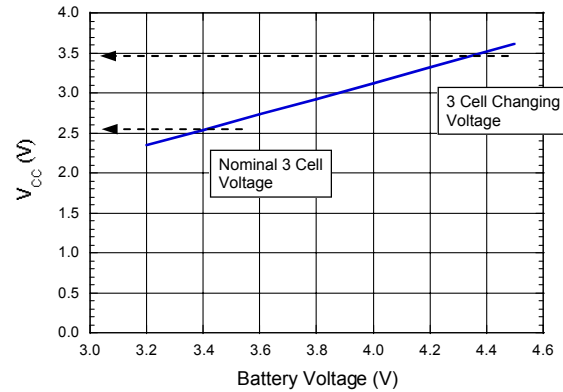

Figure 2.
 V_{CC} vs. 3 cell battery voltage with series dropping diode.

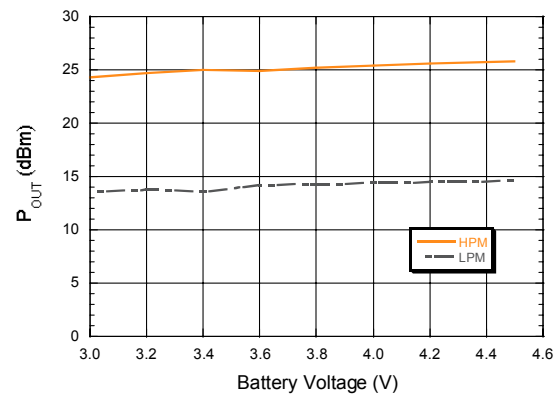

Figure 3.
 P_{out} vs. 3 cell battery voltage

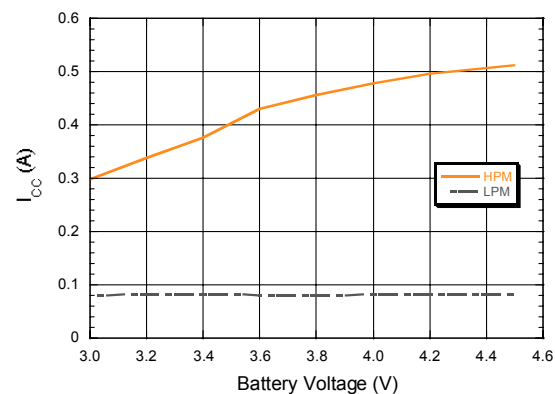
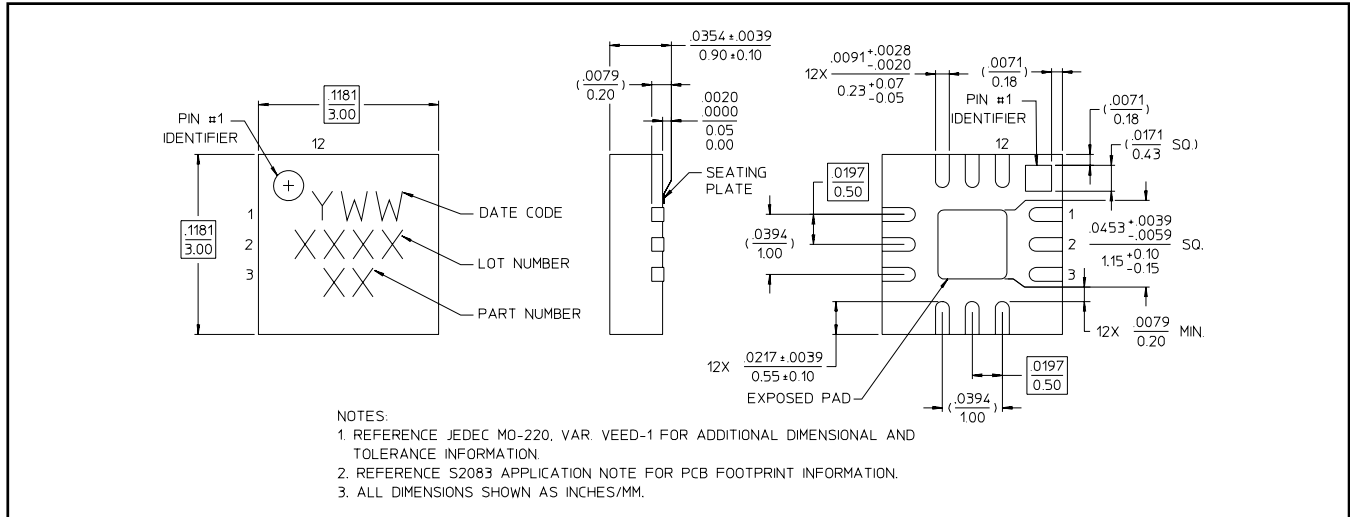

Figure 4.
Current vs. 3 cell battery voltage

Lead-Free 3 mm 12-lead PQFN†



† Reference Application Note M538 for lead-free solder reflow recommendations.
Meets JEDEC moisture sensitivity level 1 requirements.

Handling Procedures

Please observe the following precautions to avoid damage:

Static Sensitivity

Gallium Arsenide Integrated Circuits are sensitive to electrostatic discharge (ESD) and can be damaged by static electricity. Proper ESD control techniques should be used when handling these devices.