

# UAA3587 RF SiP

## Complete, single-package GSM/GPRS/EDGE RF transceiver

Integrating passive and active components into a single package, this complete RF transceiver improves performance while eliminating 35 external components and enabling an RF front-end of less than 2.5 cm<sup>2</sup>.

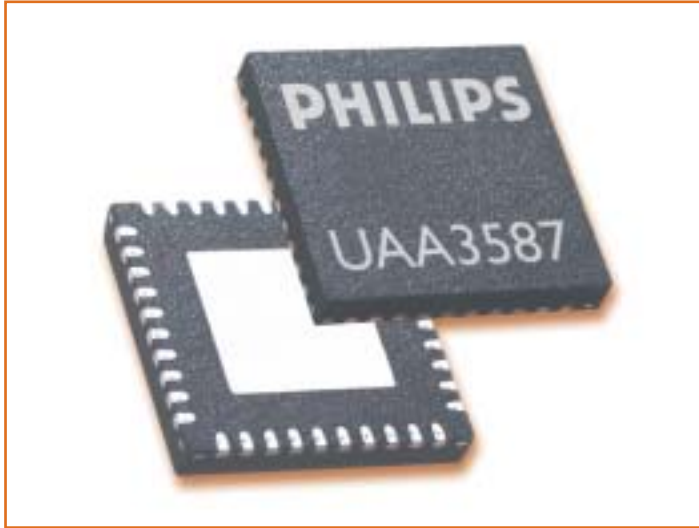

### Key features

- Advanced, single-package RF transceiver for GSM/GPRS/EDGE
  - 30% smaller than previous best-in-class solutions
  - Total RF front-end < 2.5 cm<sup>2</sup>
- Eliminates 35 external components
  - Integrated Tx baluns, loop filters, decoupling capacitors
  - Integrated Fractional-N RF synthesizer with AFC control
  - Semi-integrated 26-MHz oscillator with integrated supply regulator
- Superior performance from optimal process technologies
  - 0.25µm QUBiC4 BiCMOS for RF performance
  - Passive integration for lower component count
  - Flip-chip assembly shortens interconnects, reduces parasitics
- Efficient, flexible architectures
  - NZIF receiver architecture
  - Direct conversion upmixer transmit architecture
  - Triple-output control of RF antenna switches
  - Any combination of 3 out of 4 bands (850 / 900 / 1800 / 1900 MHz)
- HVQFN40 package (6 x 6 x 0.85 mm)

Semiconductors

The UAA3587, the first Philips System-in-Package (SiP) solution to use a new silicon-based structure, is a complete RF transceiver for GSM, GPRS, and EDGE mobile phones. It uses innovative techniques to combine passive and active components in a single package, maximizing RF performance while significantly reducing external component count and overall design size.

The SiP uses 35 fewer external RF components than the previous generation and enables a design area of less than 2.5 cm<sup>2</sup> for the complete radio sub-system. Combined with the miniaturization of other components, the SiP offers increased RF performance while saving 30% more space than the previous “best-in-class” solution and 50% more than the industry average.

By replacing dozens of active and passive components in a single, drop-in solution, the SiP dramatically cuts assembly costs and time-to-market. By bringing the passive component networks closer together, the SiP shortens interconnect lengths and reduces parasitics, thereby improving overall RF performance.

### Designed for efficiency, flexibility

The receiver uses a Near Zero-IF (NZIF) architecture. The transmitter uses a direct-conversion upmixer architecture that delivers -163 dBm/Hz at 20 MHz, a carrier rejection of greater than 35 dB, and a transmit attenuation range of 40 dB. The RF antenna switches can be controlled by up to three outputs and the transceiver as a whole can support any combination of 3 out of 4 GSM/GPRS/EDGE bands (850 / 900 / 1800 / 1900 MHz).

The SiP includes integrated Tx baluns, loop filters, and decoupling capacitors. There is an integrated Fractional-N RF synthesizer with AFC control, as well as a semi-integrated, 26-MHz oscillator clock with integrated supply regulator.

# PHILIPS

# UAA3587 RF SiP

## Complete, single-package GSM/GPRS/EDGE RF transceiver



### Innovative silicon-based structure

Each portion of the SiP is fabricated in the process technology ideally suited to its function, so each individual die delivers the ultimate balance of performance, size, and cost.

To combine high-performance passive components with active transistors, the UAA3587 uses the QUBiC4 BiCMOS process (0.25µm, 40/90 GHz  $F_T/F_{MAX}$ ). Less critical passive components, or components that require significant silicon area, are fabricated in Philips-proprietary Passive Integration Technologies, which only involve back-end (and hence lower-cost) silicon wafer processing.

Using flip-chip techniques, the active die is direct-bonded to the passive component die, thereby eliminating the need for any mechanical or interconnect substrate. The whole assembly is then housed in a standard 40-pin HVQFN package that measures only 36 mm<sup>2</sup>.

### Part of the Nexperia Cellular System Solution

The UAA3587 is in mass production and has already been designed into Nexperia Cellular System Solutions, the Philips family of hardware and software reference designs for multimedia mobile phones. The SiP provides complete RF transceiver functionality in the 61x0 System Solution, a design optimized for the feature phone market.

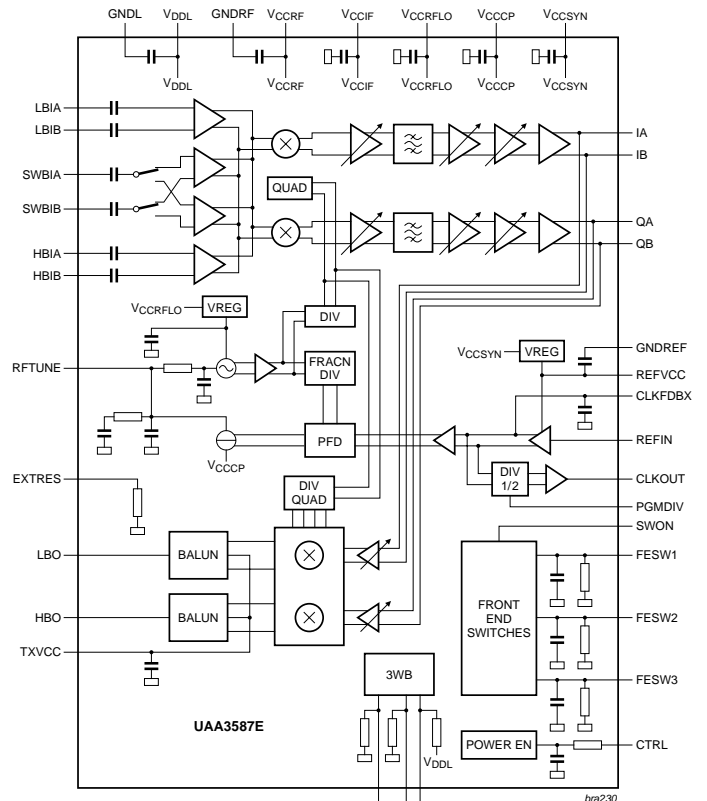

UAA3587 RF SiP block diagram

### Philips Semiconductors

Philips Semiconductors is a worldwide company with over 100 sales offices in more than 50 countries. For a complete up-to-date list of our sales offices please e-mail [sales.addresses@www.semiconductors.philips.com](mailto:sales.addresses@www.semiconductors.philips.com)

A complete list will be sent to you automatically.

You can also visit our website <http://www.semiconductors.philips.com/sales>

© Koninklijke Philips Electronics N.V. 2004

SCS 78

All rights reserved. Reproduction in whole or in part is prohibited without the prior written consent of the copyright owner. The information presented in this document does not form part of any quotation or contract, is believed to be accurate and reliable and may be changed without notice. No liability will be accepted by the publisher for any consequence of its use. Publication thereof does not convey nor imply any license under patent- or other industrial or intellectual property rights.



date of release: September 2004  
document order number: 9397 750 14047

Published in the Netherlands