

DATA SHEET

UAA3592

Wideband code division multiple
access frequency division duplex
power amplifier

Objective specification

2002 Jul 02

Wideband code division multiple access frequency division duplex power amplifier

UAA3592

FEATURES

- 3.6 V nominal supply voltage
- 24 dBm average output power
- 0 dBm input power
- Wide operating temperature range from -30 to $+70$ °C
- HVQFN16 package.

GENERAL DESCRIPTION

The UAA3592 is a Wideband Code Division Multiple Access (WCDMA) silicon bipolar transistor Monolithic Microwave Integrated Circuit (MMIC) Power Amplifier (PA). The circuit is specially designed to operate at a nominal 3.6 V battery supply voltage. It includes a current saving architecture at low output power levels.

APPLICATIONS

- WCDMA-FDD applications.

QUICK REFERENCE DATA

$T_{amb} = 25$ °C; $V_{C1} = 3.6$ V; $V_{reg} = 2.7$ V.

SYMBOL	PARAMETER	MIN.	TYP.	MAX.	UNIT
V_{C1}	positive supply voltage	–	3.6	–	V
$P_{o(max)}$	maximum output power	–	24.5	–	dBm
η	efficiency at maximum power	–	35	–	%
T_{amb}	ambient temperature	-30	–	$+70$	°C

ORDERING INFORMATION

TYPE NUMBER	PACKAGE		
	NAME	DESCRIPTION	VERSION
UAA3592HN	HVQFN16	plastic, heatsink very thin quad flat package; no leads; 16 terminals; body $4 \times 4 \times 0.85$ mm	SOT629-1

Wideband code division multiple access
frequency division duplex power amplifier

UAA3592

BLOCK DIAGRAM

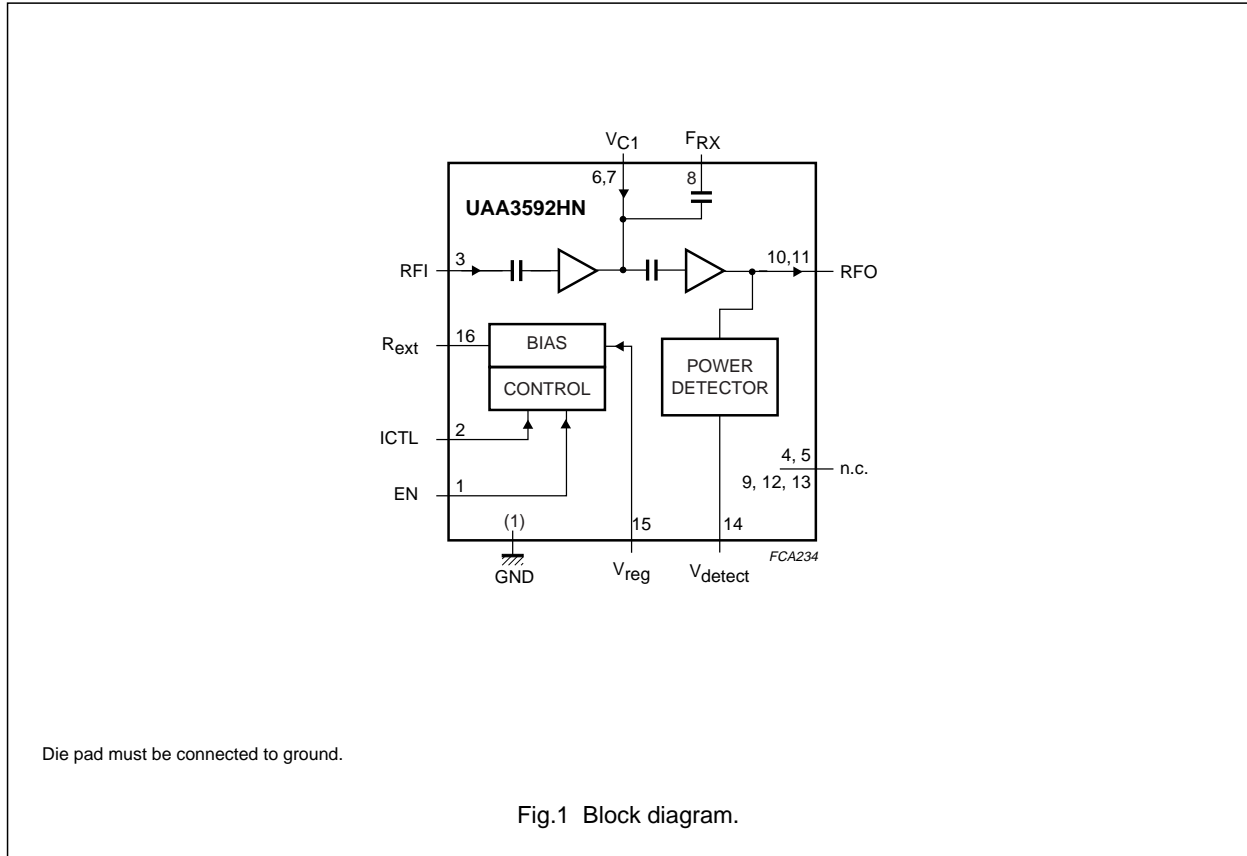

Wideband code division multiple access frequency division duplex power amplifier

UAA3592

PINNING

SYMBOL	PIN	DESCRIPTION
EN	1	enable input
ICTL	2	current control input
RFI	3	power amplifier input
n.c.	4	not connected
n.c.	5	not connected
V_{C1}	6	supply voltage for the first stage collector
V_{C1}	7	supply voltage for the first stage collector
F_{RX}	8	RX filter
n.c.	9	not connected
RFO	10	power amplifier output
RFO	11	power amplifier output
n.c.	12	not connected
n.c.	13	not connected
V_{detect}	14	power detection
V_{reg}	15	regulated supply voltage
R_{ext}	16	connection to external resistor
	die pad	ground

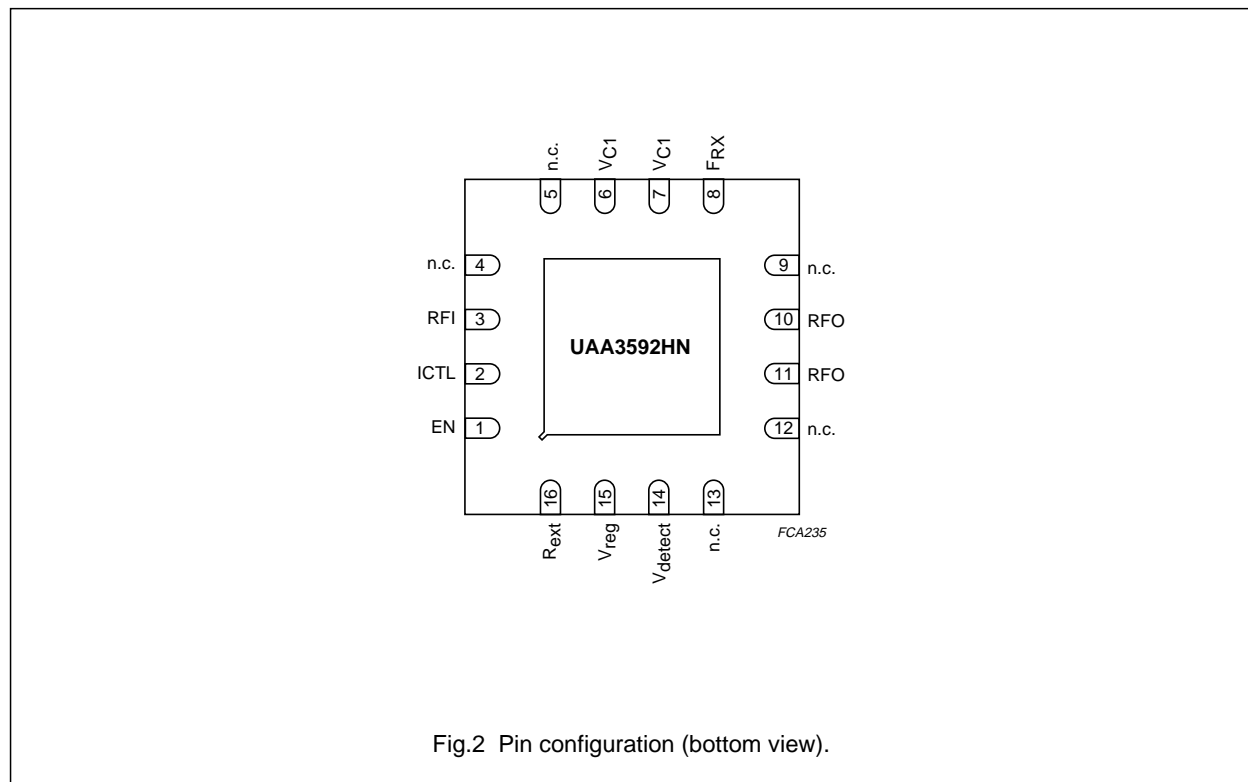

Fig.2 Pin configuration (bottom view).

Wideband code division multiple access frequency division duplex power amplifier

UAA3592

FUNCTIONAL DESCRIPTION

Operating conditions

The UAA3592 is designed to meet the "Third Generation Partnership Project (3GPP) specification" for the Universal Mobile Telecommunication System (UMTS) standard.

Power amplifier

The device is intended for WCDMA power amplification. The control signals select the bias current as given in Table 1.

Table 1 Current control

EN	ICTL	DESCRIPTION
0	0	off
0	1	off
1	0	nominal bias current
1	1	bias current is reduced by 50% on the second stage

LIMITING VALUES

In accordance with the Absolute Maximum Rating System (IEC 60134).

SYMBOL	PARAMETER	CONDITIONS	MIN.	MAX.	UNIT
V_{C1}	supply voltage for the first stage collector		–	5.5	V
V_{reg}	regulated voltage		–	3.3	V
$T_{j(max)}$	maximum operating junction temperature		–	150	°C
P_{tot}	total power dissipation	note 1	–	tbf	mW
P_i	input power		–	10	dBm
T_{stg}	storage temperature		–55	+150	°C

Note

1. On Philips evaluation board.

HANDLING

Do not operate or store near strong electrostatic fields.

Mets class 1 ESD test requirements (Human Body Model - HBM), in accordance with "EIA/JESD22-A114-A (October 1997)" and class A ESD test requirements (Machine Model - MM), in accordance with "EIA/JESD22-A115.-A (October 1997)".

THERMAL CHARACTERISTICS

SYMBOL	PARAMETER	CONDITIONS	VALUE	UNIT
$R_{th(j-a)}$	thermal resistance from junction to ambient	in free air; note 1	tbf	K/W

Note

1. On Philips evaluation board.

Wideband code division multiple access frequency division duplex power amplifier

UAA3592

DC CHARACTERISTICS

$V_{C1} = 3.6\text{ V}$; $V_{\text{reg}} = 2.7\text{ V}$; $T_{\text{amb}} = 25\text{ °C}$; unless otherwise specified.

SYMBOL	PARAMETER	CONDITIONS	MIN.	TYP.	MAX.	UNIT
V_{C1}	supply voltage for the first stage collector		3.25	3.6	4.5	V
V_{reg}	regulated supply voltage		2.6	2.7	3	V
$I_{C1(\text{q})}$	quiescent supply current	pin ICTL is LOW	–	–	50	mA
		pin ICTL is HIGH	–	–	25	mA
I_{leak}	leakage current	$V_{C1} = 4.5\text{ V}$; pin EN is LOW	–	–	5	μA
Inputs EN and ICTL						
V_{IL}	LOW-level input voltage		–	–	1.1	V
V_{IH}	HIGH-level input voltage		1.5	–	–	V

AC CHARACTERISTICS

$V_{C1} = 3.6\text{ V}$; $V_{\text{reg}} = 2.7\text{ V}$; $T_{\text{amb}} = 25\text{ °C}$; $f_{\text{RF}} = 1920\text{ to }1980\text{ MHz}$; P_{i} adjusted for $P_{\text{o}} = 24.5\text{ dBm}$; $R_{\text{ext}} = 2.2\text{ k}\Omega$; measured and guaranteed on Philips evaluation board; unless otherwise specified.

SYMBOL	PARAMETER	CONDITIONS	MIN.	TYP.	MAX.	UNIT
P_{i}	input power	$T_{\text{amb}} = -30\text{ to }+70\text{ °C}$	–6	–	0	dBm
$P_{\text{o}(\text{max})}$	maximum output power	$T_{\text{amb}} = -30\text{ to }+70\text{ °C}$; $V_{C1} = 3.25\text{ V}$	22.5	–	–	dBm
η	efficiency		30	–	–	%
$N_{\text{o}(\text{RX})}$	output noise in RX band	at 190 MHz offset; $f_{\text{RF}} = 2110\text{ to }2170\text{ MHz}$	–	–	–135	dBm/Hz
H2	second-harmonic level		–	–	–40	dBc
H3	third-harmonic level		–	–	–45	dBc
$\text{CPR}_{(\text{adj})}$	adjacent channel power ratio	$B = 3.84\text{ MHz}$; at 5 MHz from carrier frequency	–	–	–37	dBc
$\text{CPR}_{(\text{alt})}$	first alternate channel power ratio	$B = 3.84\text{ MHz}$; at 10 MHz from carrier frequency	–	–	–47	dBc
RL_{i}	input return loss	$T_{\text{amb}} = -30\text{ to }+70\text{ °C}$; $f_{\text{RF}} = 1.5\text{ to }2.5\text{ GHz}$	–	–	–6	dB
$G_{(\text{ripple})}$	ripple gain	$\Delta f_{\text{RF}} = 5\text{ MHz}$; $f_{\text{RF}} = 1920\text{ to }1980\text{ MHz}$	–	–	0.5	dB
ΔG	gain variation	P_{o} up to 24.5 dBm; pin ICTL is LOW	–	–	tbF	dB

Wideband code division multiple access
frequency division duplex power amplifier

UAA3592

PACKAGE OUTLINE

HVQFN16: plastic thermal enhanced very thin quad flat package; no leads;
16 terminals; body 4 x 4 x 0.85 mm

SOT629-1

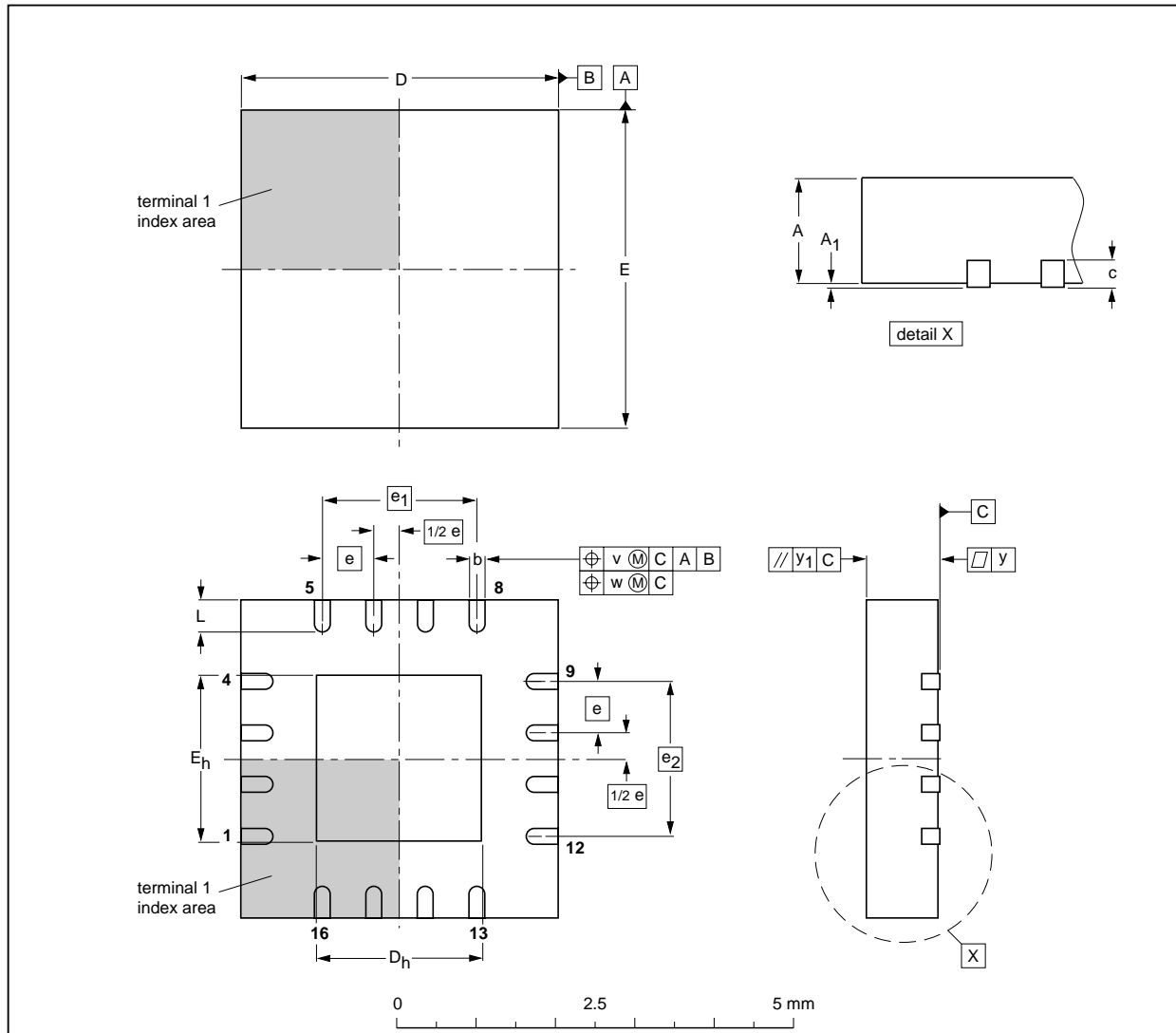

DIMENSIONS (mm are the original dimensions)

UNIT	A ⁽¹⁾ max.	A ₁	b	c	D ⁽¹⁾	D _h	E ⁽¹⁾	E _h	e	e ₁	e ₂	L	v	w	y	y ₁
mm	1	0.05 0.00	0.40 0.23	0.2	4.05 3.95	2.25 1.95	4.05 3.95	2.25 1.95	0.65	1.95	1.95	0.75 0.35	0.1	0.05	0.05	0.1

Note

1. Plastic or metal protrusions of 0.075 mm maximum per side are not included.

OUTLINE VERSION	REFERENCES				EUROPEAN PROJECTION	ISSUE DATE
	IEC	JEDEC	JEITA			
SOT629-1	---	MO-220	---			01-06-28 01-08-08

Wideband code division multiple access frequency division duplex power amplifier

UAA3592

SOLDERING

Introduction to soldering surface mount packages

This text gives a very brief insight to a complex technology. A more in-depth account of soldering ICs can be found in our *"Data Handbook IC26; Integrated Circuit Packages"* (document order number 9398 652 90011).

There is no soldering method that is ideal for all surface mount IC packages. Wave soldering can still be used for certain surface mount ICs, but it is not suitable for fine pitch SMDs. In these situations reflow soldering is recommended.

Reflow soldering

Reflow soldering requires solder paste (a suspension of fine solder particles, flux and binding agent) to be applied to the printed-circuit board by screen printing, stencilling or pressure-syringe dispensing before package placement.

Several methods exist for reflowing; for example, convection or convection/infrared heating in a conveyor type oven. Throughput times (preheating, soldering and cooling) vary between 100 and 200 seconds depending on heating method.

Typical reflow peak temperatures range from 215 to 250 °C. The top-surface temperature of the packages should preferably be kept below 220 °C for thick/large packages, and below 235 °C for small/thin packages.

Wave soldering

Conventional single wave soldering is not recommended for surface mount devices (SMDs) or printed-circuit boards with a high component density, as solder bridging and non-wetting can present major problems.

To overcome these problems the double-wave soldering method was specifically developed.

If wave soldering is used the following conditions must be observed for optimal results:

- Use a double-wave soldering method comprising a turbulent wave with high upward pressure followed by a smooth laminar wave.
- For packages with leads on two sides and a pitch (e):
 - larger than or equal to 1.27 mm, the footprint longitudinal axis is **preferred** to be parallel to the transport direction of the printed-circuit board;
 - smaller than 1.27 mm, the footprint longitudinal axis **must** be parallel to the transport direction of the printed-circuit board.

The footprint must incorporate solder thieves at the downstream end.

- For packages with leads on four sides, the footprint must be placed at a 45° angle to the transport direction of the printed-circuit board. The footprint must incorporate solder thieves downstream and at the side corners.

During placement and before soldering, the package must be fixed with a droplet of adhesive. The adhesive can be applied by screen printing, pin transfer or syringe dispensing. The package can be soldered after the adhesive is cured.

Typical dwell time is 4 seconds at 250 °C.

A mildly-activated flux will eliminate the need for removal of corrosive residues in most applications.

Manual soldering

Fix the component by first soldering two diagonally-opposite end leads. Use a low voltage (24 V or less) soldering iron applied to the flat part of the lead. Contact time must be limited to 10 seconds at up to 300 °C.

When using a dedicated tool, all other leads can be soldered in one operation within 2 to 5 seconds between 270 and 320 °C.

Wideband code division multiple access frequency division duplex power amplifier

UAA3592

Suitability of surface mount IC packages for wave and reflow soldering methods

PACKAGE	SOLDERING METHOD	
	WAVE	REFLOW ⁽¹⁾
BGA, HBGA, LFBGA, SQFP, TFBGA	not suitable	suitable
HBCC, HLQFP, HSQFP, HSOP, HTQFP, HTSSOP, HVQFN, SMS	not suitable ⁽²⁾	suitable
PLCC ⁽³⁾ , SO, SOJ	suitable	suitable
LQFP, QFP, TQFP	not recommended ⁽³⁾⁽⁴⁾	suitable
SSOP, TSSOP, VSO	not recommended ⁽⁵⁾	suitable

Notes

1. All surface mount (SMD) packages are moisture sensitive. Depending upon the moisture content, the maximum temperature (with respect to time) and body size of the package, there is a risk that internal or external package cracks may occur due to vaporization of the moisture in them (the so called popcorn effect). For details, refer to the Drypack information in the *"Data Handbook IC26; Integrated Circuit Packages; Section: Packing Methods"*.
2. These packages are not suitable for wave soldering. On versions with the heatsink on the bottom side, the solder cannot penetrate between the printed-circuit board and the heatsink. On versions with the heatsink on the top side, the solder might be deposited on the heatsink surface.
3. If wave soldering is considered, then the package must be placed at a 45° angle to the solder wave direction. The package footprint must incorporate solder thieves downstream and at the side corners.
4. Wave soldering is only suitable for LQFP, TQFP and QFP packages with a pitch (e) equal to or larger than 0.8 mm; it is definitely not suitable for packages with a pitch (e) equal to or smaller than 0.65 mm.
5. Wave soldering is only suitable for SSOP and TSSOP packages with a pitch (e) equal to or larger than 0.65 mm; it is definitely not suitable for packages with a pitch (e) equal to or smaller than 0.5 mm.

Wideband code division multiple access frequency division duplex power amplifier

UAA3592

DATA SHEET STATUS

DATA SHEET STATUS ⁽¹⁾	PRODUCT STATUS ⁽²⁾	DEFINITIONS
Objective data	Development	This data sheet contains data from the objective specification for product development. Philips Semiconductors reserves the right to change the specification in any manner without notice.
Preliminary data	Qualification	This data sheet contains data from the preliminary specification. Supplementary data will be published at a later date. Philips Semiconductors reserves the right to change the specification without notice, in order to improve the design and supply the best possible product.
Product data	Production	This data sheet contains data from the product specification. Philips Semiconductors reserves the right to make changes at any time in order to improve the design, manufacturing and supply. Changes will be communicated according to the Customer Product/Process Change Notification (CPCN) procedure SNW-SQ-650A.

Notes

1. Please consult the most recently issued data sheet before initiating or completing a design.
2. The product status of the device(s) described in this data sheet may have changed since this data sheet was published. The latest information is available on the Internet at URL <http://www.semiconductors.philips.com>.

DEFINITIONS

Short-form specification — The data in a short-form specification is extracted from a full data sheet with the same type number and title. For detailed information see the relevant data sheet or data handbook.

Limiting values definition — Limiting values given are in accordance with the Absolute Maximum Rating System (IEC 60134). Stress above one or more of the limiting values may cause permanent damage to the device.

These are stress ratings only and operation of the device at these or at any other conditions above those given in the Characteristics sections of the specification is not implied. Exposure to limiting values for extended periods may affect device reliability.

Application information — Applications that are described herein for any of these products are for illustrative purposes only. Philips Semiconductors make no representation or warranty that such applications will be suitable for the specified use without further testing or modification.

DISCLAIMERS

Life support applications — These products are not designed for use in life support appliances, devices, or systems where malfunction of these products can reasonably be expected to result in personal injury. Philips Semiconductors customers using or selling these products for use in such applications do so at their own risk and agree to fully indemnify Philips Semiconductors for any damages resulting from such application.

Right to make changes — Philips Semiconductors reserves the right to make changes, without notice, in the products, including circuits, standard cells, and/or software, described or contained herein in order to improve design and/or performance. Philips Semiconductors assumes no responsibility or liability for the use of any of these products, conveys no licence or title under any patent, copyright, or mask work right to these products, and makes no representations or warranties that these products are free from patent, copyright, or mask work right infringement, unless otherwise specified.

Wideband code division multiple access
frequency division duplex power amplifier

UAA3592

NOTES

Philips Semiconductors – a worldwide company

Contact information

For additional information please visit <http://www.semiconductors.philips.com>. Fax: **+31 40 27 24825**

For sales offices addresses send e-mail to: sales.addresses@www.semiconductors.philips.com.

© Koninklijke Philips Electronics N.V. 2002

SCA74

All rights are reserved. Reproduction in whole or in part is prohibited without the prior written consent of the copyright owner.

The information presented in this document does not form part of any quotation or contract, is believed to be accurate and reliable and may be changed without notice. No liability will be accepted by the publisher for any consequence of its use. Publication thereof does not convey nor imply any license under patent- or other industrial or intellectual property rights.

Printed in The Netherlands

403506/01/pp12

Date of release: 2002 Jul 02

Document order number: 9397 750 09326

Let's make things better.

**Philips
Semiconductors**



PHILIPS