

## Dual Full-Bridge Motor Driver

### Features

- 750 mA Continuous Output Current
- Load Voltage Supply: 10V to 40V
- Full Bipolar Stepper Motor Drive Capability
- Bidirectional DC Motor Capability
- Internal Fixed T<sub>OFF</sub> Time PWM Current Control
- Internal Protection Diodes
- Internal Thermal Shutdown
- Under Voltage Lockout
- LS-TTL Compatible Logic Inputs with Pull-Up Resistors
- Low R<sub>ON</sub> Output Resistance
- Low Quiescent Current
- Operating Temperature Range: -20°C to +85°C
- Pin Compatible with Allegro 2916

### Applications

- Stepper Motor Actuators
- DC Motor Actuators
- Automotive HVAC Ventilation
- Automotive Power Seats

**Note:** The MTS2916A device is formerly a product of Advanced Silicon.

### Description

The MTS2916A motor driver is a CMOS device capable of driving both windings of a bipolar stepper motor or bidirectionally control two DC motors. Each of the two independent H-bridge outputs is capable of sustaining 40V and delivering up to 750 mA of continuous current. The output current level is controlled by an internal PWM circuit that is configured using two logic inputs, a current sense resistor and a selectable reference voltage. The H-bridge outputs have been optimized to provide a low output saturation voltage drop.

Full, half, and micro-stepping operations are possible with the PWM current control and logic inputs. The maximum output current is set by a sensing resistor and a user selectable reference voltage. The output current limit is selected using two logic level inputs. The selectable output current limits are 0%, 33%, 67%, or 100% of the maximum output current. Each bridge has a PHASE input signal which is used to control the direction of current flow through the H-bridge and the load.

The H-bridge power stage is controlled by non-overlapping signals which prevent current cross conduction when switching the direction of the current flow. Internal clamp diodes protect against inductive transients. Thermal protection circuitry disables the outputs when the junction temperature exceeds the safe operating limit. No special power-up sequencing is required. Undervoltage Lockout circuitry prevents the chip from operating when the load supply is applied prior to the logic supply.

The device is supplied in a 24-pin SOP package.

### Package Types

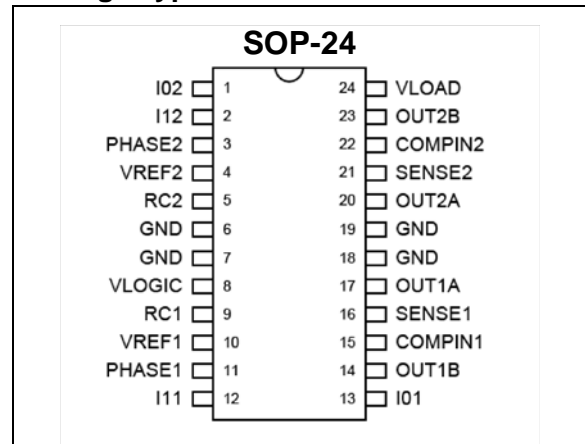

# MTS2916A

## Functional Block Diagram

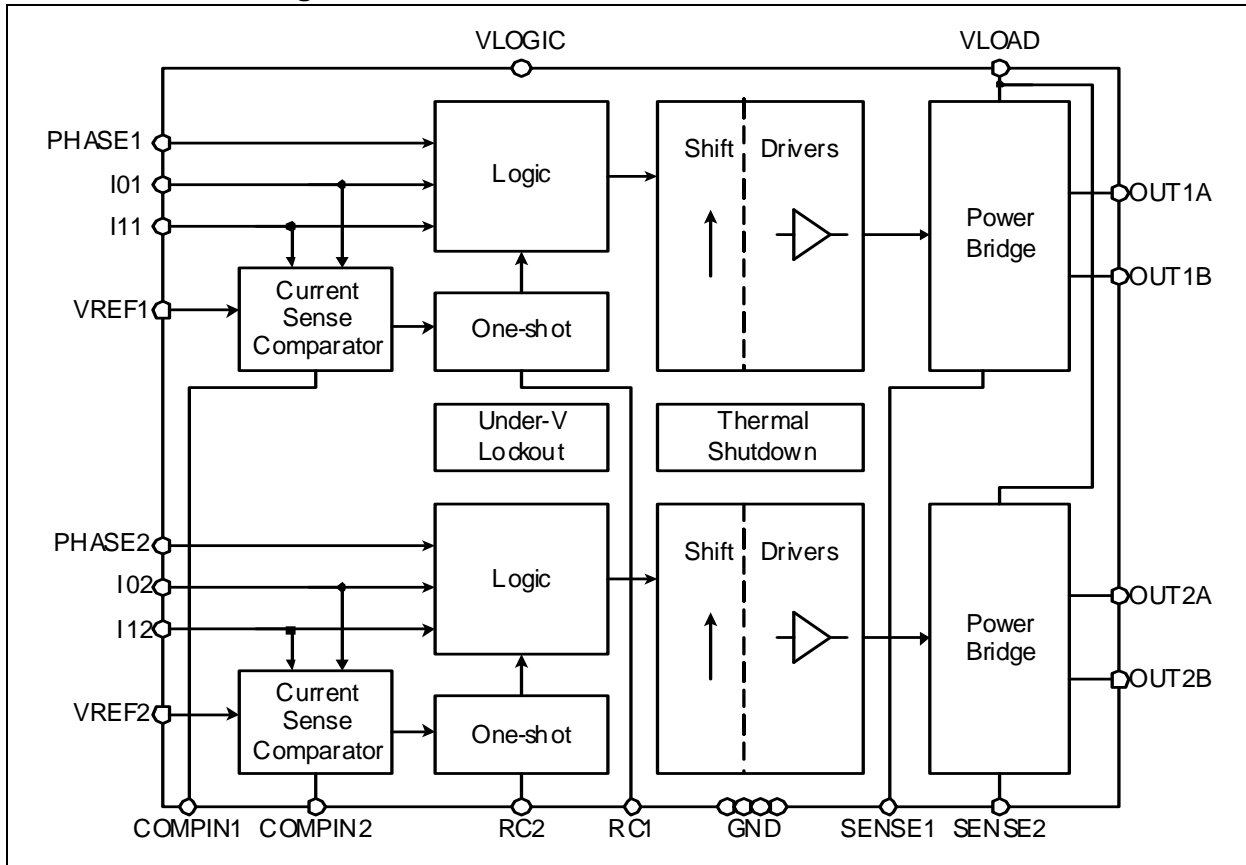

Typical Application

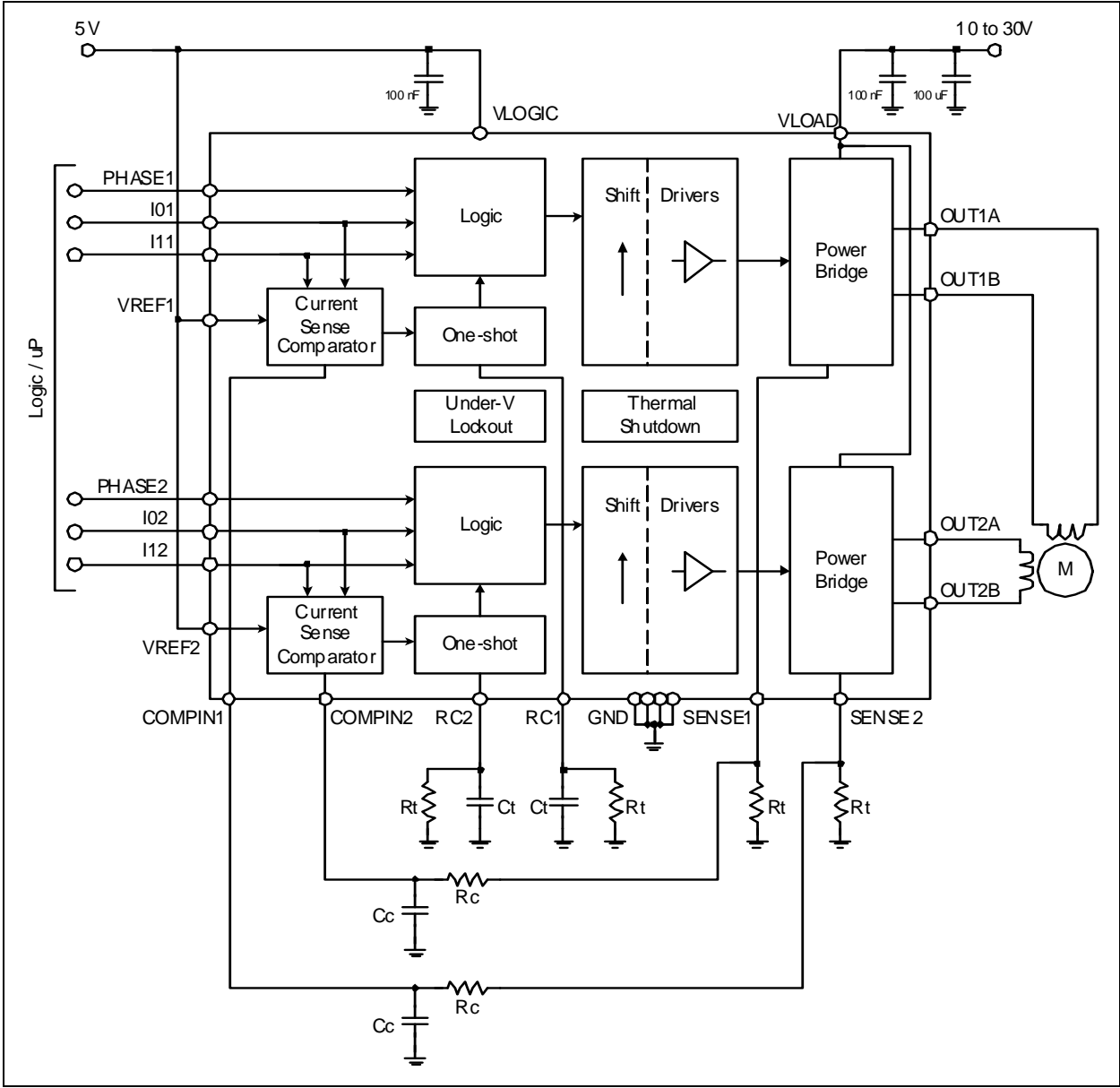

# MTS2916A

## 1.0 ELECTRICAL CHARACTERISTICS

### Absolute Maximum Ratings †

Logic Supply Voltage ( $V_{\text{LOGIC}}$ )	-0.3 to +5.5V
Load Supply Voltage ( $V_{\text{LOAD}}$ )	-0.3 to +40.0V
Logic Input Voltage Range ( $V_{\text{IN}}$ )	-0.3 to $V_{\text{LOGIC}} + 0.3\text{V}$
$V_{\text{REF}}$ Voltage Range ( $V_{\text{REF}}$ )	-0.3 to +10.0V
Output Current (Peak)	$\pm 1\text{A}$
Output Current (Continuous)	$\pm 0.75\text{A}$
Sense Output Voltage	-0.3V to 1.5V
Junction Temperature ( $T_{\text{J}}$ )	-20°C to +150°C
Operating Temperature Range ( $T_{\text{OPR}}$ )	-20°C to +85°C
Storage Temperature Range ( $T_{\text{STG}}$ )	-55°C to +150°C

† **Notice:** Stresses above those listed under “Maximum Ratings” may cause permanent damage to the device. This is a stress rating only and functional operation of the device at those or any other conditions above those indicated in the operational listings of this specification is not implied. Exposure to maximum rating conditions for extended periods may affect device reliability.

## ELECTRICAL CHARACTERISTICS

**Electrical Specifications:** Unless otherwise specified, all limits are established for  $V_{\text{LOGIC}} = 4.5\text{V}$  to  $5.5\text{V}$ ,  $V_{\text{LOAD}} = 30\text{V}$ ,  $V_{\text{REF}} = 5\text{V}$ ,  $T_{\text{A}} = 25^\circ\text{C}$

Parameters	Sym	Min	Typ	Max	Units	Conditions
<b>DC Characteristics</b>						
Logic Supply Voltage	$V_{\text{LOGIC}}$	4.5	5.0	5.5	V	
Load Supply Voltage	$V_{\text{LOAD}}$	10	30	40	V	
Logic Supply Current	$I_{\text{VLOGIC}}$	—	0.8	1.0	mA	
$V_{\text{REF}}$ Voltage Range	$V_{\text{REF}}$	1.5	5.0	7.0	V	
Driver Supply Current	$I_{\text{VLOAD\_ON}}$	—	0.55	1.0	mA	Both Bridges ON, No Load
	$I_{\text{VLOAD\_OFF}}$	—	0.55	1.0	mA	Both Bridges Off
Control Logic Input Current ( $V_{\text{IN}} = 0\text{V}$ )	$I_{\text{IN}}$	—	—	-70	$\mu\text{A}$	I01,I11,I02,I12,PHASE1,PHASE2, (Note 1)
Logic Low Input Voltage	$V_{\text{IL}}$	—	—	0.8	V	I01,I11,I02,I12,PHASE1,PHASE2
Logic High Input Voltage	$V_{\text{IH}}$	2.4	—	—	V	I01,I11,I02,I12,PHASE1,PHASE2
Current Limit Threshold Ratio ( $V_{\text{REF}} \div V_{\text{SENSE}}$ )	$V_{\text{REF\_VSENSE}}$	9.5	10	10.5	—	I0=L,I1=L
		13.5	15	16.5	—	I0=H,I1=L
		25.5	30	34.5	—	I0=L,I1=H
Driver Output Saturation Voltage $V_{\text{CE(SAT)}}$	$V_{\text{ONN}}$ (Low Side)	—	0.55	0.65	V	(Sink) IOU = +500 mA
		—	0.90	1.00	V	(Sink) IOU = +750 mA
	$V_{\text{ONP}}$ (High Side)	—	1.05	1.40	V	(Source) IOU = -500 mA
		—	1.85	2.10	V	(Source) IOU = -750 mA
Clamp Diode Forward Voltage (Note 2)	$V_{\text{F\_NDIODE}}$	—	0.95	1.30	V	$I_{\text{F}} = 750\text{ mA}$
	$V_{\text{F\_PDIODE}}$	—	1.00	1.30	V	$I_{\text{F}} = 750\text{ mA}$
Driver Output Leakage Current	$I_{\text{LEAK}}$	—	—	-50	$\mu\text{A}$	$V_{\text{OUT}} = 0\text{V}$
		—	—	50	$\mu\text{A}$	$V_{\text{OUT}} = V_{\text{LOAD}}$
Thermal Shutdown Temperature	$T_{\text{J\_SHDN}}$	—	170	—	$^\circ\text{C}$	
<b>AC Characteristics</b>						
Cut-off Time (one-shot pulse)	$T_{\text{OFF}}$	—	50	58	$\mu\text{s}$	$R_{\text{s}}=1\Omega, R_{\text{c}}=1\text{k}\Omega, C_{\text{c}}=820\text{pF}, R_{\text{t}}=56\text{k}\Omega, C_{\text{t}}=820\text{pF}$
Turn-off Delay	$T_{\text{D}}$	—	1.5	10	$\mu\text{s}$	
			—	—		

**Note 1:**  $V_{\text{IN}} = 5.0\text{V}$  input current given by internal pull-up to Logic Supply.

**2:** Clamp/Freewheel diode is the intrinsic body-drain diode of the NMOS and PMOS transistors.

## TEMPERATURE SPECIFICATIONS

Parameters	Sym	Min	Typ	Max	Units	Conditions
<b>Recommended Temperature Ranges</b>						
Junction Temperature Range	$T_J$	-20		+125	°C	
Operating Temperature Range	$T_A$	-20		+70	°C	
<b>Thermal Package Resistance</b>						
Thermal Resistance, SOP-24	$\theta_{JA}$ $\theta_{JC}$	— —	76 16	— —	°C/W	EIA/JEDEC JESD51-10

# MTS2916A

## 2.0 PIN DESCRIPTIONS

The descriptions of the pins are listed in [Table 2-1](#).

**TABLE 2-1: MTS2916A PIN FUNCTION TABLE**

Pin No. SOP-24	Type	Name	Function
1	Input	I02	Output 2 Current Selection Bit 0
2	Input	I12	Output 2 Current Selection Bit 1
3	Input	PHASE2	Output 2 Phase
4	Input	VREF2	Output 2 Current Reference
5	Input	RC2	Output 2 RC Time Constant
6	Power	GND	Negative Logic Supply (Ground)
7	Power	GND	Negative Logic Supply (Ground)
8	Power	VLOGIC	Positive Logic Supply Voltage
9	Input	RC1	Output 1 RC Time Constant
10	Input	VREF1	Output 1 Current Reference
11	Input	PHASE1	Output 1 Phase
12	Input	I11	Output 1 Current Selection Bit 1
13	Input	I01	Output 1 Current Selection Bit 0
14	Output	OUT1B	Output 1 'B' Side of Motor Winding
15	Input	COMPIN1	Current Sense Comparator Input for Output 1
16	Input	SENSE1	Current Sense for Output 1
17	Output	OUT1A	Output 1 'A' Side of Motor Winding
18	Power	GND	Negative Logic Supply (Ground)
19	Power	GND	Negative Logic Supply (Ground)
20	Output	OUT2A	Output 2 'A' Side of Motor Winding
21	Input	SENSE2	Current Sense for Output 2
22	Input	COMPIN2	Current Sense Comparator Input for Output 2
23	Output	OUT2B	Output 2 'B' Side of Motor Winding
24	Power	VLOAD	Positive Load Supply Voltage

### 2.1 Ground Terminal (GND)

Logic supply ground. Only the driver current flows out of this pin; there is no high current. Minimize voltage drops between this pin and the logic inputs.

### 2.2 Logic Supply Voltage (VLOGIC)

Connect VLOGIC to the logic source voltage. Decouple the supply with a 0.1  $\mu$ F ceramic capacitor mounted close to the VLOGIC and GND terminals.

### 2.3 Load Supply Voltage (VLOAD)

Connect VLOAD to the motor positive voltage supply. The motor current is supplied through this pin and the selected output transistors.

### 2.4 Current Detection Selection (I01, I02, I11, I12)

Comparator input for current threshold detection. The voltage across the sense resistor is fed back to this input through the low pass filter  $R_c C_c$ . The power transistors are disabled when the sense voltage exceeds the reference voltage of the selected comparator. When this occurs the current decays for a time set by  $R_t C_t$  ( $T_{OFF} = 1.1 R_t C_t$ ).

## 2.5 Current Flow Direction Selection (PHASE1, PHASE2)

Logic input to select the direction of current flow through the load. A "HIGH" logic signal level causes load current to flow from OUTxA to OUTxB. A "LOW" logic level causes load current to flow from OUTxB to OUTxA.

## 2.6 Current Sense Reference (VREF1, VREF2)

Reference voltage for current sense comparator. Determines the level of output current detection together with sensing resistor and inputs I0x, I1x.

## 2.7 Current Sense Input (SENSE1, SENSE2)

Connection to lower sources of output stage for insertion of current sense resistor.

## 2.8 Current Sense Comparator Input (COMPIN1, COMPIN2)

Current sense comparator input.

## 2.9 Output Stage OFF Time (RC1, RC2)

A parallel RtCt network connected to this pin sets the OFF time of the power transistors. The pulse generator is a monostable triggered by the output of the current sense comparator.

## 2.10 Output Stage (OUT1A, OUT2A, OUT1B, OUT2B)

Output connection to "A" side and "B" side of motor windings.

# MTS2916A

## 3.0 FUNCTIONAL DESCRIPTION

The circuit is designed to drive the two windings of a bipolar stepper motor and can be divided in two identical channels (channel 1 and channel 2) and protection circuitry for over temperature and undervoltage. The functionality of a channel and protection circuitry is presented on next sections.

## 3.1 Power Bridge Operation

Each motor winding is driven by an H-type bridge consisting of two N and two P transistors that allow the current to flow in both winding directions depending on the value of the PHASE signal (Table 3-1). The H-bridge can be set in 5 configurations that are related to the digital inputs PHASE, I0 and I1, and to the current sensed. These configurations are given in Table 3-2.

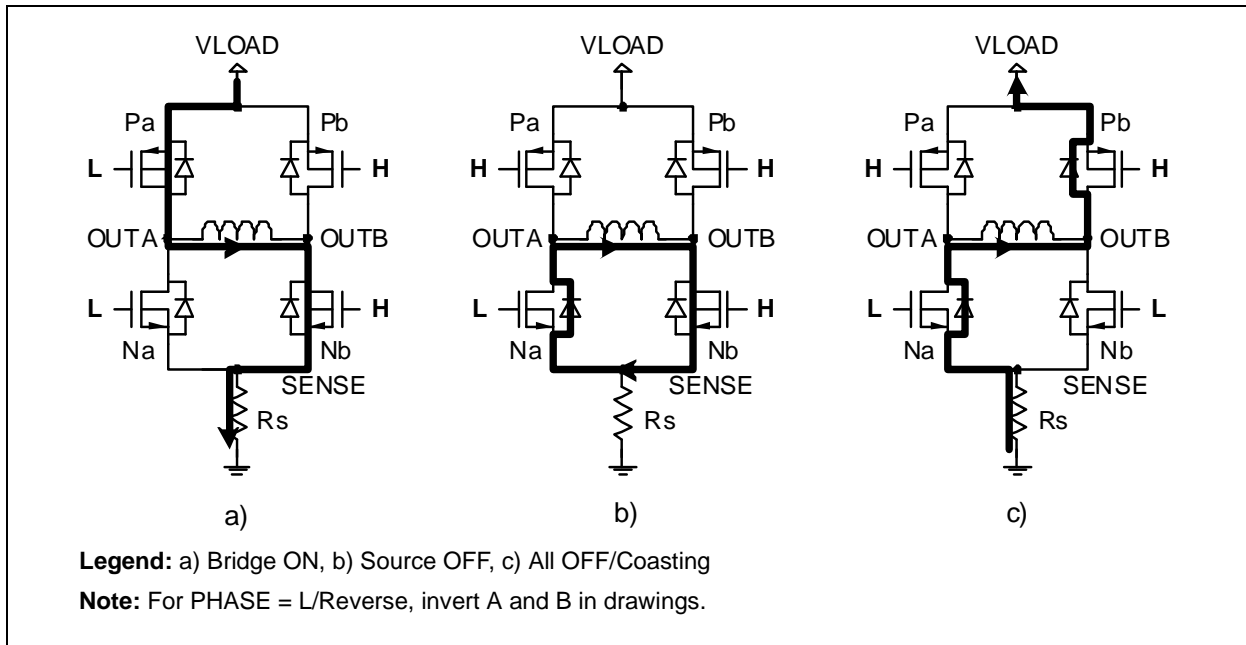

**FIGURE 3-1:** Power Bridge Control (PHASE = H/Forward)

**TABLE 3-1: CURRENT DIRECTION CONTROL**

PHASE	Output Current
L	Current flows from OUTxB to OUTxA
H	Current flows from OUTxA to OUTxB

**TABLE 3-2: POWER BRIDGE GATE CONTROL TRUTH TABLE**

I0I1	PHASE	overi	T <sub>OFF</sub>	Case/Mode	gna	gpa	gnb	gpb
00/01/10	1	0	0	Forward ON	L	<b>L</b>	<b>H</b>	H
00/01/10	1	x	1	Forward OFF	L	H	<b>H</b>	H
00/01/10	0	0	0	Reverse ON	<b>H</b>	H	L	<b>L</b>
00/01/10	0	x	1	Reverse OFF	<b>H</b>	H	L	H
11	x	x	x	No Current/Coasting	L	H	L	H

**Legend:** Bold = Active MOS Transistors, Overi = Overcurrent flag, T<sub>OFF</sub> = Channel T<sub>OFF</sub> State Flag



## 3.2 PWM Current Control

The current level in each motor winding is controlled by a PWM circuit with a fixed  $T_{OFF}$  time. The load current flowing in the winding is sensed through an external sensing resistor  $R_s$  connected between the power bridge's source pin SENSE (sources of transistors Na and Nb) and GND.

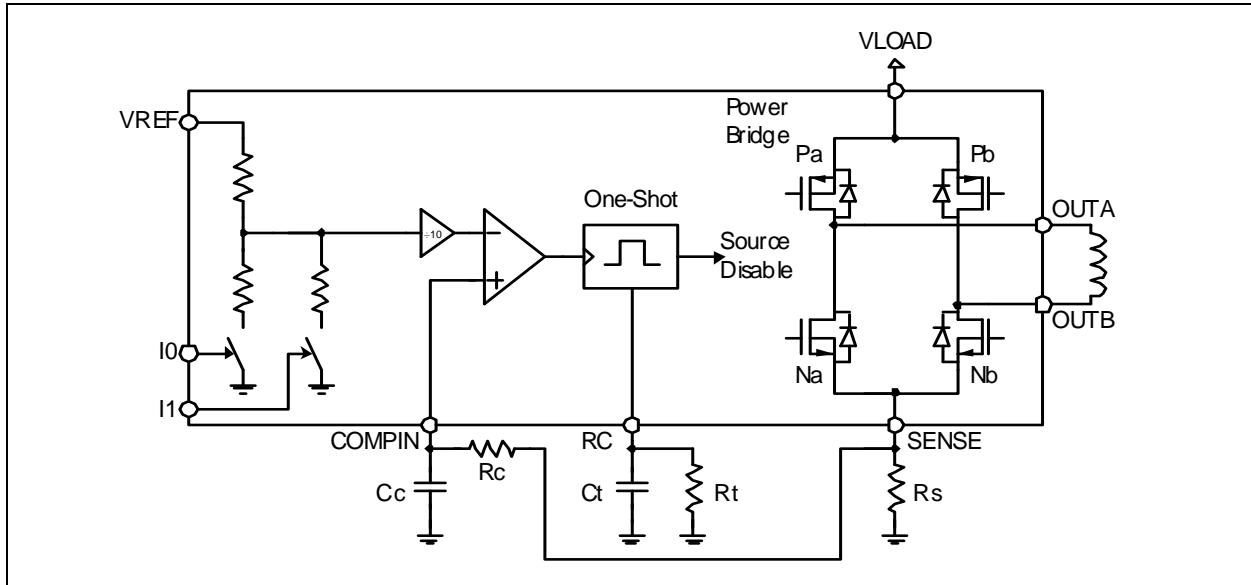

**FIGURE 3-2:** PWM Current Control Circuit Principle (Channel 1 Shown)

The voltage across  $R_s$  is compared to a fraction of the reference voltage  $V_{REF}$ , chosen with the logic input bits I0 and I1 (Table 3-3). The power bridge and thus the load current can also be switched off completely when both logic inputs are high. Note that any logic input left unconnected will be treated as a high level (pull-up resistor).

**EQUATION 3-1:**

$$I_{MAX} = \frac{V_{REF}}{10 * R_s}$$

The maximum trip current for regulation, given for I0 I1 = 00 is calculated in Equation 3-1.

**TABLE 3-3: CURRENT LEVEL CONTROL TRUTH TABLE**

I0	I1	Comp. Trip Voltage	Output Current
0	0	$V_{trip} = 1/10 * V_{ref}$	$I_{max} = V_{ref}/10RS$
1	0	$V_{trip} = 1/15 * V_{ref}$	$2/3 * I_{max} = V_{ref}/15RS$
0	1	$V_{trip} = 1/30 * V_{ref}$	$1/3 * I_{max} = V_{ref}/30RS$
1	1	x	0 (no current)

When the maximum allowed current is reached, the bridge source is turned off during a fixed period  $T_{OFF}$  (typically 50us) given by a non-retriggerable pulse generator and the external timing components  $R_t$  (20k-100 k $\Omega$  range) and  $C_t$  (100 pF-1000 pF range):

$$t_{off} = 1.1 * (R_t * C_t)$$

During  $T_{OFF}$ , the winding current decreases. When the driver is re-enabled, the winding current increases again until it reaches the threshold, and the cycle repeats itself maintaining the load current at the desired level.

# MTS2916A

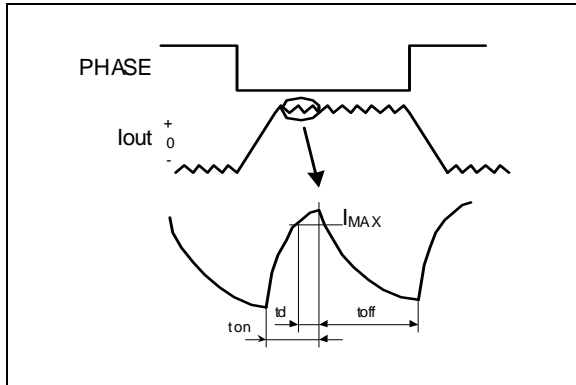

**FIGURE 3-3:** PWM Output Current Waveform

### 3.3 Circuit Protection

A thermal protection circuitry turns off all drivers when the junction temperature exceeds a safe operating limit of 170°C (typ.). This protects the devices from failure due to excessive heating. Despite this thermal protection, output short circuits are not permitted. The output drivers are re-enabled once junction temperature has dropped below 145°C (typ.).

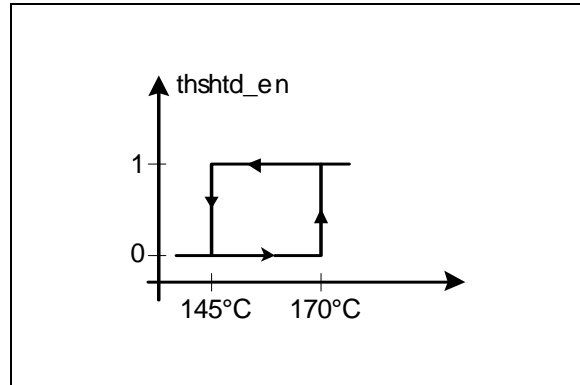

**FIGURE 3-4:** Thermal Shutdown Output vs. Temperature Showing Hysteresis

An undervoltage lockout circuit protects the MTS2916A from potential shoot-through currents when the load supply voltage is applied prior to the logic supply voltage. The power bridge and all outputs are disabled if VLOGIC is smaller than 4V.

With this protection feature, the circuit will withstand any order of turn-on or turn-off of the supply voltages VLOGIC and VLOAD. Normal dV/dt values are assumed.

## 4.0 APPLICATION CIRCUITS & ISSUES

### 4.1 Typical Application

The MTS2916A circuit with external components for a typical application is shown in Figure 4-1. Typical passive component values are:  $R_s = 1\Omega$ ,  $R_c = 1k\Omega$ ,  $C_c = 820pF$ ,  $R_t = 56k\Omega$  and  $C_t = 820pF$ .

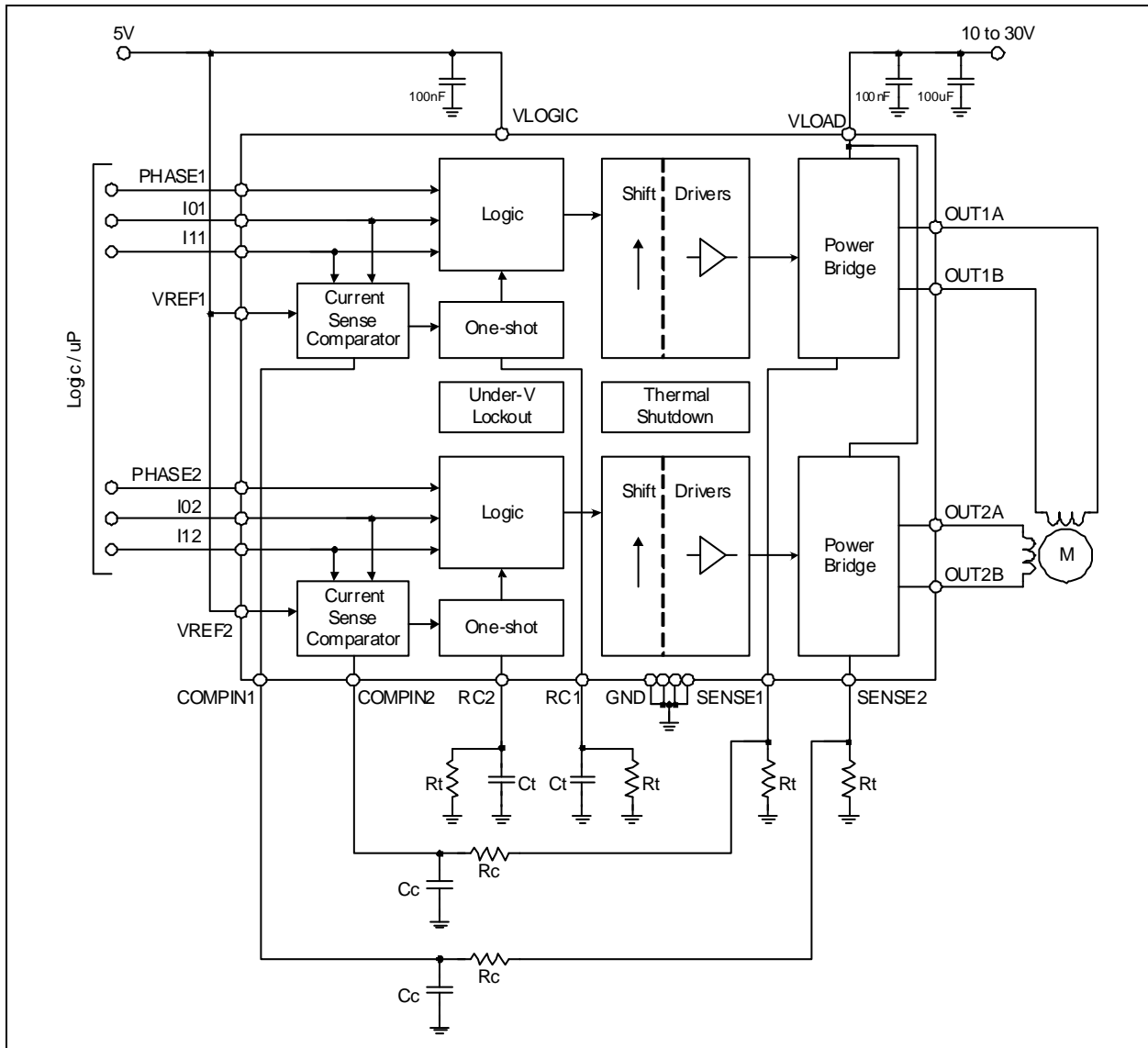

**FIGURE 4-1:** Typical Application Circuit

During PWM operation, when the output stage is turned-on, large voltage peaks might appear across  $R_s$ , which can wrongly trigger the input comparator. To avoid an unstable current control, an external  $R_c C_c$  filter should be used that delays the comparator action. Depending on load type, many applications will not require this filter (SENSE connected to COMPIN).

# MTS2916A

## 4.2 Stepping Examples

The MTS2916A allows to control a motor in full-step, half-step, modified half-step and microstepping mode, as shown in Figure 4-2.

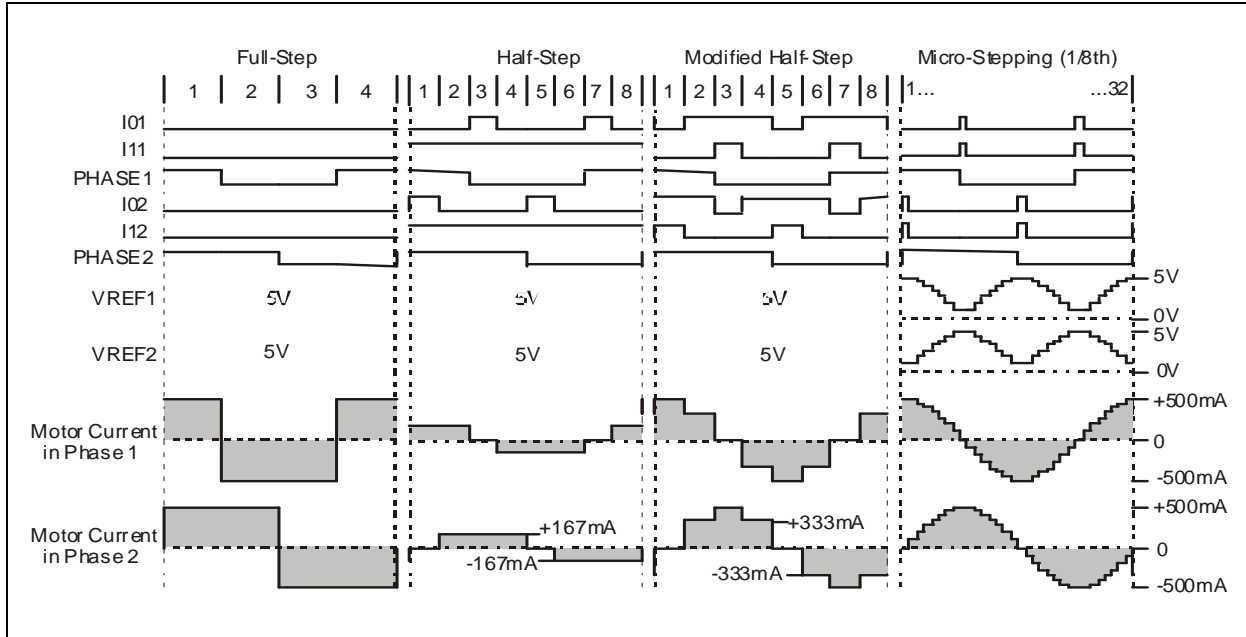

**FIGURE 4-2:** Examples of Stepping Modes Achievable with Typical Application Circuit

## 4.3 PCB Design Guidelines

Unused inputs should be connected to fixed voltage levels in order to get the highest noise immunity. Typical PCB layout guidelines for power application should be followed. These include separate power ground planes, supply decoupling capacitors close to the IC, short connections and use of maximized copper areas to improve thermal dissipation.

## 5.0 MECHANICAL DIMENSIONS

### SOP 24L Package Outline

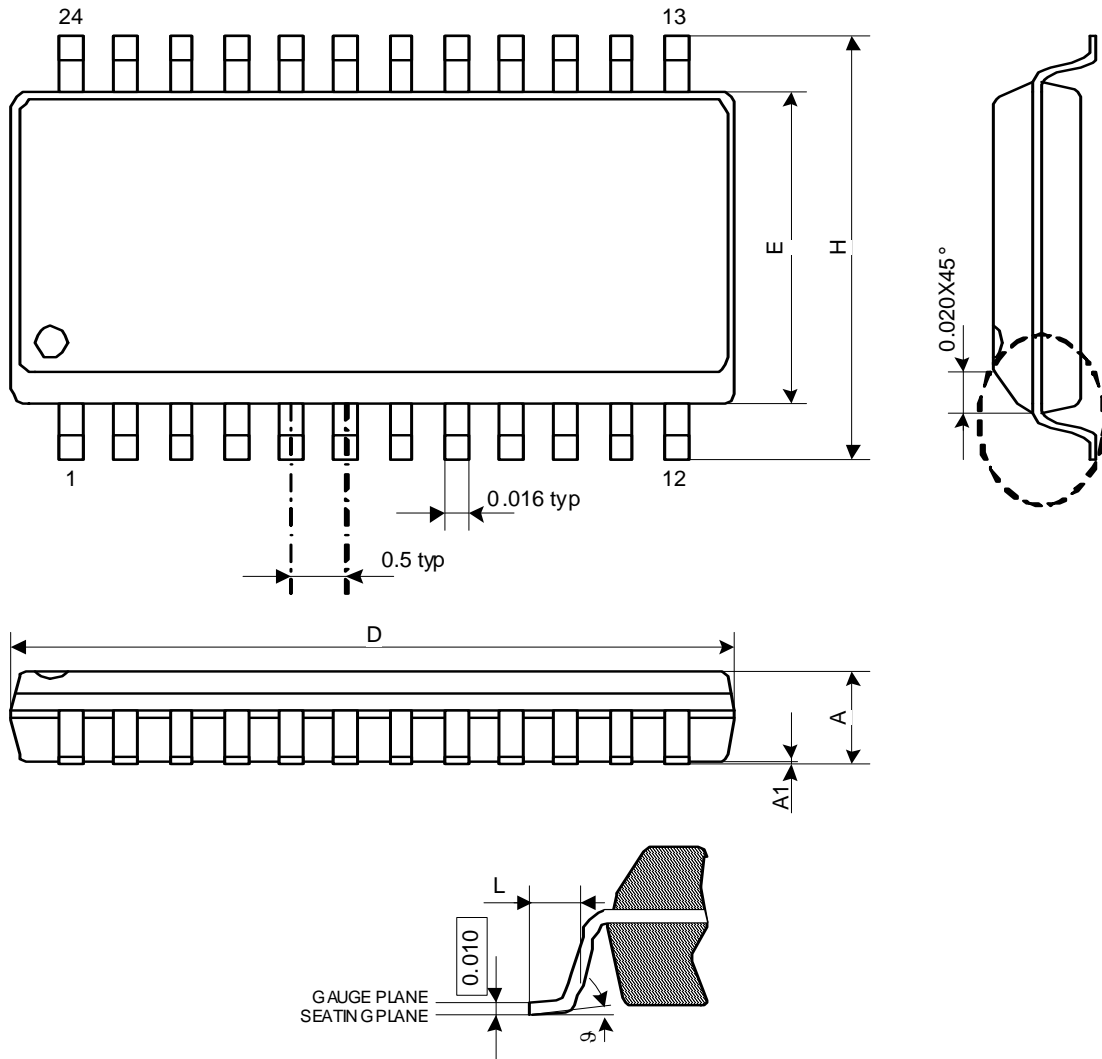

Symbol	Minimum	Typical	Maximum	Unit
A	—	—	2.642 (0.104)	mm (inch)
A1	0.102 (0.004)	—	—	mm (inch)
D	15.545 (0.612)	15.697 (0.618)	15.850 (0.624)	mm (inch)
E	7.417 (0.292)	7.518 (0.296)	7.595 (0.299)	mm (inch)
H	10.287 (0.405)	10.464 (0.412)	10.643 (0.419)	mm (inch)
L	0.533 (0.021)	0.787 (0.031)	1.041 (0.041)	mm (inch)
J	0	4	8	°

**Note 1:** JEDEC outline: M0-119 AA

- 2:** Dimensions "D" does not include mold flash, protrusions or gate burrs. Mold flash, protrusions and gate burrs should not exceed 0.25mm (0.010inch) per side.
- 3:** Dimensions "E" does not include inter-lead flash, or protrusions. Inter-lead flash and protrusions shall not exceed 0.25mm (0.010 inch) per side.

# MTS2916A

---

NOTES:

## APPENDIX A: REVISION HISTORY

### Revision A (September 2010)

- Original Release of this Document.

# MTS2916A

---

NOTES:



---

**Note the following details of the code protection feature on Microchip devices:**

- Microchip products meet the specification contained in their particular Microchip Data Sheet.
- Microchip believes that its family of products is one of the most secure families of its kind on the market today, when used in the intended manner and under normal conditions.
- There are dishonest and possibly illegal methods used to breach the code protection feature. All of these methods, to our knowledge, require using the Microchip products in a manner outside the operating specifications contained in Microchip's Data Sheets. Most likely, the person doing so is engaged in theft of intellectual property.
- Microchip is willing to work with the customer who is concerned about the integrity of their code.
- Neither Microchip nor any other semiconductor manufacturer can guarantee the security of their code. Code protection does not mean that we are guaranteeing the product as "unbreakable."

Code protection is constantly evolving. We at Microchip are committed to continuously improving the code protection features of our products. Attempts to break Microchip's code protection feature may be a violation of the Digital Millennium Copyright Act. If such acts allow unauthorized access to your software or other copyrighted work, you may have a right to sue for relief under that Act.

---

Information contained in this publication regarding device applications and the like is provided only for your convenience and may be superseded by updates. It is your responsibility to ensure that your application meets with your specifications. MICROCHIP MAKES NO REPRESENTATIONS OR WARRANTIES OF ANY KIND WHETHER EXPRESS OR IMPLIED, WRITTEN OR ORAL, STATUTORY OR OTHERWISE, RELATED TO THE INFORMATION, INCLUDING BUT NOT LIMITED TO ITS CONDITION, QUALITY, PERFORMANCE, MERCHANTABILITY OR FITNESS FOR PURPOSE. Microchip disclaims all liability arising from this information and its use. Use of Microchip devices in life support and/or safety applications is entirely at the buyer's risk, and the buyer agrees to defend, indemnify and hold harmless Microchip from any and all damages, claims, suits, or expenses resulting from such use. No licenses are conveyed, implicitly or otherwise, under any Microchip intellectual property rights.

**Trademarks**

The Microchip name and logo, the Microchip logo, dsPIC, KEELOQ, KEELOQ logo, MPLAB, PIC, PICmicro, PICSTART, PIC<sup>32</sup> logo, rPIC and UNI/O are registered trademarks of Microchip Technology Incorporated in the U.S.A. and other countries.

FilterLab, Hampshire, HI-TECH C, Linear Active Thermistor, MXDEV, MXLAB, SEEVAL and The Embedded Control Solutions Company are registered trademarks of Microchip Technology Incorporated in the U.S.A.

Analog-for-the-Digital Age, Application Maestro, CodeGuard, dsPICDEM, dsPICDEM.net, dsPICworks, dsSPEAK, ECAN, ECONOMONITOR, FanSense, HI-TIDE, In-Circuit Serial Programming, ICSP, Mindi, MiWi, MPASM, MPLAB Certified logo, MPLIB, MPLINK, mTouch, Omniscent Code Generation, PICC, PICC-18, PICDEM, PICDEM.net, PICkit, PICTail, REAL ICE, rLAB, Select Mode, Total Endurance, TSHARC, UniWinDriver, WiperLock and ZENA are trademarks of Microchip Technology Incorporated in the U.S.A. and other countries.

SQTP is a service mark of Microchip Technology Incorporated in the U.S.A.

All other trademarks mentioned herein are property of their respective companies.

© 2010, Microchip Technology Incorporated, Printed in the U.S.A., All Rights Reserved.

 Printed on recycled paper.

ISBN: 978-1-60932-536-7

*Microchip received ISO/TS-16949:2002 certification for its worldwide headquarters, design and wafer fabrication facilities in Chandler and Tempe, Arizona; Gresham, Oregon and design centers in California and India. The Company's quality system processes and procedures are for its PIC® MCUs and dsPIC® DSCs, KEELOQ® code hopping devices, Serial EEPROMs, microperipherals, nonvolatile memory and analog products. In addition, Microchip's quality system for the design and manufacture of development systems is ISO 9001:2000 certified.*

**QUALITY MANAGEMENT SYSTEM  
CERTIFIED BY DNV  
== ISO/TS 16949:2002 ==**



# MICROCHIP

## Worldwide Sales and Service

### AMERICAS

**Corporate Office**  
2355 West Chandler Blvd.  
Chandler, AZ 85224-6199  
Tel: 480-792-7200  
Fax: 480-792-7277  
Technical Support:  
<http://support.microchip.com>  
Web Address:  
[www.microchip.com](http://www.microchip.com)

**Atlanta**  
Duluth, GA  
Tel: 678-957-9614  
Fax: 678-957-1455

**Boston**  
Westborough, MA  
Tel: 774-760-0087  
Fax: 774-760-0088

**Chicago**  
Itasca, IL  
Tel: 630-285-0071  
Fax: 630-285-0075

**Cleveland**  
Independence, OH  
Tel: 216-447-0464  
Fax: 216-447-0643

**Dallas**  
Addison, TX  
Tel: 972-818-7423  
Fax: 972-818-2924

**Detroit**  
Farmington Hills, MI  
Tel: 248-538-2250  
Fax: 248-538-2260

**Kokomo**  
Kokomo, IN  
Tel: 765-864-8360  
Fax: 765-864-8387

**Los Angeles**  
Mission Viejo, CA  
Tel: 949-462-9523  
Fax: 949-462-9608

**Santa Clara**  
Santa Clara, CA  
Tel: 408-961-6444  
Fax: 408-961-6445

**Toronto**  
Mississauga, Ontario,  
Canada  
Tel: 905-673-0699  
Fax: 905-673-6509

### ASIA/PACIFIC

**Asia Pacific Office**  
Suites 3707-14, 37th Floor  
Tower 6, The Gateway  
Harbour City, Kowloon  
Hong Kong  
Tel: 852-2401-1200  
Fax: 852-2401-3431

**Australia - Sydney**  
Tel: 61-2-9868-6733  
Fax: 61-2-9868-6755

**China - Beijing**  
Tel: 86-10-8528-2100  
Fax: 86-10-8528-2104

**China - Chengdu**  
Tel: 86-28-8665-5511  
Fax: 86-28-8665-7889

**China - Chongqing**  
Tel: 86-23-8980-9588  
Fax: 86-23-8980-9500

**China - Hong Kong SAR**  
Tel: 852-2401-1200  
Fax: 852-2401-3431

**China - Nanjing**  
Tel: 86-25-8473-2460  
Fax: 86-25-8473-2470

**China - Qingdao**  
Tel: 86-532-8502-7355  
Fax: 86-532-8502-7205

**China - Shanghai**  
Tel: 86-21-5407-5533  
Fax: 86-21-5407-5066

**China - Shenyang**  
Tel: 86-24-2334-2829  
Fax: 86-24-2334-2393

**China - Shenzhen**  
Tel: 86-755-8203-2660  
Fax: 86-755-8203-1760

**China - Wuhan**  
Tel: 86-27-5980-5300  
Fax: 86-27-5980-5118

**China - Xian**  
Tel: 86-29-8833-7252  
Fax: 86-29-8833-7256

**China - Xiamen**  
Tel: 86-592-2388138  
Fax: 86-592-2388130

**China - Zhuhai**  
Tel: 86-756-3210040  
Fax: 86-756-3210049

### ASIA/PACIFIC

**India - Bangalore**  
Tel: 91-80-3090-4444  
Fax: 91-80-3090-4123

**India - New Delhi**  
Tel: 91-11-4160-8631  
Fax: 91-11-4160-8632

**India - Pune**  
Tel: 91-20-2566-1512  
Fax: 91-20-2566-1513

**Japan - Yokohama**  
Tel: 81-45-471- 6166  
Fax: 81-45-471-6122

**Korea - Daegu**  
Tel: 82-53-744-4301  
Fax: 82-53-744-4302

**Korea - Seoul**  
Tel: 82-2-554-7200  
Fax: 82-2-558-5932 or  
82-2-558-5934

**Malaysia - Kuala Lumpur**  
Tel: 60-3-6201-9857  
Fax: 60-3-6201-9859

**Malaysia - Penang**  
Tel: 60-4-227-8870  
Fax: 60-4-227-4068

**Philippines - Manila**  
Tel: 63-2-634-9065  
Fax: 63-2-634-9069

**Singapore**  
Tel: 65-6334-8870  
Fax: 65-6334-8850

**Taiwan - Hsin Chu**  
Tel: 886-3-6578-300  
Fax: 886-3-6578-370

**Taiwan - Kaohsiung**  
Tel: 886-7-213-7830  
Fax: 886-7-330-9305

**Taiwan - Taipei**  
Tel: 886-2-2500-6610  
Fax: 886-2-2508-0102

**Thailand - Bangkok**  
Tel: 66-2-694-1351  
Fax: 66-2-694-1350

### EUROPE

**Austria - Wels**  
Tel: 43-7242-2244-39  
Fax: 43-7242-2244-393

**Denmark - Copenhagen**  
Tel: 45-4450-2828  
Fax: 45-4485-2829

**France - Paris**  
Tel: 33-1-69-53-63-20  
Fax: 33-1-69-30-90-79

**Germany - Munich**  
Tel: 49-89-627-144-0  
Fax: 49-89-627-144-44

**Italy - Milan**  
Tel: 39-0331-742611  
Fax: 39-0331-466781

**Netherlands - Drunen**  
Tel: 31-416-690399  
Fax: 31-416-690340

**Spain - Madrid**  
Tel: 34-91-708-08-90  
Fax: 34-91-708-08-91

**UK - Wokingham**  
Tel: 44-118-921-5869  
Fax: 44-118-921-5820

08/04/10